

BAXI



Product information

High-efficiency wall-hung gas boiler

Quinta Ace S

50 - 60 - 70

Dear Customer,

Thank you very much for buying this appliance. Please read through the manual carefully before using the product, and keep it in a safe place for later reference. In order to ensure continued safe and efficient operation we recommend that the product is serviced regularly. Our service and customer service organisation can assist with this. We hope you enjoy years of problem-free operation with the product.

Contents

1	About this manual	4
1.1	Additional documentation	4
1.2	Symbols used in the manual	4
2	Description of the product	4
2.1	General description	4
2.2	Main components	5
2.3	Introduction to the BDR controls platform	6
2.4	Standard delivery	7
2.5	Accessories and options	7
3	Technical specifications	7
3.1	Homologations	7
3.1.1	Certifications	7
3.1.2	Gas categories	8
3.1.3	Directives	8
3.1.4	Factory test	8
3.2	Dimensions and connections	9
3.3	Electrical diagram	10
3.4	Technical data	11
3.5	Hydraulic resistance	13
4	Before installation	14
4.1	Installation regulations	14
4.2	Choice of the location	14
4.2.1	Location requirements	14
4.3	Requirements for the condensate drain	15
4.4	Requirements for water connections	15
4.4.1	Requirements for the central heating connections	15
4.5	Requirements for the gas connection	15
4.6	Requirements for the flue gas discharge system	16
4.6.1	Classification	16
4.6.2	Material	19
4.6.3	Dimensions of flue gas outlet pipe	19
4.6.4	Length of the flue and air supply pipes	20
4.6.5	Additional guidelines	22
4.7	Requirements for the electrical connections	22
4.8	Water quality and water treatment	23
5	Appendix	23
5.1	ErP information	23
5.1.1	Product fiche	23
5.1.2	Package sheet	24
5.2	EC Declaration of conformity	25

1 About this manual

1.1 Additional documentation

The following documentation is available in addition to this manual:

- Installation and user manual
- Cascade description
- Service manual
- Water quality instructions

1.2 Symbols used in the manual

This manual contains special instructions, marked with specific symbols. Please pay extra attention when these symbols are used.



Danger

Risk of dangerous situations that will result in death or serious injury.



Warning

Risk of dangerous situations that could result in death or serious injury.



Notice

Risk of dangerous situations that could result in damage to the product or other property.



Important

Please note: important information.

2 Description of the product

2.1 General description

The Quinta Ace S boilers are high-efficiency wall-hung gas boilers with the following properties:

- High-efficiency heating.
- Stainless steel heat exchanger.
- Limited emissions of polluting substances.
- Ideal choice for cascade configurations.

The following boiler types are available:

Tab.1 Boiler types

Name	Rated heat output (<i>Prated</i>)
Quinta Ace S 50	45 kW
Quinta Ace S 60	55 kW
Quinta Ace S 70	65 kW

2.2 Main components

Fig.1 General

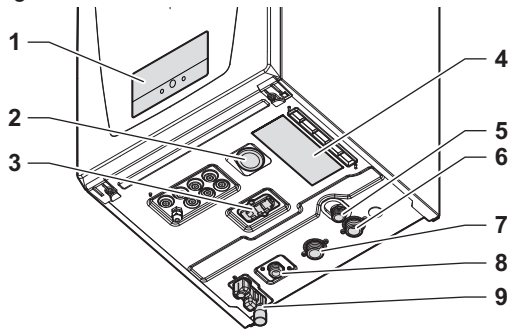

AD-3003369-01

- 1 Control panel
- 2 Pressure gauge
- 3 Quick connect
- 4 Data plate
- 5 Safety pressure relief valve outlet
- 6 Return pipe connection
- 7 Flow pipe connection
- 8 Gas pipe connection
- 9 Trap with condensate drain connection

Fig.2 Internal

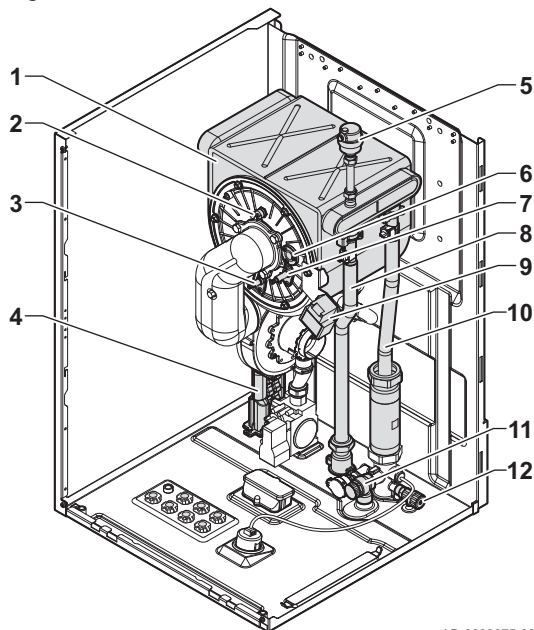

AD-3003075-02

- 1 Heat exchanger
- 2 Heat exchanger thermal switch
- 3 Ionisation electrode
- 4 Condensate trap
- 5 Automatic air valve
- 6 Flame inspection glass
- 7 Ignition electrode
- 8 Flow pipe
- 9 Ignition transformer
- 10 Return pipe
- 11 Safety pressure relief valve
- 12 Heat exchanger drain valve

Fig.3 Gas-air

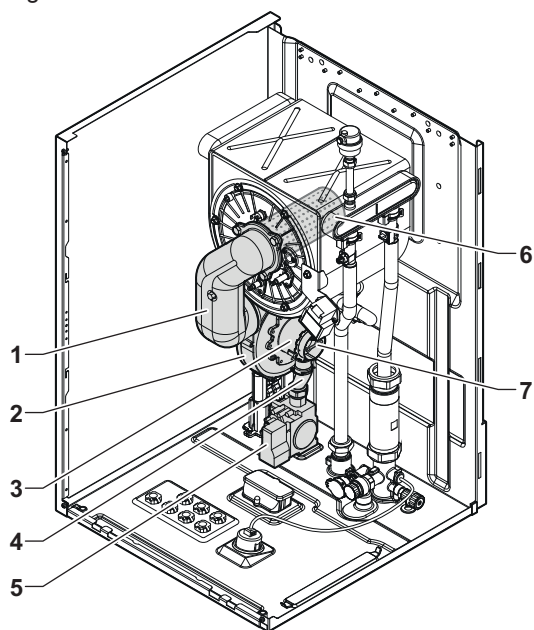

AD-3003076-01

- 1 Mixing tube
- 2 Fan
- 3 Venturi
- 4 Gas pipe
- 5 Gas control valve
- 6 Burner
- 7 Air inlet

Fig.4 Sensors and boxes

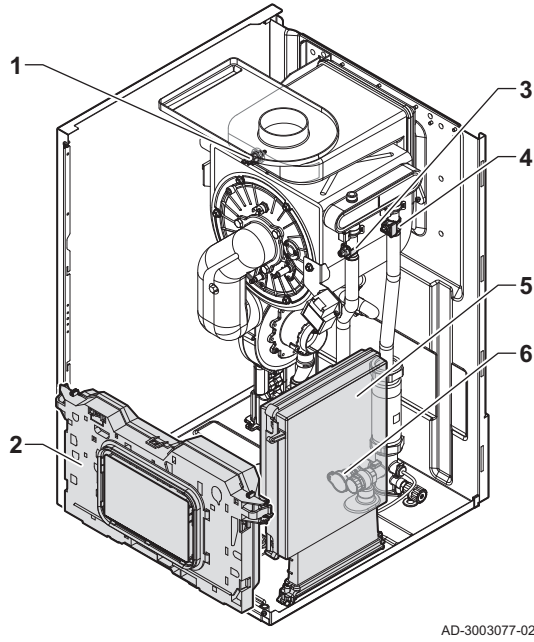

- 1 Flue gas temperature sensor
- 2 Control box
- 3 Flow temperature sensor
- 4 Return temperature sensor
- 5 Expansion box (optional)
- 6 Water pressure sensor

AD-3003077-02

2.3 Introduction to the BDR controls platform

The Quinta Ace S boiler is equipped with the BDR controls platform. This is a modular system, and offers compatibility and connectivity between all products that make use of the same platform.

Fig.5 Generic example

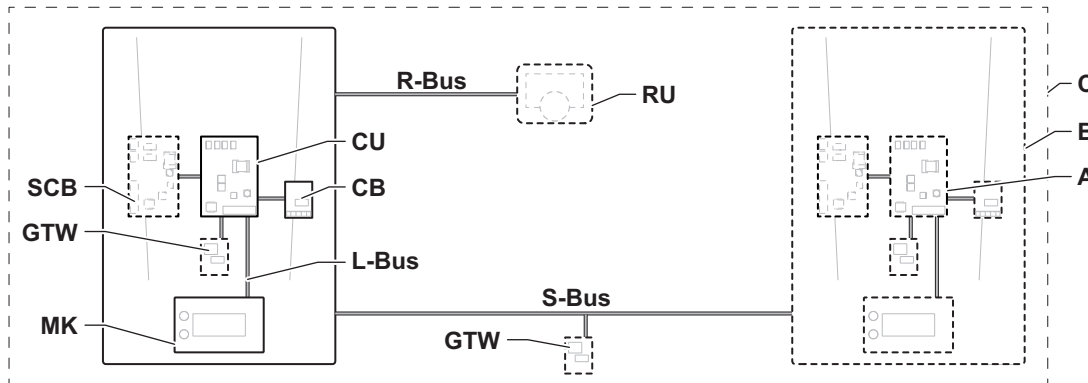

AD-3001366-02

Tab.2 Components in the example

Item	Description	Function
CU	Control Unit: Control unit	The control unit handles all basic functionality of the appliance.
CB	Connection Board: Connection PCB	The connection PCB provides easy access to all connectors of the control unit.
SCB	Smart Control Board: Expansion PCB	An expansion PCB provides extra functionality, like an internal calorifier or multiple zones.
GTW	Gateway: Conversion PCB	A gateway can be fitted to an appliance or system, to provide one of the following: <ul style="list-style-type: none"> • Extra (wireless) connectivity • Service connections • Communication with other platforms
MK	Control panel: Control panel and display	The control panel is the user interface to the appliance.
RU	Room Unit: Room unit (for example, a thermostat)	A room unit measures the temperature in a reference room.
L-bus	Local Bus: Connection between devices	The local bus provides communication between devices.
S-bus	System Bus: Connection between appliances	The system bus provides communication between appliances.
R-bus	Room unit Bus: Connection to a room unit	The room unit bus provides communication to a room unit.

Item	Description	Function
A	Device	A device is a PCB, control panel or a room unit.
B	Appliance	An appliance is a set of devices connected via the same L-bus
C	System	A system is a set of appliances connected via the same S-bus

Tab.3 Specific devices delivered with the Quinta Ace S boiler

Name visible in display	Software version	Description	Function
CU-GH20	0.2	Control unit CU-GH20	The CU-GH20 control unit handles all basic functionality of the Quinta Ace S boiler.
MK3	1.98	Control panel HMI Advanced	The HMI Advanced is the user interface to the Quinta Ace S boiler.

2.4 Standard delivery

Fig.6 Delivery

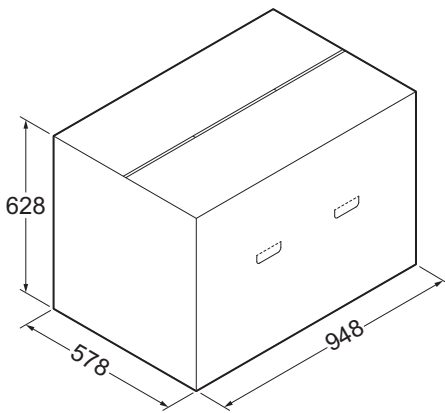

AD-3003028-02

The boiler is delivered in a packaging. The delivery includes:

- Quinta Ace S boiler
- Literature pack (including a mounting template)
- Wall mounting set

2.5 Accessories and options

Various accessories can be obtained for the boiler.



Important

Contact us for more information.

3 Technical specifications

3.1 Homologations

3.1.1 Certifications

Tab.4 Certifications

CE identification number	-
Class NOx ⁽¹⁾	6
Type of flue gas connection	B ₂₃ ⁽²⁾ C ₁₃ , C ₃₃ , C ₄₃ , C ₅₃ , C ₆₃ , C ₈₃ , C ₉₃
(1) EN 15502-1	
(2) When installing a boiler with connection type B ₂₃ , the IP rating of the boiler is lowered to IP20.	

3.1.2 Gas categories

Tab.5 Unit categories

Country	Category	Gas type	Connection pressure (mbar)
Great Britain	II _{2H3P}	G20 (H gas) G31 (propane)	20 37-50
Ireland	II _{2H3P}	G20 (H gas) G31 (propane)	20 37

3.1.3 Directives

In addition to the legal requirements and guidelines, the supplementary guidelines in this manual must also be followed.

Supplements or subsequent regulations and guidelines that are valid at the time of installation shall apply to all regulations and guidelines specified in this manual.

3.1.4 Factory test

Before leaving the factory, each boiler is optimally set and tested for:

- Electrical safety.
- Adjustment of O₂.
- Water tightness.
- Gas tightness.
- Parameter setting.

3.2 Dimensions and connections

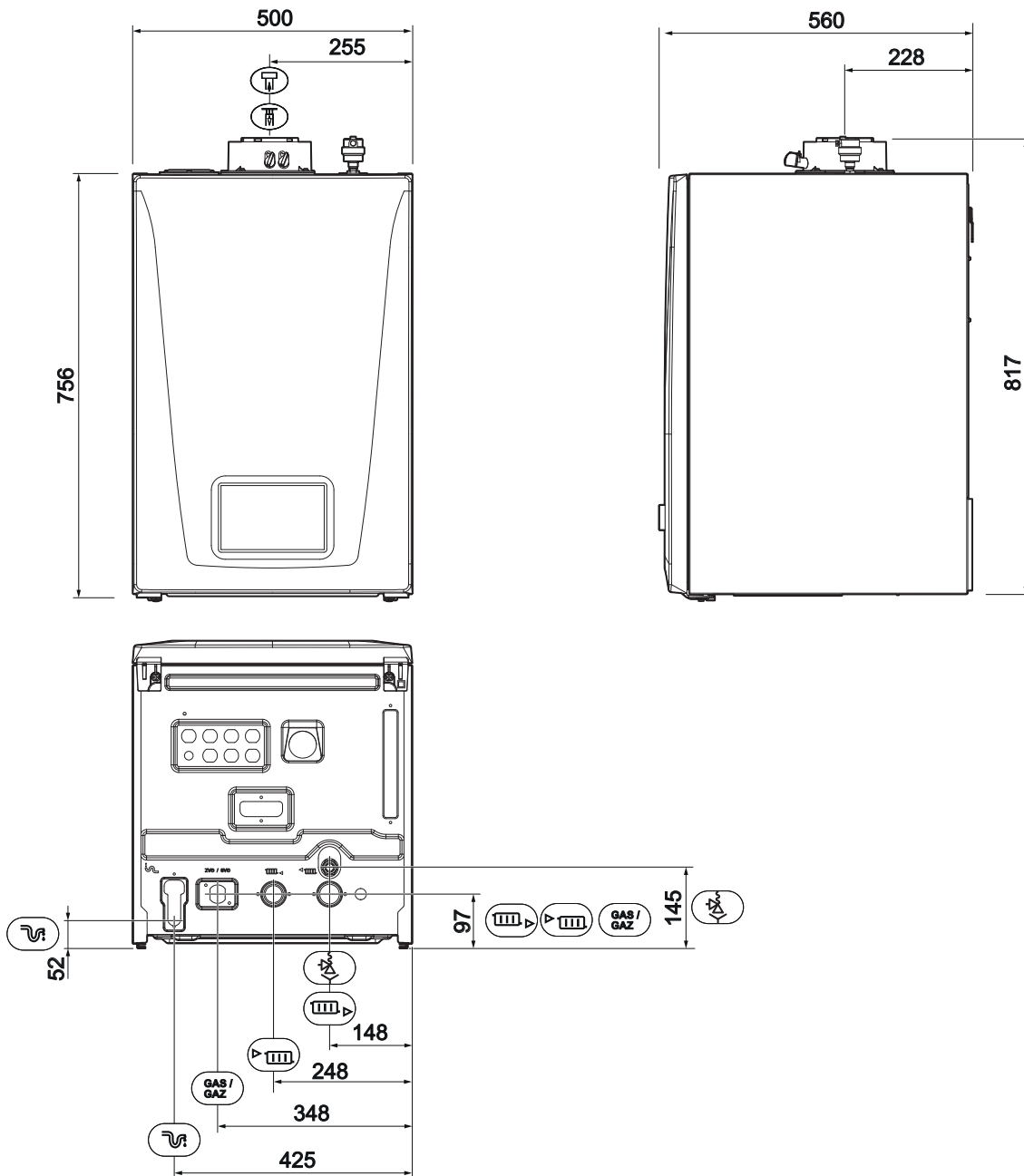

AD-3002659-04

Tab.6 Dimensions and connections

Symbol	Description	Dimension
	Flow connection	1" male thread
	Return connection	1" male thread
	Gas connection	3/4" male thread
	Condensation outlet	Ø 22 mm external
	Safety pressure relief valve outlet	3/4" male thread
	Flue gas outlet ⁽¹⁾	Ø 80 mm
	Air inlet ⁽²⁾	Ø 125 mm

(1) This is the inner pipe of the concentric flue gas adapter.
 (2) This is the outer pipe of the concentric flue gas adapter.

3.3 Electrical diagram

Fig.7 Electrical diagram for boiler types 50 - 60 - 70

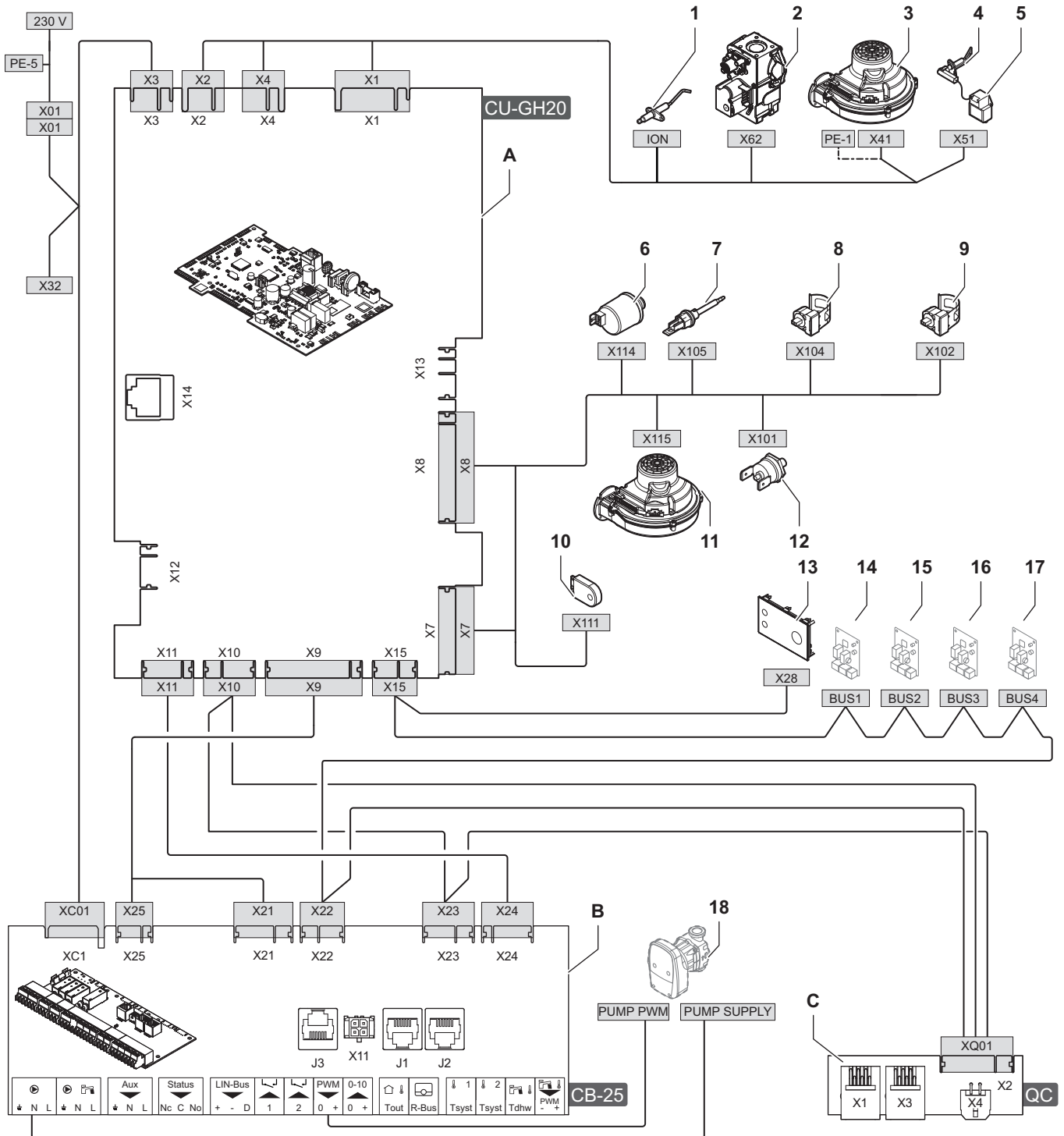

AD-3003111-01

- | | |
|--------------------------------------------------------------------------------------------------------------------------------------------------------------------------------------------------------------------------------------------------------------------------------------------------------------------------------------------------------------------------------------------------------------------------------------------------|---------------------------------------------------------------------------------------------------------------------------------------------------------------------------------------------------------------------------------------------------------------------------------------------------------------------------------------------------------------------------------------------------------------------------------------|
| <p>A Control unit - CU-GH20</p> <p>B Connection board - CB-25</p> <p>C Quick connection board - Quick connect</p> <p>1 Ionisation electrode</p> <p>2 Gas control valve</p> <p>3 Fan power supply</p> <p>4 Ignition electrode</p> <p>5 Ignition transformer</p> <p>6 Water pressure sensor</p> <p>7 Flue gas temperature sensor</p> <p>8 Flow temperature sensor</p> | <p>9 Return temperature sensor</p> <p>10 Configuration storage unit (CSU)</p> <p>11 PWM signal fan</p> <p>12 Thermal switch</p> <p>13 Control panel (HMI)</p> <p>14 CAN connection for expansion PCB</p> <p>15 CAN connection for expansion PCB</p> <p>16 CAN connection for expansion PCB</p> <p>17 CAN connection for expansion PCB</p> <p>18 Boiler pump</p> |
|--------------------------------------------------------------------------------------------------------------------------------------------------------------------------------------------------------------------------------------------------------------------------------------------------------------------------------------------------------------------------------------------------------------------------------------------------|---------------------------------------------------------------------------------------------------------------------------------------------------------------------------------------------------------------------------------------------------------------------------------------------------------------------------------------------------------------------------------------------------------------------------------------|

3.4 Technical data

Tab.7 General

Quinta Ace S				50	60	70
Nominal output	P_n 80/60 °C	kW	min max ⁽¹⁾	5.0 45.0	6.1 55.0	7.2 65.0
Nominal output	P_{nc} 50/30 °C	kW	min max ⁽¹⁾	5.4 48.6	6.6 59.4	7.8 70.2
Nominal input	Q_{nh} (H_i)	kW	min max ⁽¹⁾	5.1 46.3	6.3 56.6	7.4 66.9
Nominal input	Q_{nh} (H_s)	kW	min max ⁽¹⁾	5.7 51.4	7.0 62.8	8.2 74.3
Nominal input G31	Q_{nh} (H_i)	kW	min max ⁽¹⁾	5.1 46.3	6.3 56.6	7.4 66.9
Nominal input G31	Q_{nh} (H_s)	kW	min max ⁽¹⁾	5.7 51.4	7.0 62.8	8.2 74.3
Full load central heating efficiency	P_n (H_i) 80/60 °C	%		97.4	97.2	97.2
Full load central heating efficiency	H_i 50/30 °C	%		105.0	105.0	105.0
Part load central heating efficiency	P_n (H_i) RT=30 °C ⁽²⁾	%		107.8	107.5	107.1
Full load central heating efficiency	P_n (H_s) 80/60 °C	%		87.7	87.5	87.5
Full load central heating efficiency	H_s 50/30 °C	%		94.5	94.5	94.5
Part load central heating efficiency	P_n (H_s) RT=30 °C ⁽²⁾	%		97.1	96.8	96.4
(1)  Factory setting.						
(2) Return temperature.						

Tab.8 Details of gas and flue gas

Quinta Ace S				50	60	70
Gas test pressure	G20	mbar	min max	17 30	17 30	17 30
Gas test pressure	G31	mbar	min max	37 50	37 50	37 50
Gas consumption	G20	m ³ /h	min max	0.54 4.90	0.67 5.98	0.78 7.07
Gas consumption	G31	m ³ /h	min max	0.40 3.60	0.49 4.40	0.57 5.20
NOx annual emissions	G20 H_s (EN15502)	mg/kWh Class		53 6	28 6	32 6
CO annual emissions	G20 H_i (EN15502)	mg/kWh		14.1	18.7	23.7
NOx annual emission G20 (BREEAM EN15502)		mg/kWh Credits		17 2	19 2	22 2
Flue gas amount		kg/s	min max	0.002 0.021	0.003 0.026	0.004 0.031
Flue gas temperature		°C	max	92	96	76
Maximum counter pressure for flue gas outlet		Pa		185	175	192

Tab.9 Central heating circuit data



Quinta Ace S				50	60	70
Water content				4	5	6
Water operating pressure		bar	min	0.5	0.5	0.5
Water operating pressure (PMS)	<i>PMS</i>	bar	max	4	4	4
Water temperature		°C	max	80	80	80
Operating water temperature		°C	max	80	80	80

Quinta Ace S				50	60	70
Hydraulic resistance	$\Delta T=20$ K	mbar		470	520	455
Water flow	$\Delta T=11$ K	m ³ /h		3.52	4.30	5.08
Water flow at maximum CH input	80/60 °C	m ³ /h	nom	1.94	2.37	2.80
Water flow at minimum CH input	80/60 °C	m ³ /h	nom	0.22	0.26	0.31
Water flow at maximum CH input	50/30 °C	m ³ /h	nom	2.09	2.55	3.02
Water flow at minimum CH input	50/30 °C	m ³ /h	nom	0.23	0.28	0.34
Casing-related losses (without insulation)	$\Delta T=30$ °C	W		54	70	75

Tab.10 Electrical data

Quinta Ace S			50	60	70
Supply voltage		V~/Hz	230/50	230/50	230/50
Power consumption – full load ⁽¹⁾	max ⁽¹⁾	W	102	110	113
	min		21	19	19
Power consumption – standby ⁽¹⁾	P_{SB}	W	3	3	3
Electrical protection index		IP ⁽²⁾	X5D	X5D	X5D
Fuse – main (power connector)		(AT)	1.6	1.6	1.6
Fuse – CU-GH20		(AT)	2.5	2.5	2.5
Fuse – CB		(AT)	6.3	6.3	6.3
(1) Without pump.					
(2) When installing a boiler with connection type B ₂₃ , the IP rating of the boiler is lowered to IP20.					

Tab.11 Other data

Quinta Ace S			50	60	70
Total weight (including packaging)		kg	46.8	46.8	56.8
Total weight (netto)		kg	42.5	42.5	52.2
Minimum mounting weight ⁽¹⁾		kg	40.7	40.7	50.7
Average acoustic level ⁽²⁾ at a distance of 1 metre from the boiler (LpA)	 ⁽³⁾	dB(A)	62	59	62
Average sound power level (LwA)	 ⁽³⁾	dB(A)	54	51	54
(1) Without front panel.					
(2) Maximum.					
(3) Central heating operation.					

Tab.12 Technical parameters

Quinta Ace S			50	60	70
Condensing boiler			Yes	Yes	Yes
Low-temperature boiler ⁽¹⁾			No	No	No
B1 boiler			No	No	No
Cogeneration space heater			No	No	No
Combination heater			No	No	No
Rated heat output	P_{rated}	kW	45	55	65
Useful heat output at nominal heat output and high temperature operation ⁽²⁾	P_4	kW	45.0	55.0	65.0
Useful heat output at 30% of rated heat output and low temperature regime ⁽¹⁾	P_1	kW	14.9	18.2	21.5
Seasonal space heating energy efficiency	η_s	%	92	92	92
Useful efficiency at rated heat output and high temperature regime ⁽²⁾	η_4	%	87.8	87.6	87.6
Useful efficiency at 30% of rated heat output and low temperature regime ⁽¹⁾	η_1	%	97.1	96.9	96.5
Auxiliary electricity consumption					

Quinta Ace S			50	60	70
Full load	el_{max}	kW	0.102	0.110	0.113
Part load	el_{min}	kW	0.021	0.019	0.019
Standby mode	P_{SB}	kW	0.003	0.003	0.003
Other items					
Standby heat loss	P_{stby}	kW	0.064	0.070	0.075
Ignition burner power consumption	P_{ign}	kW	-	-	-
Annual energy consumption	Q_{HE}	GJ	141	172	203
Sound power level, indoors	L_{WA}	dB	62	59	62
Emissions of nitrogen oxides	NO_x	mg/kWh	29	31	31
(1) Low temperature means 30 °C for condensing boilers, 37 °C for low temperature boilers and 50 °C (at heater inlet) for other heating appliances.					
(2) High temperature operation means 60 °C return temperature at heater inlet and 80 °C feed temperature at heater outlet.					



See

The back cover for contact details.

3.5 Hydraulic resistance

Take the boiler resistance and system resistance into account when selecting a pump. The graph shows the hydraulic resistance at various water flow rates. The table shows some significant nominal flow data and the corresponding hydraulic resistance.

If possible, install the pump directly under the boiler on the return connection.



Important

When the pump is managed by the boiler's control unit, check if the deaeration program is correctly set (parameter **AP101 = 1**).

Fig.8 Hydraulic resistance

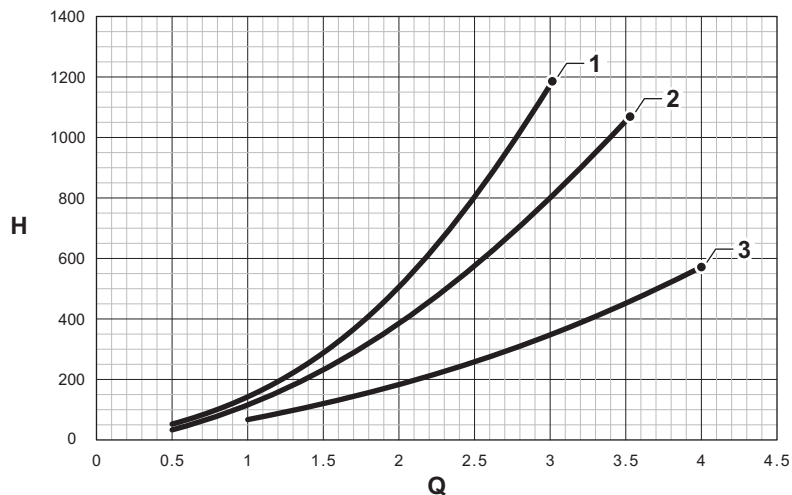

AD-3002745-01

Q Water flow (m³/h)
H Hydraulic resistance (mbar)
1 Quinta Ace S 50

2 Quinta Ace S 60
3 Quinta Ace S 70

Tab.13 Water flow rate data

	Unit	50	60	70
Minimum flow rate	m ³ /h	0.8	1.0	1.5
Maximum flow rate	m ³ /h	2.45	3.0	3.5
H at $\Delta T = 15\text{ °C}$	mbar	910	795	527
Q at $\Delta T = 15\text{ °C}$	m ³ /h	2.7	3.3	3.8
H at $\Delta T = 20\text{ °C}$	mbar	513	533	310
Q at $\Delta T = 20\text{ °C}$	m ³ /h	1.95	2.35	2.75

	Unit	50	60	70
H at $\Delta T = 30\text{ °C}$	mbar	218	262	167
Q at $\Delta T = 30\text{ °C}$	m ³ /h	1.3	1.6	1.9

4 Before installation

4.1 Installation regulations



Warning

The boiler must be installed by a qualified installer in accordance with local and national regulations.



Warning

The installer must be registered with Gas Safe and have the correct ACS qualifications.



Important

Practical guidelines - see the latest version.

4.2 Choice of the location

4.2.1 Location requirements



Danger

Never store combustible substances within 30 cm of the boiler, either temporarily or permanently.



Warning

- Fix the boiler to a solid wall capable of bearing the boiler when full of water and fully equipped.
- Do not place the boiler above a heat source or a cooking appliance.



Notice

The boiler must be installed in a frost-free area.



Important

- An earthed electrical connection must be available close to the boiler.
- A drain connection must be available close to the boiler.
- Do not locate the boiler in direct or indirect sunlight.

When choosing the best installation location, consider:

- The regulations.
- The required installation space.
- The permitted position of the flue gas outlet and/or air supply opening.
- The evenness of the surface.

When installing in a closed cupboard (or similar):

- Take the minimum distance between the boiler and the walls of the cupboard into account.
- Create ventilation openings with a minimum cross section: $S1 + S2 = 150\text{ cm}^2$

Fig.9 Location requirements

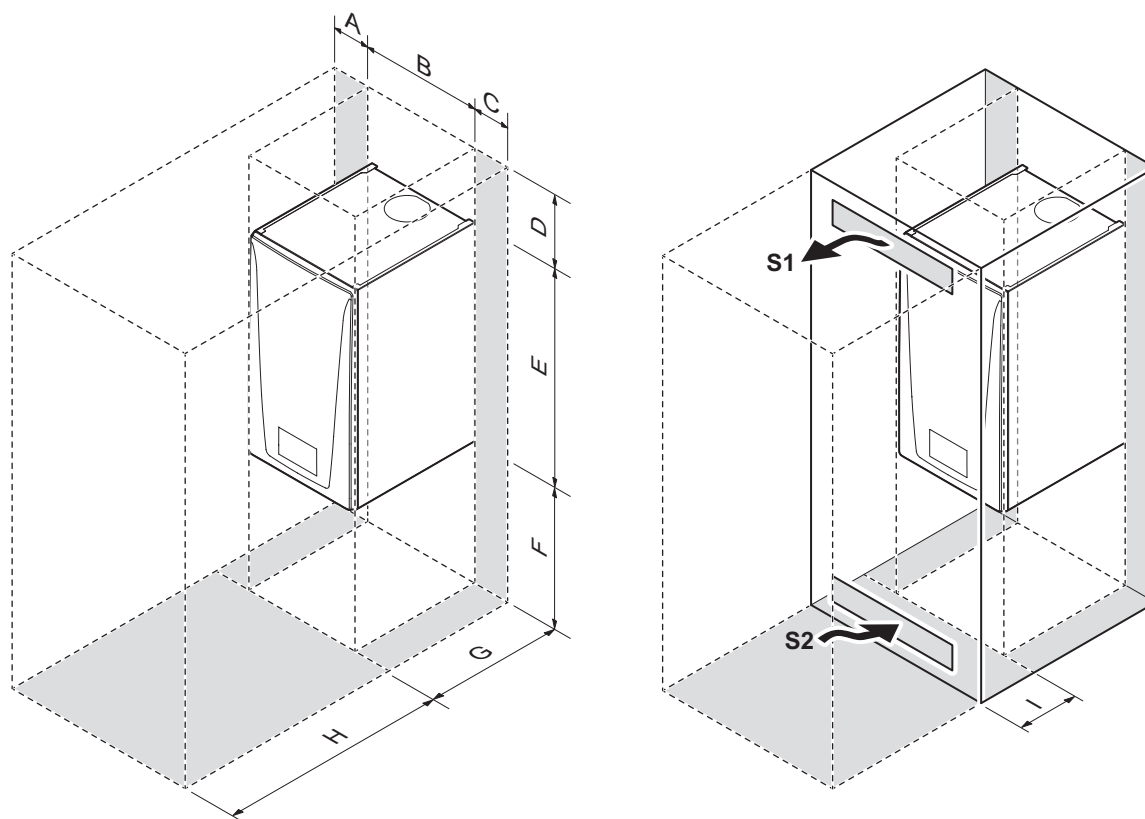

A ≥ 30 mm
B 500 mm
C ≥ 30 mm
D ≥ 430 mm
E 766 mm

F ≥ 500 mm
G 560 mm
H ≥ 1000 mm
I ≥ 240 mm

AD-3003137-02

4.3 Requirements for the condensate drain

- The drain pipe must be \varnothing 32 mm or larger, terminating in the drain.
- Use only plastic material for the discharge pipe due to the acidity (pH 2 to 5) of the condensate.
- Fit a trap in the drain pipe.
- The drain pipe must slope down at least 30 mm per metre, the maximum horizontal length is 5 metres.
- Do not make a fixed connection in order to prevent an overpressure in the trap.

4.4 Requirements for water connections

- Before installation, check that the connections meet the set requirements.
- Carry out any welding work required at a safe distance from the appliance.
- If using synthetic pipes, follow the manufacturer's instructions.

4.4.1 Requirements for the central heating connections

- We recommend installing a central heating filter in the return pipe to prevent clogging of boiler components.

4.5 Requirements for the gas connection

- Carry out any welding work required at a safe distance from the boiler.
- Before installing, check that the gas meter has sufficient capacity. Take into account the consumption of all appliances. Notify the local energy company if the gas meter has insufficient capacity.
- An installed boiler gas cock must always be accessible.
- We recommend installing a gas filter to prevent clogging of the gas control valve.

4.6 Requirements for the flue gas discharge system

4.6.1 Classification

Important

- The installer is responsible for choosing the correct type, diameter, and length of the flue system.
- Always use connection materials, roof terminal and/or horizontal flue terminal supplied by the same manufacturer. Consult the manufacturer for compatibility details.
- The use of flue systems from other manufacturers is allowed in addition to the recommended manufacturers listed in this manual. Use is only allowed when all our requirements are met and the description of flue system C₆₃ is respected.

Tab.14 Type of flue system: B₂₃

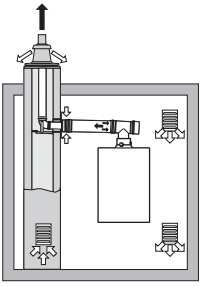
Principle	Description	Recommended manufacturers ⁽¹⁾
 <p>AD-3000924-01</p>	<p>Room-ventilated version.</p> <ul style="list-style-type: none"> • Without down-draught diverter. • Flue gas discharge via the roof. • Air supply from the installation area. • The air inlet connection of the boiler must stay open. • The installation area must be vented to ensure sufficient air supply. The vents must not be obstructed or shut off. • The IP rating of the boiler is lowered to IP20. 	<p>Connection material and roof terminal:</p> <ul style="list-style-type: none"> • Centrotherm • Cox Geelen • Muelink & Grol • Natalini
<p>(1) The material must also satisfy the material property requirements from the relevant chapter.</p>		

Tab.15 Type of flue system: C₁₃

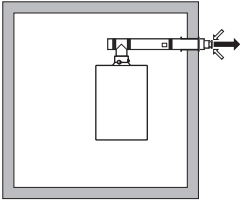
Principle	Description	Recommended manufacturers ⁽¹⁾
 <p>AD-3000926-01</p>	<p>Room-sealed version.</p> <ul style="list-style-type: none"> • Flue gas discharge in the outside wall. • The air inlet is in the same pressure zone as the flue (for example a horizontal flue terminal). • Parallel wall terminal not permitted. 	<p>Horizontal flue terminal and connection material:</p> <ul style="list-style-type: none"> • Cox Geelen • Muelink & Grol
<p>(1) The material must also satisfy the material property requirements from the relevant chapter.</p>		

Tab.16 Type of flue system: C₃₃

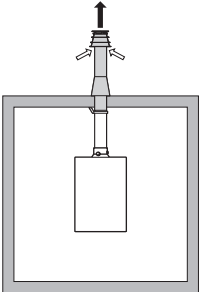
Principle	Description	Recommended manufacturers ⁽¹⁾
 <p>AD-3000927-01</p>	<p>Room-sealed version.</p> <ul style="list-style-type: none"> • Flue gas discharge via the roof. • The air inlet is in the same pressure zone as the flue (for example a concentric roof terminal). 	<p>Roof terminal and connection material</p> <ul style="list-style-type: none"> • Centrotherm • Cox Geelen • Muelink & Grol • Natalini
<p>(1) The material must also satisfy the material property requirements from the relevant chapter.</p>		

Tab.17 Type of flue system: C₄₃

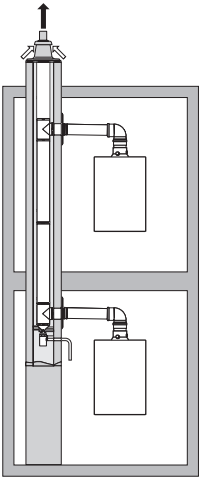
Principle ⁽¹⁾	Description	Recommended manufacturers ⁽²⁾
 <p>AD-3000928-01</p>	<p>Combined air inlet and flue system (common shared flue system) with overpressure.</p> <ul style="list-style-type: none"> • Concentric (preferably). • Parallel (if concentric is not possible). 	<p>Connecting material to the common shared flue system:</p> <ul style="list-style-type: none"> • Centrotherm • Cox Geelen • Muelink & Grol • Natalini
<p>(1) EN 15502-2-1: 0.5 mbar suction due to negative pressure. (2) The material must also satisfy the material property requirements from the relevant chapter.</p>		

Tab.18 Type of flue system: C₅₃

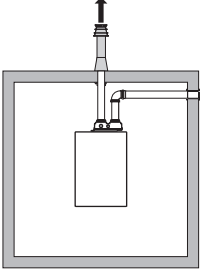
Principle	Description	Recommended manufacturers ⁽¹⁾
 <p>AD-3000929-02</p>	<p>Connection in different pressure zones.</p> <ul style="list-style-type: none"> • Closed unit. • Separate air inlet and flue. • Discharging into various pressure areas. • The air inlet and flue must not be placed on opposite walls. 	<p>Connection material and roof terminal:</p> <ul style="list-style-type: none"> • Centrotherm • Cox Geelen • Muelink & Grol • Natalini
<p>(1) The material must also satisfy the material property requirements from the relevant chapter.</p>		

Tab.19 Type of flue system: C₆₃

Principle	Description	Recommended manufacturers ⁽¹⁾
	<p>This system is supplied by us without an air inlet and flue. When selecting the material, please note the following:</p> <ul style="list-style-type: none"> • Condensed water must flow back to the boiler. • The material must be resistant to the flue gas temperature of this boiler. • Maximum permissible recirculation of 10%. • The air inlet and flue must not be placed on opposite walls. • Minimum permitted pressure difference between the air inlet and the flue is -200 Pa (including -100 Pa wind pressure). • A common shared flue system with overpressure is not permitted. 	<p>Use is only allowed when all our requirements are met and the description of this flue system type is respected.</p>
<p>(1) The material must also satisfy the material property requirements from the relevant chapter.</p>		

Tab.20 Type of flue system: C₈₃

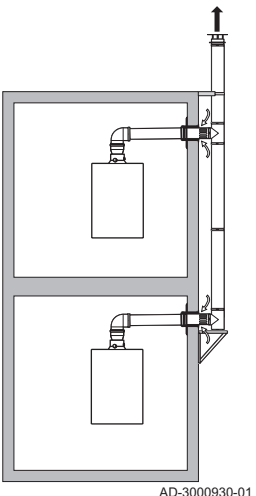
Principle ⁽¹⁾	Description	Recommended manufacturers ⁽²⁾
 <p style="text-align: center;">AD-3000930-01</p>	<p>Individual air inlet and shared flue system (common shared flue system).</p> <ul style="list-style-type: none"> Place a condensation drain, equipped with a trap, at the bottom of the duct. 	<p>Connecting material to the common shared flue system:</p> <ul style="list-style-type: none"> Centrotherm Cox Geelen Muelink & Grol Natalini
<p>(1) 4 mbar negative pressure can occur. (2) The material must also satisfy the material property requirements from the relevant chapter.</p>		

Tab.21 Type of flue system: C₉₃

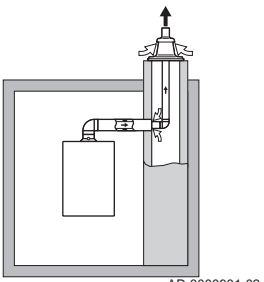
Principle ⁽¹⁾	Description	Recommended manufacturers ⁽²⁾
 <p style="text-align: center;">AD-3000931-02</p>	<p>Room-sealed version.</p> <ul style="list-style-type: none"> Air inlet and flue in shaft or duct: <ul style="list-style-type: none"> Concentric. Air supply from existing shaft or duct. Flue gas discharge via the roof. Air inlet is in the same pressure zone as the flue. 	<p>Connection material and roof terminal:</p> <ul style="list-style-type: none"> Centrotherm Cox Geelen Muelink & Grol Natalini
<p>(1) See table for shaft or duct requirements. (2) The material must also satisfy the material property requirements from the relevant chapter.</p>		

Tab.22 Minimum dimensions of shaft or duct C₉₃

Version (D)	Without air supply		With air supply	
Rigid 80 mm	Ø 130 mm	□ 130 x 130 mm	Ø 140 mm	□ 130 x 130 mm
Concentric 80/125 mm	Ø 145 mm	□ 145 x 145 mm	Ø 145 mm	□ 145 x 145 mm

Fig.10 Minimum dimensions of shaft or duct C₉₃

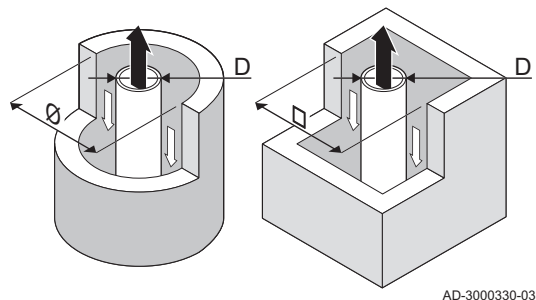

i Important
 The shaft must comply with the airtightness requirements of the local regulations.

i Important

- Always clean shafts thoroughly when using flue liners and/or an air inlet connection.
- It must be possible to inspect the flue liner.

4.6.2 Material

Use the string on the flue gas outlet material to check whether it is suitable for use on this appliance.

Fig.11 Sample string

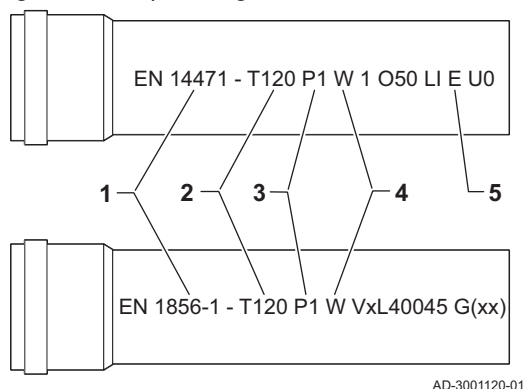

- 1 **EN 14471 or EN 1856-1**: The material is UKCA and CE approved according to this standard. For plastic this is EN 14471, For aluminium and stainless steel this is EN 1856-1.
- 2 **T120**: The material has temperature class T120. A higher number is also allowed, but not lower.
- 3 **P1**: The material falls into pressure class P1. H1 is also allowed.
- 4 **W**: The material is suitable for draining condensation water (W='wet'). D is not allowed (D='dry').
- 5 **E**: The material falls into fire resistance class E. Class A to D are also allowed, F is not allowed. Only applicable to plastic.



Warning

- The coupling and connection methods may vary depending on the manufacturer. It is not permitted to combine pipes, coupling and connection methods from different manufacturers. This also applies to roof terminal and common shared flue ducts.
- The materials used must comply with the prevailing regulations and standards.

Tab.23 Overview of material properties

Version	Flue gas outlet		Air supply	
	Material	Material properties	Material	Material properties
Single-wall, rigid	<ul style="list-style-type: none"> • Plastic⁽¹⁾ • Stainless steel⁽²⁾ • Thick-walled, aluminium⁽²⁾ 	<ul style="list-style-type: none"> • With UKCA and/or CE marking • Temperature class T120 or higher • Condensate class W (wet) • Pressure class P1 or H1 • Fire resistance class E or better⁽³⁾ 	<ul style="list-style-type: none"> • Plastic • Stainless steel • Aluminium 	<ul style="list-style-type: none"> • With UKCA and/or CE marking • Pressure class P1 or H1 • Fire resistance class E or better⁽³⁾
(1) according to EN 14471 (2) according to EN 1856 (3) according to EN 13501-1				

4.6.3 Dimensions of flue gas outlet pipe



Warning

The pipes connected to the flue gas adapter must satisfy the following dimension requirements.

Fig.12 Dimensions of open connection

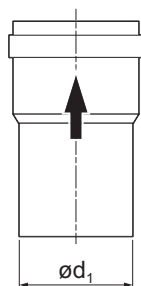

d_1 External dimensions of flue gas outlet pipe

Tab.24 Dimensions of pipe

	d_1 (min-max)
80 mm	79.3 - 80.3 mm

Fig.13 Dimensions of parallel connection

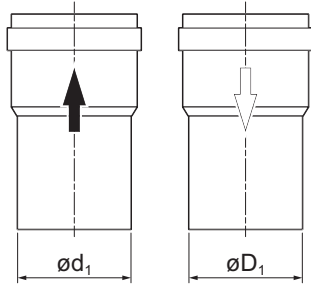

AD-3000963-01

d_1 External dimensions of flue gas outlet pipe
 D_1 External dimensions of air supply pipe

Tab.25 Dimensions of pipe

	d_1 (min-max)	D_1 (min-max)
80/80 mm	79.3 - 80.3 mm	79.3 - 80.3 mm

Fig.14 Dimensions of concentric connection

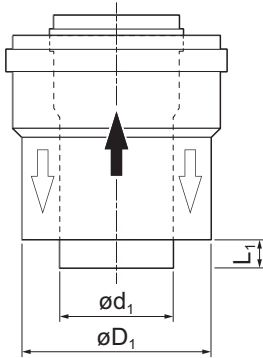

AD-3000962-01

d_1 External dimensions of flue gas outlet pipe
 D_1 External dimensions of air supply pipe
 L_1 Length difference between flue gas outlet pipe and air supply pipe

Tab.26 Dimensions of pipe

	d_1 (min-max)	D_1 (min-max)	$L_1^{(1)}$ (min-max)
80/125 mm	79.3 - 80.3 mm	124 - 125.5 mm	0 - 15 mm

(1) Shorten the inner pipe if the length difference is too great.

4.6.4 Length of the flue and air supply pipes

The maximum length of the flue and air supply vary per appliance type. Consult the relevant chapter for the correct lengths.

- If a boiler is not compatible with a specific flue system or diameter, it is indicated with "-" in the table.
- When using bends, the maximum flue length (L) must be shortened according to the reduction table.
- Use approved flue reducers for adaptation to another diameter.

■ Maximum flue lengths for C₁₃, C₃₃, C₆₃, C₉₃

Fig.15 Flue system length (Concentric)

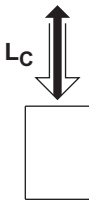

AD-3002011-01

L_C Length from the air inlet connection and flue gas connection up to the terminal.

Calculation: $L = L_C$

Tab.27 Maximum length (L)

Diameter ⁽¹⁾	80/125 mm
Quinta Ace S 50	20 m
Quinta Ace S 60	14 m
Quinta Ace S 70	10 m

(1) While maintaining the maximum length, additional 5 times 90° or 10 times 45° bends can be used (indicated for each boiler type and diameter).

Fig.16 Flue system length (Parallel)

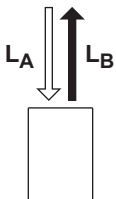

AD-3002010-01

L_A Length from the terminal up to the air inlet connection.

L_B Length from the flue gas connection up to the terminal.

Calculation: $L = L_A + L_B$

An 80/80 or 110/110 mm flue gas splitting kit (optional) must be fitted for this connection.

Tab.28 Maximum length (L)

Diameter ⁽¹⁾	80 – 80 mm ⁽²⁾
Quinta Ace S 50	32 m
Quinta Ace S 60	16 m
Quinta Ace S 70	10 m

(1) While maintaining the maximum length, additional 5 times 90° or 10 times 45° bends can be used (indicated for each boiler type and diameter).
(2) The maximum length was calculated with a concentric 80/125 mm terminal (indicated for each boiler type and diameter).

■ Maximum flue lengths for B₂₃

L_B Length from the flue gas connection up to the terminal.

$$\text{Calculation: } L = L_B$$

Tab.29 Maximum length (L)

Diameter ⁽¹⁾	80 mm
Quinta Ace S 50	38 m
Quinta Ace S 60	23 m
Quinta Ace S 70	18 m

(1) While maintaining the maximum length, additional 5 times 90° or 10 times 45° bends can be used (indicated for each boiler type and diameter).

■ Maximum flue lengths for C₅₃

L_A Length from the terminal up to the air inlet connection.

L_B Length from the flue gas connection up to the terminal.

$$\text{Calculation: } L = L_A + L_B$$



Important

The maximum permitted height difference between the air inlet and the roof terminal is 36 m.

Fig.17 Flue system length

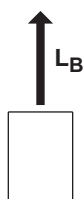

AD-3002009-01

Fig.18 Flue system length

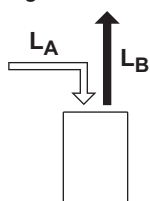

AD-3002013-01

Tab.30 Maximum length (L)

Diameter ⁽¹⁾	80 – 80 mm
Quinta Ace S 50	30 m
Quinta Ace S 60	18 m
Quinta Ace S 70	13 m

(1) While maintaining the maximum length, additional 5 times 90° or 10 times 45° bends can be used (indicated for each boiler type and diameter).

■ Reduction table

Tab.31 Pipe reduction for each bend - radius 1/2D (parallel)

Diameter	80 mm
	1.2 m
	4.0 m

Tab.32 Pipe reduction for each bend - radius $\frac{1}{2}D$ (concentric)

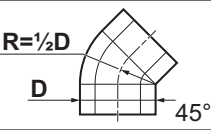
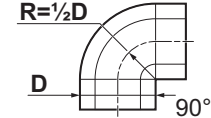
Diameter	80/125 mm
	1.0 m
	2.0 m

4.6.5 Additional guidelines

■ Installation



Warning

If the flue gas outlet and air supply materials are not installed in accordance with the instructions, this can result in dangerous situations and/or physical injury.

- For installing the flue gas outlet and air supply materials, refer to the instructions of the manufacturer of the material. After installation, check at least all flue gas outlet and air supply parts for tightness.
- Install the flue gas outlet pipe towards the boiler with a sufficient gradient (at least 50 mm per metre).
- Install a sufficient condensate collector and discharge at least 1 m before the outlet of the boiler.
- The bends used must be larger than 90° to guarantee the gradient and a good seal on the lip rings.

■ Condensation

- Direct connection of the flue gas outlet to structural ducts is not permitted because of condensation.
- If condensate from a plastic or stainless steel pipe section can flow back to an aluminium part in the flue gas outlet, this condensate must be discharged via a trap before it reaches the aluminium.
- Newly installed aluminium flue gas pipes with longer lengths can produce relatively larger quantities of corrosion products. Also casting sand and processing metal chips from new boilers can fill the boiler trap on short term after installation. Check and clean the trap more often for these reasons.

4.7 Requirements for the electrical connections

- Establish the electrical connections in accordance with all current local and national regulations and standards.
- Electrical connections must only be made by qualified installers, and only while the power supply is disconnected.
- The appliance is completely pre-wired. Never change the internal connections of the control panel.
- Always connect the appliance to a well-earthed installation.
- If the power cord is permanently connected, you must always install a main bipolar switch with an opening gap of at least 3 mm (BS EN 60335-1).
- The wiring must comply with the instructions in the electrical diagrams.
- Follow the recommendations in this manual.
- Separate the sensor cables from the 230 V cables

Make sure the following requirements are met when connecting the cables to the PCB connectors:

Tab.33 PCB connectors

Wire cross section	Stripping length	Tightening torque
solid wire: 0.14 – 4.0 mm ² (AWG 26 – 12)	8 mm	0.5 N·m
stranded wire: 0.14 – 2.5 mm ² (AWG 26 – 14)		
stranded wire with ferrule: 0.25 – 2.5 mm ² (AWG 24 – 14)		

4.8 Water quality and water treatment

The quality of the heating water must comply with the limit values in our **Water quality instructions**. The guidelines in these instructions must be followed at all times. In many cases, the boiler and central heating system can be filled with normal tap water and water treatment will not be necessary. You can go to the website for the instruction.

5 Appendix

5.1 ErP information

5.1.1 Product fiche

Tab.34 Product fiche

BAXI – Quinta Ace S		50	60	70
Seasonal space heating energy efficiency class		A	A	A
Rated heat output (<i>Prated</i>)	kW	45	55	65
Annual energy consumption(Q _{HE})	GJ	141	172	203
Seasonal space heating energy efficiency (η_s)	%	92	92	92
Sound power level L _{WA} indoors	dB(A)	62	59	62

5.1.2 Package sheet

Fig.19 Package sheet for boilers indicating the space heating energy efficiency of the package

Seasonal space heating energy efficiency of boiler ①
'I' %

Temperature control
 from fiche of temperature control

Class I = 1%, Class II = 2%, Class III = 1.5%,
 Class IV = 2%, Class V = 3%, Class VI = 4%,
 Class VII = 3.5%, Class VIII = 5%

②
 + %

Supplementary boiler
 from fiche of boiler

Seasonal space heating energy efficiency (in %)

③
 $(\text{ } - 'I') \times 0.1 = \pm \text{ } \%$

Solar contribution
 from fiche of solar device

Collector size (in m²)

Tank volume (in m³)

Collector efficiency (in %)

Tank rating ⁽¹⁾
 A* = 0.95, A = 0.91,
 B = 0.86, C = 0.83,
 D - G = 0.81

$$('III' \times \text{ } + 'IV' \times \text{ }) \times 0.9 \times (\text{ } / 100) \times \text{ } = + \text{ } \% \quad \text{④}$$

(1) If tank rating is above A, use 0.95

Supplementary heat pump
 from fiche of heat pump

Seasonal space heating energy efficiency (in %)

⑤
 $(\text{ } - 'I') \times 'II' = + \text{ } \%$

Solar contribution AND Supplementary heat pump
 select smaller value

$$0.5 \times \text{ } \text{ OR } 0.5 \times \text{ } = - \text{ } \% \quad \text{⑥}$$

Seasonal space heating energy efficiency of package ⑦
 %

Seasonal space heating energy efficiency class of package

<input type="checkbox"/>	<input type="checkbox"/>	<input type="checkbox"/>	<input type="checkbox"/>	<input type="checkbox"/>	<input type="checkbox"/>	<input type="checkbox"/>	<input type="checkbox"/>	<input type="checkbox"/>	<input type="checkbox"/>
G	F	E	D	C	B	A	A⁺	A⁺⁺	A⁺⁺⁺
<30%	≥30%	≥34%	≥36%	≥75%	≥82%	≥90%	≥98%	≥125%	≥150%

Boiler and supplementary heat pump installed with low temperature heat emitters at 35°C ?
 from fiche of heat pump

⑦
 $\text{ } + (50 \times 'II') = \text{ } \%$

The energy efficiency of the package of products provided for in this fiche may not correspond to its actual energy efficiency once installed in a building, as this efficiency is influenced by further factors such as heat loss in the distribution system and the dimensioning of the products in relation to building size and characteristics.

- I The value of the seasonal space heating energy efficiency of the preferential space heater, expressed in %.
- II The factor for weighting the heat output of preferential and supplementary heaters of a package as set out in the following table.
- III The value of the mathematical expression: $294/(11 \cdot \text{Prated})$, whereby 'Prated' is related to the preferential space heater.
- IV The value of the mathematical expression $115/(11 \cdot \text{Prated})$, whereby 'Prated' is related to the preferential space heater.

Tab.35 Weighting of boilers

$P_{sup} / (Prated + P_{sup})^{(1)(2)}$	II, package without hot water storage tank	II, package with hot water storage tank
0	0	0
0.1	0.3	0.37
0.2	0.55	0.70
0.3	0.75	0.85
0.4	0.85	0.94
0.5	0.95	0.98
0.6	0.98	1.00
≥ 0.7	1.00	1.00

(1) The intermediate values are calculated by linear interpolation between the two adjacent values.
(2) Prated is related to the preferential space heater or combination heater.

5.2 EC Declaration of conformity

This appliance complies with the standard type described in the EC declaration of conformity. It has been manufactured and commissioned in accordance with European and British directives.



You can go to the website for the declaration of conformity: <https://declaration-of-conformity.bdrthermeagroup.com>

Fig.20 QR code



AD-3001616-01

Original instructions - © Copyright

All technical and technological information contained in these technical instructions, as well as any drawings and technical descriptions supplied, remain our property and shall not be multiplied without our prior consent in writing. Subject to alterations.

 0345 070 1055

 www.baxi.co.uk

 Brooks House
Coventry Road
Warwick CV34 4LL

 01 459 0870

 www.baxi.ie

 Unit F 5&6,
Calmount Park, Calmount Road,
Ballymount, Dublin 12



CE
UK
CA

BAXI

