

## Technical specification

R-GEN 20/44 NG

### Ultra low NO<sub>x</sub> emission levels

< 40 mg/kWh (0% O<sub>2</sub>) \*

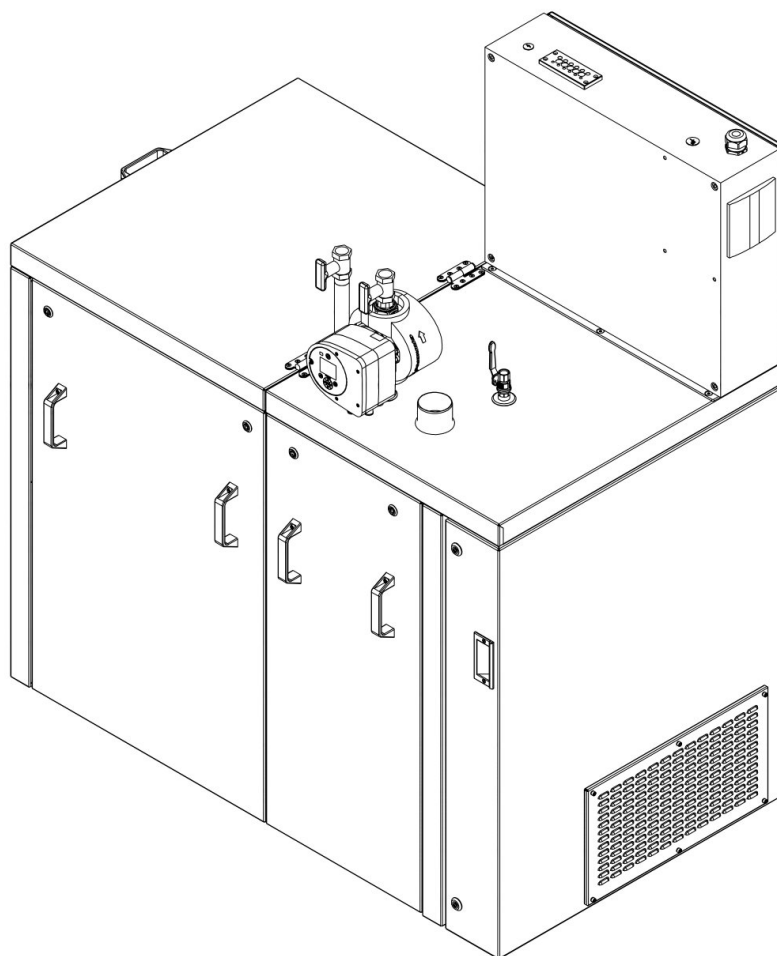

Design:

**20 kW el.**  
**400 V / 50 Hz**  
**natural gas**  
**Hi = 10,25 kWh/Nm<sup>3</sup>**  
**NO<sub>x</sub> < 40 mg/kWh**  
**Exhaust cooling to 40 °C**

\* Based on the energy input of the gas (calculated by higher heating value).

---

1 Genset	3
1.1 Engine	3
1.2 Generator (utility planning data)	4
2 Mixture composition	4
2.1 Combustion air	4
2.2 Fuel	5
3 Integrated heat extraction	5
3.1 Heating circuit	5
3.2 Engine circuit	5
4. Exhaust system	6
5 Sound reducing encapsulation	6
6 Operating fluids	6
7 Electronics and software	6
8 Interfaces	7
8.1 Dimensions and weights	7
8.2 Water / gas transfer points	8
8.3 Electrical connections / utility interface	8
8.4 Data interfaces	8
9 Technical boundary conditions	9

---

Subject to technical changes!

Note: Figure on cover page may differ

## 1 Genset

	50 %	75 %	100 %	Load
Electrical power	10	15	20	kW <sup>(5)</sup>
Recoverable thermal output	29	37	44	kW <sup>(2), (8)</sup>
Energy input	36	49	62	kW <sup>(1)</sup>
Efficiencies electrical	28,1	30,6	32,0	% <sup>(1)</sup>
Efficiencies thermal	81,5	75,3	70,4	% <sup>(1), (2), (8)</sup>
Efficiencies total (el. + th.)	109,6	106,0	102,4	% <sup>(1), (2), (8)</sup>
CHP coefficient	0,34	0,41	0,45	<sup>(1), (2), (8)</sup>

	NOx	CO	HCHO	
Exhaust emissions without catalytic converter	< 3600	< 8000	k.A	mg/Nm <sup>3</sup> <sup>(4), (6)</sup>
Exhaust emissions with catalytic converter *	< 40	< 150	< 20	mg/kWh <sup>(4), (6)</sup>

Internal consumption		< 0,6	kW
----------------------	--	-------	----

### 1.1 Engine

Engine manufacturer	Toyota		
Engine type	4Y		
Type	Reihe		
No. of cylinders	4		
Operating method	4-stroke		
Combustion process	$\lambda = 1$		
Engine displacement	2237	ccm	
Bore	91	mm	
Stroke	86	mm	
RPM	1500	1/min	
ISO standard power (mech.)	22	kW	
compression ratio	10,5 : 1		
average effective pressure	7,7	bar	
average piston speed	4,3	m/s	
body of balance wheel	-		
Direction of rotation (based on balance wheel)	left		
tooth rim with number of teeth	-		
Engine dead weight	122	kg	

\* With appropriate catalyst configuration! NOx emission based on catalyst in new condition.

## 1.2 Generator (utility planning data)

Manufacturer	Emod	
Type	WKASYG 225/4-120	
Generator type	Asynchronous, directly coupled	
Starting current (with frequency converter)	< 40	A
Rated speed	1540	1/min
Frequency	50	Hz
mechanical fuel shutoff	21	kW
Effective electrical power	20	kW
Apparent electrical power (compensated / uncompensated)	21 / 26	kVA
Rated generator current (compensated / uncompensated)	30 / 37	A
Rated generator voltage ( $\pm 10\%$ )	400	V
Cooling water inlet/outlet temperature (max.)	70 / 75	$^{\circ}\text{C}$
Short-circuit current $I_k''^3$	0,16	kA
Power factor $\cos \varphi$ (compensated / uncompensated)	0,95 ind. / 0,78 ind.	
Generator circuit breaker	50	A
Additional section switch (VDE-AR-N 4105)	50	A
Efficiency (full load) at $\cos \varphi = 0,78$	93,2	%
Mass moment of inertia	0,196	$\text{kg} \cdot \text{m}^2$
Ambient air temperature	85	$^{\circ}\text{C}$
Stator circuit	Dreieck	
Protection class	IP 55	
Generator weight	180	kg
Compensation	Optional	
Engine startup	Available	

## 2 Mixture composition

### 2.1 Combustion air

Combustion air mass flow	77	kg/h
Combustion air volume flow (25 $^{\circ}\text{C}$ , 1013 mbar)	65	$\text{m}^3/\text{h}$

### 2.2 Fuel

Fuel requirements in accordance with 'TA-004 Gas'

Reference methane number - minimum methane number	80 / 22	
Combustible mass flow	4,9	$\text{kg}/\text{h}$ <sup>(1)</sup>
Combustible volume flow	6,1	$\text{Nm}^3/\text{h}$ <sup>(6), (1)</sup>
Gas pressure at rated load min. *	20	mbar
Gas flow pressure at rated load max. *	100	mbar

\* At the inlet to the gas regulation line

### 3 Integrated heat extraction

#### 3.1 Heating circuit

Heating water requirements in accordance with 'TA-002 Heating circuit'

Heating water volume flow	1 - 3,5	m <sup>3</sup> /h
Generator heat	1	kW
Exhaust gas heat up to 40 °C	20	kW <sup>(8)</sup>
Heating water return temperature (max)	70	°C
Heating water flow temperature (max) **	80	°C
Safety valve	3	bar
Pressure reserve ca. *	300	mbar

#### 3.2 Engine circuit

Coolant requirements in accordance with 'TA-001 Coolant'

Coolant heat	23	kW <sup>(2)</sup>
Engine inflow temperature (min.)	80	°C
Engine exit temperature (max.)	88	°C
Balance inflow / exit (max.)	6	K
Recirculated coolant quantity (min.)	3,8	m <sup>3</sup> /h
Operating pressure (max.)	1,5	bar
Safety valve	1,5	bar

\* Up to / from module interface

\*\* Heating water supply temperature max. in partial load operation < 80 °C

#### 4. Exhaust system

Exhaust gas temperature downstream of engine	570	°C <sup>(3)</sup>
Exhaust temperature after exhaust heat exchanger	40	°C <sup>(3), (8)</sup>
exhaust gas volume flow wet	65	Nm <sup>3</sup> /h <sup>(6)</sup>
exhaust gas volume flow dry	54	Nm <sup>3</sup> /h <sup>(6)</sup>
exhaust gas mass flow wet	82	kg/h
exhaust gas mass flow dry	72	kg/h
Exhaust back pressure downstream of engine	50	mbar
Pressure reserve approx. *	10	mbar
Exhaust outlet noise after primary muffler **	83	dB <sup>(7)</sup>
Safety temperature limiter	100	°C

#### 5 Sound reducing encapsulation

sound encapsulation temperature (max.)	75	°C
sound pressure level ***	51	dB(A)

#### 6 Operating fluids

Lubricating oil approvals, see 'TA-003 Lubricating oil'

Lubrication oil consumption (max.)	0,23	g/kWh
Filling capacity lubricant (max.)	12	l
Lubricating oil volume auxiliary tank	30	l
Motor circuit coolant fill quantity approx. (module)	4,8	l

Coolant approvals, see 'TA-001 Coolant'

#### 7 Electronics and software

Grid protection device	DEIF AGC	
Grid protection software status	> 13141	
Control panel	4 line LCD	
Approval (depending on version)	VDE-AR-N 4105	
Protection class Control cabinet	IP 54	
Switch cabinet environmental temperature	0 - 35	°C
Switch cabinet relative air humidity (max.)	65	%

\* From module interface (exhaust heat exchanger / catalytic converter in standard version and new condition)

\*\* Total sound power level at full engine load in accordance with DIN 45635-11 Annex A

\*\*\* Average sound pressure level under open area conditions at distance of 1 m in accordance with DIN 45635

## 8 Interfaces

### 8.1 Dimensions and weights

(Figures may differ)

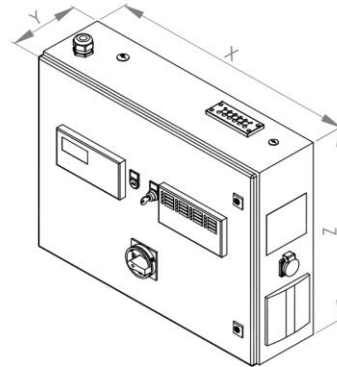
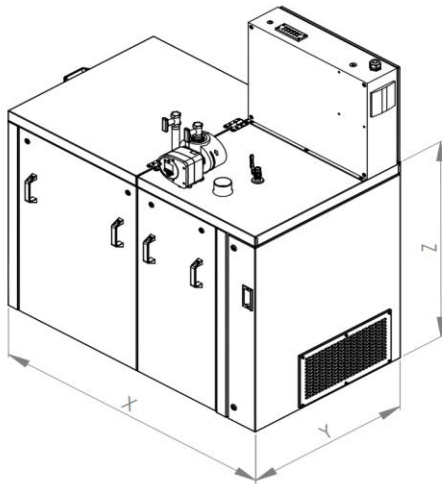

Length Module	X	1577	mm
Width Module	Y	929	mm
Height Module	Z	1220	mm
Weight Module (without operating fluids)		480	kg
Weight Module with sound reducing encapsulation		807	kg
Powder-coated CHP frame		RAL 6002	
Width Control cabinet	X	760	mm
Depth Control cabinet	Y	210	mm
Height Control cabinet	Z	600	mm
Weight Control cabinet		51	kg
Control cabinet powder coated		RAL 7035	

## 8.2 Water / gas transfer points

Interfaces Gas	3/4	"
Interfaces Exhaust	Ø 80	mm
Interfaces Heating circuit	1	"

## 8.3 Electrical connections / utility interface

Grid connection with pre-fuse (customer-provided)	400 V / 50 Hz	
Grid system	TN-S	
Short-circuit proof Icc (max.)	50	kA

## 8.4 Data interfaces

Remote maintenance access (optional) *	DSL / UMTS (SIM)	
Interfaces / Data interfaces (optional):	-	Profibus DP
	-	Profinet IO
	-	Modbus RTU
	-	Modbus TCP
	-	Ethernet IP
	-	Hardware signals
Access virtual power plant (optional)	Possible after technical clarification (bus or hardware signals)	

\* Access for remote maintenance must be provided by the customer



## 9 Technical boundary conditions

Unless otherwise specified, all data is based on full engine load with the respective indicated media temperatures and subject to technical improvements. The generator output measured at the generator terminals serves as the basis for the delivered electrical power. All power and efficiency specifications are gross specifications. The fuel gas quality must conform to the specifications of 'TA-004 Gas'. The operating fluids and plant system layout must conform to the 'Technical instructions' of 2G.

- (1) Performance conditions in accordance with DIN ISO 3046. Tolerance for specific fuel use amounts to + 5% of nominal performance. Efficiency specifications are based on an engine in new condition. An abatement in efficiency over the service life is reduced with observance of the maintenance requirements.
- (2) The tolerance for usable heat output is +/- 8 % under normal load.
- (3) The tolerance for the exhaust temperature is +/- 8 %.
- (4) Corresponding to a residual oxygen concentration in the exhaust of 5 %
- (5) Electrical generator terminal power at  $\cos \varphi = 1$ .
- (6) Volume specifications for normal status:

Pressure	1013 mbar
Temperature	0 °C
- (7) Standard deviation of reproducibility 4 dB in accordance with DIN EN ISO 3746
- (8) At heating water return temperature of 30 °C.  
The heating water supply temperature is approx. 25 °C higher than water return temperature.

Power specifications in this document relate to standard reference conditions.

### Standard reference conditions in accordance with DIN ISO 3046-1:

Air pressure	1000 mbar
Air temperature	25 °C
Relative air humidity	30 %

### Power reduction

Power reduction due to installation at altitude > 100m a.s.l. and/or air suction temperature > 25°C shall be determined specifically for each project according "TI-049 Load reduction".