

Construction Traffic Management Plan – Luddenham Road Gate 3

Western Sydney Airport – Surface and Civil Alignment Works

Project Name	Sydney Metro – Western Sydney Airport, Surface and Civil Alignment Works
Project Number	N81150
Revision Date	20 November 2023
Revision	6
Document Number	SMWSASCA-CPU-1NL-NL000-TF-PLN-000004

Document Approval

Rev	Date	Prepared by	Reviewed by	Approved by	Remarks
A	3/11/2022				External review
B	2/12/2022				See revision details table
C	22/12/2022				See revision details table
1					See revision details table
2	10 July 2023				See revision details table
3	7 August 2023				See revision details table
4	7 Sept 2023				See revision details table
5	27 October 2023				See revision details table
6	20 November 2023	See revision details table			
Signatures					

Distribution and Authorisation

Document Control

The CPBUI JV Project Director is responsible for ensuring this plan is reviewed and approved. The Construction Manager is responsible for updating this plan to reflect changes to the project, legal and other requirements, as required.

The controlled master version will be maintained on Teambinder. All circulated hard copies are deemed to be uncontrolled.

Amendments

The implementation of this Plan is under the authority of the CPBUI Delegated Authority Matrix. All Contract personnel will perform their duties in accordance with this Plan, supporting plans, and related procedures.

Revision Details

Rev.	Details
A	For external review
B	For approval. Revised per Sydney Metro Review Comments.
C	For approval. Revised per Sydney Metro Review Comments
1	Approved
2	For approval – changes to gate access on Luddenham Road to facilitate piling rig movements including short term TGS
3	For approval – Revised per Sydney Metro Review Comments and changes to the egress location
4	For approval – load limit requirements restrict piling rig removal to Luddenham Road gate only
5	Clarification of movements for all vehicles – piling rig removal as per version 4.
6	No change to submission as reversing swept paths are not possible

Table of contents

Abbreviations and definitions	iv
Part A Overview	6
1. Introduction	6
1.1. Project Scope.....	6
1.1.1. Surface, Civil and Alignment Works (SCAW) scope	6
1.2. Plan Purpose and Objectives.....	8
2. Locality and existing conditions.....	9
2.1. Luddenham Road, Luddenham.....	11
3. Site works	12
3.1. Works required.....	12
3.2. Operating conditions	12
3.2.1. Impact on traffic flow.....	12
3.2.2. Impact on public transport	13
3.2.3. Impact on active transport users	13
3.2.4. Impact on property and utilities access	13
3.2.5. Cumulative impacts	14
3.3. Staff and labour parking	14
3.4. Traffic Guidance Schemes.....	14
3.5. Required Council approvals	14
4. Fleet management.....	15
4.1. Haulage routes.....	16
4.2. Road dilapidation report.....	16
4.3. Permits for over-dimensional vehicles	16
5. Other matters	18
5.1. Road Safety Audits	18
5.2. Communications and the community.....	18
5.2.1. Proposed communications	18
5.2.2. Travelling public.....	18
5.3. Stakeholders	18
5.3.1. Traffic and Transport Liaison Group.....	19
5.3.2. Traffic Control Group	20
5.4. Special events.....	20
5.5. Training	20
5.6. Inspections and monitoring	20
5.7. Site contacts	20
5.8. References.....	21
Part C Appendices.....	22
Appendix A Compliance Matrix.....	22
Appendix B Briefing paper	25
Appendix C Haulage routes.....	26

Appendix D Swept paths	27
Appendix E Traffic Guidance Scheme.....	28
Appendix F Road Safety Audit	29
Appendix G Stakeholder comments	30
Appendix H Checklists.....	31

List of figures

Figure 1: Surface Civil and Alignment Works	6
Figure 2: Luddenham Road access point	8
Figure 3: Existing access	8
Figure 4 Road network surrounding the project	9
Figure 5: Existing cycle network	10
Figure 6: EIS haulage routes from the north	15
Figure 7: From the M4 Motorway for access	25

List of tables

Table 1 Abbreviations and definitions	iv
Table 2: EIS predicted vehicle numbers	11
Table 3: CPBUI JV vehicle numbers	12
Table 4: Proposed communications	17
Table 5: Consultation undertaken	18
Table 6: Site contacts	20

Abbreviations and definitions

Table 1 Abbreviations and definitions

Abbreviation	Description
CJP	Customer Journey Planning (formerly SCO)
CPB	CPB Contractors Pty Ltd
CPBUI JV	CPB Contractors Pty Limited and United Infrastructure Pty Limited Joint Venture
CTMF	Construction Traffic Management Framework (an appendix of the EIS)
CTMP	Construction Traffic Management Plan
HML	Higher Mass Limit
HVNL	Heavy Vehicle National Law
IAP	Intelligent Access Program
LTC	Local Traffic Committees
OSOM	Oversize and/or over mass
PedMP	Pedestrian Management Plan
PMP	Project Management Plan
PMS	Project Management System
PkMP	Parking Management Plan
QR	Quick Response
RAV	Restricted Access Vehicle
ROL	Road Occupancy Licence
RSA	Road Safety Audit
SBT	Sydney Metro – Western Sydney Airport, Station Boxes and Tunnelling package
SCAW	Western Sydney Airport Surface and Civil Alignment Works package
SCO	Sydney Coordination Office (now CJP)
SSTOM	Sydney Metro – Western Sydney Airport, Stations, Systems, Trains, Operations and Maintenance package
SWTC	Scope of Work and Technical Criteria
TCG	Transport Coordination Group
TCP	Traffic Control Plan now known as Traffic Guidance Scheme
TfNSW	Transport for New South Wales
TGS	Traffic Guidance Scheme (formerly TCP)
TTLG	Traffic and Transport Liaison Group
UI	United Infrastructure Pty Limited
VMP	Vehicle Movement Plan
VMS	Variable message signs
WSA	Western Sydney Airport
WSI	Western Sydney International

Part A Overview

1. Introduction

1.1. Project Scope

The SMWSA Project involves the construction and operation of a new 23km metro rail line that extends from the existing Sydney Trains suburban T1 western line (at St Marys) in the north to the Aerotropolis (at Bringelly) in the south. The alignment includes a combination of tunnels and civil structures, including viaducts, bridges, and surface and open-cut troughs between the two tunnel sections. The Project also includes six new metro stations, and a stabling and maintenance facility and operational control centre at Orchard Hills. The SCAW package is the second major contract package to be procured for the Project. The successful and timely completion of the SCAW package is critical to the subsequent construction activities and ultimate completion of the entire Project.

1.1.1. Surface, Civil and Alignment Works (SCAW) scope

The scope for the SCAW package includes approximately 10.6km of alignment up to the underside of track formation from Orchard Hills to the WSI airport. This includes approximately:

- 3.6km of viaduct
 - 400m of viaduct over Blaxland Creek
 - 660m of viaduct over the Patons Lane area and un-named creek
 - 2.5km of viaduct in the Luddenham Road area including across the Warragamba pipeline, at Luddenham Station, across Luddenham Road and across Cosgrove Creek
- 205m of bridges
 - An over rail bridge, approximately 180m long, over the proposed M12 Motorway
 - An over rail bridge, approximately 25m long, over the drainage swale on the WSI airport site
- 6.9km of at-grade alignment
 - 600m at Orchard Hills, south of Lansdowne Road
 - 1.6km alongside the stabling maintenance facility in Orchard Hills
 - 900m to the north of the Warragamba pipelines
 - 1.1km north of the proposed M12 motorway
 - 1.4km south of the proposed M12 Motorway on Elizabeth Drive
 - 1.3km within the Airport site from the northern boundary to the Airport Business Park Station
- Temporary and permanent access roads.

The scope of works can be seen on Figure 1, noting that the tunnel and station works are by others.

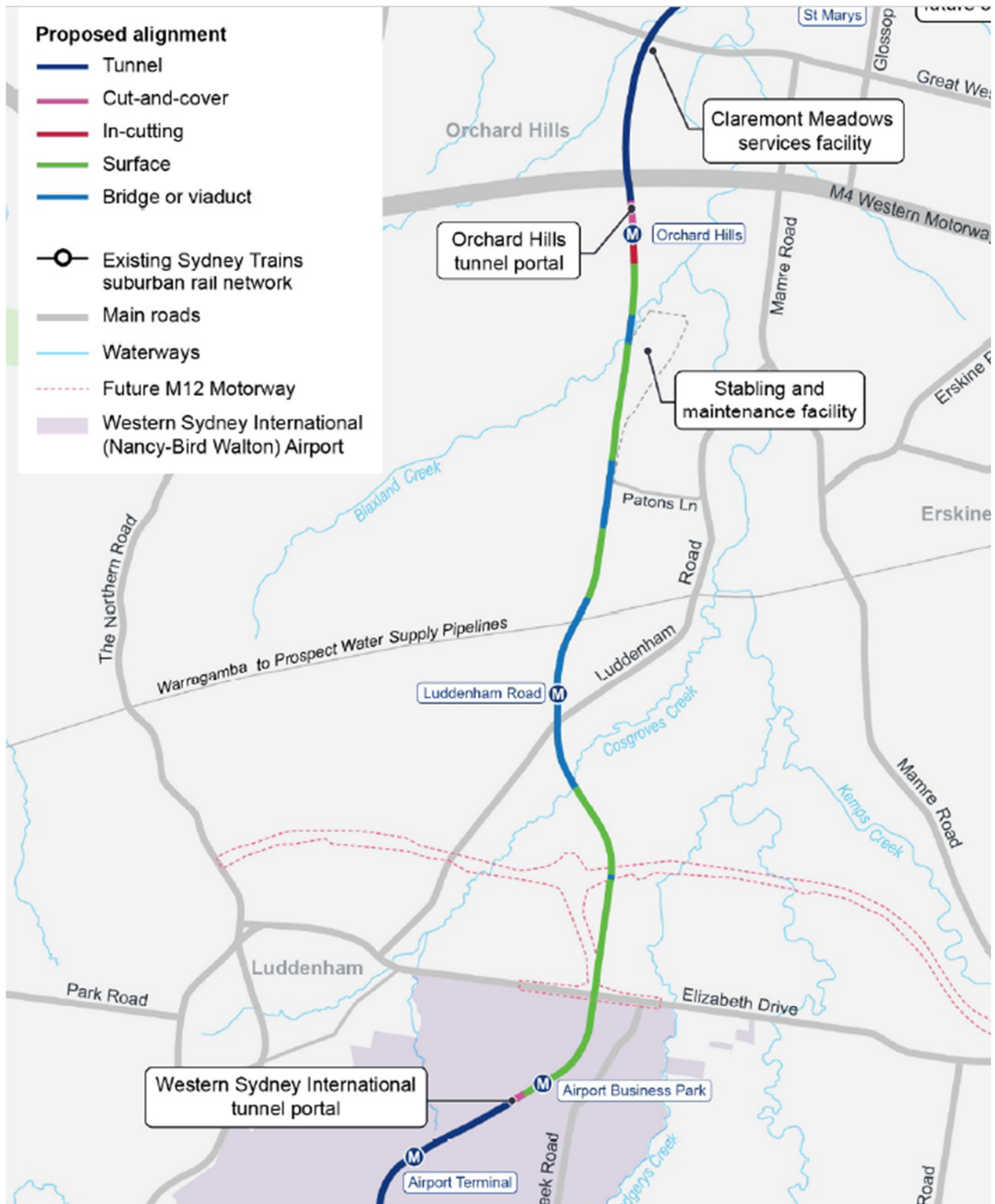

Figure 1: Surface Civil and Alignment Works

1.2. Plan Purpose and Objectives

The Luddenham Road Construction Traffic Management Plan Gate 3 (CTMP or this plan) has been developed by CPB Contractors, United Infrastructure Joint Venture (CPBUIJV) to identify the traffic management measures at the Luddenham Road access point for all phases of works associated with the Sydney Metro Western Sydney Airport Surface Civils and Alignment Works (SCAW works).

The plan sets out the traffic management initiatives that will be deployed to minimise disruption and ensure the safety of the wide range of stakeholders potentially affected by the SCAW works including but not limited to motorists, pedestrians, cyclists, public transport users, local residents, property owners, business owners and workers/ staff.

This plan has been prepared in accordance with the Construction Traffic Management Framework, SSI 10051 Planning Approval Condition E103 and will be submitted to the Planning Secretary of the NSW Department of Planning and Environment for information prior to the commencement of activities noted in the CTMP.

The key objectives of this plan are to ensure:

- The provision of a safe environment for road users, pedestrians, cyclists and workers
- Any impact on road users is kept to a minimum
- Access is maintained for the local community, transport operators and commercial developments
- Works are staged on key parts of the network to maintain levels of service
- The SCAW package is represented as a proactive member of relevant local traffic coordination groups
- Road users, local businesses, local Councils, Emergency Services, stakeholders and local communities are informed to changed traffic conditions, and
- There is sufficient advance warning of changes to normal traffic conditions.

2. Locality and existing conditions

The site is located on the western side of Luddenham Road, refer to Figure 2.



Figure 2: Luddenham Road access point

The existing access point will be used between the two pipelines, refer to Figure 3



Figure 3: Existing access

The road network surrounding the access points are as noted on Figure 4.

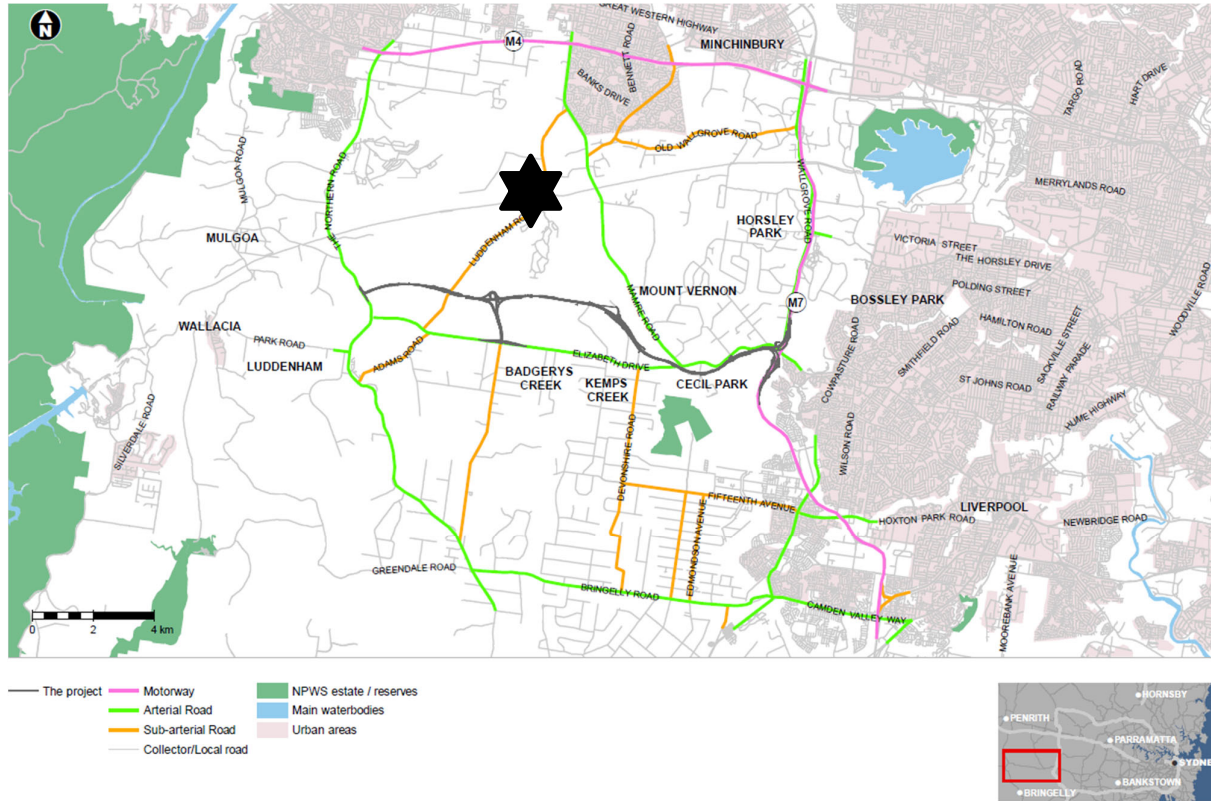

Figure 4 Road network surrounding the project

2.1. Luddenham Road, Luddenham

Luddenham Road is a regional road. Regional roads typically fall under council care with control of the road exercised between Council and TfNSW with TfNSW agreement required for any regulatory changes. Luddenham Road runs in a north-south direction. Luddenham Road terminates to the north at Mamre Road and to the south at Elizabeth Drive. It has a speed limit of 70km/hr near the work area. There is no on street parking along Luddenham Road. There are no existing footpaths or off road cycle facilities along Luddenham Road, refer to Figure 5.

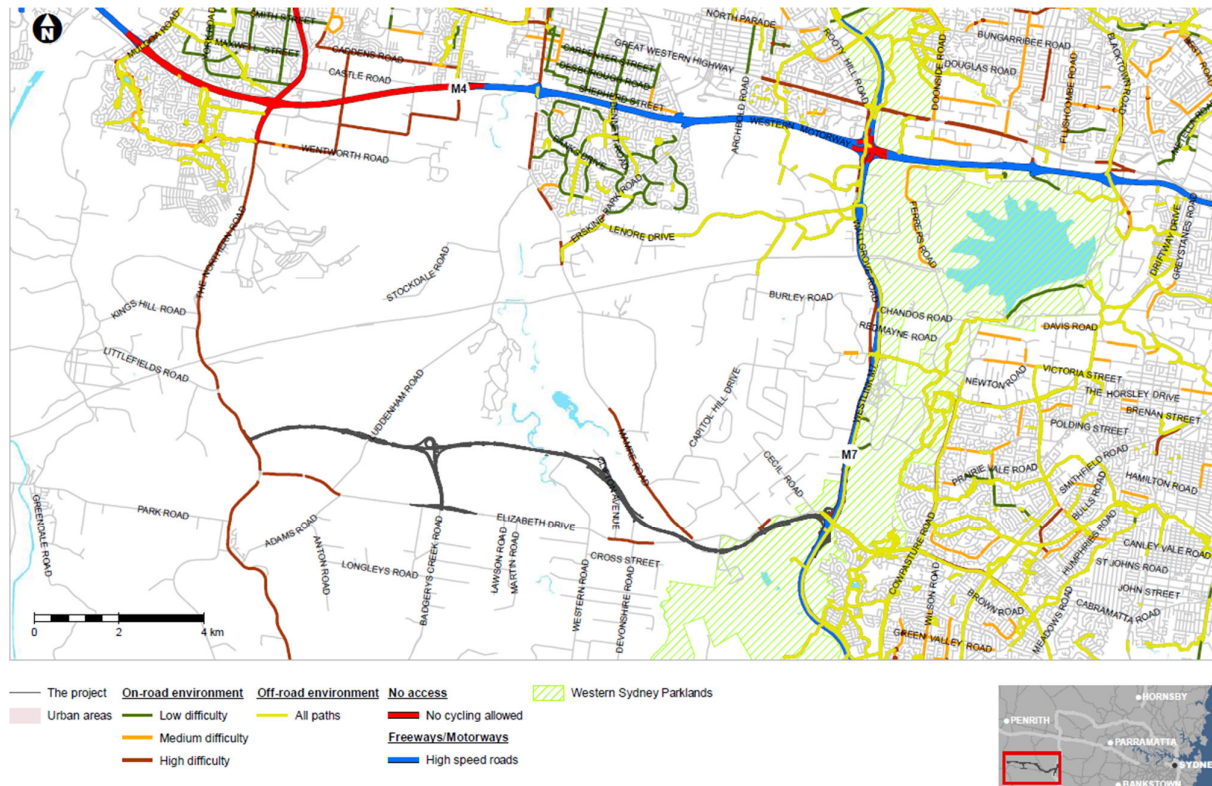

Figure 5: Existing cycle network

Two school buses use Luddenham Road one runs in the morning and the other in the afternoon.

3. Site works

Duration: approximately 24 months

Timing: December 2022 -December 2024

3.1. Works required

Works to be undertaken during the site main works include:

- Minor earthworks
- Construction of a piling platform
- Construction of a monopile
- Access for structures – light vehicle during viaduct construction over the pipeline.
- Reinstatement of an access track
- Minor revegetation
- Access gate changes – approximately 1 week

Works will generally be undertaken between the hours of 7AM-6PM Monday to Friday and 8AM-1PM Saturday.

Earthworks and site investigation works will commence December 2022 with the indicative program dates for the structure works (subject to change) are:

- Access and enabling works: September/ October-2023
- Piling and Substructure: October 2023 to December 2023
- Superstructure and Finishing: Jul-2024 to Aug-2024

3.2. Operating conditions

Vehicles will enter and exit the site via Luddenham Road. Heavy vehicles will enter via a right turn into site and leave via a left turn. Light vehicles will enter and exit via left turns. The gate will be manned during arrival and departure of heavy vehicles. Piling rig delivery and removal will be via Luddenham Road with the delivery of the piling rig turning right from Luddenham Road into the pipeline area. Removal of the piling rig will require the vehicle to reverse into the site from Luddenham Road under traffic control. Once loaded the low loader will enter Luddenham Road in a forward direction. Other deliveries for the works will enter via Luddenham Road and exit via The Northern Road.

3.2.1. Impact on traffic flow

The EIS indicative peak hour vehicle numbers associated with the site operations phase of works are provided in Table 2.

Table 2: EIS predicted vehicle numbers

	Vehicle Type	Peak construction movements ¹					
		AM PEAK ²			PM PEAK ³		
		IN	OUT	Total	IN	OUT	Total
	LV Staff	281	0	281	0	281	281

¹ Per hour

² AM peak as noted in the EIS 730-830AM

³ PM peak as noted in the EIS 430-530PM

	Vehicle Type	Peak construction movements ¹					
		AM PEAK ²			PM PEAK ³		
		IN	OUT	Total	IN	OUT	Total
Off airport construction corridor ⁴	LV Deliveries	4	4	8	4	4	8
	HV	29	29	58	29	29	58

CPBUI JV vehicle numbers are provided in Table 3 . It should be noted that the bulk of the workforce will arrive to the site prior to 7AM and leave the site after 6PM.

Table 3: CPBUI JV vehicle numbers

	Vehicle Type	Peak construction movements ¹					
		AM PEAK			PM PEAK		
		IN	OUT	Total	IN	OUT	Total
Gates 3 Pipeline access on Luddenham Road	LV Staff	5	0	5	5	0	5
	LV Deliveries	1	1	2	1	1	2
	HV	1	1	2	1	1	2

Based on a standard 10 hour day there will be 2 heavy vehicle per hour maximum outside of the AM and PM peaks with light vehicle movements generally taking place prior to the commencement of the work day and at the end of the work day. As noted the CPBUI JV vehicle numbers are below those predicted in the EIS.

Access for the piling rig associated with the viaduct works will require the existing gate off Luddenham Road to be widened. The delivery and removal of the piling rig will require traffic control on Luddenham Road to facilitate the vehicle movements. The TGS associated with the piling rig movements will occur outside of peak hours. Steel deliveries will enter via Luddenham Road and exit via The Northern Road.

3.2.2. Impact on public transport

There is no impact on public transport during these works as there are limited services that operate in the area, as noted in section 2.1. No bus stops or services will be affected by the works

3.2.3. Impact on active transport users

There are no existing footpaths or cycles routes provided along Luddenham Road..

3.2.4. Impact on property and utilities access

Access to residential-and commercial properties will be retained during the site establishment works and ancillary facilities (compounds) operations. Access for utility providers/ maintainers will not be impacted.

Any property access that is physically affected by the Project Works will be reinstated to at least an equivalent standard, in consultation with the landowner or alternative access provided in consultation with the landowner.

During construction, all reasonably practicable measures will be implemented to maintain pedestrian and vehicular access to, and parking in the vicinity of, residences, businesses and affected properties.

⁴ Off airport includes Luddenham Road, Elizabeth Drive and Badgerys Creek Road sites
 CPBUI JV_SMWSA_SCAW | Construction Traffic Management Plan – Luddenham Road Gate 3
 Commercial-in-Confidence

Disruptions will be avoided, where possible and where avoidance is not possible, minimised. Where disruption cannot be minimised, alternative pedestrian and vehicular access, and parking arrangements will be developed in consultation with affected residents, businesses and affected property owners and implemented before the disruption. Adequate signage and directions to businesses will be provided before, and for the duration of, any disruption.

Existing property access would be maintained at all times.

Any changes to access arrangements or alternative access that are necessary during construction will be done in with consultation with the landowner. Any changes to access will provide the same equivalent pre-existing level of access unless agreed to by the land owner. Property access that is physically affected by the project will be reinstated to at least an equivalent standard, in consultation with the landowner.

3.2.5. Cumulative impacts

Endeavour Energy is currently working along Luddenham Road. The operation of Gates 4 and 5 (further south on Luddenham Road) and specifically Gate 5 requires for vehicles to enter the site from the northern section of Luddenham Road. It is noted that there is proposed to have only 1 heavy vehicle operate during the AM and PM peak periods, therefore the cumulative impact is minimal for the operation of this gate.

3.3. Staff and labour parking

All vehicles associated with the works will park within Patons Lane compound and be transported to and from the site.

3.4. Traffic Guidance Schemes

Traffic Guidance Schemes for:

- Stop slow on Luddenham Road for gate changes and access/ egress for the piling rig

3.5. Required Council approvals

Penrith City Council and TfNSW are the approval authorities for access off Luddenham Road.

4. Fleet management

Trucks to be used for the delivery of the SCAW works will be compliant with NSW legislation and standards including Heavy Vehicle National Legislation (HVNL). All heavy vehicle operations will be conducted in accordance with CPBUI JV Chain of Responsibility (CoR) Management Plan and the Principal's Contractors Safety Standard as noted in the Overarching TMP.

A combination of truck types will be used during the SCAW works including single unit trucks, semi-trailers, truck and dog combinations and low loaders, for example.

The location of all heavy vehicles used for spoil haulage will be monitored in real time and these records can be made available electronically to the Planning Secretary and the Environmental Protection Authority (EPA) upon request for a period of no less than one (1) year following the completion of construction.

There is sufficient room on site for all heavy vehicles required for the works. Therefore, marshalling facilities are not proposed for this site. Heavy vehicle will not idle or queue on roads surrounding the site.

4.1. Haulage routes

Generally, the haulage route will be via arterial roads, freeways or tollways. The routes included in the EIS have been adopted for this site, refer to Figure 6. The route include Luddenham Road from the north, . CPBUI JV will predominately use Luddenham Road from the north for material delivery and removal. Heavy vehicles will be accessing the arterial network after leaving the construction sites.

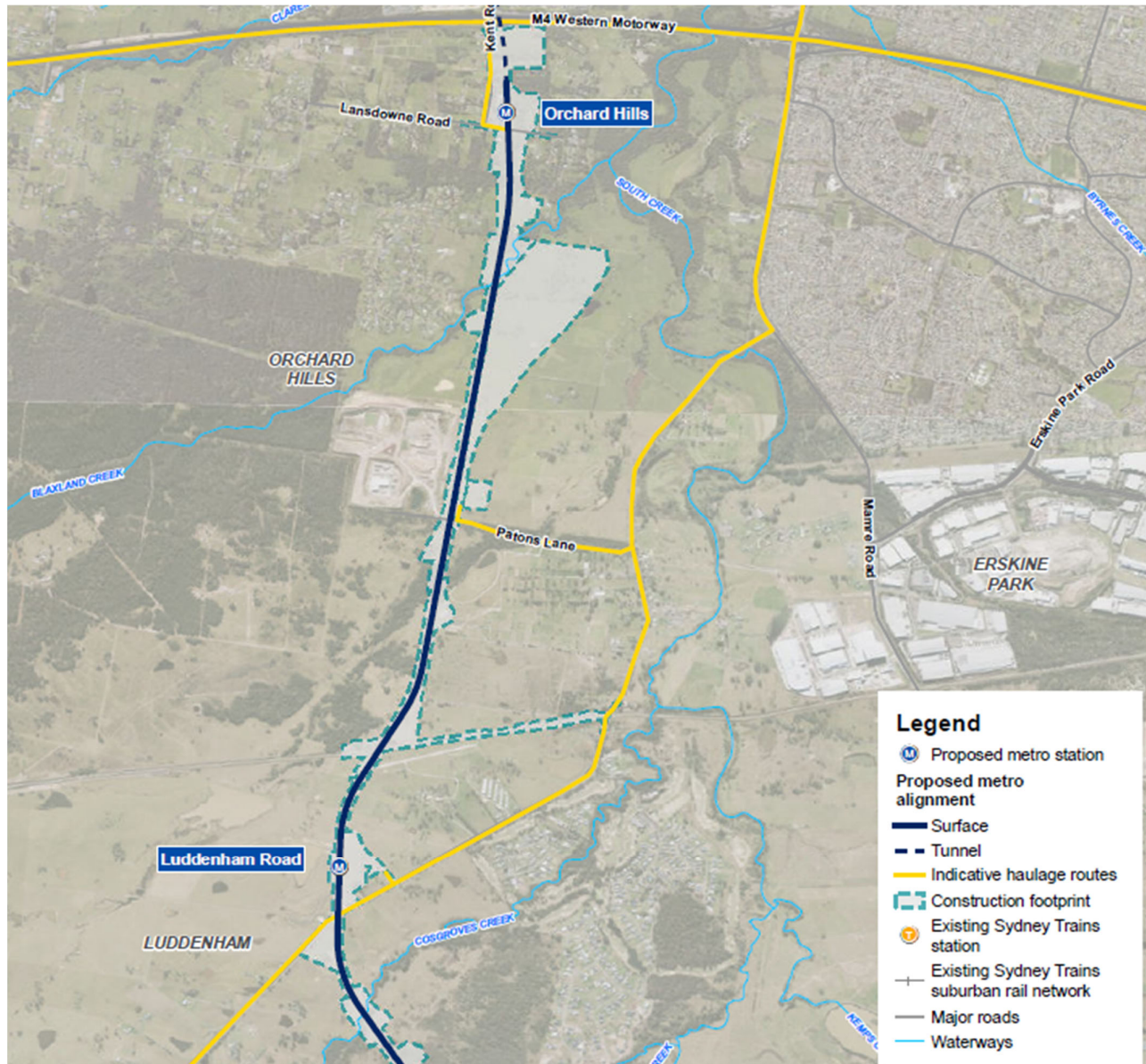

Figure 6: EIS haulage routes from the north

4.2. Road dilapidation report

As noted in the Ministerial Conditions of Approval, road dilapidation report has been prepared for local roads and provided to Penrith City Council.

4.3. Permits for over-dimensional vehicles

Permit for vehicles greater than 4.5t through the National Heavy Vehicle Regulator (NVHR). This applies to particular special purpose vehicles (OSOM) such as mobile cranes and other oversize/ over mass (OSOM) vehicles. TfNSW is currently taking this permit issue.

For over dimensional vehicles generally vehicles that are greater than 25m in length of 3.5m wide require a pilot(s). Extremely long or wide vehicles will require an escort, fee payable. Permits are generally applied for by the transport operator.

There is a requirement for over mass/ oversize vehicles during the works identified in this CTMP.

5. Other matters

5.1. Road Safety Audits

Road safety audits will be undertaken during the development and implementation of the CTMP. The audit will be undertaken as noted in section 10 of the Construction Traffic Management Framework. A copy of the road safety audit is provided in Appendix D.

5.2. Communications and the community

CPBUI JV will be responsible for the dissemination of information to the community including affected residents, relevant councils, businesses and the public.

5.2.1. Proposed communications

Typical timelines for the various notifications are:

- Community notices (notifications) issued at least seven (7) days prior to:
 - Start of work
 - New work with a new activity that has the potential to impact on stakeholders and the community
 - Handover of a construction site to a new contractor
 - Activities requiring notification to comply with relevant Environmental Protection License (EPL) usually out of hours works
- Precinct updates/ e-update (newsletters) – published 2 per year and for changes to planning approvals
- email and internet updates - done with publication and deliver to letterboxes of notifications and newsletters
- advertisement – published in advance of significant traffic management changes, detours, traffic disruptions
- advance warning signs – as noted in the CTMP where required.

Table 4: Proposed communications

Notification	Site early works	Site operations
Community notice	Yes	Yes
Precinct update/ e-update	Yes	Yes
Email and internet	Yes	Yes
Print advertising	No	No
Advance warning sign(s)	No	No
Gate signs	No	No

5.2.2. Travelling public

Where the SCAW works will impact on the travelling public, CPGUI JV will undertake the following communications:

- Public transport interruptions will be communicated via on site signage
- Motoring public will be forewarned of any changes including road closures, road changes and lane changes well in advance using appropriate signs including Variable Message Signs (VMS)
- Active transport users will be provided with advance warning signs

5.3. Stakeholders

There are a number of stakeholders consulted during the development of this CTMP. A copy of their review comments are provided in Appendix C. Table 5 provides an overview of the consultation undertaken for this CTMP.

Table 5: Consultation undertaken

Stakeholder	Consultation Type	Date
CJP	Submission of CTMP	3 rd November 2022
Sydney Metro Western Sydney Airport project team	Submission of CTMP	3 rd November 2022
Penrith City Council	Submission of CTMP	3 rd November 2022
TfNSW	Submission of CTMP	3 rd November 2022
CJP	Resubmission of CTMP	13 th December 2022
Sydney Metro Western Sydney Airport project team	Resubmission of CTMP	13 th December 2022
Penrith City Council	Resubmission of CTMP	13 th December 2022
TfNSW	Resubmission of CTMP	13 th December 2022
Water NSW	Warragamba Dam induction	
	Notice of intent to Enter form submitted	
	Early works access license received	
	Site walk through undertaken	
CJP	Resubmission of CTMP	10 th July 2023
Sydney Metro Western Sydney Airport project team	Resubmission of CTMP	10 th July 2023
Penrith City Council	Resubmission of CTMP	10 th July 2023
TfNSW	Resubmission of CTMP	10 th July 2023
CJP	Resubmission of CTMP	7 th August 2023
Sydney Metro Western Sydney Airport project team	Resubmission of CTMP	7 th August 2023
Penrith City Council	Resubmission of CTMP	7 th August 2023
TfNSW	Resubmission of CTMP	7 th August 2023
CJP	Resubmission of CTMP	7 th September 2023
Sydney Metro Western Sydney Airport project team	Resubmission of CTMP	7 th September 2023
Penrith City Council	Resubmission of CTMP	7 th September 2023
TfNSW	Resubmission of CTMP	7 th September 2023
CJP	Resubmission of CTMP	27 October 2023
Sydney Metro Western Sydney Airport project team	Resubmission of CTMP	27 October 2023
Penrith City Council	Resubmission of CTMP	27 October 2023
TfNSW	Resubmission of CTMP	27 October 2023
CJP	Resubmission of CTMP	20 November 2023
Sydney Metro Western Sydney Airport project team	Resubmission of CTMP	20 November 2023
Penrith City Council	Resubmission of CTMP	20 November 2023
TfNSW	Resubmission of CTMP	20 November 2023

5.3.1. Traffic and Transport Liaison Group

The Traffic and Transport Liaison Group (TTLG) has been established by Sydney Metro Western Sydney Airport for the project, as required under MCoA E116. The TTLG consists of members from Sydney Metro Western Sydney Airport project team, Liverpool City Council, Penrith City Council, Customer Journey Planning, Western Sydney Airport Corporation (WSA Co), Western Parkland City

Authority (WPCA), TfNSW's Planning and Programs, other contractors associated with the project and Emergency Services.

Further development of this CTMP will occur in consultation with this group. It is noted that this group meets monthly.

Supplementary analysis and modelling as required by Sydney Metro Western Sydney Airport and/ or the TTLG will be undertaken to demonstrate that construction traffic can be managed to minimise disruption to traffic networks operations including changes to the management of pedestrians, cyclists and public transport networks and services. Any revised traffic management measure will be incorporated into the CTMP.

5.3.2. Traffic Control Group

The Traffic Control Group (TCG) has been established by Sydney Metro Western Sydney Airport for the project. The TCG consists of members from Sydney Metro Western Sydney Airport project team, Liverpool City Council, Penrith City Council, Customer Journey Planning, Western Sydney Airport Corporation (WSA Co), Western Parkland City Authority (WPCA), TfNSW's Planning and Programs and other contractors associated with the project. The TCG meets fortnightly.

The purpose of the TCG is for open and honest technical discussion on the contractors proposed works, methodologies and traffic management plans. The TCG will:

- Provide feedback on proposals
- Guide CTMP and other document finalization prior to submission for review/ approval
- Guide coordination of works and traffic management activities on and off airport (local, regional and state roads)
- Assist in transport mitigation

5.4. Special events

When planning the works, CPGUI JV will identify special events which directly impact the works or haulage activities and will continue to interrogate event websites that provide details on forthcoming events such as:

- NSW and Sydney events - [Destination NSW](#)
- NSW events and festivals - [Visit NSW](#)
- Major events - [Penrith City Council Upcoming events](#)

5.5. Training

CPBUI JV will ensure that all personnel, including subcontractors are aware of the specific requirements of TfNSW's customers, general public, residents and businesses, prior to attending site through the induction process and regular updates through tool box talks. Specific training will be provided to heavy vehicle drivers regarding the possible presence of pedestrians and cyclists and the increased risk of high speed run off the road and head on collision types due to the narrow road widths, high speeds and little to no shoulder availability. If a pedestrian or cyclist is present near the access road, priority will be provided to those active users and this will be communicated through the induction process.

5.6. Inspections and monitoring

The site will be monitored by the site supervisor. Any changes to signs and lines that impact on the public will be recorded. Daily monitoring will be undertaken during the site operating hours.

Traffic control used for pedestrian management, lane closures etc will need to provide records of the traffic control implemented. Any changes required to a traffic control set up will be authorised by a holder of a SafeWork NSW "Prepare a Work Zone Traffic Management Plan" or equivalent. Checklist for monitoring of the implemented CTMP are provided in Appendix D.

5.7. Site contacts

Table 6 provides the contact details for the works identified in this CTMP.

Table 6: Site contacts

Name	Position	Mobile#
[Redacted]		

5.8. References

The following documents were used in the development of this CTMP:

- Construction Traffic Management Framework, Sydney Metro West and Sydney Metro Western Sydney Airport
- TfNSW's Traffic Control at Worksites Manual v6.1
- Relevant AustRoads Guides and TfNSW Supplements
- Sydney Metro Principal Contractor Health and Safety Standard

Part C Appendices

Appendix A Compliance Matrix

Sydney Metro Western Sydney Airport CSSI Infrastructure Approval (SSI 10051)

Project Planning Approval (SSI 10051)		
E103	Construction Traffic Management Plans (CTMPs) must be prepared in accordance with the Construction Traffic Management Framework. A copy of the CTMPs must be submitted to the Planning Secretary for information before the commencement of any construction in the area identified and managed within the relevant CTMP.	This plan
E104	The locations of all Heavy Vehicles used for spoil haulage must be monitored in real time and the records of monitoring be made available electronically to the Planning Secretary and the EPA upon request for a period of no less than one (1) year following the completion of construction.	Refer to Overarching CTMP
E105	Local roads proposed to be used by Heavy Vehicles to directly access ancillary facilities / construction sites that are not identified in the documents listed in Condition A1 must be approved by the Planning Secretary and be included in the CTMP.	Not applicable to this CTMP as all roads to be used are included in the EIS
E106	All requests to the Planning Secretary for approval to use local roads under Condition E105 above must include the following: (a) a swept path analysis; (b) demonstration that the use of local roads by Heavy Vehicles for the CSSI will not compromise the safety of pedestrians and cyclists of the safety of two-way traffic flow on two-way roadways; (c) details as to the date of completion of the road dilapidation surveys for the subject local roads; and (d) measures that will be implemented to avoid where practicable the use of local roads past schools, aged care facilities and child care facilities during their peak operation times; and (e) written advice from an appropriately qualified professional on the suitability of the proposed Heavy Vehicle route which takes into consideration items (a) to (d) of this condition.	Not applicable to this CTMP as all roads to be used are included in the EIS
E107	Before any local road is used by a Heavy Vehicle for the purposes of construction of the CSSI, a Road Dilapidation Report must be prepared for the road. A copy of the Road Dilapidation Report must be provided to the Relevant Road Authority(s) within three (3) weeks of completion of the survey and at no later than one (1) month before the road being used by Heavy Vehicles associated with the construction of the CSSI.	Section 4.2
E108	If damage to roads occurs as a result of the construction of the CSSI, the Proponent must either (at the Relevant Road Authority's discretion): (a) compensate the Relevant Road Authority for the damage so caused; or (b) rectify the damage to restore the road to at least the condition it was in pre-work as identified in the Road Dilapidation Report.	Section 4.2
E109	Vehicles associated with the project workforce (including light vehicles and Heavy Vehicles) must be managed to: (a) minimise parking on public roads; (b) minimise idling and queueing on state and regional roads; (c) not carry out marshalling of construction vehicles near sensitive use	Section 4

Project Planning Approval (SSI 10051)		
	(d) not block or disrupt access across pedestrian or shared user paths at any time unless alternate access is provided; and (e) ensure spoil haulage vehicles adhere to the nominated haulage routes identified in the CTMP.	
E110	Access to all utilities and properties must be maintained during works, unless otherwise agreed with the relevant utility owner, landowner or occupier.	Section 3.2.4
E111	The Proponent must maintain access to properties during the entirety of works unless an alternative access is agreed in writing with the landowner(s) whose access is impacted by the CSSI works.	Section 3.2.4
E112	Where construction of the CSSI restricts a property's access to a public road, the Proponent must, until their primary access is reinstated, provide the property with temporary alternate access to an agreed road decided through consultation with the landowner, at no cost to the property landowner, unless otherwise agreed with the landowner.	Section 3.2.4
E113	Any property access physically affected by the CSSI must be reinstated to at least an equivalent standard, unless otherwise agreed by the landowner or occupier. Property access must be reinstated within one (1) month of the work that physically affected the access is completed or in any other timeframe agreed with the landowner or occupier.	Section 3.2.4
E114	During construction, all reasonably practicable measures must be implemented to maintain pedestrian, cyclist and vehicular access to, and parking in the vicinity of, businesses and affected properties. Disruptions are to be avoided, and where avoidance is not possible, minimised. Where disruption cannot be minimised, alternative pedestrian, cyclist and vehicular access, and parking arrangements must be developed in consultation with affected businesses and landowners and implemented before the disruption. Adequate signage and directions to businesses must be provided before, and for the duration of, any disruption.	Sections 3.2.3 and 3.2.4
E115	Safe pedestrian and cyclist access must be maintained around the St Marys construction site during construction. In circumstances where pedestrian and cyclist access is restricted or removed due to construction activities, a proximate alternate route which complies with the relevant standards, must be provided and signposted before the restriction or removal of the impacted access.	Not applicable to the SCAW scope of works
E116	A Traffic and Transport Liaison Group(s) must be established in accordance with the Construction Traffic Management Framework to inform the development of CTMP.	Sydney Metro will establish the TTLG Section 5.3.1
E117	Supplementary analysis and modelling as required by TfNSW and / or the Traffic and Transport Liaison Group(s) must be undertaken to demonstrate that construction and operational traffic can be managed to minimise disruption to traffic network operations including changes to and the management of pedestrian, bicycle and public transport networks, public transport services, and pedestrian and cyclist movements. Revised traffic management measures must be incorporated into the CTMP.	Section 5.3.1
E118	As part of Condition E117 the Traffic and Transport Liaison Group(s) is to identify opportunities to improve the intersection performance during operation at:	Not applicable to the SCAW scope of works

Project Planning Approval (SSI 10051)

	<p>a) Queen Street/Great Western Highway/Mamre Road in St Marys; b) Glossop Street/ Forrester Road in St Marys; and c) Glossop Street / Great Western highway in St Marys. Identified improvements must be implemented prior to the commencement of operation.</p>	
--	---	--

Sydney Metro Western Sydney Airport Environmental Impact Statement

Revised Environmental Management Measures (REMMs)

T1	Construction Traffic Management Plans would be prepared in accordance with the Construction Traffic Management Framework	This plan
T2	The Construction Traffic Management Plan for St Marys would be developed in consultation with the Traffic and Transport Liaison Group to ensure existing transport interchange infrastructure continues to operate effectively within the St Marys station precinct.	Not applicable to the SCAW scope of works
T3	Coordination with Western Sydney Airport and Transport for NSW would be undertaken through the Traffic and Transport Liaison Group to manage potential cumulative construction traffic impacts with M12 Motorway and Elizabeth Drive	Section 5.3.1
T4	Road Safety Audits would be carried out to address vehicular access and egress, and pedestrian, cyclist and public transport safety. Road Safety Audits would be carried out as per the guidelines outlined in Section 10 of the Construction Traffic Management Framework	Section 5.1
T5	Maintain access for pedestrians and cyclists around construction sites as per the guidelines outlined in the Construction Traffic Management Framework. Appropriate signage and line marking would be provided to guide pedestrians and cyclists past construction sites and on the surrounding network to allow access to be maintained	Section 3.2.3
T6	Access for construction vehicles to be planned as per the guidelines outlined in the Construction Traffic Management Framework. Construction site traffic would be managed to minimise movements during peak periods. Vehicle access to and from construction sites would be managed to maintain pedestrian, cyclist and motorist safety	Section 4

Sydney Metro Western Sydney Airport Revised performance outcomes

Revised Performance outcomes - Transport

<p>Network connectivity, safety and efficiency of the transport system in the vicinity of the project are managed to minimise impacts. The safety of transport system customers is maintained . impacts on network capacity and the level of service are effectively managed</p>	<p>Safe and efficient routes are provided for pedestrians, cyclists, and road users at/ near construction sites</p>	<p>Not applicable to the SCAW scope of works</p>
	<p>Access to the existing St Marys Station is maintained while train services are operating</p>	<p>Not applicable to the SCAW scope of works</p>
	<p>Safe access to properties and businesses is maintained during construction, unless alternatives are agreed with property owners and businesses</p>	<p>Section 3.2.4</p>
	<p>Heavy vehicles access the arterial network as soon as practicable on route to, and immediately after leaving a construction site</p>	<p>Section 4.1</p>
	<p>The local community and relevant authorities are informed of transport, access and parking changes/ impacts to minimise inconvenience to the public</p>	<p>Section 5.2.1</p>

Appendix B Briefing paper

Briefing paper

Proposed to be inserted into the latest revision of the CTMP.

Luddenham Road Gate 3 CTMP

Project Name and Scope of Works

- **SM** (Sydney Metro) – Main client of the project
- **SBT** (Station Box and Tunnelling) contractors – Construction of Station Box joining to the Sydney Metro tunnel.
- **SCAW** (Surface Civil and Alignment Works) contractors – Construction of rail formation and Via Ducts from SBT Orchard hills to SBT Badgerys Creek, Stage 1 of Sydney Metro's surface work.

BACKGROUND

The original CTMP was approved in 2022, details of the approved CTMP were:

- Gate 3, situated off Luddenham Road between the two pipelines, was to be used to provide heavy vehicle access and egress from the construction site.
- No works were proposed at the site access point off Luddenham Road
- Heavy vehicles would enter the site via a right hand turn off Luddenham Road and exit via a left turn out only

VERSION 2

- The initial revision of the CTMP (post approval) noted that a piling rig would need to be transported to and from the site on a low loader with the delivery and removal via Luddenham Road
- Changes to the gate and access road at the pipeline's access track and Luddenham Road is required to facilitate the low loader movement.

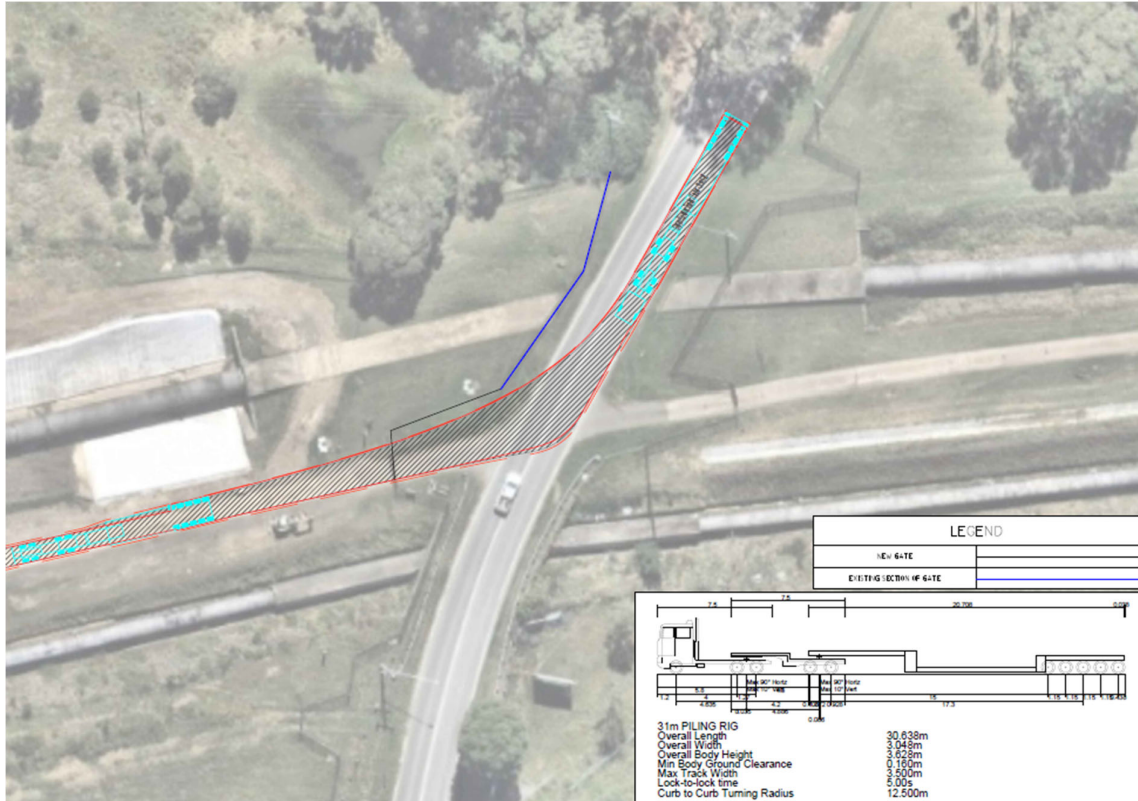

- The works are proposed under a Stop slow arrangement.
- The work will take approximately 1 week to complete.

VERSION 3

- After further investigations it was noted that the low loader would need to reverse out onto Luddenham Road once the piling rig was delivered/ removed as it is not physically possible to turn around the low loader between the two pipelines. The stop slow for the access gate works would be used to facilitate this movement.

VERSION 4

- The next revision was based on a circular route for the piling rig transport. The intent was to bring in the low loader from Luddenham Road (as per the Revision 2) and exit via The Northern Road, thus removing the need to reverse out onto Luddenham Road.
- The works at the access road and gate on Luddenham Road were still required to be undertaken. No works were proposed at The Northern Road as SCAW would be using the driveway previously built by Abergaldie.
- Swept paths were provided for the low loader out onto The Northern Road which showed that a stop would be required to facilitate the left turn movement onto The Northern Road.

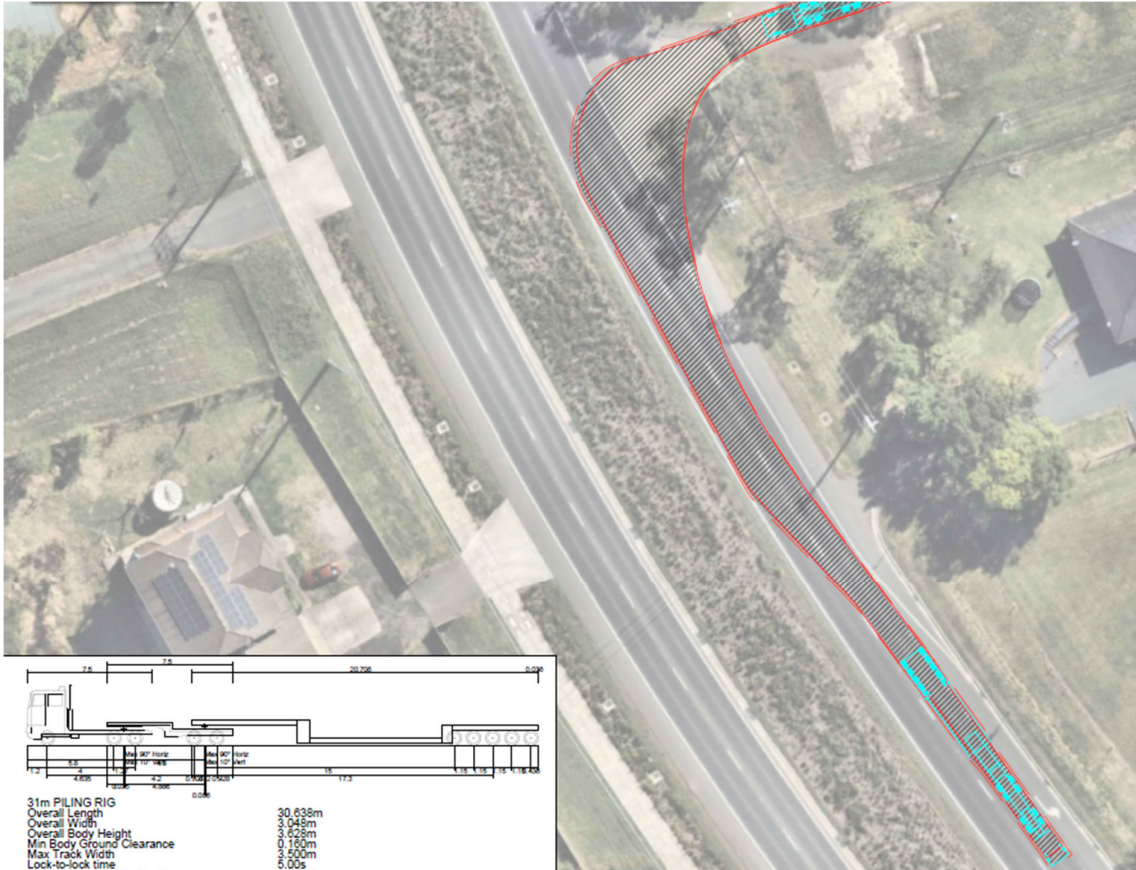

VERSION 5

- After further investigation by the project team, a weight issue along the pipeline access road precluded the removal of the piling rig via The Northern Road, as this section west of the piling rig work site could only facilitate unladen heavy vehicles.
- The CTMP was revised to go back to Version 3 of the CTMP – loaded truck right in from Luddenham Road and empty truck reverses out onto Luddenham Road during mobilization activities, empty truck reverses in from Luddenham Road and loaded truck left out onto Luddenham road during demobilization activities.
- Sydney Metro representatives requested that the CTMP clarify what movements would be occurring out onto The Northern Road and this was included in this revision of the CTMP.

Appendix C Haulage routes

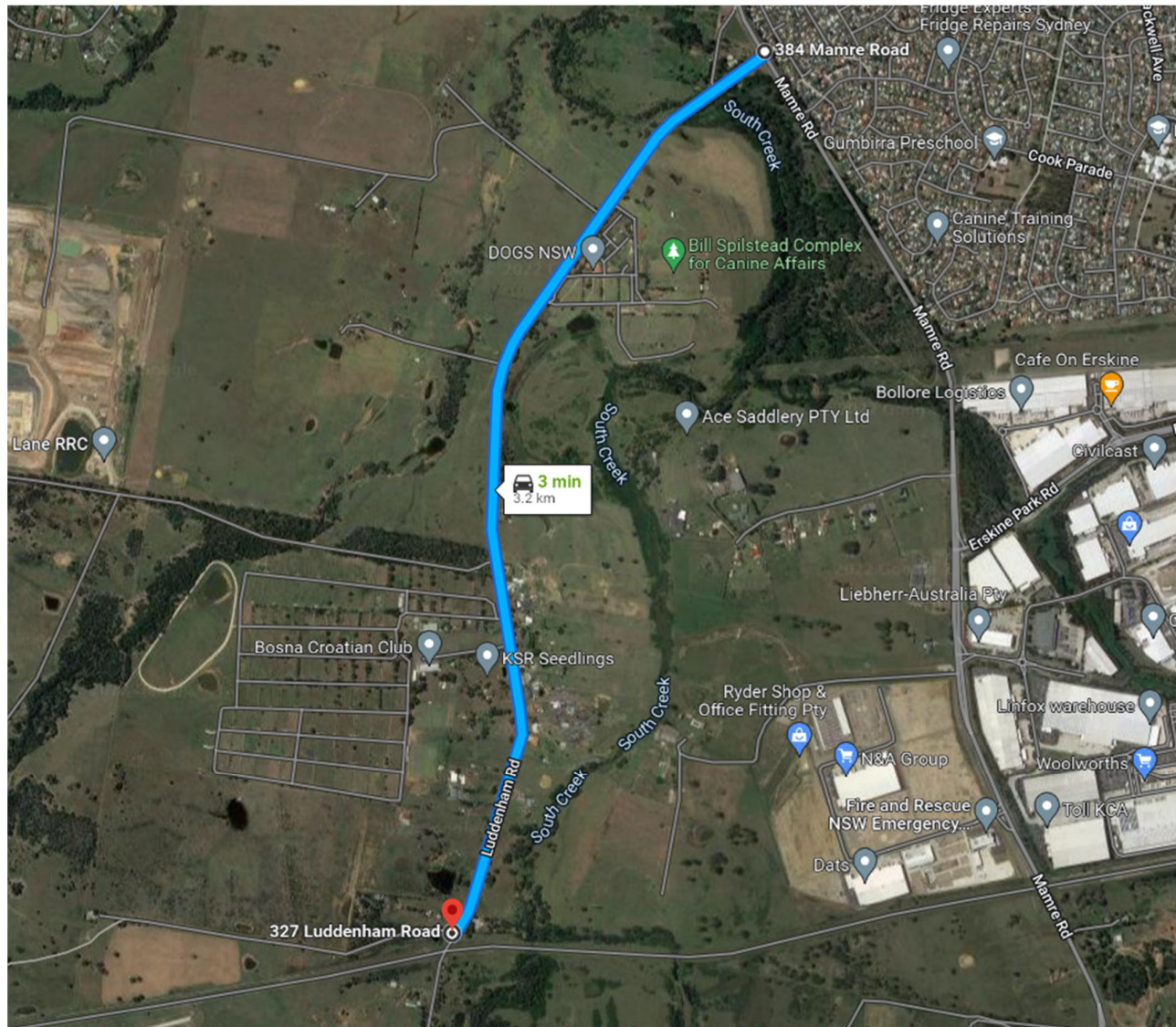

Figure 7: [From the M4 Motorway](#) for access

Appendix D Swept paths

Drawing #	Description
SCAW-LUD-GATE3	Single unit truck into and out of Gate 3
CPBUI-LUD-TGS-0004-00 Sheet 1	Cover sheet
CPBUI-LUD-TGS-0004-00 Sheet 2	Piling rig right turn into site
CPBUI-LUD-TGS-0004-00 Sheet 4	Gate change dimensions
CPBUI-LUD-TGS-0006-00 Sheet 1	Semi-trailer movements at Luddenham Road and The Northern Road



			DRAWN BY:		PROJECT		CLIENT		DRAWING No: SCAW-LUD-GATE3							
			DRW CHECK:						SHEET OF							
			APPROVED:						REVISION							
			IND REVIEW:													
REV	BY	DATE	DESCRIPTION	APPD.	COORDINATE SYSTEM:			HEIGHT DATUM:		SCALE:						
1					1	2	3	4	5	6	7	8	9	10	11	12



SHEET 2 & 3



-	-	-	-	-
-	-	-	-	-
-	-	-	-	-
01	AG	28.06.23	UPDATE EXIT TURN MOVEMENT	LP
00	AG	19.06.23	ORIGINAL ISSUE	AG
REV	BY	DATE	DESCRIPTION	APPD.
COORDINATE SYSTEM:		HEIGHT DATUM:		SCALE:

DRAWN BY:
DRW CHECK:
APPROVED:
IND REVIEW:



WESTERN SYDNEY AIRPORT SURFACE AND CIVIL ALIGNMENT WORKS
LUDDENHAM ROAD SWEEP PATH ASSESSMENTS
31M PILING RIG
LOCALITY PLAN

DRAWING No: CPBUI-LUD-TGS-0003-01
SHEET 1 OF 4
REVISION 00

NOTES

- DIMENSIONS FOR SWEEP PATH ARE ESTIMATED AND THEREFORE APPROXIMATE.

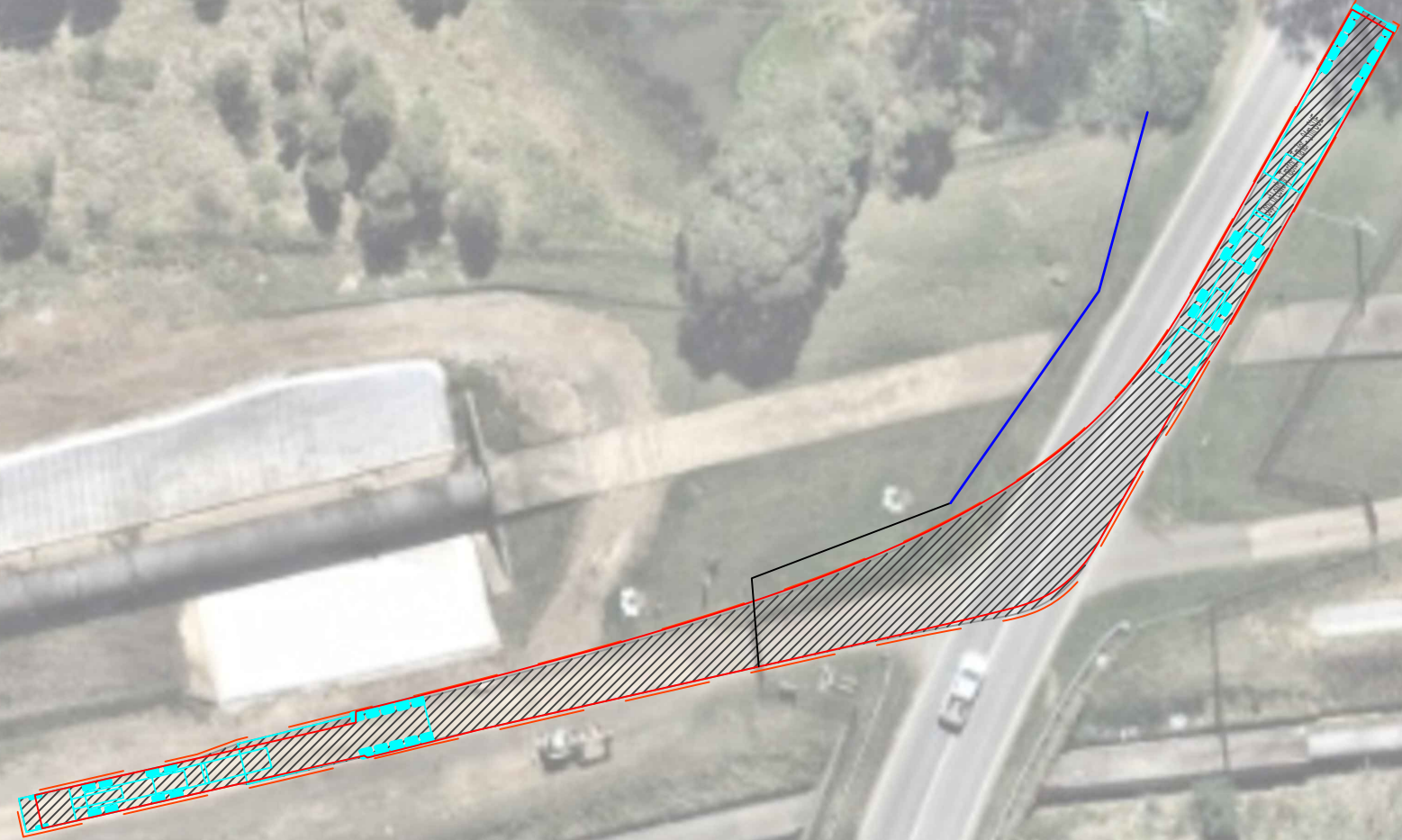

LEGEND	
NEW GATE	
EXISTING SECTION OF GATE	

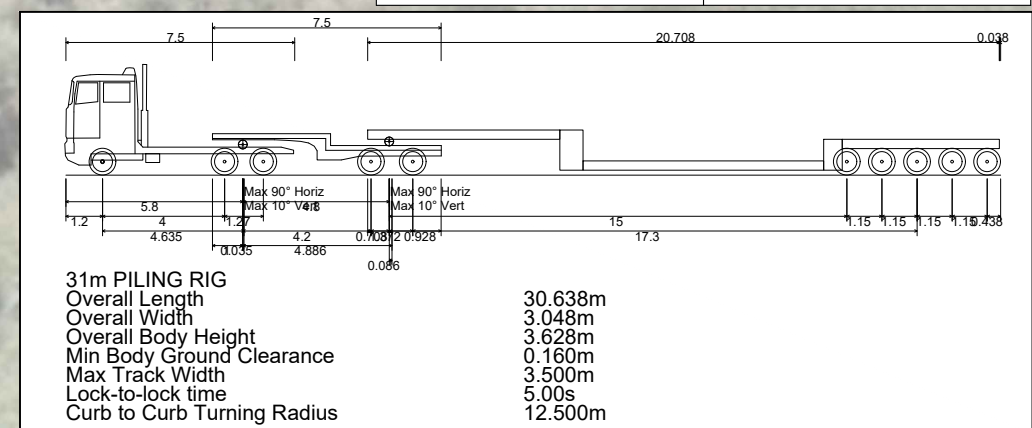

-	-	-	-	-
-	-	-	-	-
-	-	-	-	-
01	AG	28.06.23	UPDATE EXIT TURN MOVEMENT	LP
00	AG	19.06.23	ORIGINAL ISSUE	AG
REV	BY	DATE	DESCRIPTION	APPD.

DRAWN BY:
 DRW CHECK:
 APPROVED:
 IND REVIEW:

CLIENT

WESTERN SYDNEY AIRPORT SURFACE AND CIVIL ALIGNMENT WORKS
LUDDENHAM ROAD SWEEP PATH ASSESSMENTS
31M PILING RIG
SWEEP PATH ASSESSMENT

DRAWING No:	CPBUI-LUD-TGS-0003-01		
SHEET	2	OF	4
REVISION	00		

NOTES
 - DIMENSIONS FOR SWEEP PATH ARE ESTIMATED AND THEREFORE APPROXIMATE.

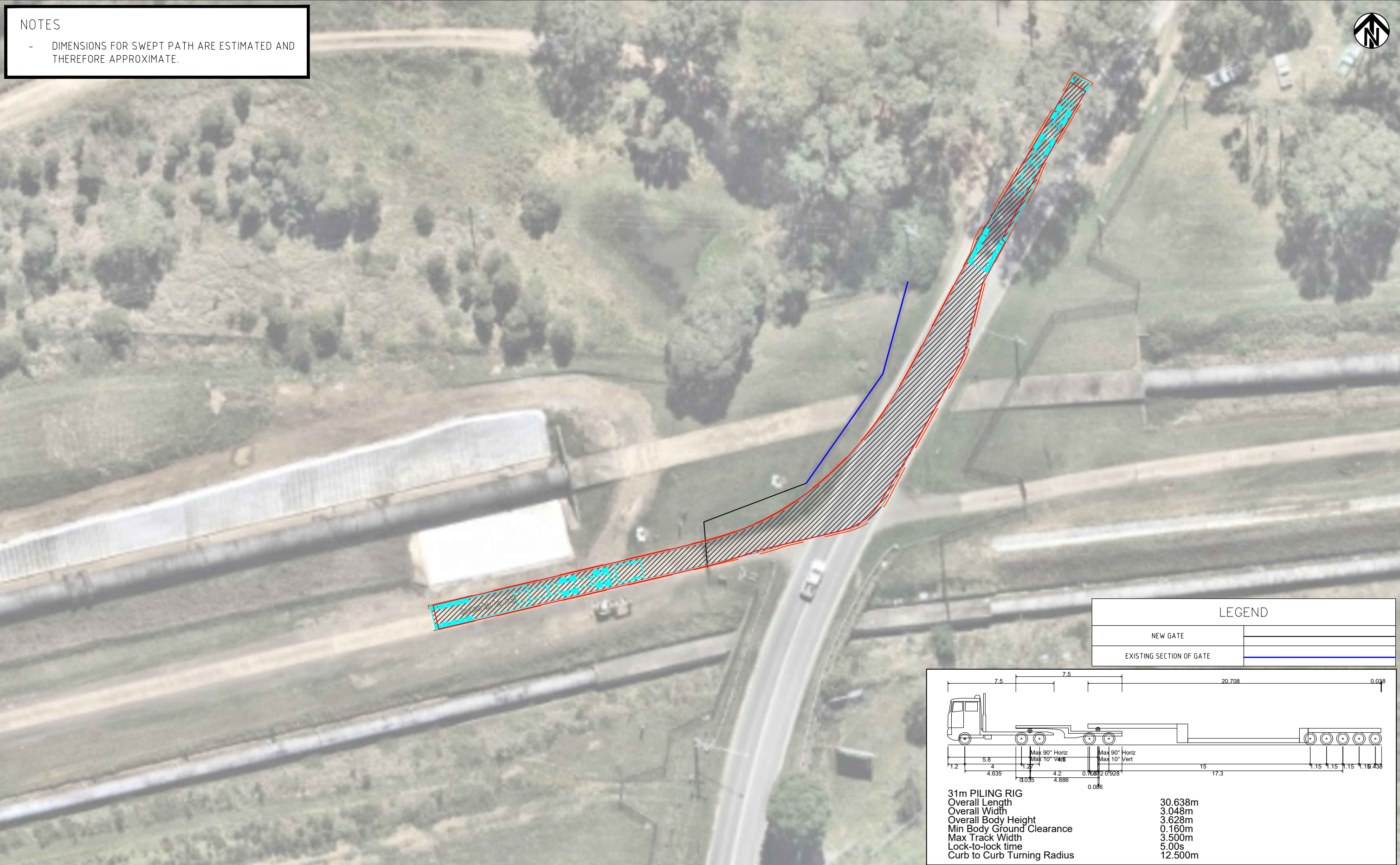

LEGEND	
NEW GATE	
EXISTING SECTION OF GATE	

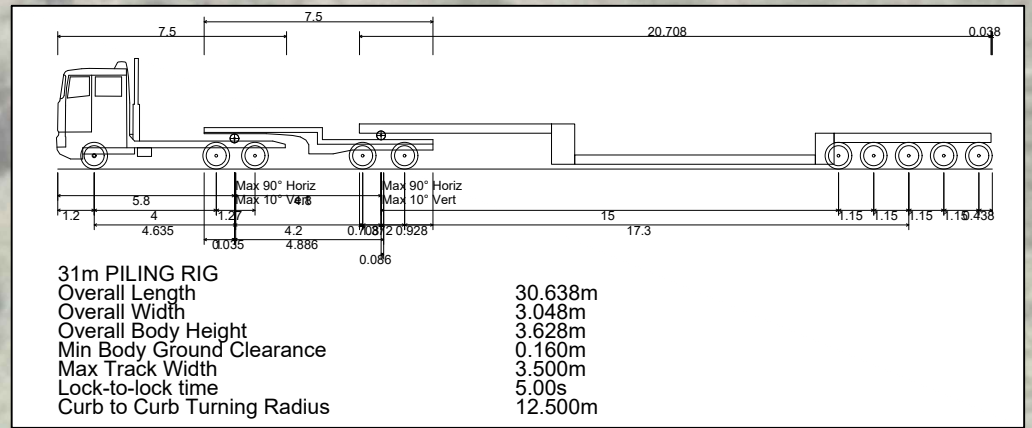

-	-	-	-	-
-	-	-	-	-
-	-	-	-	-
01	AG	28.06.23	UPDATE EXIT TURN MOVEMENT	LP
00	AG	19.06.23	ORIGINAL ISSUE	AG
REV	BY	DATE	DESCRIPTION	APPD.

DRAWN BY: [Redacted]
DRW CHECK: [Redacted]
APPROVED: [Redacted]
IND REVIEW: [Redacted]



CLIENT
 WESTERN SYDNEY AIRPORT SURFACE AND CIVIL ALIGNMENT WORKS
LUDDENHAM ROAD SWEEP PATH ASSESSMENTS
31M PILING RIG
SWEEP PATH ASSESSMENT

DRAWING No:	CPBUI-LUD-TGS-0003-01		
SHEET	3	OF	4
REVISION	00		

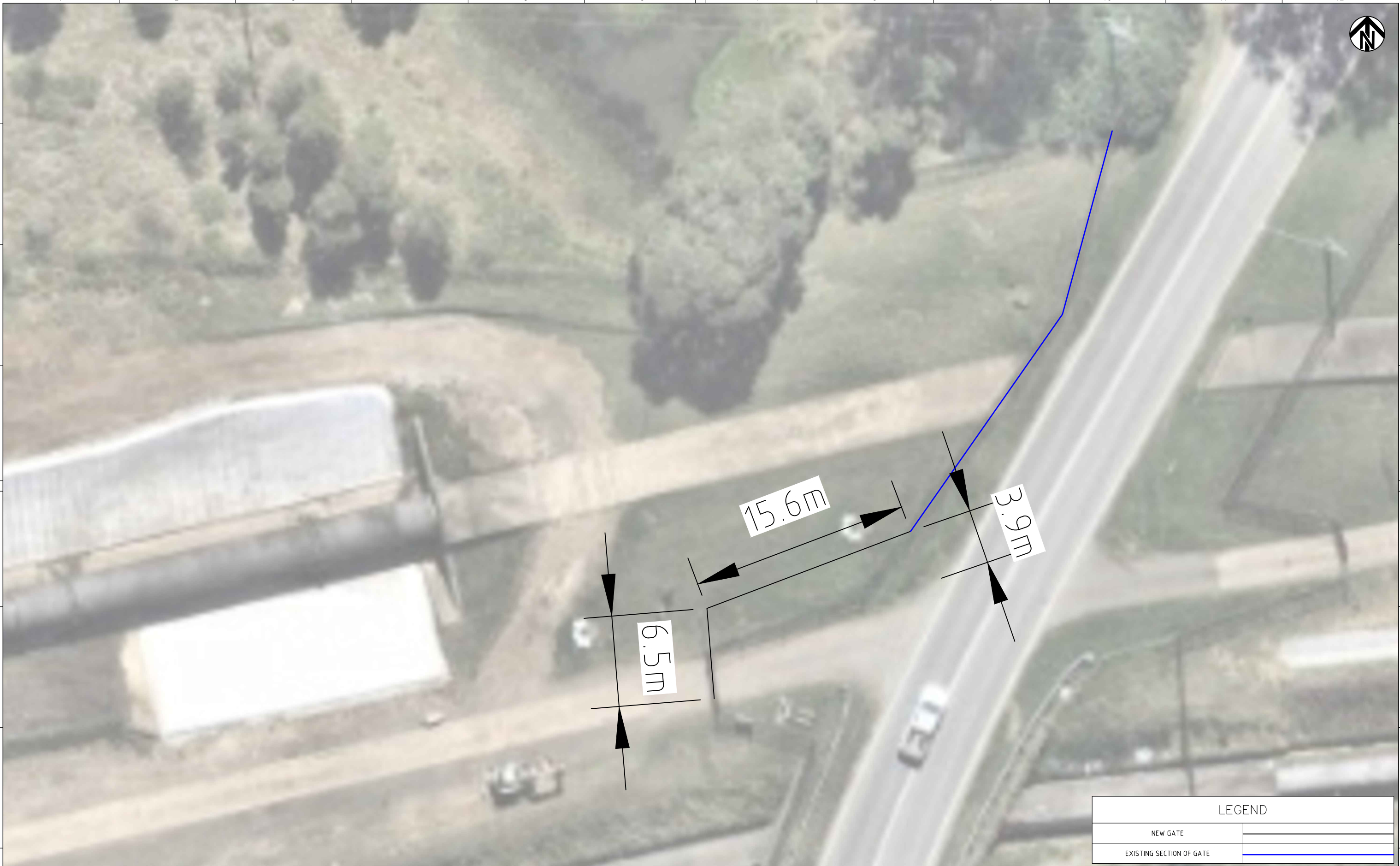

LEGEND	
NEW GATE	
EXISTING SECTION OF GATE	

01	AG	28.06.23	UPDATE EXIT TURN MOVEMENT	LP
00	AG	19.06.23	ORIGINAL ISSUE	AG
REV	BY	DATE	DESCRIPTION	APPD.
COORDINATE SYSTEM:		HEIGHT DATUM:	SCALE:	

DRAWN BY:
 DRW CHECK:
 APPROVED:
 IND REVIEW:



WESTERN SYDNEY AIRPORT SURFACE AND CIVIL ALIGNMENT WORKS
 LUDDENHAM ROAD SWEEP PATH ASSESSMENTS
 31M PILING RIG
 GATE DIMENSIONS

DRAWING No:	CPBUI-LUD-TGS-0003-01		
SHEET	4	OF	4
REVISION	00		

A

B

C

D

E

F

G

H

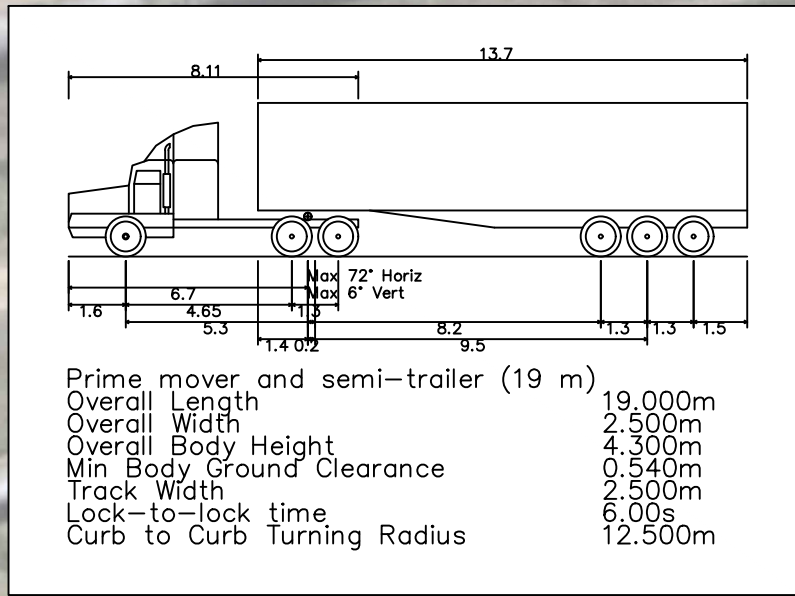
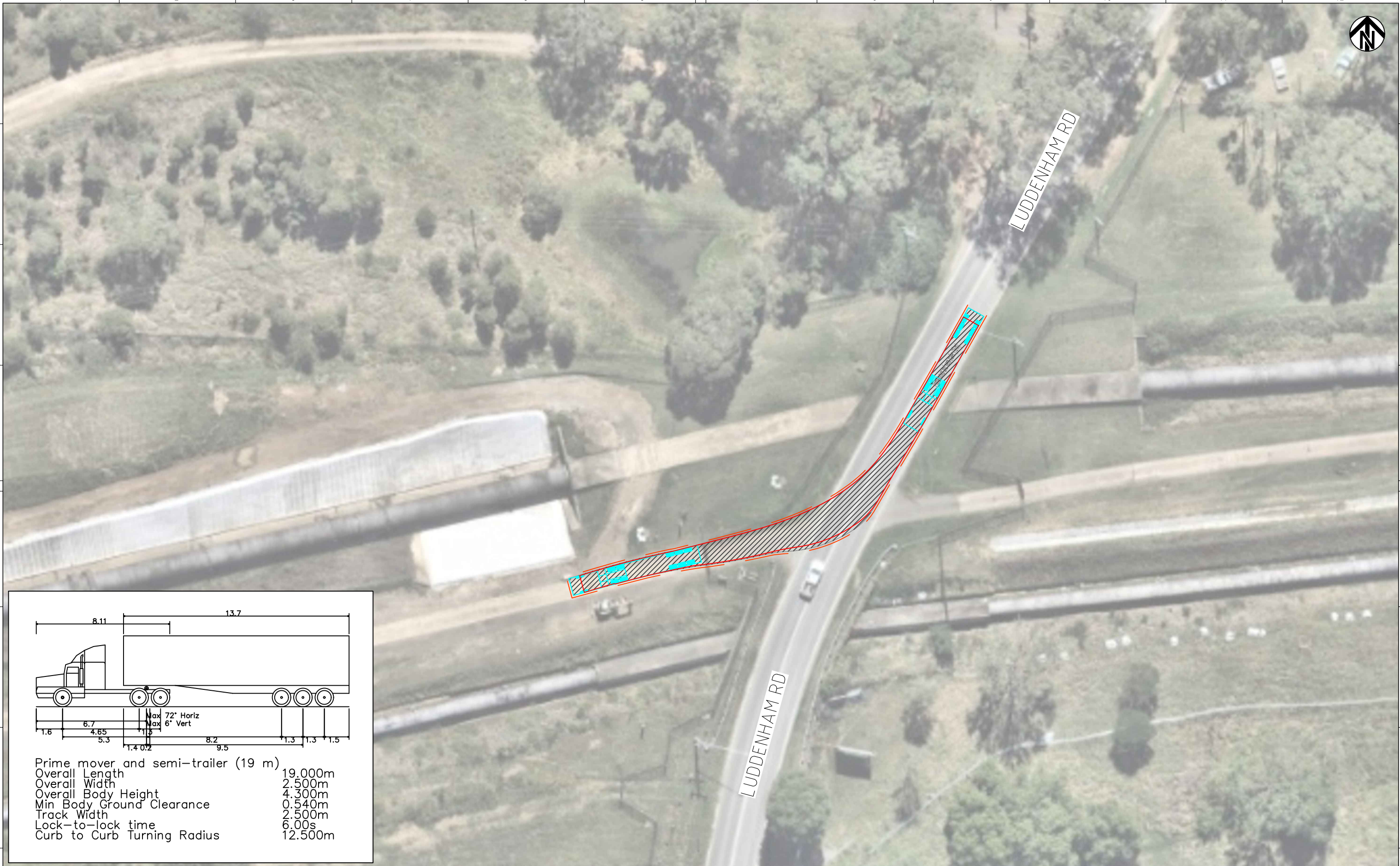

00	AG	27.09.23	ORIGINAL ISSUE	AG
REV	BY	DATE	DESCRIPTION	APPD.
COORDINATE SYSTEM:		HEIGHT DATUM:	SCALE:	

DRAWN BY: [Redacted]

DRW CHECK: [Redacted]

APPROVED: [Redacted]

IND REVIEW: [Redacted]



WESTERN SYDNEY AIRPORT SURFACE AND CIVIL ALIGNMENT WORKS

LUDDENHAM RD AND THE NORTHERN RD
19m SEMI SWEPT PATH ASSESSMENTS
LUDDENHAM RD

DRAWING No:	CPBUI-LUD-TGS-0006-00		
SHEET	1	OF	2
REVISION	00		

A

B

C

D

E

F

G

H

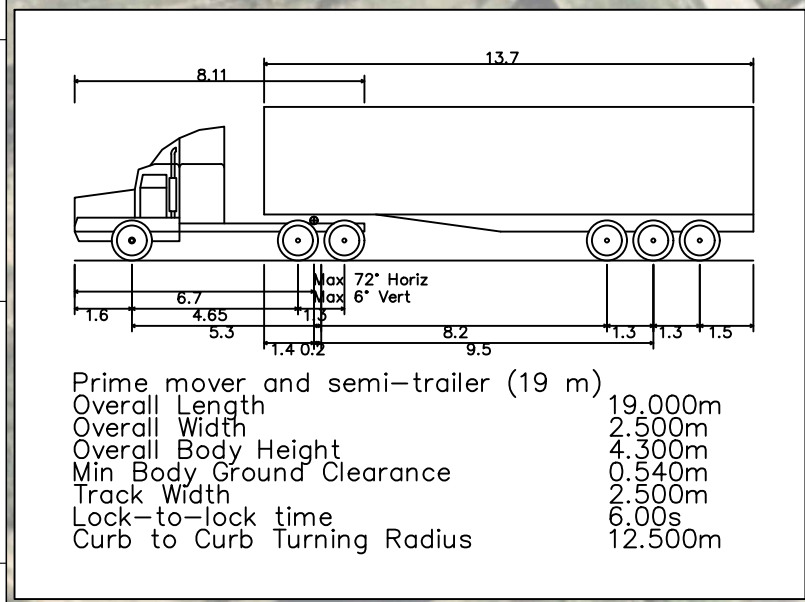
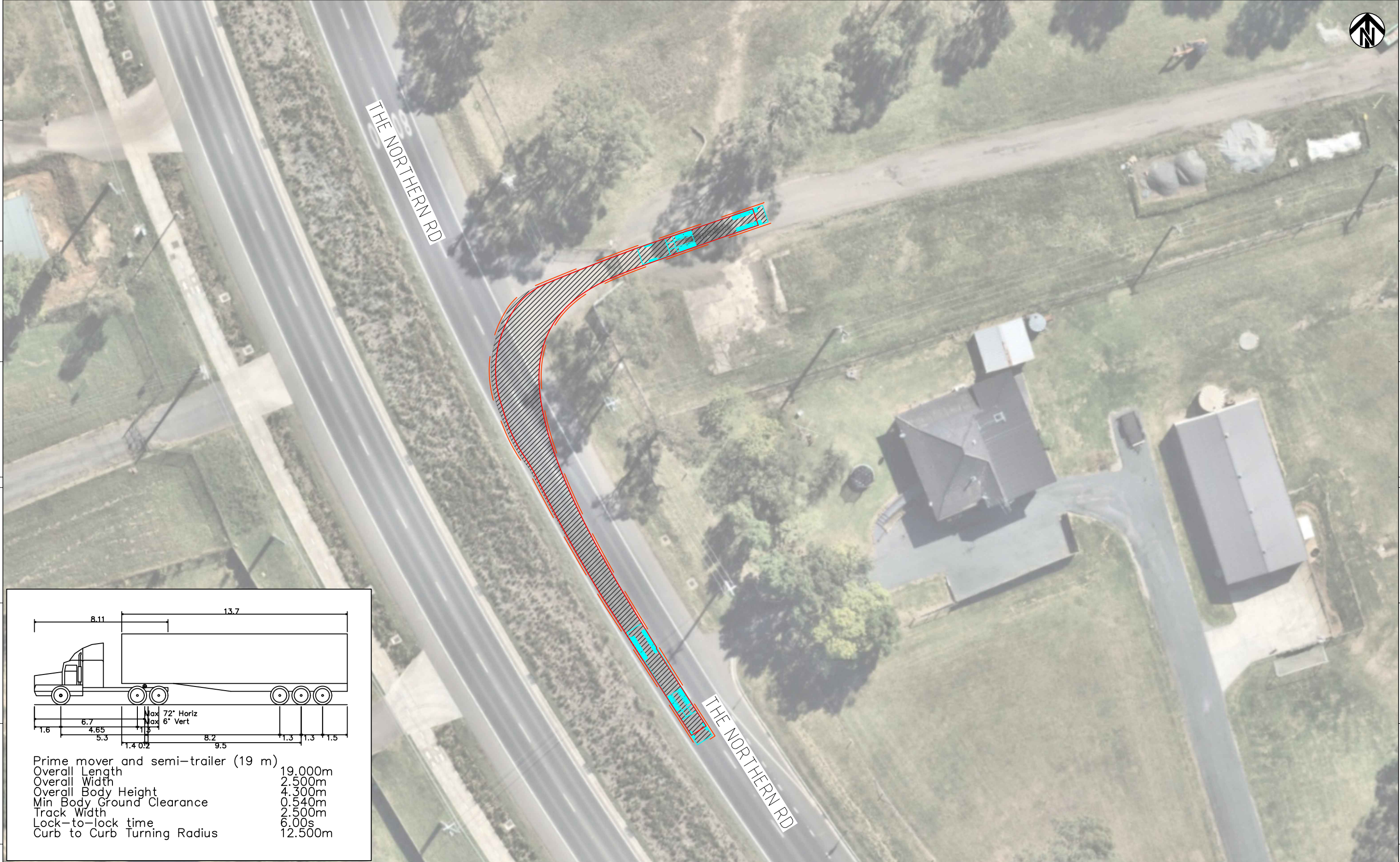

REV	BY	DATE	DESCRIPTION	APPD.
00	AG	27.09.23	ORIGINAL ISSUE	AG
COORDINATE SYSTEM:		HEIGHT DATUM:	SCALE:	

DRAWN BY:	[Redacted]
DRW CHECK:	[Redacted]
APPROVED:	[Redacted]
IND REVIEW:	[Redacted]

CLIENT

WESTERN SYDNEY AIRPORT SURFACE AND CIVIL ALIGNMENT WORKS

LUDDENHAM RD AND THE NORTHERN RD
19m SEMI SWEPT PATH ASSESSMENTS
THE NORTHERN RD

DRAWING No:	CPBUI-LUD-TGS-0006-00		
SHEET	2	OF	2
REVISION	00		

Appendix E Traffic Guidance Scheme

TGS #	Location	From	To	Time	Traffic control	Works	Impacts
CPBUI-LUD-TGS-0004-01 Sheets 1-4	Luddenham Road	Warragamba Pipelines		Day/ night	Stop slow	Access gate changes and piling rig delivery and removal	Minimal impacts as traffic flow maintained

TGS VERIFICATION CHECKLIST

1	Have the below items been addressed on the TGS for this location?	Yes	No
1.1	Traffic Volumes <input checked="" type="checkbox"/> <input type="checkbox"/> Predicted queue length <input checked="" type="checkbox"/> <input type="checkbox"/> Shoulder widths <input checked="" type="checkbox"/> <input type="checkbox"/> Sight distances <input checked="" type="checkbox"/> <input type="checkbox"/> Existing infrastructure <input checked="" type="checkbox"/> <input type="checkbox"/> Transport services (i.e. bus stops) <input checked="" type="checkbox"/> <input type="checkbox"/> Pedestrian generators <input checked="" type="checkbox"/> <input type="checkbox"/> Appropriate site access <input checked="" type="checkbox"/> <input type="checkbox"/> Appropriate escape route for traffic controllers <input checked="" type="checkbox"/> <input type="checkbox"/>		
2	Confirmation	Yes	No
2.1	Does the TGS require adjustments within tolerances? <input type="checkbox"/> <input type="checkbox"/> Does the TGS require any additional modifications? <input type="checkbox"/> <input type="checkbox"/> Is the TGS appropriate for use for works? <input type="checkbox"/> <input type="checkbox"/> Have key risk been addressed on site? <input type="checkbox"/> <input type="checkbox"/>		

Additional comments

RISK ASSESSMENT

3	<input checked="" type="checkbox"/> Does the TGS Involve Detours of traffic?	Yes	No	Risk	Risk rating
3.1	Are Detour routes suitable for all vehicle classes being detoured? <input type="checkbox"/> <input type="checkbox"/> Is access to residential properties and businesses maintained? <input type="checkbox"/> <input type="checkbox"/> Are detour signs located at decision points? <input type="checkbox"/> <input type="checkbox"/> Can roads and intersections used as detour routes accommodate the volumes? <input type="checkbox"/> <input type="checkbox"/> Is the same level of safety maintained for turn movements? <input type="checkbox"/> <input type="checkbox"/>				
4	<input checked="" type="checkbox"/> Does the TGS involve Stop/slow arrangements?	Yes	No	Risk	Risk rating
4.1	Are escape routes defined on the TGS, clear and safe to use? <input checked="" type="checkbox"/> <input type="checkbox"/> Is a PTCO used in place of a Traffic Controller where speed >45kmh? <input checked="" type="checkbox"/> <input type="checkbox"/> Is the speed of the road <=60km/h where TC or PTCO are in use? <input checked="" type="checkbox"/> <input type="checkbox"/> Are 4x traffic cones placed on the edge or centre line, approaching TC or PTCO? <input checked="" type="checkbox"/> <input type="checkbox"/> Is Prepare to stop and Traffic control or PTCO symbolic sign installed? <input checked="" type="checkbox"/> <input type="checkbox"/> Do TC and PTCO positions have adequate lighting during low light conditions? <input checked="" type="checkbox"/> <input type="checkbox"/> Does sight distance of at least 1.5D exist on approach to TC or PTCO? <input checked="" type="checkbox"/> <input type="checkbox"/>				
5	General	Yes	No	Risk	Risk rating
5.1	Does the TGS define minimum clearances required of workers to live traffic? <input checked="" type="checkbox"/> <input type="checkbox"/> Are distances compliant? <input checked="" type="checkbox"/> <input type="checkbox"/> Are worker symbolic signs shown in advance of workers that are visible to traffic? <input checked="" type="checkbox"/> <input type="checkbox"/> Are all signs placed at correct distances? i.e. D for multiple or 2D for single sign? <input checked="" type="checkbox"/> <input type="checkbox"/> Are taper lengths compliant and not placed in areas with poor sight distance? <input checked="" type="checkbox"/> <input type="checkbox"/> Are lane status signs to be placed in advance of a lane merge? <input checked="" type="checkbox"/> <input type="checkbox"/> Are the correct tapers being used? i.e. Merge, Traffic Control, Lateral shift? <input checked="" type="checkbox"/> <input type="checkbox"/> Does the TGS clearly define transition zones between tapers on Multi-lane roads? <input checked="" type="checkbox"/> <input type="checkbox"/> Are they compliant? <input checked="" type="checkbox"/> <input type="checkbox"/> Does the TGS clearly define buffer areas and are they at least 30m in length? <input type="checkbox"/> <input checked="" type="checkbox"/> N/A Does the TGS clearly define site access and egress for work vehicles? <input checked="" type="checkbox"/> <input type="checkbox"/> Are any impacts on traffic managed? <input checked="" type="checkbox"/> <input type="checkbox"/> Does the TGS clearly define pedestrian routes, and are they suitable? <input type="checkbox"/> <input checked="" type="checkbox"/> N/A Does the TGS consider cyclists and can they traverse site safely? <input checked="" type="checkbox"/> <input type="checkbox"/>				

RISK EVALUATION MATRIX

Risk Ratings Very High – VH High – H Medium – M Low – L		Consequence					
		Insignificant C6	Minor C5	Moderate C4	Major C3	Severe C2	Catastrophic C1
Likelihood	Almost certain L1	M	H	H	VH	VH	VH
	Very likely L2	M	M	H	H	VH	VH
	Likely L3	L	M	M	H	H	VH
	Unlikely L4	L	L	M	M	H	H
	Very unlikely L5	L	L	L	M	M	H
	Almost unprecedented L6	L	L	L	L	M	M

RISK MANAGEMENT

* If 'No' selected for any question in items 3, 4 or 5 in the RISK ASSESSMENT above a control needs to be assigned in the table below to mitigate any additional risk. Where blank refer Risk Assessment included as part of TMP.

Item	Control Measures	Residual Risk
5.1	N/A – NO DEFINED PEDESTRIAN ACCESS. BUFFER AREAS NOT NECESSARY AS NO WORKERS ON FOOT	

SIGNED – DESIGNER AND VERIFICATION (PWZTMP OR ITCP)

Name: ...	Date: 25.07.2023 Card No: TCT0002693.(PWZ).....
Name: ...	Date: .../.../..... Card No:.....

REV	BY	DATE	DESCRIPTION	APPD.
01	AG	25.07.22	ADD END ROADWORK SIGNS	AG
00	AG	29.06.23	ORIGINAL ISSUE	AG

DRAWN BY: [Redacted]
 DRW CHECK: [Redacted]
 APPROVED: [Redacted]
 IND REVIEW: [Redacted]

CLIENT

WESTERN SYDNEY AIRPORT SURFACE AND CIVIL ALIGNMENT WORKS

LUDDENHAM ROAD STOP SLOW OPERATION
FOR PILING RIG EGRESS
RISK ASSESSMENT

DRAWING No: CPBUI-LUD-TGS-0004-01

SHEET 1 OF 4

REVISION 00

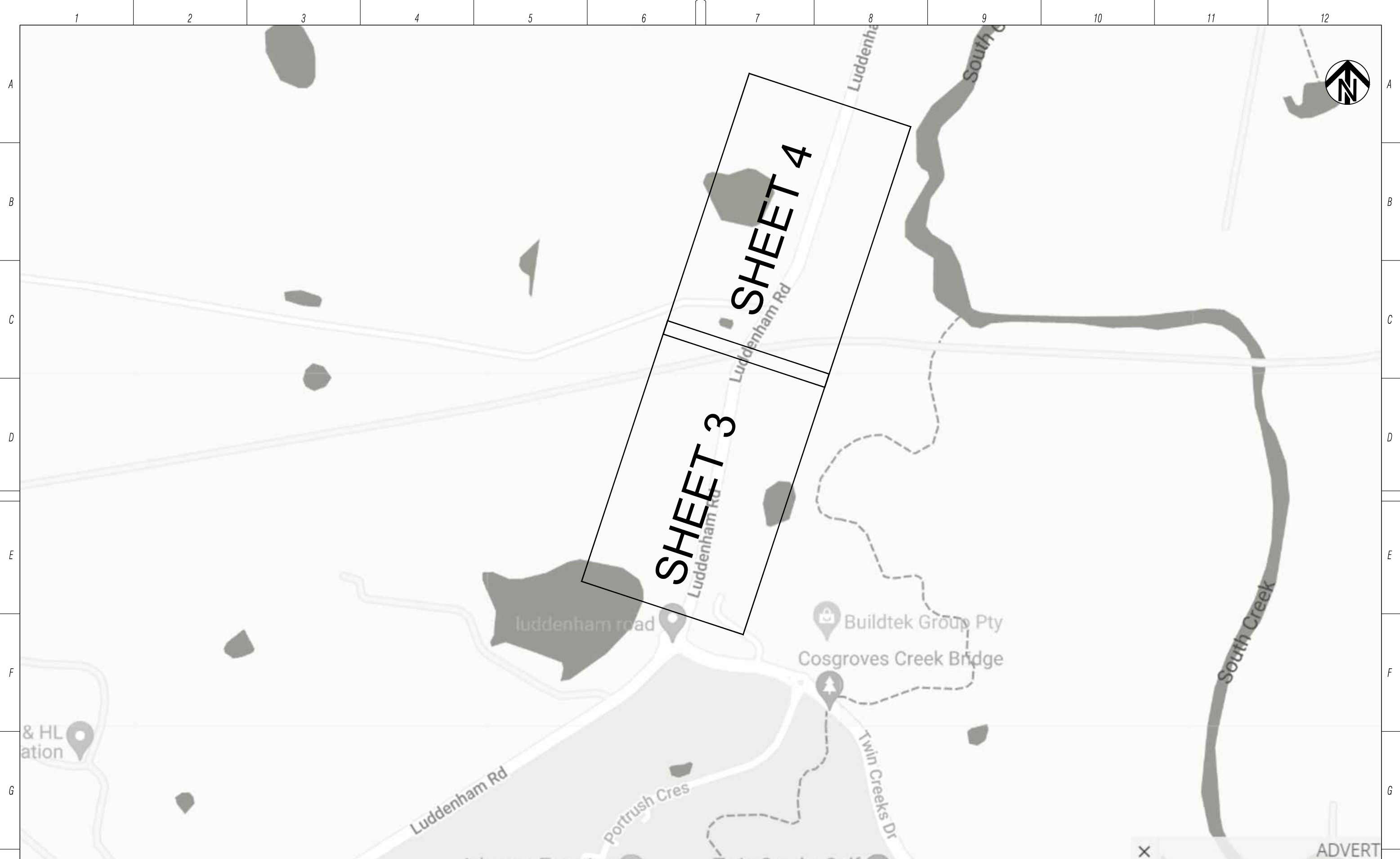

01	AG	25.07.22	ADD END ROADWORK SIGNS	AG
00	AG	29.06.23	ORIGINAL ISSUE	AG
REV	BY	DATE	DESCRIPTION	APPD.
COORDINATE SYSTEM:		HEIGHT DATUM:	SCALE:	

DRAWN BY: [REDACTED]
 DRW CHECK: [REDACTED]
 APPROVED: [REDACTED]
 IND REVIEW: [REDACTED]



CLIENT
 WESTERN SYDNEY AIRPORT SURFACE AND CIVIL ALIGNMENT WORKS
**LUDDENHAM ROAD STOP SLOW OPERATION
 FOR PILING RIG EGRESS
 LOCALITY PLAN**

DRAWING No:		CPBUI-LUD-TGS-0004-01	
SHEET	2	OF	4
REVISION	00		



LEGEND

WORK AREA	
WATER FILLED BARRIER	
TRAFFIC CONTROLLER	
TRAFFIC CONE / BOLLARD	
TEMPORARY SIGN POSITION	d
SITE ACCESS / EGRESS	
KLEMMFIX	

REV	BY	DATE	DESCRIPTION	APPD.
01	AG	25.07.22	ADD END ROADWORK SIGNS	AG
00	AG	29.06.23	ORIGINAL ISSUE	AG

DRAWN BY:	[Redacted]
DRW CHECK:	[Redacted]
APPROVED:	[Redacted]
IND REVIEW:	[Redacted]

CLIENT

WESTERN SYDNEY AIRPORT SURFACE AND CIVIL ALIGNMENT WORKS

**LUDDENHAM ROAD STOP SLOW OPERATION
FOR PILING RIG EGRESS
TRAFFIC GUIDANCE SCHEME**

DRAWING No:	CPBUI-LUD-TGS-0004-01
SHEET	3 OF 4
REVISION	00



REV	BY	DATE	DESCRIPTION	APPD.
01	AG	25.07.22	ADD END ROADWORK SIGNS	AG
00	AG	29.06.23	ORIGINAL ISSUE	AG

DRAWN BY:	[REDACTED]
DRW CHECK:	[REDACTED]
APPROVED:	[REDACTED]
IND REVIEW:	[REDACTED]

CLIENT



WESTERN SYDNEY AIRPORT SURFACE AND CIVIL ALIGNMENT WORKS

**LUDDENHAM ROAD STOP SLOW OPERATION
FOR PILING RIG EGRESS
TRAFFIC GUIDANCE SCHEME**

DRAWING No:	CPBUI-LUD-TGS-0004-01
SHEET	4 OF 4
REVISION	00

Appendix F Road Safety Audit

Road Safety Audit Report

Luddenham Road Gate 3 CTMP

Road/Area	Luddenham Road	Road Safety Audits Reference	RSA-14365
Traffic Stage/Phase	Western Sydney Airport – Surface and Civil Alignment Works	Report Date	5 July 2023
Audit Stage	Desktop Traffic Guidance Scheme	Lead Auditor Second Auditor	
Client		TMP / Drawings	Luddenham Road Gate 3 CTMP, document number SMWSASCA-CPU-1NL-NL000-TF-PLN-000004, Rev D
Client Contact		Report Provider	Road Safety Audits

Desktop TGS General Scope: The scope of the audit is to assess the plans on their merits and in the context of the road environment, with standards and guidelines as a reference. A road safety audit on an earlier version of the CTMP (Rev A) was conducted on 31 October 2022 (RSA Ref: RSA-13302). The responses to the previous audit findings are noted and where they have been effectively closed out, will not be reraised again in this audit report.

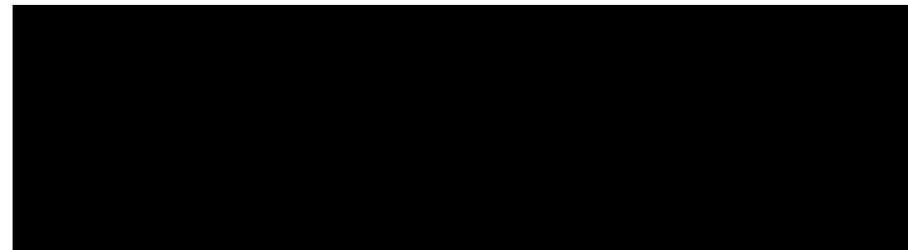
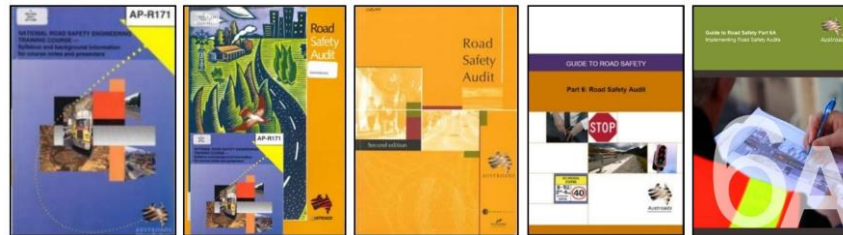

Luddenham Road Gate 3 CTMP Luddenham Road Western Sydney Airport – Surface and Civil Alignment Works

	Audit Point	Treatment Option	[REDACTED]	
			Response	Status
1.	<p>Site Access</p> <p>No safety issues are raised in relation to the sight distance based on the confirmation that adequate SISD and SSD available.</p>	<p>Nil. Note only.</p> <p>Risk: N/A</p>	Noted	Closed
2.	<p>Site Access/Egress – Turning Movement Swept Path</p> <p>The drawing supplied shows that all intended turning movements by the design vehicle can be adequately accommodated. It is noted that the gate will be widened to cater for the turning movement swept path of the piling rig.</p>	<p>Nil. Note only.</p> <p>Risk: N/A</p>	Noted	Closed
3.	<p>Traffic Control</p> <p>The proposed use of traffic control to facilitate access and egress of the piling rig is supported. No safety issues are identified in relation to the proposed TGS as shown in drawing CPBUI-LUD-TGS-0004-00 (2 sheets).</p>	<p>Nil. Note only.</p> <p>Risk: N/A</p>	Noted	Closed

Explanatory Notes

Short Format: This 'short format' report has been pioneered by RSA (Road Safety Audits) since 2008, initiated through requests by clients to assist their processes, for ease with stakeholders, and for timeliness. It is typically confined in use to construction traffic management and typically for discrete packages of plans / areas and often for large projects with repetitious small audit sections. The use of this format assumes that the reader/s know what a road safety audit is and how to respond to it.

Projects: Audit points are often raised in projects in relation to: 1. specific themes (e.g. the use of a safety barrier type), or 2. the treatment of particular locations. Once key issues have been initially raised, they will not necessarily be re-raised in future audits. This will depend on the issue, the RSA's perception of the client's assessment and understanding of the issue, and other factors. Therefore, discrete audits as part of a project should be read and actioned by a **project representative who is familiar with the audit history**.

Responding: Although the client receiving the report does not have to agree to the audit findings/suggestions, the issues and associated risks should be carefully considered. A written response should be made to all of the audit findings raised, then signed off by the responsible person from the project team.

Response: The responder should focus on and consider the **audit point**, regardless of whether the audit team's suggested treatment option is feasible / appropriate / agreed to.

Status: The status of the issue as it sits with the Project. i.e. 'actioned', 'closed', 'pending information / further guidance'.

Risk: Austroads Road Safety Audit Part 6 suggests that the organisation responding to the audit provides a risk assessment. However, RSA will at times offer a guide of 'high' 'medium' and 'low' risk, which is based on a professional appraisal of the risk from severity and frequency and exposure) for the responder to use as a guide. An AGRD6 F10.2 Safe System aligned risk rating can be provided if requested however, safe system-based analysis of risks and treatment options is typically not adopted for traffic management stage audits in the same way as it is in design stage audits.

Language: Other language commonly used and its intent is as follows:

- o 'Urgent': Needs immediate attention / changes as per RSA suggestion or similar.
- o 'Recommend' / 'Serious' / 'Important': Must be robustly reviewed. Most likely requires a change to avoid a high-risk road environment for one or more user groups.
- o 'Should' / 'Suggest' / 'Significant': Based on the view of the RSA team the suggestion should be done, but it concedes that there could be reasons why inaction or alternative action may be preferred. Must be robustly reviewed by contractor and where relevant with key traffic engineering project stakeholders.
- o 'Review' / 'Consider': RSA is raising an observation but has no strong opinion on the outcome and need for changes. Project should review because it's not an immediate and high risk and may not be immediately obvious to RSA the reasons for the practice / setup / behaviour. May need monitoring.
- o 'Minor': Typically, a low road-safety consequence / compliance issues (to guidelines or plans) / administrative controls. Unlikely to increase risk of crash.
- o 'Note': Little or no road safety significance. Typically added to give a complete picture of the design, site, context, analysis, auditors understanding.

Intent of Issues Listing Order: Audit points might be clustered according to location, theme, or time. When this is not done and the audit comprises an uncategorised list of points, the key issues are often discussed first. However, there is no official ordering of points, and they should all be read on their merits and on the basis of the language guide above.

References: 1. Austroads Guide to Road Safety – Part 6 Road Safety Audit – (2022); 2. AS 1742.3 – 2019; 2. State specific codes and guidelines re: Traffic Control at Work Sites; and 3. Design: 1. Austroads guidelines and 2. state-specific supplements and technical publications as relevant.

Safe System: Austroads GRS-RSA6A encourages practitioners to adopt safe system principles within the road safety audit. Safe system (roads) calls for a design to not allow serious injury and fatalities to occur for the expected road users and the typical crash types expected for that design type. This design-objective is considered within this road safety audit as a good practice objective. However, in practice, safe system-based analysis of risks and treatment options is typically not adopted for traffic management stage audits in the same way as it is in design stage audits.

Process and Quality: RSA's quality assurance process is based on its senior auditors having a rich experience base, but also utilises customised checklists designed for niche areas in traffic engineering/road design (e.g. safety barriers, pavement shaping, CBD traffic management), in conjunction with a four-layer audit process: 1. on-site inspection; 2. media and data capture and review; 3. specialist / second auditor input; and (where warranted) 4. secondary blinded reviews.

Audit Coverage: The audit has attempted to balance the safety needs of all road users. As per Austroads guidelines, the suggestions provided have attempted to be realistic/feasible and commensurate with the actual risk posed. Suggestions are made from a safety perspective only, and are made in the absence of full project knowledge and design constraints. RSA can provide a detailed risk assessment / issue evaluation report upon request. The audit raises potential safety risks noted / observed / anticipated by the audit team, and in particular the higher-risk issues. However, a road safety audit is undertaken by people, highly influenced by the experience, views and limitations of the individual team members. It is expected that the project team has competence to identify safety issues itself as the project progresses, and to ask the audit team further questions where necessary.

Road Safety Audit Report

Luddenham Road Gate 3 CTMP

Road/Area	Luddenham Road	Road Safety Audits Reference	RSA-13302
Traffic Stage/Phase	Western Sydney Airport – Surface and Civil Alignment Works	Report Date	31 October 2022
Audit Stage	Desktop Traffic Guidance Scheme	Lead Auditor Second Auditor	[REDACTED]
Client	[REDACTED]	TMP / Drawings	Luddenham Road Gate 3 CTMP, document number SMWSASCA-CPU-1NL-NL000-TF-PLN-000004, Rev A
Client Contact	[REDACTED]	Report Provider	Road Safety Audits

Desktop TGS General Scope: The scope of the audit is to assess the plans on their merits and in the context of the road environment, with standards and guidelines as a reference.

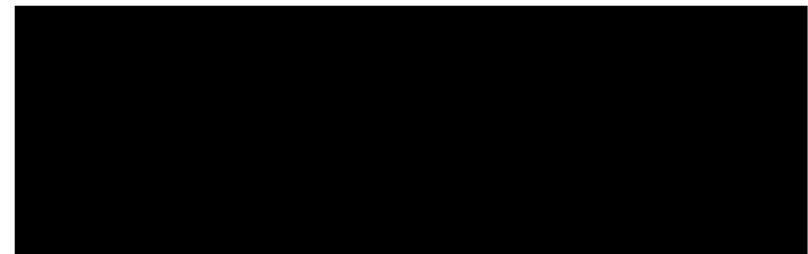
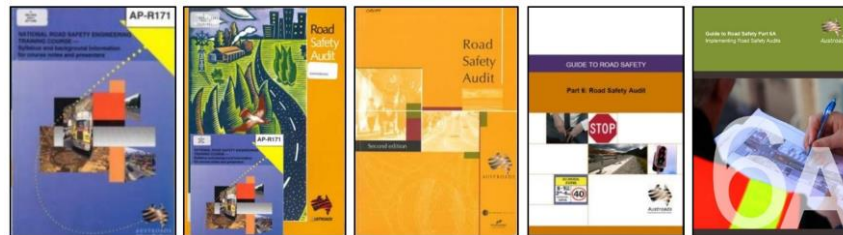

Luddenham Road Gate 3 CTMP Luddenham Road Western Sydney Airport – Surface and Civil Alignment Works

	Audit Point	Treatment Option		
			Response ^x	Status ^y
1.	<p>Site Access</p> <p>It is noted that the proposed site access (Gate 3) is via an existing maintenance access along Luddenham Road. As such it is expected that there would be adequate safe intersection sight distance SISD and stopping sight distance SSD at the subject location for the prevailing posted speed limit.</p>	<p>Confirm that adequate SISD and SSD is available. If required sight distance is not achievable, consideration should be given to reducing the posted speed limit along Luddenham Road during the periods when the subject gate is being used.</p> <p>Risk: N/A</p>	<p>Confirmation from designers notes SISD and SSD are achieved</p>	<p>Closed</p>

Luddenham Road Gate 3 CTMP Luddenham Road Western Sydney Airport – Surface and Civil Alignment Works

	Audit Point	Treatment Option		
			Response ^x	Status ^y
2.	<p>Site Access/Egress</p> <p>It is not obvious from the CTMP, if all turning movements into and of the Gate will be permitted. It is expected that utes and smaller vehicles would be able to undertake all turning movements into and out of the gate. This is why adequate SISD and SSD should be available as discussed in audit point 1.</p> <p>However, based on the lane widths and alignment of Luddenham Road and the access track for Gate 3, and the presence of the guard fence installation, it does not appear possible for articulated vehicles to be able to turn left into the access or right out.</p>	<p>Review and check the swept paths of the expected vehicle types. It is likely that articulated vehicles would have to be restricted to only turn right in and left out of Gate 3.</p> <p>Risk: N/A</p>	<p>Large vehicles will be restricted to right in/left out. It should be noted that there are minimal heavy vehicle numbers at this location</p>	<p>Closed</p>



Explanatory Notes

Short Format: This 'short format' report has been pioneered by RSA (Road Safety Audits) since 2008, initiated through requests by clients to assist their processes, for ease with stakeholders, and for timeliness. It is typically confined in use to construction traffic management and typically for discrete packages of plans / areas and often for large projects with repetitious small audit sections. The use of this format assumes that the reader/s know what a road safety audit is and how to respond to it.

Projects: Audit points are often raised in projects in relation to: 1. specific themes (e.g. the use of a safety barrier type), or 2. the treatment of particular locations. Once key issues have been initially raised, they will not necessarily be re-raised in future audits. This will depend on the issue, the RSA's perception of the client's assessment and understanding of the issue, and other factors. Therefore, discrete audits as part of a project should be read and actioned by a **project representative who is familiar with the audit history**.

Responding: Although the client receiving the report does not have to agree to the audit findings/suggestions, the issues and associated risks should be carefully considered. A written response should be made to all of the audit findings raised, then signed off by the responsible person from the project team.

Response: The responder should focus on and consider the **audit point**, regardless of whether the audit team's suggested treatment option is feasible / appropriate / agreed to.

Status: The status of the issue as it sits with the Project. i.e. 'actioned', 'closed', 'pending information / further guidance'.

Risk: Austroads Road Safety Audit Part 6 suggests that the organisation responding to the audit provides a risk assessment. However, RSA will at times offer a guide of 'high' 'medium' and 'low' risk, which is based on a professional appraisal of the risk from severity and frequency and exposure) for the responder to use as a guide. An AGRD6 F10.2 Safe System aligned risk rating can be provided if requested however, safe system-based analysis of risks and treatment options is typically not adopted for traffic management stage audits in the same way as it is in design stage audits.

Language: Other language commonly used and its intent is as follows:

- o 'Urgent': Needs immediate attention / changes as per RSA suggestion or similar.
- o 'Recommend' / 'Serious' / 'Important': Must be robustly reviewed. Most likely requires a change to avoid a high-risk road environment for one or more user groups.
- o 'Should' / 'Suggest' / 'Significant': Based on the view of the RSA team the suggestion should be done, but it concedes that there could be reasons why inaction or alternative action may be preferred. Must be robustly reviewed by contractor and where relevant with key traffic engineering project stakeholders.
- o 'Review' / 'Consider': RSA is raising an observation but has no strong opinion on the outcome and need for changes. Project should review because it's not an immediate and high risk and may not be immediately obvious to RSA the reasons for the practice / setup / behaviour. May need monitoring.
- o 'Minor': Typically, a low road-safety consequence / compliance issues (to guidelines or plans) / administrative controls. Unlikely to increase risk of crash.
- o 'Note': Little or no road safety significance. Typically added to give a complete picture of the design, site, context, analysis, auditors understanding.

Intent of Issues Listing Order: Audit points might be clustered according to location, theme, or time. When this is not done and the audit comprises an uncategorised list of points, the key issues are often discussed first. However, there is no official ordering of points, and they should all be read on their merits and on the basis of the language guide above.

References: 1. Austroads Guide to Road Safety – Part 6 Road Safety Audit – (2022); 2. AS 1742.3 – 2019; 2. State specific codes and guidelines re: Traffic Control at Work Sites; and 3. Design: 1. Austroads guidelines and 2. state-specific supplements and technical publications as relevant.

Safe System: Austroads GRS-RSA6A encourages practitioners to adopt safe system principles within the road safety audit. Safe system (roads) calls for a design to not allow serious injury and fatalities to occur for the expected road users and the typical crash types expected for that design type. This design-objective is considered within this road safety audit as a good practice objective. However, in practice, safe system-based analysis of risks and treatment options is typically not adopted for traffic management stage audits in the same way as it is in design stage audits.

Process and Quality: RSA's quality assurance process is based on its senior auditors having a rich experience base, but also utilises customised checklists designed for niche areas in traffic engineering/road design (e.g. safety barriers, pavement shaping, CBD traffic management), in conjunction with a four-layer audit process: 1. on-site inspection; 2. media and data capture and review; 3. specialist / second auditor input; and (where warranted) 4. secondary blinded reviews.

Audit Coverage: The audit has attempted to balance the safety needs of all road users. As per Austroads guidelines, the suggestions provided have attempted to be realistic/feasible and commensurate with the actual risk posed. Suggestions are made from a safety perspective only, and are made in the absence of full project knowledge and design constraints. RSA can provide a detailed risk assessment / issue evaluation report upon request. The audit raises potential safety risks noted / observed / anticipated by the audit team, and in particular the higher-risk issues. However, a road safety audit is undertaken by people, highly influenced by the experience, views and limitations of the individual team members. It is expected that the project team has competence to identify safety issues itself as the project progresses, and to ask the audit team further questions where necessary.



Sight Distance Report

Project: 330 Access Road South PKG3-1
Directory: c:\12d\data\AUDC1P12DSYN01\521554 - Metro WSA SCAW Delivery Phase_464957\3 Develop\330 Access Road South PKG3-1.12dmodel
User: MIRE97996
Created: 2022-11-02T11:37:32

Parameters

General

Centreline: ALIGN HAUL ROAD PKG3->MCE0
Ground tin: tin DEM 5M GRID GDA2020
Start chainage: 0.000
End chainage: 285.577
Chainage interval: 10.000
Trial interval: 10.000
Minimum distance: Calculated by safe limit
Maximum distance: 115.000
Assumed safe at ends? true

Eye & Target

Eye height: 1.100
Eye offset: -1.750
Target height: 0.200
Target offset: -1.750

Safe Limit

Speed value: 60
Reaction time: 2.00
Deceleration coefficient: 0.36
Safe distance rounding: 5 (up)

Sight distance forward

CHAINAGE	SIGHT DISTANCE ACHIEVED	SIGHT DISTANCE REQUIRED	STATUS	OBSTRUCTION				
				TYPE	CHAINAGE	OFFSET	HEIGHT	NAME
10.000	110.000	75.000	passed	Object				
20.000	110.000	75.000	passed	Object				
30.000	110.000	75.000	passed	Object				
40.000	110.000	75.000	passed	Object				
50.000	110.000	75.000	passed	Object				
60.000	110.000	75.000	passed	Object				
70.000	110.000	75.000	passed	Object				
80.000	110.000	75.000	passed	Object				
90.000	110.000	75.000	passed	Object				
100.000	110.000	75.000	passed	Object				
110.000	110.000	75.000	passed	Object				
120.000	110.000	75.000	passed	Object				
130.000	110.000	75.000	passed	Object				
140.000	110.000	75.000	passed	Object				
150.000	110.000	75.000	passed	Object				
160.000	110.000	75.000	passed	Object				
170.000	110.000	75.000	passed	Object				
180.000	100.000	75.000	passed	Object				
190.000	90.000	75.000	passed	Object				
200.000	80.000	75.000	passed	Object				
210.000	70.000	75.000	passed	Object				
220.000	60.000	75.000	passed	Object				
230.000	50.000	75.000	passed	Object				
240.000	40.000	75.000	passed	Object				
250.000	30.000	75.000	passed	Object				

CHAINAGE	SIGHT DISTANCE ACHIEVED	SIGHT DISTANCE REQUIRED	STATUS	OBSTRUCTION				
				TYPE	CHAINAGE	OFFSET	HEIGHT	NAME
260.000	20.000	75.000	passed	Object				
270.000	10.000	75.000	passed	Object				

Sight distance reverse

CHAINAGE	SIGHT DISTANCE ACHIEVED	SIGHT DISTANCE REQUIRED	STATUS	OBSTRUCTION				
				TYPE	CHAINAGE	OFFSET	HEIGHT	NAME
280.000	110.000	75.000	passed	Object				
270.000	110.000	75.000	passed	Object				
260.000	110.000	75.000	passed	Object				
250.000	110.000	75.000	passed	Object				
240.000	110.000	75.000	passed	Object				
230.000	110.000	75.000	passed	Object				
220.000	110.000	75.000	passed	Object				
210.000	110.000	75.000	passed	Object				
200.000	110.000	75.000	passed	Object				
190.000	110.000	75.000	passed	Object				
180.000	110.000	75.000	passed	Object				
170.000	110.000	75.000	passed	Object				
160.000	110.000	75.000	passed	Object				
150.000	110.000	75.000	passed	Object				
140.000	110.000	75.000	passed	Object				
130.000	110.000	75.000	passed	Object				
120.000	110.000	75.000	passed	Object				
110.000	110.000	75.000	passed	Object				
100.000	100.000	75.000	passed	Object				
90.000	90.000	75.000	passed	Object				
80.000	80.000	75.000	passed	Object				
70.000	70.000	75.000	passed	Object				
60.000	60.000	75.000	passed	Object				
50.000	50.000	75.000	passed	Object				
40.000	40.000	75.000	passed	Object				
30.000	30.000	75.000	passed	Object				
20.000	20.000	75.000	passed	Object				
10.000	10.000	75.000	passed	Object				

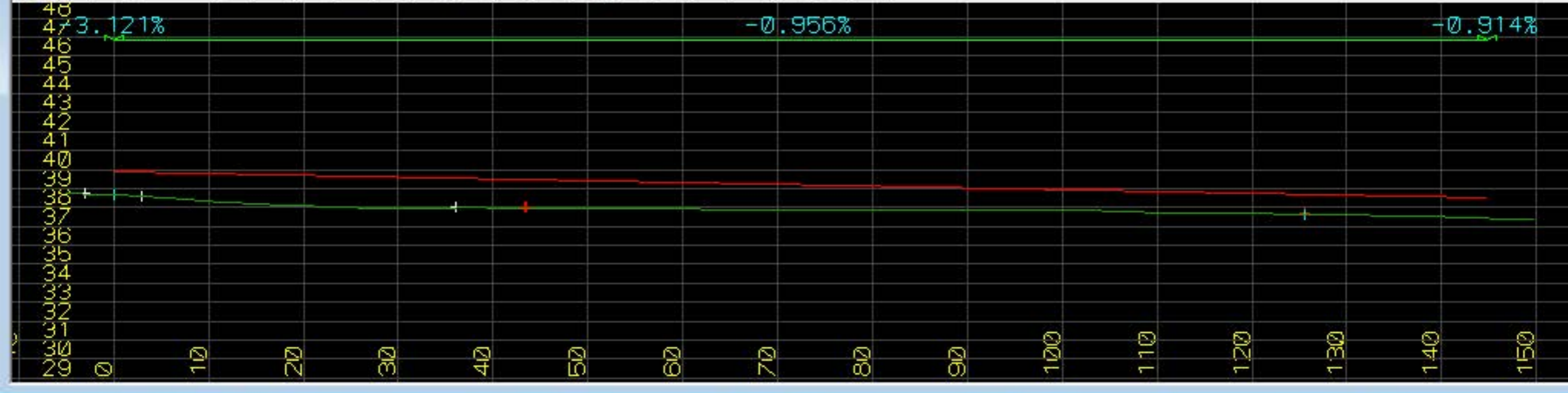



Appendix G Stakeholder comments

NO.	DATE	COMPANY	RAISED BY	REVIEW DOC. NO.*	DOCUMENT REF*	DEED REF*	COMMENTS / RESPONSE	COMMENT CATEGORY*	LINKED ITEM NO	CLOSED OUT
28	11/07/2023	TFN		SMWSASCA-CPU-1NL-NL000-TF-PLN-000004	Appendix C - TGS sheet 2 and 3	NA	Please add "End Roadworks" signage after the roadworks in each direction.	Observation		N
				SMWSASCA-CPU-1NL-NL000-TF-PLN-000004	Appendix C - TGS sheet 2 and 3	NA	Drawings amended	Observation		N
29	12/07/2023	PCC		SMWSASCA-CPU-1NL-NL000-TF-PLN-000004	General	NA	Driveway entry into the pipeline corridor requires widening of the asphalt to safely accommodate the swept paths of vehicles expected in and out of the site. This will maintain the integrity of the road pavement and road reserve by preventing rutting from vehicles and breaks in the edge of the road pavement. The swept paths included in the CTMP show the existing AC driveway is not wide enough to accommodate the swept paths.	Observation		N
				SMWSASCA-CPU-1NL-NL000-TF-PLN-000004	General	NA	Agreed	Observation		N
30	19/07/2023	SMD		SMWSASCA-CPU-1NL-NL000-TF-PLN-000004	3.2.1	N/A	Please provide further clarification on the following statement: "The delivery and removal of the piling rig will require traffic control on Luddenham Road to facilitate the vehicle movements." Please confirm the following: 1. Luddenham Road traffic will be stopped in both directions while the piling rig float enters and exits the site gate. 2. If the piling rig float will always enter and exit the site in a forward direction and if there is room to turn the float around inside the site. 3. If the piling rig float can not be turned around inside the site, explain how the piling rig float will reverse out of the site onto Luddenham Road, providing diagrams to assist the reader understand where necessary. Please provide clearer wording in the document to inform the reader exactly what traffic movements will occur and corresponding traffic control arrangements.	Observation		N
				SMWSASCA-CPU-1NL-NL000-TF-PLN-000004	3.2.1	N/A	1. Both directions of traffic will be stopped 2. There is no room to turnaround the piling rig therefore the rig will enter and exit via Luddenham Road. 3. refer to response to 2	Observation		N
31	19/07/2023	SMD		SMWSASCA-CPU-1NL-NL000-TF-PLN-000004	Appendix C	N/A	Swept paths provided for 31m piling rig float only show the float entering and exiting the site in a forward motion. Please confirm that there is space inside the site for the float to turn around. If there is not room to turn the float around, please provide details and drawings showing how the float will reverse out of site.	Observation		N
				SMWSASCA-CPU-1NL-NL000-TF-PLN-000004	Appendix C	N/A	It is not possible to provide swept paths for reversing movements as AUTOCAD and most swept path software does not allow for this hence why the swept paths have been shown in a forward direction to provide an indication of the area to be used	Observation		N
32	24/07/2023	TFN		SMWSASCA-CPU-1NL-NL000-TF-PLN-000004	General	NA	Changes to an already approved document need to be made explicitly clear for ease of review, and to also limit new comments arising from old information. Suggest updates be covered as an addendum / captured within a new appendix going forward.	Observation		N
				SMWSASCA-CPU-1NL-NL000-TF-PLN-000004	General	NA	Tracked changes are included in the word document which should have been included in the submission - if not they will be provided with this submission	Observation		N

NO.	DATE	COMPANY	RAISED BY	REVIEW DOC. NO.*	DOCUMENT REF*	DEED REF*	COMMENTS / RESPONSE	COMMENT CATEGORY*	LINKED ITEM NO	CLOSED OUT
33	24/07/2023	TFN		SMWSASCA-CPU-1NL-NL000-TF-PLN-000004	3.2.1	NA	It appears that the changes to Gate 3 relate solely to its widening. Is this correct? There is a lot of missing information about what the widening entails. When will this work occur and for how long? What is the expected impact of the widening works? Given the proximity to live traffic, will lane closures be required? How many vehicles are expected for this particular set of works? etc	Observation		N
				SMWSASCA-CPU-1NL-NL000-TF-PLN-000004	3.2.1	NA	The works are the widening works which will be carried out over a week. Stop slow has been provided to allow a clear separation between traffic and the works	Observation		N
34	24/07/2023	TFN		SMWSASCA-CPU-1NL-NL000-TF-PLN-000004	3.2.1	NA	How many piling rig movements are expected?	Observation		N
				SMWSASCA-CPU-1NL-NL000-TF-PLN-000004	3.2.1	NA	1 in and 1 out	Observation		N
35	24/07/2023	TFN		SMWSASCA-CPU-1NL-NL000-TF-PLN-000004	3.2.6	NA	Garde/ EE are working in that exact location and other set ups very close by. There needs to be close coordination because there is a risk that the set ups will start to contradict each other with potential safety implications.	Observation		N
				SMWSASCA-CPU-1NL-NL000-TF-PLN-000004	3.2.6	NA	We coordinate our works on a daily basis with EE and Garde through formalised and informal meetings	Observation		N
36	24/07/2023	TFN		SMWSASCA-CPU-1NL-NL000-TF-PLN-000004	Section 3	-	The CTMP should be more specific for stakeholders' information: 1. Has the construction work been coordinated with Endeavour Energy (EE) to confirm the work program? EE has proposed works at the exact location near the pipeline. 2. Does the construction demand in Table 2 (one HV in & out Gate 3 per peak hour) apply to all phases of construction such as during the construction of substructure and superstructure? 3. Any construction activities require traffic disruptions, stop/slow or lane closure? A specific requirement for a 31m truck ingress and egress is noted. 4. Please advise on the largest access vehicle, except the specific 31m truck requirement. 5. No construction works in May and June based on the following, are these schedules specific? Access and enabling works (Dec-2023); Piling and Substructure (Jan to Apr-2024); Superstructure and Finishing (Jul to Aug-2024).	Potential Non-Compliance		N
				SMWSASCA-CPU-1NL-NL000-TF-PLN-000004	Section 3	-	1. SCAW and EE/ Garde discuss our works on a daily basis 2. Yes the peak hour tables applies to all phases of works - note that this has not changed since the original submission which was previously approved and does not change for the piling rig entry and exit 3. The piling rig entry and exit will require stop slow so yes there is a traffic disruption 4. The largest vehicle requiring access is a 12.5m SU truck and this has not changed since the previously approved CTMP 5. No works are planned between May and June 2024 - note that this has not changed since the previously approved submission	Potential Non-Compliance		N
37	24/07/2023	TFN		SMWSASCA-CPU-1NL-NL000-TF-PLN-000004	(pg. 34 & 35) TGS: CPBUI-LUD-TGS-0004-00		Suggest moving the 40km speed limit signs ahead of the prepare to stop signs in both directions for a safer operation.	Potential Non-Compliance		N

NO.	DATE	COMPANY	RAISED BY	REVIEW DOC. NO.*	DOCUMENT REF*	DEED REF*	COMMENTS / RESPONSE	COMMENT CATEGORY*	LINKED ITEM NO	CLOSED OUT
				SMWSASCA-CPU-1NL-NL000-TF-PLN-000004	(pg. 34 & 35) TGS: CPBUI-LUD-TGS-0004-00		Drawings amended	Potential Non-Compliance		N

CONTRACT NO.	DOCUMENT NO.	TITLE	VER	STATUS	NO.	DATE	COMPANY	RAISED BY	REVIEW DOC. NO.*	DOCUMENT REF*	DEED REF*	COMMENTS / RESPONSE	COMMENT CATEGORY*	LINKED ITEM NO	CLOSED OUT
SCA	SMWSASCA-CPU-1NL-NL000-TF-PLN-000004	Construction Traffic Management Plan - Luddenham Road Gate 3	05.01	S3	41	12/09/2023	SMD		SMWSASCA-CPU-1NL-NL000-TF-PLN-000004	General	CTMF	The absence of track changes makes it difficult to understand what is being sought through this update of the CTMP. Furthermore, the document does not make clear what has changed since the last CTMP approval and the current situation. The Revision table on page i states: "load limit requirements restrict piling rig removal to Luddenham Road gate only". A reader of this document can only guess that this CTMP has been revised for one of the following reasons: 1. to bring the rigs in via this gate ? 2. to widen the gate to accommodate the piling rigs ? 3. to traffic control the piling rig movements into and out of the gate ? 4. for some other unknown reason that has yet to be documented ? Please modify the document with an appropriate explanation of what is being sought through this document revision.	Potential Non-Compliance		Y
									SMWSASCA-CPU-1NL-NL000-TF-PLN-000004	General	CTMF		Potential Non-Compliance		Y
					41.01	28/09/2023	CPU		SMWSASCA-CPU-1NL-NL000-TF-PLN-000004	General	CTMF	Tracked changes word documents are provided to SCAW document controller - I am not sure why this is not provided to the reviewers. I had previously been advised by the document controllers that the pdf was to be a clean copy. However, after discussions with CJP and Sydney Metro I have included tracked changes on the pdfThe original idea for the piling rig access/ egress was in and out via the Luddenham Road gate - then the site team decided that they would bring the piling rig in via Luddenham Road and exit via The Northern Road. However, it would seem that they have encountered issues with the weight of the vehicle when the piling rig is in place so they have had to revert to the original plan for the piling rig via Luddenham Road. The gate wideing on Luddenham Road was included in all versions of the CTMP relating to the piling rig delivery	Potential Non-Compliance		Y
									SMWSASCA-CPU-1NL-NL000-TF-PLN-000004	General	CTMF		Potential Non-Compliance		Y
					42	12/09/2023	SMD		SMWSASCA-CPU-1NL-NL000-TF-PLN-000004	Section 5.3.1	CTMF and General Specifications	Section 5.3.1 - This section fails to note that, contrary to the general specifications and the CTMF, a SCAW representative did not attend the TTLG on 7 September to brief the TTLG on works status including the purpose of this CTMP revision.	Potential Non-Compliance		Y
									SMWSASCA-CPU-1NL-NL000-TF-PLN-000004	Section 5.3.1	CTMF and General Specifications		Potential Non-Compliance		Y
					42.01	28/09/2023	CPU		SMWSASCA-CPU-1NL-NL000-TF-PLN-000004	Section 5.3.1	CTMF and General Specifications	It should be noted that the Traffic Manager asked the site team to attend on this instance - it would seem that they did not	Potential Non-Compliance		Y
									SMWSASCA-CPU-1NL-NL000-TF-PLN-000004	Section 5.3.1	CTMF and General Specifications		Potential Non-Compliance		Y
					43	14/09/2023	SMD		SMWSASCA-CPU-1NL-NL000-TF-PLN-000004	Section 3	N/A	Indicative program is not longer correct. Access and enabling works are now schedules to occur September and October 2023. Piling and Substructure works are scheduled to occur October to December 2023.	Observation		Y
									SMWSASCA-CPU-1NL-NL000-TF-PLN-000004	Section 3	N/A		Observation		Y
					43.01	28/09/2023	CPU		SMWSASCA-CPU-1NL-NL000-TF-PLN-000004	Section 3	N/A	Document amended	Observation		Y
									SMWSASCA-CPU-1NL-NL000-TF-PLN-000004	Section 3	N/A		Observation		Y
					44	14/09/2023	SMD		SMWSASCA-CPU-1NL-NL000-TF-PLN-000004	Section 3.2	N/A	The vehicle movements listed under section 3.2 do not cover all proposed movements accurately. Please clarify that the piling rig float will enter in a forward direction turning right into corridor from Luddenham Road, and exit the corridor by reversing out onto Luddenham Road. Please clarify that semi trailers delivering steel reinforcement cages will enter in a forward direction from Luddenham Road and then proceed along the alignment and exit onto the Northern Road. Please clarify that all other vehicles will enter in a forward direction from Luddenham Road and exit in a forward direction to Luddenham Road.	Observation		Y
									SMWSASCA-CPU-1NL-NL000-TF-PLN-000004	Section 3.2	N/A		Observation		Y

CONTRACT NO.	DOCUMENT NO.	TITLE	VER	STATUS	NO.	DATE	COMPANY	RAISED BY	REVIEW DOC. NO.*	DOCUMENT REF*	DEED REF*	COMMENTS / RESPONSE	COMMENT CATEGORY*	LINKED ITEM NO	CLOSED OUT
					44.01	28/09/2023	CPU		SMWSASCA-CPU-1NL-NL000-TF-PLN-000004	Section 3.2	N/A	Document amended	Observation		Y
									SMWSASCA-CPU-1NL-NL000-TF-PLN-000004	Section 3.2	N/A		Observation		Y
					46	21/09/2023	TFN		SMWSASCA-CPU-1NL-NL000-TF-PLN-000004	1.2	N/A	It is very unclear with in the TMP of what I am expected to be assessing,	Observation		N
									SMWSASCA-CPU-1NL-NL000-TF-PLN-000004	1.2	N/A		Observation		N
					46.01	28/09/2023	CPU		SMWSASCA-CPU-1NL-NL000-TF-PLN-000004	1.2	N/A	Noted - refer to response to Item 41	Observation		N
									SMWSASCA-CPU-1NL-NL000-TF-PLN-000004	1.2	N/A		Observation		N
					46.01.01	6/10/2023	TFN					This document cannot be closed out and should be resubmitted for a proper assessment that was not afforded with the original submission that was hard to differentiate from the previously approved versions of the TMP..	Observation		N
												Refer to revised document including briefing paper and discussions held at TCG 26 October 2023	Observation		N

CONTRACT NO.	DOCUMENT NO.	TITLE	VER	STATUS	NO.	DATE	COMPANY	RAISED BY	REVIEW DOC. NO.*	DOCUMENT REF*	DEED REF*	COMMENTS / RESPONSE	COMMENT CATEGORY*	LINKED ITEM NO	CLOSED OUT	
SCA	SMWSASCA-CPU-1NL-NL000-TF-PLN-000004	Construction Traffic Management Plan - Luddenham Road Gate 3	05.02	S3	46	21/09/2023	TFN	[REDACTED]	SMWSASCA-CPU-1NL-NL000-TF-PLN-000004	1.2	N/A	It is very unclear with in the TMP of what I am expected to be assessing,	Observation		Y	
									SMWSASCA-CPU-1NL-NL000-TF-PLN-000004	1.2	N/A		Observation		Y	
					46.01	28/09/2023	CPU		SMWSASCA-CPU-1NL-NL000-TF-PLN-000004	1.2	N/A		Noted - refer to response to Item 41	Observation		Y
									SMWSASCA-CPU-1NL-NL000-TF-PLN-000004	1.2	N/A		Observation		Y	
					46.01.01	6/10/2023	TFN						This document cannot be closed out and should be resubmitted for a proper assessment that was not afforded with the original submission that was hard to differentiate from the previously approved versions of the TMP..	Observation		Y
													Observation		Y	
					46.01.01.01	31/10/2023	CPU						Refer to revised document including briefing paper and discussions held at TCG 26 October 2023	Observation		Y
													Observation		Y	
					47	3/11/2023	PCC						No Comments			Y
																Y
					48	3/11/2023	TFN			SMWSASCA-CPU-1NL-NL000-TF-PLN-000004	Appendix D Swept Paths	NA	Please consider labelling (or indicating with arrows) the swept path movements as to what is the forward movement and what is a reverse movement. Would also be useful to clarify within the document somewhere if the swept paths are considered the same for the forward and reverse movements for both the right in and left out movements. Thanks.	Observation		N
										SMWSASCA-CPU-1NL-NL000-TF-PLN-000004	Appendix D Swept Paths	NA	There are no reversing movements as the software does not accommodate that as noted in my previous responses to Sydney Metro on this issue	Observation		N
					49	6/11/2023	SMD						No Comments			Y
																Y
					50	16/11/2023	TFN					No Comments			Y	
															Y	

Appendix H Checklists

E.4 Shift / Daily TTM inspection checklist

Shift Inspections must be undertaken by a person holding the PWZTMP or ITCP qualification when a TGS is installed, changed or updated, to ensure the TGS is implemented as designed. This includes at a minimum, twice per shift (recommended every 2 hours). This form can also be used for inspecting 'Aftercare' arrangements.

Completed by:					
Name:		Signature:			
TMP Reference:		TGS Reference:			
Date:		Time/s	Inspection 1	Inspection 2	Inspection 3
			00-00	00-00	00-00
Drive through TGS inspection			Inspection 1	Inspection 2	Inspection 3
Have any adjustments been made to the approved TGS?			<input type="checkbox"/> Yes <input type="checkbox"/> No	<input type="checkbox"/> Yes <input type="checkbox"/> No	<input type="checkbox"/> Yes <input type="checkbox"/> No
If yes, provide details:	Are changes within tolerances? <i>If no, TGS must be reviewed by a PWZTMP</i>	<input type="checkbox"/> Yes <input type="checkbox"/> No	<input type="checkbox"/> Yes <input type="checkbox"/> No	<input type="checkbox"/> Yes <input type="checkbox"/> No	
	Have changes been approved? <i>If no, TGS must be approved</i>	<input type="checkbox"/> Yes <input type="checkbox"/> No	<input type="checkbox"/> Yes <input type="checkbox"/> No	<input type="checkbox"/> Yes <input type="checkbox"/> No	
Comments or details of action taken:					
Have all signs and devices been installed in accordance with approved TGS? <i>If no, provide detail of action taken</i>			<input type="checkbox"/> Yes <input type="checkbox"/> No	<input type="checkbox"/> Yes <input type="checkbox"/> No	<input type="checkbox"/> Yes <input type="checkbox"/> No
Comments or details of action taken:					

Drive through TGS inspection		<i>Inspection 1</i>	<i>Inspection 2</i>	<i>Inspection 3</i>
Are PTCs positioned as prescribed in TGS? <i>If no, provide detail of action taken</i>		<input type="checkbox"/> Yes <input type="checkbox"/> No <input type="checkbox"/> N/A	<input type="checkbox"/> Yes <input type="checkbox"/> No <input type="checkbox"/> N/A	<input type="checkbox"/> Yes <input type="checkbox"/> No <input type="checkbox"/> N/A
Comments or details of action taken:				
Are manual traffic controllers clear of travel lane, have suitable escape route? <i>If no, provide detail and reposition manual traffic controllers</i>		<input type="checkbox"/> Yes <input type="checkbox"/> No <input type="checkbox"/> N/A	<input type="checkbox"/> Yes <input type="checkbox"/> No <input type="checkbox"/> N/A	<input type="checkbox"/> Yes <input type="checkbox"/> No <input type="checkbox"/> N/A
Comments or details of action taken:				
Are sign and devices in good condition, clearly visible to road users? <i>If no, provide detail of action taken</i>		<input type="checkbox"/> Yes <input type="checkbox"/> No	<input type="checkbox"/> Yes <input type="checkbox"/> No	<input type="checkbox"/> Yes <input type="checkbox"/> No
Comments or details of action taken:				
Are all signs mounted level and suitably clear of travel lanes? <i>If no, provide detail of action taken</i>		<input type="checkbox"/> Yes <input type="checkbox"/> No	<input type="checkbox"/> Yes <input type="checkbox"/> No	<input type="checkbox"/> Yes <input type="checkbox"/> No
Comments or details of action taken:				
Are conflicting or non-applicable signs covered or removed? <i>If no, provide detail and remove or cover signs</i>		<input type="checkbox"/> Yes <input type="checkbox"/> No <input type="checkbox"/> N/A	<input type="checkbox"/> Yes <input type="checkbox"/> No <input type="checkbox"/> N/A	<input type="checkbox"/> Yes <input type="checkbox"/> No <input type="checkbox"/> N/A
Comments or details of action taken:				

Drive through TGS inspection		<i>Inspection 1</i>	<i>Inspection 2</i>	<i>Inspection 3</i>
Is temporary delineation installed as prescribed i.e. straight line forming taper?		<input type="checkbox"/> Yes	<input type="checkbox"/> Yes	<input type="checkbox"/> Yes
<i>If no provide details and rectify delineation</i>		<input type="checkbox"/> No	<input type="checkbox"/> No	<input type="checkbox"/> No
Comments or details of action taken:				
Have site conditions changed due to shade, park vehicles, glare etc.		<input type="checkbox"/> Yes	<input type="checkbox"/> Yes	<input type="checkbox"/> Yes
<i>If yes provide details and note if action is required</i>		<input type="checkbox"/> No	<input type="checkbox"/> No	<input type="checkbox"/> No
Comments or details of action taken:				
Are registered trailers i.e. VMS / light towers; suitably clear of travel lanes and delineated?		<input type="checkbox"/> Yes	<input type="checkbox"/> Yes	<input type="checkbox"/> Yes
<i>If no provide details and rectify location</i>		<input type="checkbox"/> No	<input type="checkbox"/> No	<input type="checkbox"/> No
		<input type="checkbox"/> N/A	<input type="checkbox"/> N/A	<input type="checkbox"/> N/A
Comments or details of action taken:				
Are temporary speed zones operating as prescribed?		<input type="checkbox"/> Yes	<input type="checkbox"/> Yes	<input type="checkbox"/> Yes
<i>If no provide details and discuss with work supervisor</i>		<input type="checkbox"/> No	<input type="checkbox"/> No	<input type="checkbox"/> No
		<input type="checkbox"/> N/A	<input type="checkbox"/> N/A	<input type="checkbox"/> N/A
Comments or details of action taken:				
Are workers on foot / plant clearances been applied / observed?		<input type="checkbox"/> Yes	<input type="checkbox"/> Yes	<input type="checkbox"/> Yes
<i>If no provide details and implement controls to rectify</i>		<input type="checkbox"/> No	<input type="checkbox"/> No	<input type="checkbox"/> No
		<input type="checkbox"/> N/A	<input type="checkbox"/> N/A	<input type="checkbox"/> N/A
Comments or details of action taken:				

Post drive through confirmation		<i>Inspection 1</i>	<i>Inspection 2</i>	<i>Inspection 3</i>
Is TGS valid for the site activity and operating safely as intended? <i>If no provide details and implement controls to rectify</i>		<input type="checkbox"/> Yes <input type="checkbox"/> No	<input type="checkbox"/> Yes <input type="checkbox"/> No	<input type="checkbox"/> Yes <input type="checkbox"/> No
Comments or details of action taken:				
Is TGS is appropriate for the current traffic conditions? <i>If no provide details and implement controls to rectify</i>		<input type="checkbox"/> Yes <input type="checkbox"/> No	<input type="checkbox"/> Yes <input type="checkbox"/> No	<input type="checkbox"/> Yes <input type="checkbox"/> No
Comments or details of action taken:				
Have potential hazards identified in TGS been addressed? i.e. end-of-queue management <i>If no provide details of additional hazards and controls required</i>		<input type="checkbox"/> Yes <input type="checkbox"/> No	<input type="checkbox"/> Yes <input type="checkbox"/> No	<input type="checkbox"/> Yes <input type="checkbox"/> No
Comments or details of action taken:				

Additional comments:

E.5 Post completion inspection checklist

Completed by:			
Name:		Road name/Staging Plan number:	
Signature:		Date / time:	
ITCP or PWZTMP card number			
Drive through post completed inspection			
Item		Comments / Action	
Have all work activities been completed?	<input type="checkbox"/> Yes <input type="checkbox"/> No		
Has all plant and equipment been removed?	<input type="checkbox"/> Yes <input type="checkbox"/> No		
Have all TTM signs and devices been removed?	<input type="checkbox"/> Yes <input type="checkbox"/> No		
Has all TTM linemarking been obliterated?	<input type="checkbox"/> Yes <input type="checkbox"/> No		
Have existing permanent speed limits been reinstated?	<input type="checkbox"/> Yes <input type="checkbox"/> No		
Have all TTM site hazards been removed?	<input type="checkbox"/> Yes <input type="checkbox"/> No		
Other	<input type="checkbox"/> Yes <input type="checkbox"/> No		

Desktop post completion inspection		
Have all TGSs for completed tasks been retained?	<input type="checkbox"/> Yes <input type="checkbox"/> No	
Have all TMP required documents been placed in relevant folders?	<input type="checkbox"/> Yes <input type="checkbox"/> No	
Has TMP/TGS designer requested addition information post TTM removal?	<input type="checkbox"/> Yes <input type="checkbox"/> No	
Is the road safe for opening to road users?	<input type="checkbox"/> Yes <input type="checkbox"/> No	

Additional comments:

E.3 Weekly TTM inspection checklist

Weekly inspections must only be carried out by a PWZTMP qualified person. Weekly inspections must be carried out when a site is first open and at least once every week thereafter.

Completed by:			
Name:		Signature:	
TMP Reference:		TGS Reference:	
Date:		Inspection type	<input type="checkbox"/> Pre-opening <input type="checkbox"/> Weekly
Desktop review			
Is a copy of the location TMP and relevant TGS available? <i>If no inspection must not be undertaken until documents are obtained</i>			<input type="checkbox"/> Yes <input type="checkbox"/> No
Details of TMP and TGS:			
Are the location TMP and relevant TGS approved? <i>If no, work must be stopped until documents are approved</i>			<input type="checkbox"/> Yes <input type="checkbox"/> No
Comments or details of action taken:			
Site Inspection			
Inspection completed:	<input type="checkbox"/> During the day <input type="checkbox"/> During the night		
Signs and devices positioned as prescribed and commanding attention? <i>If no provide details and rectify signs</i>			<input type="checkbox"/> Yes <input type="checkbox"/> No
Comments or details of action taken:			

Site Inspection		
Sign sizes as prescribed?		<input type="checkbox"/> Yes <input type="checkbox"/> No
<i>If no provide details and rectify signs</i>		
Comments or details of action taken:		
Signs are mounted level and suitably clear of travel lanes?		<input type="checkbox"/> Yes <input type="checkbox"/> No
<i>If no provide details and rectify signs</i>		
Comments or details of action taken:		
Has temporary delineation been applied as prescribed, with permanent markings obliterated?		<input type="checkbox"/> Yes <input type="checkbox"/> No
<i>If no provide details of action required to rectify delineation</i>		
Comments or details of action taken:		
Are registered trailers i.e. VMS / light towers; suitably clear of travel lanes and delineated?		<input type="checkbox"/> Yes <input type="checkbox"/> No
<i>If no provide details and rectify location</i>		
Comments or details of action taken:		
Are temporary speed zones operating as prescribed?		<input type="checkbox"/> Yes <input type="checkbox"/> No
<i>If no provide details and discuss with work supervisor</i>		
Comments or details of action taken:		
Are PTCD positioned as prescribed in TGS?		<input type="checkbox"/> Yes <input type="checkbox"/> No
<i>If no provide details of action required to rectify</i>		
Comments or details of action taken:		

Site Inspection		
Are manual traffic controllers clear of travel lane, have suitable escape route?		<input type="checkbox"/> Yes <input type="checkbox"/> No
<i>If no provide details of action required to rectify</i>		
Comments or details of action taken:		
Are site accesses and egresses well defined and safe for work vehicles?		<input type="checkbox"/> Yes <input type="checkbox"/> No
<i>If no provide details of action required to rectify</i>		
Comments or details of action taken:		
Termination signs are suitably located? i.e. D downstream of last activity.		<input type="checkbox"/> Yes <input type="checkbox"/> No
<i>If no provide details of action required to rectify</i>		
Comments or details of action taken:		

Post site inspection confirmation	
Is worksite layout operating safely as intended?	<input type="checkbox"/> Yes <input type="checkbox"/> No
<i>If no provide details and implement controls to rectify</i>	
Comments or details of action taken:	
Has TMP identified and addressed key TTM risks?	<input type="checkbox"/> Yes <input type="checkbox"/> No
<i>If no provide details and implement controls to rectify</i>	
Comments or details of action taken:	
Have key TTM risks been addressed on site?	<input type="checkbox"/> Yes <input type="checkbox"/> No
<i>If no provide details of additional hazards and controls required</i>	
Comments or details of action taken:	
Have copies of Shift Inspections been sighted as completed as required?	<input type="checkbox"/> Yes <input type="checkbox"/> No <input type="checkbox"/> N/A
<i>If no provide details and discuss with nominated rep completing Shift Inspections</i>	
Comments or details of action taken:	

Additional comments:

