

F-150

2026 FORD F-150



BUILT FORD TOUGH

For decades, the Ford F-150® has defined what it means to be **“Built Ford Tough.”** As the best-selling pickup for generations, it carries an unmatched legacy of strength, durability, and innovation.

Now, that legacy has arrived in Europe, offering a new standard in capability, comfort, and convenience — ready to tackle any challenge and go anywhere you need to be.



Vehicles may be shown driving on designated off-road terrain, with specifications, features that may vary in availability by market. For complete legal and regulatory information, see disclaimer on the last page.



TOUGH LEADS THE WAY

Built Tough vehicles are constructed to achieve the highest level of performance and offer unmatched capability. Only a few vehicles that meet our legendary standards — passing through the most brutal tests in the harshest conditions on the planet — earn the privilege of being called Built Tough.

BEST-SELLING PICKUP

Launched in 1975, the F-150® is the flagship model of the F-Series, the best-selling pickup line in the United States for 49 years, and also the top-selling vehicle in America for 44 consecutive years.

Now in its 15th generation, the F-150® carries its entire legacy forward with a robust, imposing, and technologically advanced design and extreme capability — proving that Ford is the authority in pickups.



49
YEARS

F-SERIES®
AMERICA'S BEST
SELLING TRUCKS



Up to
3,500 KG

Towing

Up to
772 NM

Torque

Up to
895 KG

Payload

Up to
456 HP

Power



01

PERFORMANCE AND CAPABILITY

From advanced off-road systems and class-leading towing features to intelligent drivetrains and efficient long-range capability.

PAGE 08 - 17

02

INTERIOR COMFORT AND TECHNOLOGY

Premium comfort meets smart tech for a connected, driver-focused experience.

PAGE 18 - 23

03

INNOVATION AND CONVENIENCE

Clever by design and filled with features that simplify your day — on the job or off the grid.

PAGE 24 - 31

04

SAFETY AND DRIVER ASSIST TECHNOLOGY

Confidence is standard. Get to know the advanced systems help keep you aware, in control, and protected.

PAGE 32 - 37

05

MODEL AVAILABILITY

Here's the essential data that makes the F-150 what it is. Explore trims, packages, and options to find your perfect F-150.

PAGE 38 - 57



**WORK HARD.
PLAY HARDER.**

Q1

**PERFORMANCE
& CAPABILITY**



EFFORTLESS CAPABILITY

The F-150's performance story is one of unshakeable toughness and adaptability. Its advanced chassis, cutting-edge powertrains, and intelligent technologies unite to deliver best-in-class towing, surefooted off-road capability, refined on-road comfort, and exceptional efficiency. Every feature here is designed to let you explore further, work harder, and accomplish more.

THE STRENGTH AND POWER YOU NEED

Power

406 HP

Torque

555 NM

5.0L Coyote V8 Engine with 406 hp and 555 Nm of Torque

The iconic V8 engine paired with the 10-speed automatic transmission provides all the strength and power you need — 405 hp and 555 Nm of torque.

Extended Range

Go the extra mile — literally. A finely tuned powertrain, aerodynamic design, and a generous 136-liter fuel tank deliver an impressive range of up to 1,000 km, making long journeys more efficient and fewer stops a reality.



Drive Modes for Every Condition

Up to seven selectable drive modes instantly tailor the F-150's performance to your current environment — whether you're navigating a slippery winter road, tackling a muddy trail, or cruising on the highway — ensuring optimal traction, responsiveness, and efficiency.



Hill Descent Control™

This technology assists the driver in navigating steep descents with greater safety and comfort.



Advanced Aluminum-Alloy Body & Chassis

A lightweight, military-grade aluminum-alloy body sets the F-150 apart. By reducing weight and adding strength, this design improves fuel economy, braking, handling, and payload — all while maintaining the durability that makes it a legend.



LED Headlights with Dynamic Bending

Adjusting to the vehicle's movement, the dynamic bending headlamps significantly improve visibility in curves. Included on F-150 are also features like automatic high beam, daytime running lights, LED taillights, front and rear fog lights, providing a much clearer view.



20" Alloy Wheels with All-Terrain Tires

The 20" alloy wheels come equipped with all-terrain tires, ensuring grip and control on any type of surface.

NO PAVEMENT? PERFECT.



NO TRAIL? NO PROBLEM.

Off-Road Performance with 4×4 Traction

Tackle any terrain with confidence. Choose 4×4 High for dirt roads and rough surfaces, 4×4 Low for extreme off-road conditions, or let Automatic 4×4 (AWD) handle power distribution seamlessly on unpredictable terrain.



Electronic Locking Rear Differential

Engage extra traction at the push of a button. Designed for extreme conditions like deep mud or uneven terrain, this system ensures maximum power to the wheels that need it most — reinforcing the F-150's legendary Built Tough off-road DNA.



Intelligent 4×4 System and Off-Road Capability

An advanced two-speed 4WD system automatically adjusts torque for maximum grip. Combined with an electronic locking rear differential and specialized off-road drive modes, the F-150 is engineered to conquer even the toughest trails.

THE NO.1 OFF-ROAD TRUCK

RAPTOR

F-150 RAPTOR®

The F-150 Raptor® is about more than just speed — it's built to conquer brutal off-road environments. Its capability and durability stem from over a decade of Ford Performance expertise in engineering and torture-testing high-performance trucks. Ford has also upgraded the driveline to ensure the Raptor® handles any challenge with confidence and control.



Off-road driving shown on designated terrain. Full disclaimer on page 59.



RAPTOR

FOX™ shocks with Live Valve™ Technology

The next-generation FOX suspension enables **35.5 cm of front and 38.1 cm of rear** extra-long suspension travel, designed to adapt and provide optimal damping over rough terrain. Meanwhile, the **rear shocks feature a large external oil reservoir**, helping to maintain cooler operating temperatures under demanding conditions.

The **five-link rear setup** incorporates **extra-long trailing arms, a Panhard rod, and 610-mm coil springs—the longest in its class**—delivering exceptional off-road capability while minimizing any loss in towing and payload capacity.

- ✓ **+9 % (15 cm) of track width over F-150 for enhanced vehicle stability**
- ✓ **Unique heavy-duty cast-aluminum upper and lower control arms**
- ✓ **+18 % (5 cm) improved front suspension travel over previous-generation Raptor®**

CONQUER THE TERRAIN



Off-road driving shown on designated terrain. Full disclaimer on page 59.

RAPTOR

Terrain Management System

TMS features 7 driver-selectable preset modes to enhance driving dynamics in a variety of terrains — including Baja and Rock Crawl modes. Combined with Trail Control™ with Trail 1-Pedal Drive, F-150 Raptor® is ready to conquer almost any terrain.

Class-exclusive active valve exhaust

Adjust the sound of your truck with class-exclusive active valve exhaust featuring 4 modes:

- ✓ Quiet
- ✓ Normal
- ✓ Sport
- ✓ Baja

TOUGH. TRIED AND TRUE.



Off-road driving shown on designated terrain. Full disclaimer on page 59.

RAPTOR

Power Delivery

F-150 Raptor® gets power to the BFGoodrich® K02 all-terrain tires via a **2 speed automatic AWD with mechanical locking 4WD and Hi-lock transfer case by TORSEN®**. In addition, the **TORSEN® Front Differential** helps enhance off-road capability by significantly increasing power transfer and grip to the front tires, to help with climbing obstacles or steep inclines.

High-Output Power

The high-output **3.5L EcoBoost® V6 engine** has **456 horsepower** and **691 Nm of torque** and is paired with a 10 speed automatic transmission featuring steering wheel-mounted paddle shifters for SelectShift® capability.

Power
456 HP

Torque
691 NM

02

**INTERIOR COMFORT
AND TECHNOLOGY**

A photograph showing the interior of a Ford F-150. A man wearing a tan cap and a green jacket is driving, and a woman in a blue jacket is in the passenger seat. The car's infotainment screen is visible, displaying various settings like 'Systems Updates', 'Fast Assistant', 'Amazon Alexa', and 'AppLink UpLink'. The background shows a scenic landscape with green hills and a clear sky.

ELEVATE YOUR DRIVING EXPERIENCE

Step inside the F-150 and discover a cockpit designed around you. From advanced digital displays to high-end audio, intuitive connectivity, and indulgent comfort, every detail has been crafted to elevate your driving experience — turning every trip into a first-class journey.



Heated & Ventilated seats

10-way adjustable memory in the driver's seat, adaptable pedals and a heated steering wheel for personalised comfort in any conditions.

Advanced Driver Assistance

Ford Co-pilot360® offers an advanced suite of driver-assist technologies that help keep you safe on the road.

Stay Connected

The F-150 offers a range of advanced technology features, such as SYNC® 4 and Pro Power Onboard™, to keep you connected and powered up while on the go.

Living Room Feel

Premium comfort meets smart convenience. The B&O® Sound System with 14 speakers delivers immersive audio, while thoughtful storage and intuitive tech make every drive feel like home.



**NEXT-LEVEL
COMFORT.
PREMIUM
MATERIALS.
ERGONOMIC
DESIGN.
NEXT-GEN
FEATURES.**



B&O® Unleashed by Bang & Olufsen®

Experience next-level sound with the B&O® Unleashed audio system by Bang & Olufsen®.

14 strategically placed speakers – including a powerful rear subwoofer – deliver rich, crystal-clear audio from every angle. Step inside and turn your cabin into a private concert hall.



Dual Glove Box

Organise your essentials with the help of the additional upper glove compartment.



Head-Up Display

A system that projects essential information onto the windshield using sophisticated technology so that you don't have to take your eyes off the road.



Wireless Phone Charger

Stay connected, effortlessly and charge your phone without the need for cables.



SYNC® 4 with 12" Multifunction Screen

SYNC® 4, Ford's newest multimedia system, comes standard in Europe for the F-150 on a 12" high-resolution screen. This new generation has a processor twice as powerful, is faster, more intuitive, and more customizable.

You can split the screen and control various functions simultaneously, such as navigation, music, and towing, achieving the perfect balance between technology and the convenience of physical buttons.



Wireless Android Auto™ and Apple CarPlay® Connectivity

Interact with your smartphone's apps directly on the central 12" screen. Calls, messages, music, and maps — everything you need to enhance your driving experience.



Built to Last

Premium Comfort ActiveX® is a high-end synthetic seating material designed to fit an active lifestyle. It is easier to clean, resistant to staining, and more durable than leather while maintaining a premium look and feel over time. ActiveX® does not include any animal-based material and is only available on F-150 Lariat®.



12" Digital Instrument Panel

The F-150 is equipped with an impressive 12" digital instrument cluster and drivers display featuring specific animations for each driving mode, selectable information areas, and auxiliary displays for off-road and towing.



360° Camera

The camera set provides a 360° panoramic view. See obstacles not normally in your line of sight in a much more modern and intuitive way on the F-150's 12" center screen.

03

**INNOVATION AND
CONVENIENCE**



ONE TRUCK. ENDLESS POSSIBILITIES.

Beyond performance and comfort lies a world of clever solutions that simplify your day. From illuminating your surroundings to reimagining how you access your cargo, the F-150's innovative features let you work smarter and relax better, wherever you roam. The Ford F-150 brings many smart solutions that provide practicality and comfort to users. The bed now features a side opening that facilitates access, helping to load or unload at the rear.



Lockable Fold-Flat Rear Storage Box

Keep valuable tools, equipment, or personal items locked away and out of sight.

The fold-flat rear storage box transforms your cabin into a secure storage solution.



RIDE IN COMFORT. WORK IN STYLE.

Power-Adjustable seating with Memory

Enjoy 10-way power-adjustable front seats with memory. Thanks to electric adjustments, your onboard experience is more practical and comfortable. The F-150 has memory-enabled power adjustments for seats, pedals, steering wheel (height and depth), and mirrors.

Twin Panel Moonroof

Enjoy an open and spacious feel with the Twin Panel Moonroof. With the push of a button, the front panel can tilt or fully retract, providing customizable airflow for ultimate comfort.

Built-in sunshades help reduce glare and keep the cabin at a comfortable temperature, making every drive more enjoyable.



Interior Work Surface

Use your laptop or enjoy a meal inside the F-150! When parked, the gear shifter can be folded down so you can open a stable work surface.

Turn your F-150 into a mobile office

The innovative interior work surface unfolds from your armrest, creating a stable, flat desk perfect for laptops, tablets, or paperwork — anywhere you park.

BUILT FOR EVERY TASK, EVERY ADVENTURE

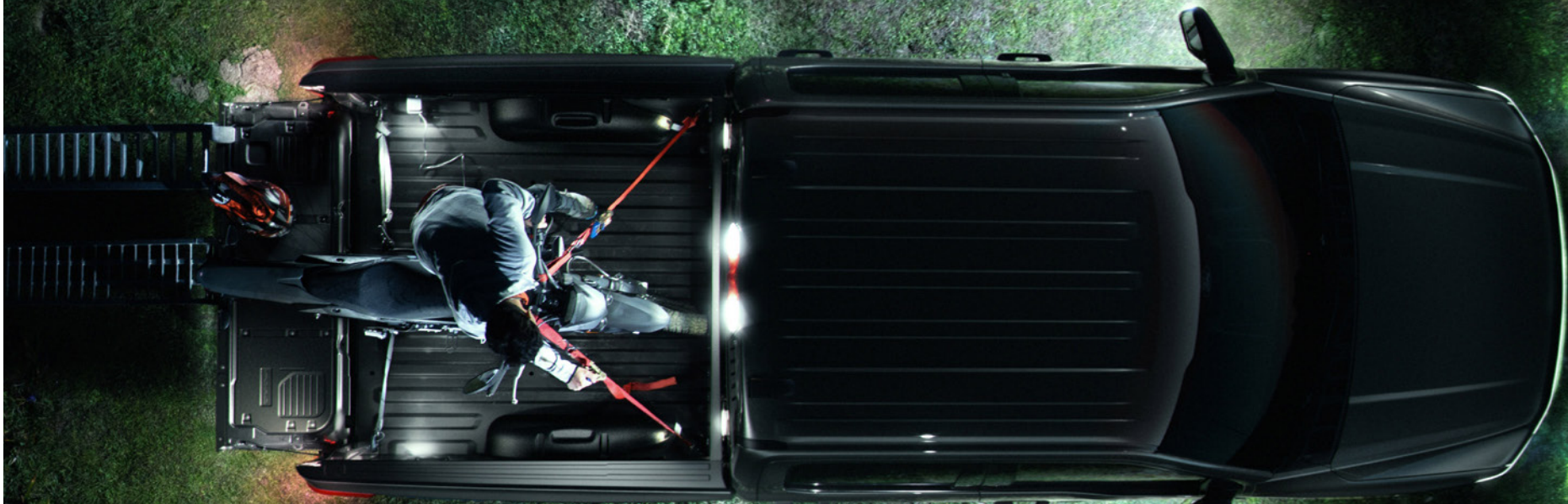

360° Zone Lighting

Flood your surroundings with customizable light at the touch of a button, turning dark campsites, worksites, or driveways into well-lit, productive spaces.



Pro Access Tailgate

The multi-access tailgate offers three opening variations: side, center, and full, making it easier to access or load items in the bed. A tailgate built for convenience.

37°

70°

100°

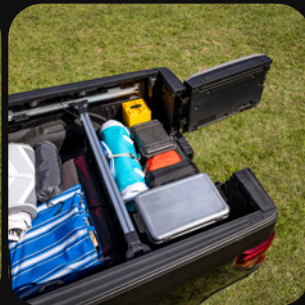

A truck bed designed for real life

The Pro Access Tailgate design provides easier, more ergonomic entry to your bed, so loading, unloading, and securing cargo is a breeze.

Versatility in the Cargo Bed

The Ford F-150's bed is equipped with a spray-in bedliner, an outlet, LED lighting, four pickup box tie-down plates, and anchor hooks. This provides much more versatility and durability so you can use the bed your way.

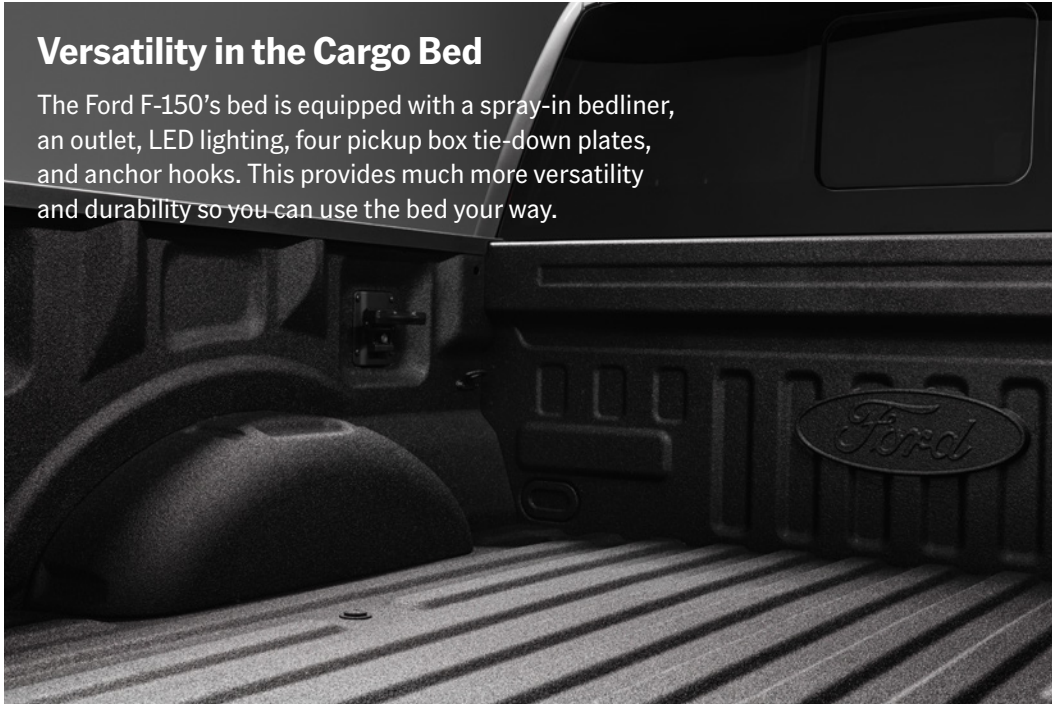

Integrated Box Lighting & Tie-Downs

Integrated box lighting and smart tie-downs help you stay organized, even after sunset. Secure your gear quickly and work confidently, no matter when the job calls.



04

**SAFETY AND DRIVER
ASSIST TECHNOLOGY**



TECH THAT KEEPS YOU IN CONTROL

With Ford Co-pilot360™, confidence is built into every F-150. Advanced sensors, cameras, and driver-assist features work together to help protect you, your passengers, and those around you. These technologies don't just react — they empower you to drive more safely and securely.

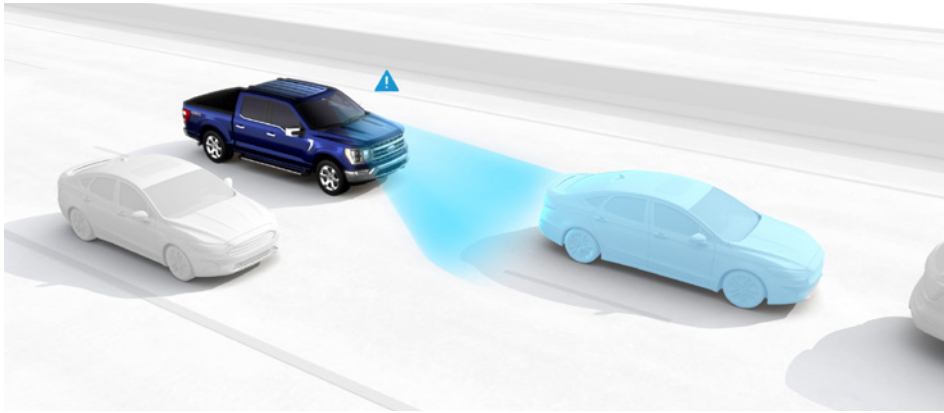

Pre-Collision Assist

Pre-Collision Assist with Automatic Emergency Braking can help detect a potential collision with pedestrians and vehicles ahead. It's designed to help reduce the impact of, and in some cases avoid, a frontal collision. If the system's sensors detect a potential collision with a vehicle or pedestrian ahead, a warning flashes, an alert sounds, and the brakes are applied if needed.



Reverse Brake Assist

Reverse Brake Assist helps sense and alert you to what's behind your vehicle when you're backing up. If it detects the risk of a collision with a pedestrian, vehicle, or shopping cart, it can automatically apply the brakes.

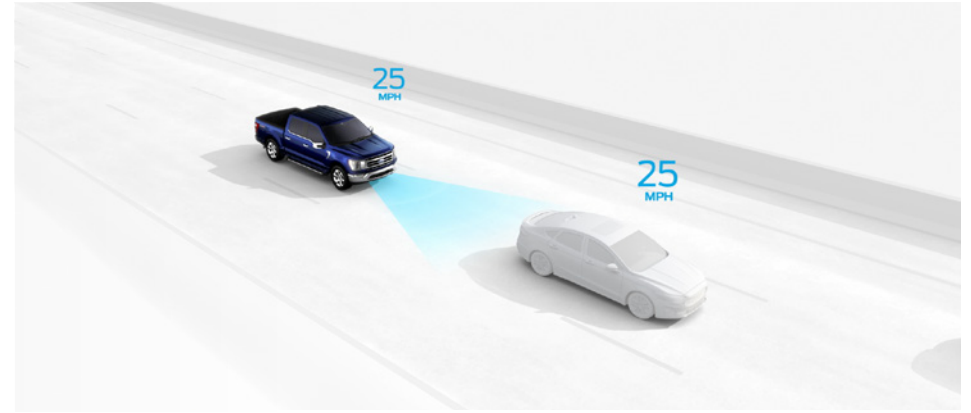

Adaptive Cruise Control With Lane Centering

Adaptive Cruise Control With Stop-and-Go and Lane Centering. Cruise according to your preferences and environment with this available feature. Your vehicle can use cameras and radar to maintain your set distance from the vehicle ahead, even stopping completely if necessary. The smart system will resume your set speed when traffic allows. It can also scan road lines and help keep your vehicle centered in its lane.

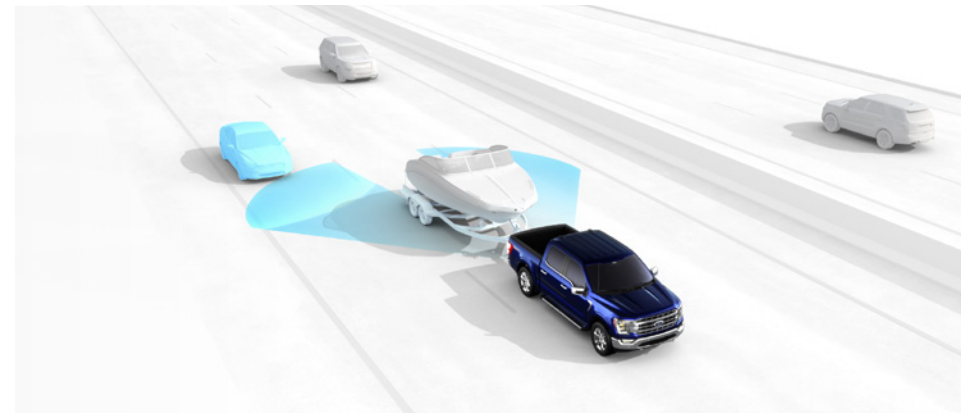

Blind Spot Assist

Blind Spot Assist lets you know if there's a vehicle beside you with a lighted symbol on the side view mirror. In addition to a visual cue, resistive steering torque can help let you know when you are leaving your lane.



SAFETY FOR EVERYONE

8 Airbags

The F-150 is equipped with 8 airbags (two front, two side, two curtain, and knee airbags for the driver and passenger), providing much more safety for everyone on board.



GEARED UP FOR LIFE

360-Degree Camera system

360-Degree Camera system with available front, rear, side and top-down camera, enjoy a clear view of your vehicle's surroundings. You can even view two angles at once with split view display.

Intersection Assist

Intersection Assist help detect potential collisions with oncoming traffic when turning left. Also helps detect a potential collision with pedestrians crossing the vehicle's path.

Exit Warning

Exit Warning uses rear corner radar sensors to help you get out of tricky parking situations, alerting you to unexpected vehicle or cyclists approaching the vehicle's sides from behind and will also alert you when opening the driver or passenger door.



Pro Trailer Hitch Assist™

Get hitched on your own. This available feature uses the rear sensors to align the trailer's hitch with the ball, controlling the steering, gas, and brakes on a reverse path to get the job done.



Trailer reverse guidance

This available feature is designed to help improve visibility while maneuvering trailers in reverse. It uses the 360-degree camera system to automatically select the angle that provides the best visibility based on the direction of the trailer.













Pro Trailer Backup Assist™

Take your hands off the wheel and steer your trailer using the control knob for added convenience and awareness. The available system takes the guesswork out of maneuvering a trailer in reverse.

05

**MODEL
AVAILABILITY**

Exterior Colours

	XLT	LARIAT®	RAPTOR®
 Agate Black Metallic	•	•	•
 Argon Blue Metallic	•	-	-
 Avalanche	•	•	•
 Carbonized Gray Metallic	•	•	•
 Iconic Silver Metallic	•	•	-
 Marsh Gray	•	-	-
 Oxford White	•	•	•
 Ruby Red Metallic Tinted Clearcoat	•	•	•
 Antimatter Blue Metallic	-	-	•
 Star White Metallic Tri-Coat	-	•	-
 Shelter Green Metallic	-	-	•

SuperCrew® 5.5-ft box for XLT and Lariat®

Length: 5,893 mm / Width: 2,029 mm / Height: 1,958 mm

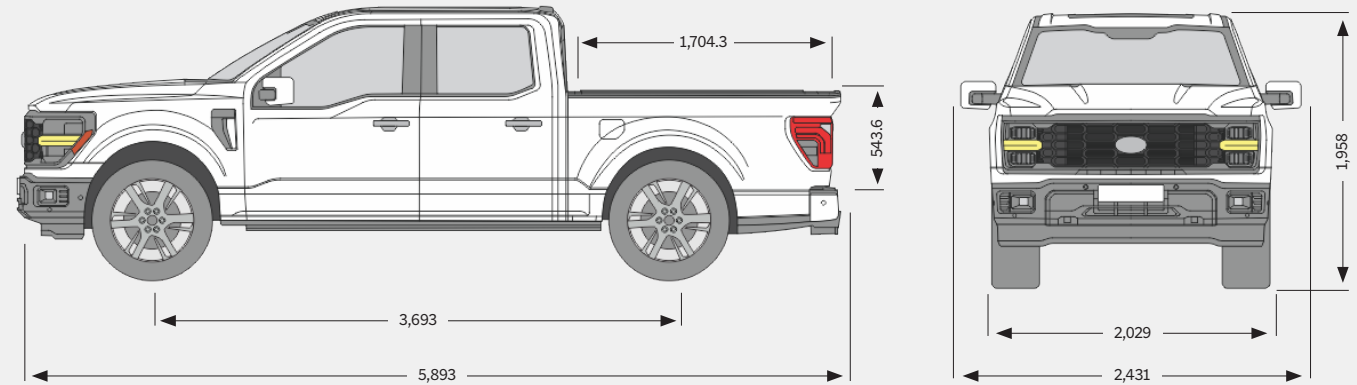

SuperCrew® 5.5-ft box w/ 35" tire for Raptor®

Length: 5,908 mm / Width: 2,200 mm / Height: 2,027 mm

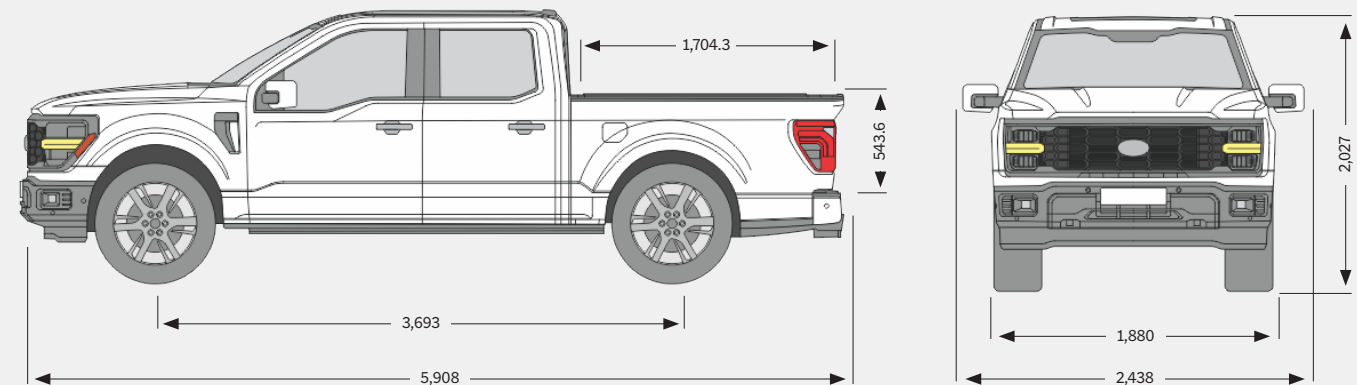

F-150 LARIAT

Up to
3,500 KG
Towing

Up to
895 KG
Payload

Up to
772 NM
Torque

Up to
436 HP
Power



F-150 LARIAT® 5.0L V8

Engine
5.0L V8 406HP

Horsepower
406 Hp

Fuel Consumption
14.36 L/100 km

Torque
555 Nm

CO2 Emission
342 g/km



F-150 LARIAT® 3.5L FHEV

Engine
3.5L PowerBoost
Full Hybrid 436HP

Horsepower
436 Hp

Fuel Consumption
10.16 L/100 km

Torque
772 Nm

CO2 Emission
242 g/km

KEY HIGHLIGHTS LARIAT

Technical Highlights

- Head-Up Display
- 360-degree Camera with Front and Rear Parking Sensors
- B&O® Unleashed by Bang & Olufsen® (14 Speakers incl. Subwoofer)
- Remote Start System with Remote Tailgate Release
- Adaptive Cruise Control
- 136 L Extended Fuel Tank
- 4×4 Two-Speed Torque-on-Demand Transfer Case with Flat Tow Mode
- Intelligent Access with Push-Button Start (incl. Approach Detection)
- Pro Trailer Back-up Assist™ with Hitch Assist™
- Power Inverter – 2.4 kW Power-to-the-Box

Interior Highlights

- 12" Digital Drivers Display and SYNC® 4 Infotainment
- 10-way Power Driver w/ Memory and 8-way Power Front Passenger Seat
- Heated and Ventilated Front Seats
- Second-Row Heated Seats
- Under-seat, lockable, fold-flat storage with partitions
- Wireless Apple CarPlay® and Android Auto™
- Navigation Center
- Twin Panel Moonroof (43V)
- Dual-zone Electronic Automatic Temperature Control
- Wireless Charger
- Interior Work Surface with Stowable Shifter
- Heated Steering Wheel
- Power-Sliding Rear-Window with Privacy Tint and Defrost

Exterior Highlights

- Pro Access Tailgate
- Black Appearance Package
- FX4® Off-Road Package (195)
- Dual Exhaust with Black Tips
- 20" Black Aluminum Wheels
- Power Tailgate
- 6" Extended Running Boards
- LED Projector with Dynamic Bending Headlamps
- 360-degree Zone Lighting with Additional Box Lights
- Four Pickup Box Tie-Down Plates
- Bedliner Tough Bed® Spray-in (96W)
- Bed Storage Box
- Wheel Well Liner (96L)

INCLUDED PACKAGES LARIAT

Packages refer to factory-installed equipment groups and option packages that come pre-configured with the vehicle. They enhance the vehicle beyond its standard features, adding additional functionality, styling, or performance upgrades as specified in the list below.

Equipment Group – High (502A)

6" Extended Running Boards

Second-Row Heated Seats

Head-Up Display

B&O® Unleashed Sound System by Bang & Olufsen®
(14 Speakers including Subwoofer)

Mobile Office Package

LED Projector with Dynamic Bending Headlamps

Heated and Ventilated Front Seats

Remote Start System with Remote Tailgate Release

Adaptive Cruise Control

10-way Power Driver and 8-way Power
Front Passenger Seat

Twin Panel Moonroof (43V)

Wheel Well Liner (96L)

Bedliner Tough Bed® Spray-In (96W)

Mobile Office Package (50M)

Interior Work Surface

Flowthrough Console – Vinyl Lid

Under Seat Storage

Partitioned Lockable Fold-Flat Storage

Onboard 400 W Outlet

Wireless Charger

Black Appearance Package (195)

20" Six-spoke Black Alloy Wheels

Dual Exhaust with BlackTips

Black Onyx Interior Trim Color

Exterior Mirror Finish – Body-Color

Bumper – Front – Painted Body-Color

FX4® Off-Road Package (55A)

Floor Mats – Tray-style All-Weather Rubber Mats Front/Rear
(Less Carpet Mats)

Bed Decal – FX4®

Premium Off-Road-Tuned Front/Rear Shock Absorbers

3.73 Final Drive Ratio w/ Electronic Locking Differential

Axle Size – 9.75"

Hill Descent Control™

Skid Plates

Bed Utility Package (68L)

Pro Access Tailgate

Power Tailgate

Box Light

Four Pickup Box Tie-Down Plates

EXTERIOR HIGHLIGHTS LARIAT

Remote Start System
with Tailgate Release

Twin Panel
Moonroof

360-degree Zone
Lighting with Additional
Box Lights



Dual Front
Recovery Hooks

Protective underbody
Skid Plates

Dual Exhaust
with Black Tips

Premium Off-Road-Tuned
Front and Rear Shock Absorbers



LED Projector with Dynamic Bending Headlamps

20" Black aluminum wheels fitted with all terrain tires

Active Front Air dam for improved aerodynamics



360-degree Camera with Front and Rear Parking Sensors

Bedliner Tough Bed® Spray-in

6" Extended Running Boards

Pro Access Tailgate for easier bed access

F-150 RAPTOR

3,500 KG
Max towing

646 KG
Max payload

691 NM
Torque

456 HP
Power





F-150 RAPTOR® 3.5L HIGH-OUTPUT ECOBOOST

Engine

3.5L High-Output
EcoBoost® 456 HP

Fuel Consumption

16.44 L/100 km

Horsepower

456 Hp

CO2 Emission

293 g/km

Torque

691 Nm

KEY HIGHLIGHTS RAPTOR

Technical Highlights

- Head-Up Display
- 360-degree camera with front and rear parking sensors
- B&O® Unleashed by Bang & Olufsen® (14 Speakers including Subwoofer)
- Remote Start System with Remote Tailgate Release
- Adaptive Cruise Control
- 136 L Extended Range Fuel Tank
- 2-Speed Torque-On-Demand 4x4 with Mechanical Locking transfer case
- Intelligent Access with Push-Button Start (incl. Approach Detection)
- Pro Trailer Back-up Assist™ with Hitch Assist™
- Pro Power Onboard™ – 2 kW
- Trail Control™ with Trail 1-Pedal Drive and Trail Turn Assist
- Terrain Management System with seven modes: Normal, Sport, Tow/Haul, Slippery, Rock Crawl, Off-Road, Baja

Interior Highlights

- 12" Digital Drivers display and SYNC 4 infotainment
- 10-way Power Driver w/ Memory and 8-way Power Front Passenger Seat
- Heated and Ventilated Front Seats
- Second-Row Heated Seats
- Under-seat, lockable, fold-flat storage with partitions
- Wireless Apple CarPlay® and Android Auto™
- Navigation Center
- Twin Panel Moonroof (43V)
- Dual-zone Electronic Automatic Temperature Control
- Wireless Charger
- Interior Work Surface with Stowable Shifter
- Heated Unique Sport Leather Wrapped Steering Wheel

Exterior Highlights

- Tailgate Appliqué "FORD"
- Flared Front Fenders, Flared Pickup Box Outers and Hood w/Air Extractors
- Unique Long Travel Suspension Set-up
- Dual Exhaust with Black Tips
- 17" Cast Aluminum Wheels with 35" Tires
- Power Tailgate (incl. Tailgate Step and Tailgate Work Surface)
- Cast-Aluminum Running Boards
- LED Projector with Dynamic Bending Headlamps
- 360-degree Zone lighting with Additional Box Lights
- Four Pickup Box Tie-Down Plates
- Bedliner Tough Bed® Spray-In (96W)
- Bed Storage Box
- Skid Plates – Heavy-Duty – Front and Engine
- Fox Racing Shox™ with Live Valve Technology

INCLUDED PACKAGES RAPTOR

Packages refer to factory-installed equipment groups and option packages that come pre-configured with the vehicle. They enhance the vehicle beyond its standard features, adding additional functionality, styling, or performance upgrades as specified in the list below.

Equipment Group – High (801A)

Heated and Ventilated Front Seats

Adaptive Cruise Control & Full Driver Assistance Suite

B&O® Unleashed by Bang & Olufsen®
(14 Speakers including Subwoofer)

Head-Up Display

Cast Aluminum Sidesteps

Dual Exhaust with Black Tips

17" Wheels w/ 35" Tire

360-degree Camera

Mobile Office Package (50M)

Interior Work Surface

Flowthrough Console – Vinyl Lid

Under Seat Storage

Partitioned Lockable Fold-Flat Storage

Onboard 400 W Outlet

Wireless Charger

Bed Utility Package (68L)

Tailgate with Flexible Step

Power Tailgate

Box Light

Four Pickup Box Tie-Down Plates

Twin Panel Moonroof (43V)

Bedliner Tough Bed® Spray-In (96W)

EXTERIOR HIGHLIGHTS RAPTOR

Power dome hood features functional heat extractors to help lower underhood temperatures



Massive front skid plate provides underbody protection for the engine and transfer case

Distinctive Raptor® grille includes a carved "FORD" crossbar

Spray-in bedliner with four additional tie-down plates



Black leather-trimmed and Raptor® branded seats with sueded cloth inserts

Running boards are cast aluminum with spray-on boxliner material for slip resistance



360-degree external Zone lighting for those off-road adventures at dusk

17" cast aluminum wheels are fitted with 35" BFGoodrich® KO2 all-terrain tires



The tailgate appliqué with Magnetic-painted raised "FORD" lettering makes a bold statement

Functional heat extractors on the fenders help lower underhood temperatures

Unique Long-travel Rear suspension set-up

Raptor®-specific rear bumper includes two integrated tow hooks and highlights the true dual exhaust

F-150 XLT

3,500 KG
Max towing

895 KG
Max payload

555 NM
Torque

406 HP
Power





F-150 XLT 5.0L V8

Engine
5.0L V8 406HP

Fuel Consumption
14.36 L/100 km

Horsepower
406 Hp

CO2 Emission
342 g/km

Torque
555 Nm

KEY HIGHLIGHTS XLT

Technical Highlights

- 360-degree Camera with Front and Rear Parking Sensors
- Remote Start System with Remote Tailgate Release
- Adaptive Cruise Control
- 136 L Extended Fuel Tank
- 4×4 Electronic-Shift-On-the-Fly (4H / 4L / 2H)
- Intelligent Access with Push-Button Start (incl. Approach Detection)
- Pro Trailer Back-up Assist™ with Hitch Assist™

Interior Highlights

- 12" Digital Drivers display and SYNC® 4 infotainment
- 10-way Power Driver and 8-way Power Front Passenger Seat
- Heated Front Seats
- Wireless Apple CarPlay® and Android Auto™
- Navigation Center
- Dual-zone Electronic Automatic Temperature Control
- Power-Sliding Rear-Window with Privacy Tint and Defrost

Exterior Highlights

- 20" Chrome-Like PVD Wheels
- 6" Extended Running Boards
- LED Reflector Headlamps
- 360-degree Zone Lighting
- Bedliner Tough Bed® Spray-In (96W)

INCLUDED PACKAGES XLT

Packages refer to factory-installed equipment groups and option packages that come pre-configured with the vehicle. They enhance the vehicle beyond its standard features, adding additional functionality, styling, or performance upgrades as specified in the list below.

Equip Group Mid (302A)

6" Extended Running Boards

Heated Front Seats

Remote Start System with Remote Tailgate Release

Adaptive Cruise Control

10-way Power Driver and 8-way Power Front Passenger Seat

Chrome Appearance Package (86B)

Running Boards - 6" Chrome

Grille - Black Painted Coast-to-Coast Black Mesh with chrome Center Bar

Handles - Chrome - Door and Tailgate

Chrome single tip exhaust

Hooks - Front Tow 4x4 - two (2)

Wheels - 20" Chrome-Like PVD Wheel

Bumpers - Front - Chrome

3.73 Final Drive Ratio w/ Electronic Lock (XL6)

Bedliner Tough Bed® Spray-In (96W)

EXTERIOR HIGHLIGHTS XLT

Remote start system
and tailgate release



Black Coast-to-Coast Mesh
with chrome center bar

Dual Front
Recovery Hooks

Bedliner Tough
Bed® Spray-in



Single chrome
side-exit exhaust



Iconic 5.0L Coyote
V8 Engine

20" Chrome-like
PVD coated wheels

Active Front Air
Dam For Improved
Aerodynamics



360-degree Camera
with Front and Rear
Parking Sensors

6" Running Boards
with Chrome Detail



BUILT TOUGH. DESIGNED FOR EVERYDAY LIFE.



Off-road sequences were filmed on specially designated terrain with all required permits. The purpose of the footage is to illustrate the vehicle's driving capabilities. Please ensure compliance with applicable laws and regulations regarding off-road driving in your location.

Vehicles may be shown with optional equipment. Features may be offered only in combination with other options or subject to additional ordering requirements/limitations. Dimensions shown may vary due to optional features and/ or production variability. Information is provided on an "as is" basis and could include technical, typographical or other errors. Ford & Hedin US Motor makes no warranties, representations, or guarantees of any kind, express or implied, including but not limited to, accuracy, currency, or completeness, the operation

of the information, materials, content, availability, and products. Hedin US Motor reserves the right to change product specifications, pricing and equipment at any time without incurring obligations.

Fuel consumption (combined): 10.15-16.44 L/100 km; CO2 emissions (combined): 242-342 g/km. Consumption and emission figures are calculated according to Regulation (EC) 692/2008 and comply with California Code regulations. Note: values may not fully represent real-world driving conditions.

Published by Hedin US Motor AB.
©2026 Hedin US Motor AB

HEDIN US MOTOR

**READY
SET**
Ford™