



Foreword

Introduction

Xpeng's G9 is an AI smart luxury SUV with different characteristics than an ordinary vehicle. Please read this brochure before starting your G9 journey to find out the basics of the vehicle. The basic operation of the and the corresponding cautions. If you still have questions about the use of your vehicle, please contact Xpeng Service Centre.

The current user manual corresponds to the vehicle version V5.6.0 Tap “ → **General in the central control screen**” to view the current system version. If the system version is not up-to-date, please update it.

“*”The description with * in this manual applies only to some models. Your vehicle may not be equipped with these features.

The vehicle is capable of remote upgrade (OTA), vehicle features are constantly refined/updated

and the content of this manual will be updated from time to time.

This manual provides information on all configurations of the model, which may differ from the vehicle purchased due to differences in vehicle configuration, software version, etc. The actual car will be used.

Read the warning notes in the manual carefully:

 Be sure to observe such information as warnings, or personal injury or traffic accident may occur!

 Be sure to follow this information, as this may cause damage or malfunction to the vehicle!

 Informational information to help you make better use of your vehicle.

The illustrations in this manual are for information purposes only and are intended to illustrate the operation of the functions.

The illustrations in this manual are marked with:



- Indicates the object of the description.
- ⇨ Indicates the direction of the pan operation.
- ↻ Indicates the direction of the rotation operation.
- ↶ Indicates the direction of the flip operation.

No one may reproduce or modify the contents of this manual in whole or in part without the authorization of Xpeng Automobile. Xpeng Automobile always reserves the right to change, supplement or terminate the contents of this manual and the technical specifications.

Important

For your safety, please observe local laws and regulations when driving your vehicle and follow the following important tips when using your vehicle:

- When driving the vehicle, the driver should follow traffic regulations and control the speed of the vehicle to avoid overspeeding or overloading.
- Always wear a seat belt while the vehicle is in motion.
- Before driving the vehicle, make sure that the four doors and covers are closed, that the vehicle is in good performance and that all functions are used safely.
- Stay clear and never drive the vehicle after drinking or fatigue, as this may affect your control and result in injury or death.
- You must drive carefully to determine whether the weather and road conditions are suitable for travel, and keep an eye on other vehicles or pedestrians on the road at all times to make a timely judgment. Prevent accidents.



- Do not use your handheld to make and receive calls, view information, etc. while driving, as this may distract you and affect your control of the vehicle.



Appearance

Introduction

2

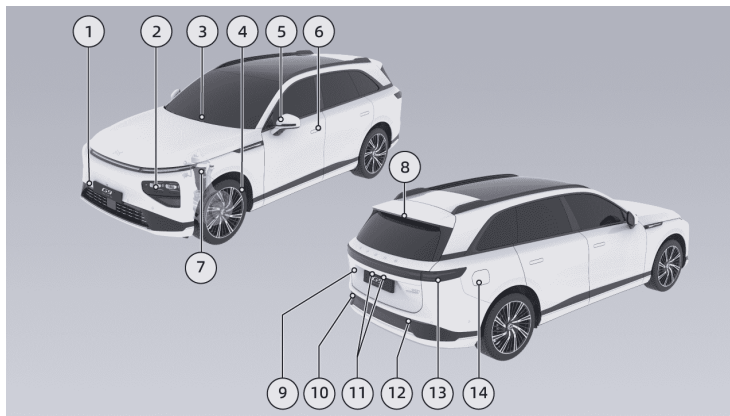

1. Towing hook cover

2. Headlight

- side lights, low beam, high beam [See 213 page](#)

• Smart high beam [See 228 page](#)

3. Front wiper

- Description of the wiper operation [See 217 page](#)



- Replacing wiper blades [See 309 page](#)
- 4. wheel
 - Tire maintenance [See 315 page](#)
 - Tire specifications [See 347 page](#)
- 5. Rear view mirror
 - Exterior mirror adjustment [See 281 page](#)
 - Heated exterior mirrors [See 209 page](#)
- 6. Car door
 - Unlocking and locking [See 186 page](#)
 - Keyless entry [See 182 page](#)
 - Open/Close [See 186 page](#)
 - Hidden electric door handle [See 184 page](#)
- 7. Air Suspension * [See 273 page](#)
- 8. High mounted brake light
- 9. trunk
 - Open/Close, Opening Angle, Emergency Open/Close [See 12 page](#)
- 10. Rear fog lamp
- 11. License plate light
- 12. Reversing lights
- 13. Tail lamps
- 14. Charge port cover
 - Charging port cover opening and closing [See 286 page](#)



Front row

Introduction

2

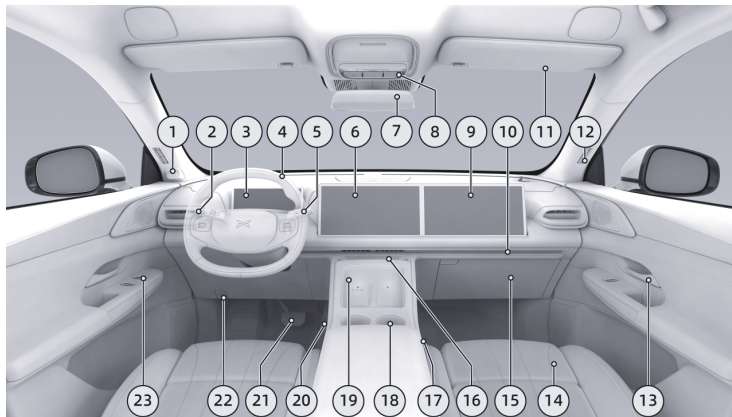

1. Interior camera

- See 142 page

2. Light & Wiper Stalks

- Introduction- See 213 page

- Introduction- See 217 page

3. Instrument cluster



- Instrument interface, instrument indicator- See 20 page
- 4. Steering wheel
 - Steering wheel keys, horn- See 240 page
 - Driver front airbag
 - Steering assistance adjustment- See 227 page
- 5. Gearshift paddles
 - Exterior mirror adjustment- See 219 page
 - Adaptive Cruise- See 88 page
 - Lane Centering Control- See 94 page
- 6. The central control screen- See 26 page
- 7. Automatic anti-glare interior rearview mirror See 231 page
- 8. Front roof lights
 - Reading light- See 250 page
 - Hazard warning lights- See 324 page
 - Emergency power off See 197 page
 - E-call*- See 340 page
- 9. Entertainment screen See 35 page
- 10. Ambience lighting- See 251 page
- 11. Sun visor and vanity mirror See 247 page
- 12. Side defrost vents
- 13. Interior door handle
- 14. Front seats
 - Seat adjustment- See 201 page
 - Seat Heating * See 253 page
 - Seat ventilation- See 255 page
 - Seat Massage * See 256 page
- 15. See 266 page
- 16. Air conditioning vents
 - Electrically adjustable- See 238 page
- 17. Front center armrest- See 266 page
- 18. Cup holder- See 266 page
- 19. Wireless charging for mobile phones- See 259 page
- 20. Accelerator pedal
 - See 225 page



- 21. Brake pedal
- 22. Front compartment lid release handle
- 23. Door switchpack
 - Window switch- See 243 page

- Door lock switch- See 184 page

Rear row

Introduction

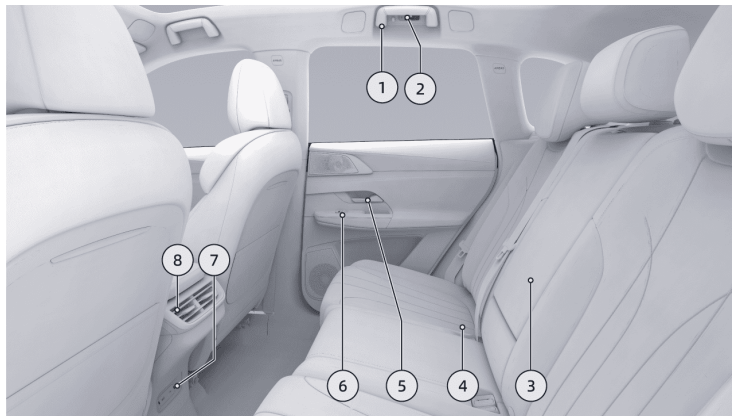

- 1. Ceiling handle
- 2. Rear reading- See 250 page
- 3. Rear center armrest introduction- See 266 page



4. Rear seats- [See 201 page](#)
5. Door handle- [See 184 page](#)
6. Door switchpack
 - Window switch- [See 243 page](#)
 - Backrest adjustment- [See 201 page](#)
 - Seat Heating *- [See 253 page](#)
 - [See 255 page](#)
7. [See 262 page](#)
8. Air conditioning vents
 - Manually adjust the- [See 238 page](#)



Trunk

2

Introduction

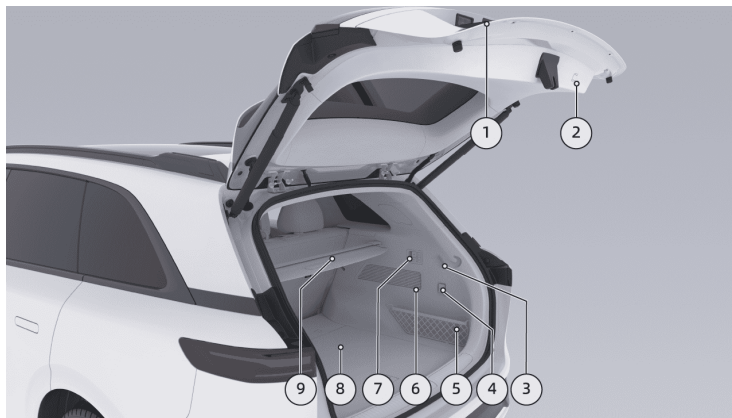

1. Loadspace exterior switch

• See 188 page

2. Luggage compartment interior switch

• See 188 page

3. Loadspace lighting- See 188 page

4. 12V power interface- See 262 page

5. Trunk net bag- See 266 page



6. Loadspace service cover
 - Emergency unlock- [See 293 page](#)
7. Loadspace combined switch
 - Seat backrest fold switch
 - Easy loading
8. Loadspace cover
 - Vehicle companion kit, warning triangle-
[See 324 page](#)
9. Blind



Front compartment

Introduction

2

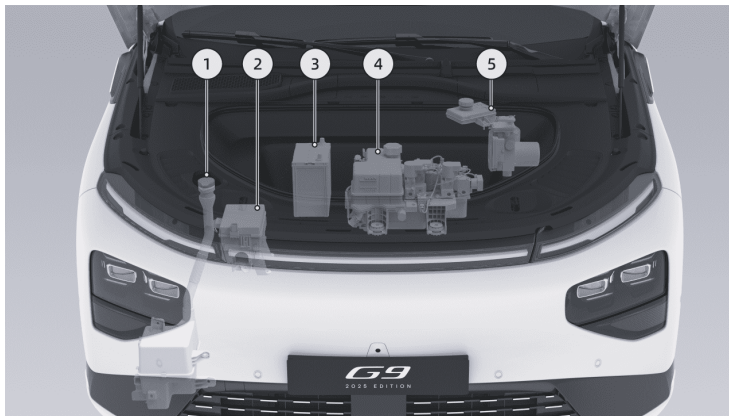

1. Windshield washer fluid reservoir

- Inspection and filling- [See 308 page](#)
- Filling amount- [See 353 page](#)

2. Front compartment fuse box

3. Battery

4. Coolant reservoir

- Inspection and filling- [See 303 page](#)
- Model and filling amount- [See 353 page](#)



5. Brake fluid reservoir

- Inspection and filling- See 305 page
- Model and filling amount- See 353 page



High voltage components

Introduction

2

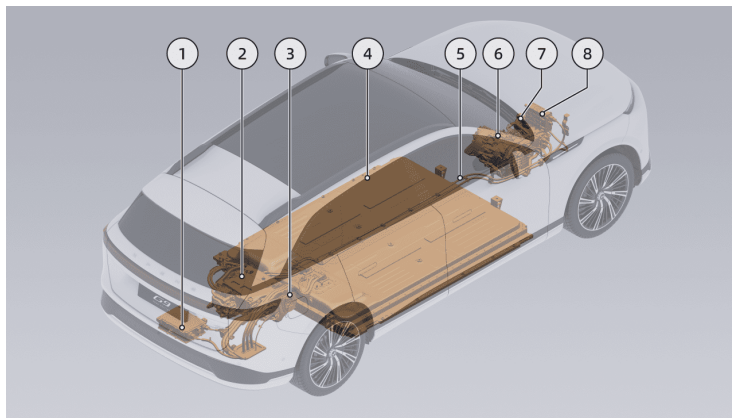

1. Charger/DC converter
2. Rear electric drive system
 - Type and parameters- [See 351 page](#)
3. Charging port
 - Charging port cover opening and closing- [See 286 page](#)
 - Charging Operation- [See 288 page](#)
 - Emergency unlock- [See 293 page](#)



- Discharge to the outside- [See 297 page](#)
4. Power battery
 - Power battery maintenance and recycling- [See 311 page](#)
 5. High voltage wiring harness
 6. Front Electric Drive System *- [See 351 page](#)
 7. Air conditioning compressor
 8. - Heating water heater

i Tips

It is prohibited to touch, disassemble the highvoltage wiring harness or connect the highvoltage components of the high-voltage wiring harness, otherwise there is a risk of electric shock.



Intelligent Driving Assistance - Hardware

Radar

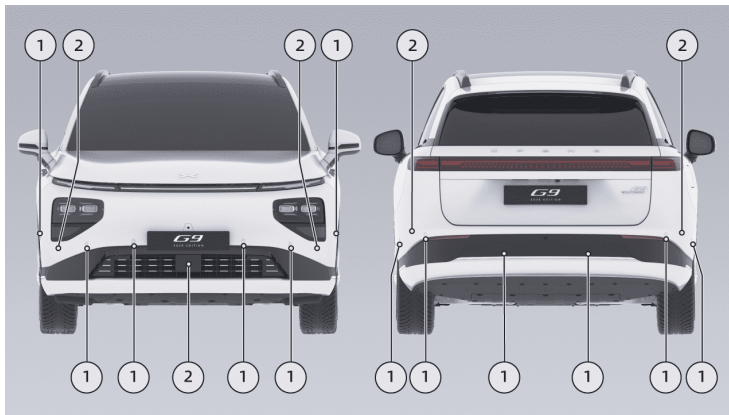

- 1. Ultrasonic radar
- 2. Millimeter radar



Camera

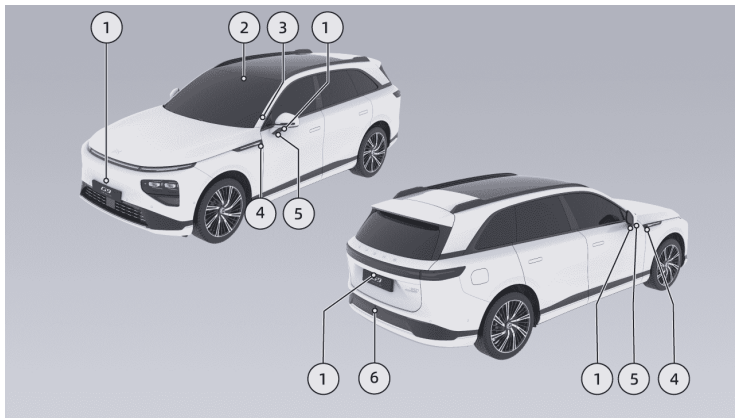

1. Walk around camera
2. Dual-eye camera
3. Intelligent camera in the car
4. Side rear camera
5. Front side camera

6. Rear view camera

⚠ warning

If the radar and camera functions are restricted, the assisted driving function will not be able to be turned on or function normally.

Cluster Display

The page displays

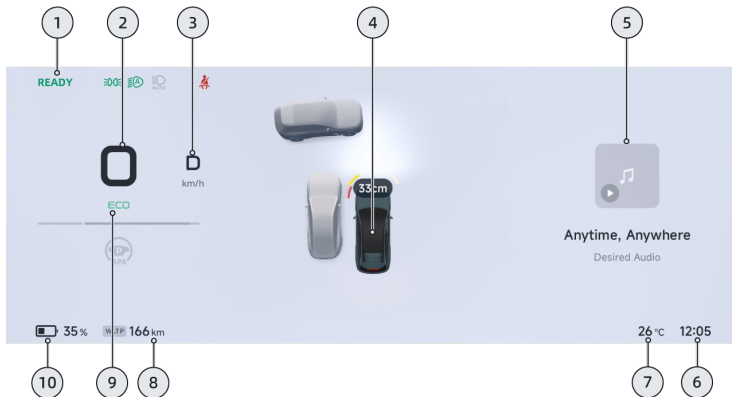

1. Indicator light

- The indicators are distributed in different positions on the instrument to reflect the status of the vehicle's functions.



2. Vehicle speed

3. Gear position

4. Intelligent Drive

- Displays the status of the vehicle.



- Displays the simulated vehicle exterior environment.
5. Right-hand information display
 - Information can be changed via the steering wheel scroll wheel and can be selected for condition, energy consumption, mileage, Navigation, music, etc.
 6. Time
 7. Outside ambient temperature
 8. Range
 - In the center control panel “→**Charging and Discharging**→**Charging**”interface, The display of WLTP/Dynamic can be toggled.
 9. Driving mode
 10. Power gauge
 - In the center control panel “→**Charging and Discharging**→**Charging**”interface, Turns the “**Battery Percentage Display on/off**”in the next step.

Instrument indicator lights

Some of the indicators will illuminate when the vehicle is powered up and will extinguish when the system has completed a self-test, for example, the system OK indicator. Some of the indicators are illuminated to show the current state of the vehicle system functions, not a system fault. If there is anything unknown in your daily car, you can consult the Xpeng Service Center.



High beam on



Air bag fault



Intelligent high beam is on and high beam is on



Driver seat belt not fastened



Intelligent High Beam fault



The secondary driver's seat belt is unfastened



Intelligent high beam is on and high beam is not illuminated



Rear left passenger seatbelt unfastened



Left turn signal lamp illuminated



Rear center passenger seatbelt is unfastened



The right turn signal is illuminated



Rear right passenger seatbelt unfastened



Low beam light on



Speed limit sign speed limit



The rear fog lamp is on



Low washer fluid level indicator



Side lamps on



The high pressure system is ready and the vehicle is in a driveable state



Automatic headlight control is on and low beam lights are on



Faulty battery



The charging cable is connected



Powertrain fault



Timed charging is on



The motor and the controller are overheating



There is a fault with the steering system

















The motor and controller are faulty



Solid: Parking is active
Flashing: Incorrect caliper status



Power battery temperature too low

	Solid: Parking brake fault Flashing: The parking system is in service mode		Power battery temperature too high
	Automatic parking is activated		The power battery is low
	There is a fault with the automatic parking		The power battery is faulty
	There is a fault with the brake system		The power battery is switched off
	Blinking: Electronic stabilization system activated Solid: Faulty electronic stability system		Forward collision warning fault
	Electronic stability system switched off		Forward Collision Warning Off
	Anti-lock braking system fault		Too many lights are lit at the same time, the indicator shows that the position is full



Reduced braking performance



Assisted driving fault



Hill descent is active



Abnormal tire pressure or tire pressure monitoring system fault



Hill descent fault



Doors, front compartment lid, boot not all closed



Drive power limitation



Lane Centre Assist is active



The maximum speed limit for ACC/LCC and any function is activated



Lane Centre Assist can be activated



Maximum speed limits for ACC/LCC and none active



Super Park is active



Air suspension function fault



Super Smart Parking is active



Serious air suspension failure



Adaptive Cruise is active



Air suspension firmness adjustment



Adaptive Cruise can be activated



Super Park is not available



Adaptive Cruise is not available



Intelligent Speed Limiter is active



Lane Departure Assist fault



Lane Centre Assist is not available



Trailer function fault indicator *



Trailer function not switched on indicator *



Trailer function OK indicator *

Central Control Screen

The page displays

The central control screen shows split screen status by default. The map navigation screen is displayed on the left and the full range smart drive screen is displayed on the right.

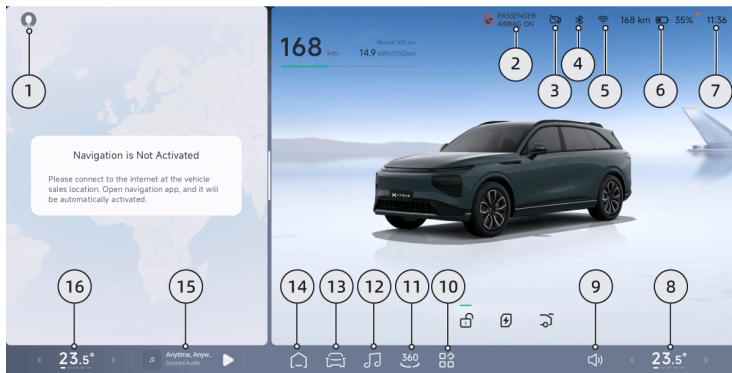



1. Account number & customary [See 55 page](#)
2. Passenger Airbag Disable Switch
3. Driving video *
 - Displays the current trip recording status.
4. Bluetooth
5. Network
6. Power battery
 - Displays the current range and remaining power.
7. Time
8. Passenger air conditioning unit
 - Displays the temperature and air volume status of the current passenger air conditioning.
 - Tap to adjust the air conditioning [See 233 page](#) .
9. Volume adjustment
10. Application Center
11. 360 Image [See 72 page](#)
12. Music APP [See 59 page](#)
13. Settings
 - Access to the vehicle settings.
14. Home Page:
 - Tap to return to the desktop.
15. Media playback interface
 - Displays the media cover, media name, and playback source currently playing.
 - Tap to pause or resume music playback.
 - Swipe left or right for the previous or next action.
16. Main drive air conditioning components
 - Displays the current host air conditioning temperature and air volume status.
 - Tap to adjust the air conditioning [See 233 page](#) .



Split-screen multitasking

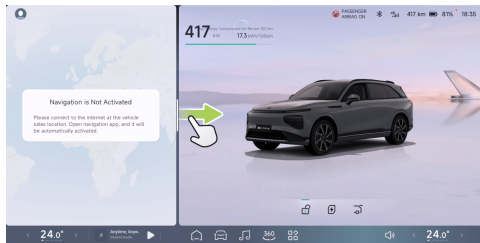

Drag the split line to toggle the full/split screen state and change the size of the form when split. When split-screen switches to full-screen, the last open split-screen application is remembered.

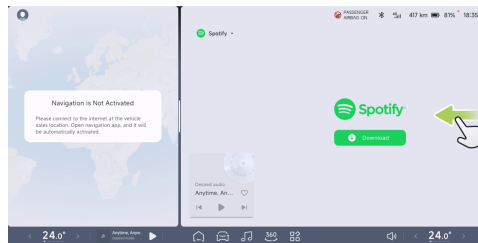

3

Swipe side to return to the page above the corresponding window.

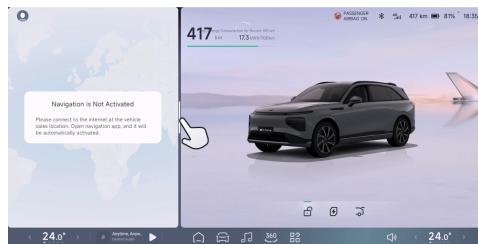

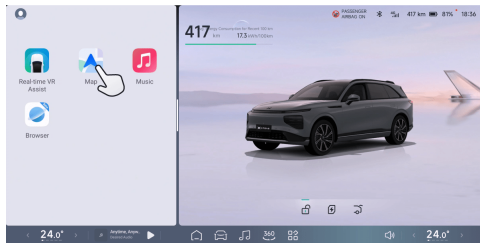

Tap the split-screen line to fix the small window App, supporting display of global smart drives, maps, and music.

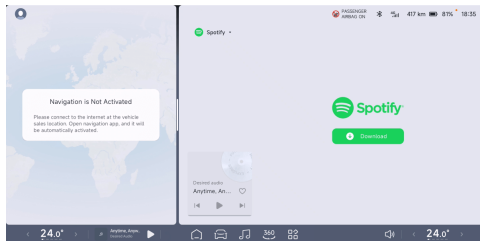

The large windows under split screen support different applications to open, the main drive to watch the navigation, the secondary drive to watch the video, listen to songs and read the lyrics.

Gesture interaction

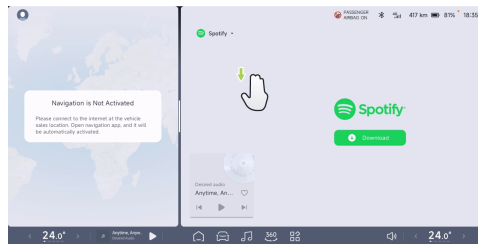

The three-finger swipe gesture returns to the desktop and, in a split screen, exits the app that opens at the app's large window and returns to the desktop.

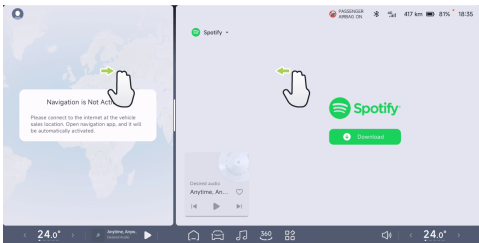

In split screen, three or four fingers swipe left or right at the same time to complete window application swapping.

The bottom taskbar area does not participate in gesture operations. During the swap process, the status bar and the bottom taskbar are not hidden.

Move from the central control screen to the entertainment screen: With the central control screen in full screen, swipe right with three points to stream app content with app sharing capability from the central control screen to the entertainment screen for operation.

Move from Entertainment Screen to Centre Control: Use the three-point swipe left to stream app content from the Entertainment Screen with app sharing capabilities to the Centre Control Screen for operation.

Customize the bottom taskbar

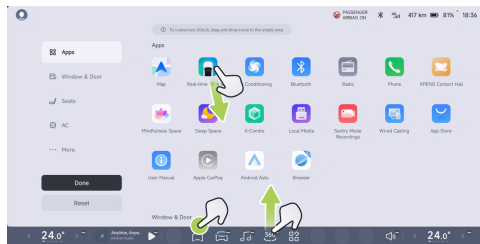

1. Customize the bottom taskbar by long-pressing any area of the bottom taskbar icon.
2. Function controls and shortcut component icons in applications and doors, windows, seats, climate can be dragged to the bottom taskbar space.



3. You can remove the icon from the bottom taskbar by clicking in the upper-right corner of the icon in a custom state, or by dragging the icon to the app to release it.
4. Tap “Done” or an empty space in the bottom taskbar to exit the custom state.

Application Center

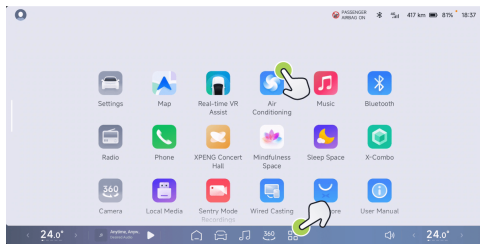

1. Tap the bottom task bar to open the App Center and tap any empty space in the App Center to quickly exit.

2. Tap the app icon to open the app, and apps that are being downloaded and installed have a corresponding status.
3. Long-press the app icon or blank space to enter the custom app center state, which now supports dragging the icon to sort within the app list.

Shortcut panel

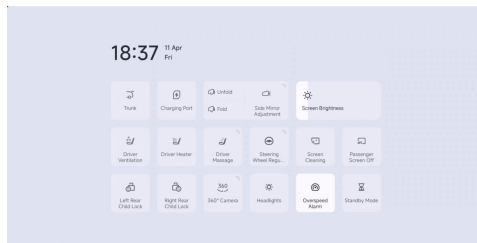

For high-frequency functions, you do not need to open the application, and you can work directly from the shortcut panel. Swipe from the top of the screen to expand the shortcut panel,



and swipe up to collapse the shortcut panel. When you click an empty space or open a new screen, the shortcut panel is collapsed.

Display settings

Brightness adjustment

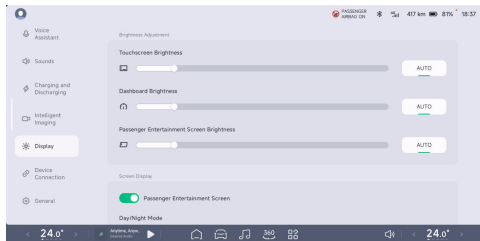

In the Center “🚗 → **Display screen**”, Drag the progress bar to adjust the Main Drive Screen brightness, Instrument Screen brightness and Passenger Entertainment Screen brightness.

Display mode

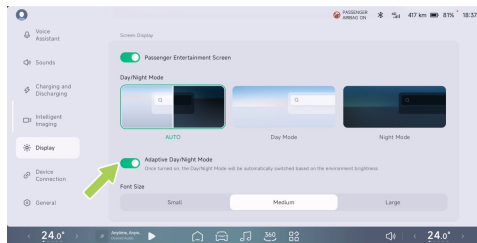

In the Center “🚗 → **Display screen**”, Auto, day mode, night mode can be selected. “**Adaptive Day/Night Mode can also be switched on/off**”. When switched on, the automatically switches to day/night mode depending on the ambient light.



Wait mode

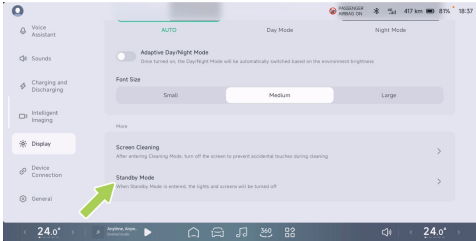

3

In the center control screen “”
→**Display**”interface, to enter “**Standby Mode**”,
“”After entering Standby Mode, The lights, the large screen and the instrument switch off.



Entertainment Screen

The page displays

The entertainment screen is mainly video content, click on the video to directly enter the video screen.

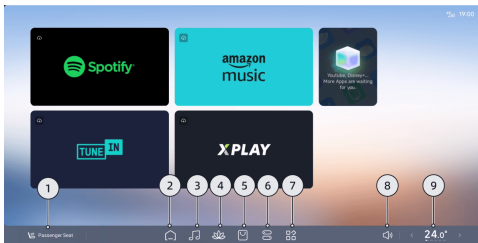



1. Passenger Seat Assembly
2. Home Page:
3. Music
4. Meditation space
5. App Store
6. Shortcut panel

7. Application Center
8. Volume adjustment
9. Passenger air conditioning unit

Long press the taskbar icon at the bottom of the entertainment screen to customize the bottom taskbar.

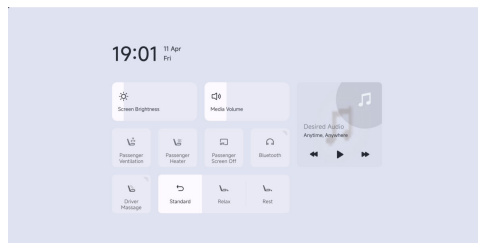
Shortcut panel





For high-frequency functions, you do not need to open the application, and you can work directly from the shortcut panel. Tap the entertainment screen  and swipe from the top



of the screen to expand the entertainment screen shortcut panel. When you click an empty space or open a new screen, the shortcut panel is collapsed.

App sharing

In apps with app sharing capabilities, Click,  When the pop-up window appears, Tap  to share the video or app between the central control screen and the entertainment screen.

Look together

In video applications, Click,  When the pop-up window appears, Click  to enable the video

content to be played simultaneously with the entertainment screen.

Voice Assistant

Voice control

Voice Control allows the driver to control the vehicle's features while driving. Please using voice commands to avoid distractions and improve driving safety and convenience

Common voice control commands (English)

Category	Function	Sample voice control commands



Vehicle	Seats	Raise driver seat higher
		Move driver seat back to the front
		Activate driver's seat massage
		Change second row seat massage mode
		Turn on front massage to low
	AC	Turn on AC
		Driver ac temperature turn higher
		Turn on driver auto ac
		Turn on purifier
		Turn on recirculation
		Turn on max cooling
		Turn on max heating
		Turn on refresh mode
		Open seat ventilation
37	X P E N G	



Phone	/	Make a call
		Call Anna
		Call back
Navigation	/	Navigate to
		Exit navigation
		Take me home
Media	/	Next song
		Pause
		Turn off music
		Play music



Others	Screen	Turn up main screen brightness by 10%
		Dashboard brighter
		Change to day mode
	Device	Turn on driver Bluetooth
		Turn on the Wi-Fi
		Turn on camera

Gängige Sprachsteuerungsbefehle (Deutsch)

Category	Function	Sample voice control commands
----------	----------	-------------------------------



XPENG Fahrzeug	Sitz	Verstelle den rechten Rücksitz nach vorne
		Neige die Rückenlehne des Fahrers nach vorne
		Aktiviere die Sitzmassage des Fahrers
		Aktiviere wave Massage des Vordersitzes
		Stelle die Massageintensität auf Stufe hoch ein
	Klimaanlage	Schalte die Klimaanlage des ganzen Fahrzeugs aus
		Senke die Temperatur auf der Beifahrerseite
		Erhöhe den Luftstrom
		Stelle Klimaanlage auf Automatikmodus ein
		Reinige die Luft
	Schalte die Umluft aus	



Telefon	/	Mache einen Anruf
		Rufe Anna
		Rufe 101
		Rufe zurück
Navigation	/	Wo ist die Seite für Klimaanlage
		Schalte Navigation aus
		Bringe mich nach Hause
Media	/	Vorheriges Lied
		Pausiere
		Spiele Musik
		Schalte Sotify ein



Sonstiges	Bildschirm	Erhöhe die Bildschirmhelligkeit um 20%
		Erhöhe die Heiligkeit des Armaturenbrettes
		Erhöhe die Bildschirmhelligkeit des Armaturenbretts
	Geräteverbindung	Schalte Bluetooth ein
		Schalte 360° Kamera aus

**Commands de contrôle vocal courantes
(français)**

Category	Function	Sample voice control commands
----------	----------	-------------------------------



Véhicule	Sièges	Monte le siège passager
		Incline le dossier du siège conducteur vers l'avant
		Active le massage, s'il te plaît
		Donne-moi un autre type de massage
		Active le massage du siège conducteur à faible intensité
	Climatisation	Allume toutes les climatisations
		Augmente la température de la climatisation
		Accrois le volume d'air
		Active la climatisation automatique du conducteur
		Ferme le purificateur d'air
		Active la recirculation de l'air
		Arrête le dégivrage
		Refroidissement max
		43



Téléphone	/	Passé un appel téléphonique
		Appelle le service client
		Appeler 123
		Recompose
Navigation	/	Navigue vers
		Termine la navigation
		Rentrer à la maison
Média	/	La chanson précédente
		Arrête la diffusion de la radio
		Joue de la musique



Autres	Écrans	Augmente la luminosité de l'écran
		Tableau de bord plus lumineux
		Mets la luminosité du tableau de bord en mode automatique
	Appareils	Active le Bluetooth
		Active le WIFI
		Ouvre la caméra

คำสั่งควบคุมด้วยเสียงทั่วไป (ภาษาไทย)

หมวดหมู่	การทำงาน	ตัวอย่างคำสั่งควบคุมด้วยเสียง
----------	----------	-------------------------------



รถยนต์	เบาะ	ปรับเบาะนั่งไปข้างหลังน้อย
		ปรับพนักพิงหลังผู้โดยสารด้านหน้าไปข้างหลังสุด
		เปิดฟังก์ชันการนวดเบาะนั่งของคนขับ
		ปรับแรงนวดของเบาะคนขับให้สูงขึ้นนิดหน่อย
	เครื่องปรับอากาศ	ปิดเครื่องปรับอากาศทั้งคันรถ
		ปรับอุณหภูมิของที่นั่งคนขับสูงขึ้นเล็กน้อย
		เพิ่มความเร็วลมของเครื่องปรับอากาศในที่นั่งด้านหลัง
		เปิดการไล่ฝ้ากระจกหลัง
		ปิดการอุ่นเบาะของผู้โดยสารด้านหน้า
	46	ปิดไฟตัดหมอก
		เปิดไฟสร้างบรรยากาศ
		ตั้งไฟสร้างบรรยากาศเป็นสีแดง



โทรศัพท์	/	โทรศัพท์
		โทรหาผู้ติดต่อ
		โทร 123
		โทรหมายเลขเมื่อไหร่
การนำทาง	/	นำทางไปที่
		ไปที่บ้าน
		นำทางไปบริษัท
สื่อ	/	รายการวิทยุก่อนหน้า
		เพลงถัดไป
		หยุดเล่น
		เล่นเพลง



อื่น	หน้าจอ	เปิดหน้าจอทั้งหมดในรถ
		ปรับหน้าจอให้สว่างขึ้น
		เปิดความสว่างอัตโนมัติของหน้าจอ ด้านหน้า
	อุปกรณ์	เปิดบลูทูธ
		เปิดกล้อง
		เปิดกล้องหน้า

常用语音控制指令 (粤语)

分類	功能	語音控制指令範例
----	----	----------



車控	座椅	主駕座椅調高
		主駕座椅靠背調前
		啓動主駕座椅按摩
		主駕換個按摩模式
		司機按摩力度較到低
	冷氣	打開全車空調
		前座溫度較低
		空調風大啲
		啓動自動空調
		打開空氣淨化模式
		打開外循環
		打開前除霧
		打開智能除味
		打開座椅通風
	49	開司機座椅加熱 $\text{P} \equiv \text{N} \text{G}$
	打開自動大燈	



電話	/	打電話
		打個電話畀 Anna
		重撥
		回撥
導航	/	導航去
		退出導航
		返屋企
		去公司
媒體	/	播上一個廣播
		播放音樂
		下一首歌
		停止播放



其他	螢幕	螢幕調亮
		儀表屏亮度調高
		打開儀表屏自動亮度
	設備鏈接	打開藍牙
		打開 wifi
		打開攝像頭

X-Combo

Car App

Feature entry



Tap the CID “”, in the application center “**X-Combo**” to enter the Intelligence scene interface

Pick a scene

Intelligence scene selects a series of creative and practical car use scenarios. It can be picked up in the “**Recommend**” interface, Click on “**Driving combo**” to view the scenario details. Log

in to your account from the CID. Tap “+ **Add**” to add to my scene.

My scene

You can enable/deactivate/delete/run the scenario by logging in to the account in the CID.

Scene editing

Intelligence scene supports custom editing of the cards in my scene.

1. Log in to your account on the CID, under the My Scene screen, click the scene card to enter the card details screen.
2. Click … “**Modify Combo**” from the icon drop-down menu.
3. Use the Xpeng APP to scan the QR code for editing.

Tips

After the scene is changed, both the car computer and the mobile phone must be



connected to the Internet for the update to be synchronized.

Run a review

The enabled scenario automatically performs one or more sequential functions when the vehicle meets the set trigger conditions. You can click **“Smart scene is running”** on the status bar above the CID to view or stop the currently running scene.

One-click recovery

Both when and after the Smart Scene is run, you can revert to the state it was in before the scene was run in the following ways:

- When the scene is running, You can click the **“Smart scene is running”** on the upper left corner of the central control screen. In the expanded live card, select the scene that needs to be recovered, Click **“Resume”** to stop the scene and return to the state it was in before it was run.

- When the scene is running, You can also tap in sequence from the center control screen “☰ → **Smart Scene** → **My Combo**” Medium, Click on the corresponding scene to **“recover”** The scene is stopped and returned to the state it was in before the scene was run.
- After the scene runs, From the center control screen, tap one after the other “☰ → **Smart Combo** → **My Combo**” Medium, Select the scene you want to restore, Click **“Resume”** to stop the scene and return to the state it was in before it was run.

i Tips

Currently, the capabilities that support recovery include air conditioning, seat position, and screen display. Subsequent versions will add more recoverable capabilities.



Mobile App Bluetooth key

Feature entry

In the Xpeng APP “XPENG→X-Combo”interface, to make your own scene settings.

Pick a combo

Smart Scene A selection of innovative and practical car scenarios. You can choose from the “**recommended**”interface. Click on “**Dring Combo**”to view the scenario details. Tap “+ Add” to My Combo. At the same time, it can be “”adjusted according to your own car habits through custom editing.

Tips

After the scene is changed, both the car computer and the mobile phone must be connected to the Internet for the update to be synchronized.

Personalize

X-Combo support the need for personalization of cabin features. Click “**My Combo**→++**Create a Combo**” to start personalization.

The system provides “**In-car trigger**” “**Remote trigger**”both in-vehicle triggering and remote triggering modes of operation. Support time, environment, vehicle state, etc. as trigger conditions for automated operation, It also supports a wide range of programmed actions such as driving mode adjustment, climate settings, etc.

You can also “”achieve multiple-condition, continuous-sense judgment with advanced settings. High-level applications such as simultaneous multitask execution and instruction delay execution.

caution

1. When the scene is running, please ensure the safety of the vehicle and personnel.



2. It is recommended to select the " **Smart Query**" mode when " **Creating a Scene**". In this way, the scene safety level will be judged according to the vehicle status before the scene task is executed on the vehicle side. If there is a driving safety risk (such as adjusting the driving mode in D gear), the small P smart recommendation card on the central control screen will ask whether to execute the scene; if "

Do not ask" is selected, the scene will be executed immediately when the trigger conditions are met. Please pay attention to the relevant safety risks.

User Accounts

Account type

Owner's account

Download the Xpeng Motors app on your mobile and sign in with your mobile number, and you're done registering your account. If all the vehicle's

features are required (for example, account memory), complete the vehicle account bonding.

When you purchase a vehicle, the first time the Handover link has linked the account of the active vehicle is the owner's account, only one owner account can be linked to a vehicle, but multiple vehicles can be linked to an account.

Family and friends accounts

After the owner logs in to the Xpeng App, tap "**Xpeng→Settings→Vehicle authorization→add**", Enter the authorized person's mobile number and set the validity period as needed to share the vehicle usage rights with friends and family. Once an authorized user has logged in to the Xpeng App, they can create a Bluetooth key or use the remote vehicle function. Authorize up to 5 friends and family.

The owner uses the Xpeng App to access ""the vehicle authorization screen to view or manage the authorized users. Locate the user who needs to be unauthorized ""and click Unauthorize. to disauthorize the user.



Log in to your account

When sharing a vehicle with multiple people, log in to the account and the system automatically adjusts the seat, exterior mirror position and other functions for you. You can log in to your account in one of the following ways:

- Once your mobile phone is logged into your Xpeng App account, unlocking the vehicle via the Bluetooth key will automatically log into the user account.
- Click the avatar in the upper left corner of the central control screen, the mobile phone to log in to the Xpeng APP account and scan the code to log in.

Account memory

Once logged into the account, personal car usage can be recorded (e.g. seat position, exterior mirror position, etc.). A maximum of 6 usage habits can be stored in one account. After clicking on the central control screen user image,

you can quickly select the car habits that need to be performed this time.

Tap the central control screen “**User Avatar**→**Settings**” After, Saved host vehicle habits can be added or renamed from the Account Settings screen.

Wireless Casting

Introduction

It supports wired screen projection, allowing you to easily project the images of game consoles, computers and other devices (including Switch, MacBook, etc.) to the large screen of the car and enjoy an unprecedented visual feast.



Operation

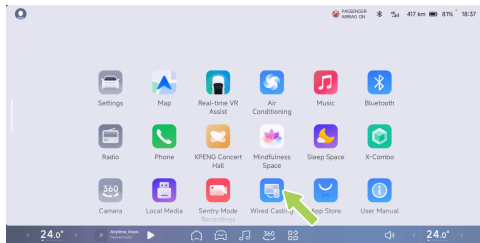

1. Tap the center control screen “”, Click “**Wired Casting in the App Center**”.

Tips

Switch requires an additional PD charging cable for power supply. One end of the charging cable is plugged into the video capture card or HDMI, and the other end is connected to the front Type-C port.

2. Connect the front Type-C or Type-A connector using an HDMI cable and a video capture card.
3. The connection is successful and the screen is displayed on the screen.
4. Wired projection screen:
 - Swipe left up or down to adjust the screen brightness.
 - Swipe up or down on the right to adjust the media volume.
 - Supports contact mute.
5. Click the screen, and tap “**Exit Projection**” in the upper left corner to exit the projection screen.

Tips

Sony PS, Xbox, etc. are not recommended to use the in-car transmission port for screen projection due to their high voltage requirements. However, you can use the external power port to power the device for screen projection after parking.



Navigation

Seamless navigation

Introduction

When you log in and integrate your phone app, seamless navigation enables you to quickly initiate navigation by sending an address to the car from your phone.

Operation

Take the Xpeng Car APP as an example, seamless navigation can be achieved by:

1. Tap the **“Xpeng→search box on the mobile APP screen”**, Set the navigation destination.
2. Tap **“Send to Vehicle to”** send the destination information to the vehicle central screen.
3. A confirmation card will pop up when the navigation information from the phone is received in the central control screen. Click **“OK”**, seamless navigation.

Charging Planning

When traveling long distances, the system automatically routes your journey and charging according to your charging preferences.

1. In the central screen map interface, Tap **“Map Settings”** Adjust **“”**Minimum charge at the charging station and minimum charge at the end point in Charging Route Preferences.

i Tips

If the current charge is sufficient to reach the destination, no charging station will be added automatically.

2. Tap **“Charge on the Route Planner screen”** to enter the Smart Charge Planner screen. The system will automatically plan the charging stations along the way, displaying information about the charging stations passing through, distance between trips, and the number of recharges in a timely manner. Tap **“Start Navigation”** to start the journey.



- 3. The distance to the charging station, estimated time of arrival, is dynamically updated while driving.

XPENG Music

Introduction

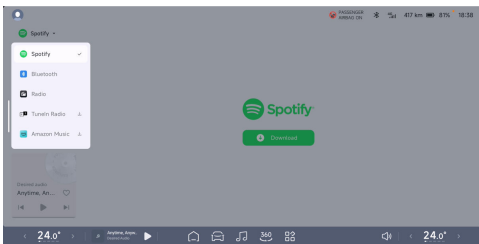

Xpeng provides a defined music application, supported by sources including Spotify, Radio, Bluetooth and more.

Tap the taskbar at the bottom of the central control screen “🎵”, Source switching and

playback can be done in the top left corner of the music screen.

Radio

The vehicle supports local station FM.

Switch the source to “**Radio to**” play the local station.

Bluetooth

Switch source to “**Bluetooth**”, “After you tap Connect Bluetooth to connect your phone to Bluetooth, You can listen to the songs on your phone in your car.

Sound Settings

Introduction

In the “🔊 → **Sounds screen**” of the central control screen, The vehicle sound can be set.

Volume adjustment

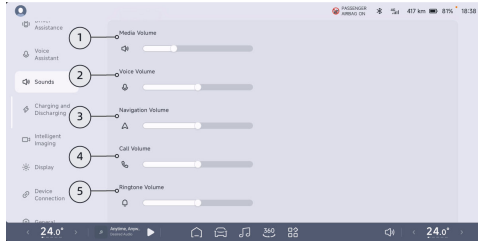

1. Adjust the media volume.
2. Adjust the voice announcement volume.
3. Adjusts the navigation broadcast volume.
4. Adjust the call volume.
5. Adjust the ringer volume.

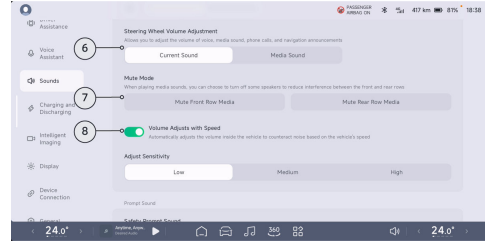

6. Steering wheel volume adjustment: Tap to set the type of volume adjustment via the steering wheel scroll wheel.
7. Mute Mode: Tap to turn off front or rear media sound to reduce front and rear interference when playing media sound.
8. Volume adjust with speed *: Click on to automatically adjust the interior volume to counteract the noise, depending on the speed of the vehicle, or select a different sensitivity level to suit your driving style.



Tone

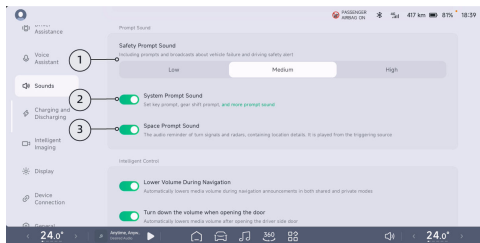

1. Security Tones: Click to set the audible warning and the level of volume to be announced for vehicle faults and driving alerts.
2. System Tones: Key Press Tones, Gear Shift Tones, The exterior charging gun tone and driving mode sound can be set at “**more prompt sound**”is turned on or off in the.
3. Space Tones *: When you tap on the feature, the signals with space orientation, such as turn signals, radar, etc., sound from the trigger position.

Intelligent regulation

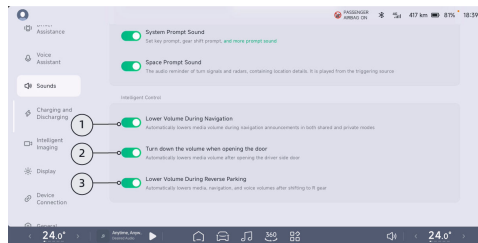

1. Volume down while navigating: When you tap on the feature, the media volume automatically decreases when navigating during playback in the shared and private modes.
2. Door Volume Down: When you tap the Open feature, the media volume automatically decreases when the main door is opened.
3. Reverse decrease volume: After clicking on the function, with R, media, navigation, the voice volume decreases automatically.



Device Connection

Introduction

You can connect your device via Bluetooth in the car, a wireless network or a hotspot in your car.

Operation

Bluetooth

In the “ → **Device Connection screen**” or the status bar at the top of the central control screen, Bluetooth can be switched on/off, “”When Allow Detection is turned on, Other Bluetooth devices can discover the vehicle's Bluetooth.

Select the mobile device that needs to be paired on the Bluetooth device interface and follow the interface prompts to complete pairing.

Once paired, the mobile phone can confirm that the communication data (e.g. contacts, call logs) from the mobile device is synchronized to the vehicle, making it easier to answer and make calls. Better experience with in-car phone

features. Music from your phone can also be played via the in-car audio.

Wireless network

In the “ → **Device Connection screen**” or the status bar at the top of the central control screen, The wireless network can be turned on/off.

When switched on, the vehicle will automatically scan for wireless networks, select the wireless networks that need to be connected and enter the password to connect.

Tips

- You can use the wireless network function to connect to and use the personal hotspot shared by your mobile phone. Please pay attention to the traffic consumption when using it.
- You can check the signal strength of the current connected network through the wireless network icon in the status bar. If the



signal strength is low, the vehicle's Internet speed may be slow.

Car Hotspot

In the center control screen “ → **Device Connection**” interface, You can turn on/off the in-car hotspot and select the hotspot mode 5GHz or 2.4GHz.

Use another mobile device to search for a local car hotspot and enter the password to connect.

Tips

It is recommended to give priority to the 5GHz band. Enabling the 2.4GHz band can make more devices compatible, but the network performance will decrease.

System updates

Notices and Limitations

- Make sure that the vehicle has more than 10% of its charge remaining, is in Park (P) and is parked in a safe area before updating.
- Unable to abort after entering the update, vehicle will not be available during the update, please allow sufficient time for the update to complete.
- The vehicle will not charge during the update process, please schedule the update and charge time appropriately.
- Failure of the system update may result in some unexpected functionality. Do not use the vehicle if the update fails. Tap “**Retry to**” retry the update. If multiple attempts are unsuccessful, please contact Xpeng Motors Service Center or Customer Service Center.
- Unable to rollback historical version after system update.

Xpeng App

Introduction

After your phone downloads and logs into the Xpeng App, you can remotely check the vehicle's condition and control some of the vehicle's features.

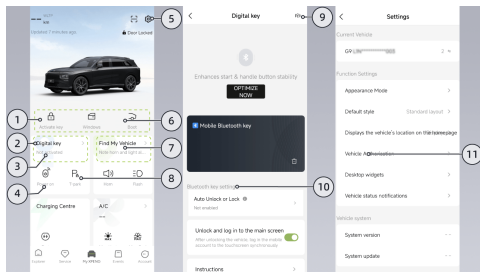

1. Vehicle lock

- When the handset key is not activated: Tap the **“activation key”** to activate the handset key. After successful activation,

“The original activation key changes to **“Vehicle lock”**.”

- When Bluetooth is not connected: Tap to select **“unlock only or unlock start”**.
- When Bluetooth is connected: Tap to **“unlock the”** vehicle and within 20 minutes to engage the gear to start the vehicle.

i Tips

- Do not close the mobile app after unlocking, and keep the mobile app in the background, otherwise you may not be able to shift gears.
- If you cannot shift gears, try reopening the mobile app.

- Digital Key: Click to enter the Digital Key screen for Bluetooth key setup and key check.

i Tips

- When the mobile phone key is connected to the vehicle's Bluetooth, it can be used in a



garage or other environment without network signal.

- When the vehicle is equipped with both media Bluetooth and key Bluetooth, the mobile phone key will automatically connect to Bluetooth without pairing on the central control screen.

- Usually, the Bluetooth connection range in an open space is about 20 meters, which may vary due to factors such as the mobile phone Bluetooth hardware, environmental occlusion and interference, etc.

3. Bluetooth status: Phone key is blue when connected to the vehicle Bluetooth, gray when not connected.
4. Remote Start: Tap the rear door to unlock, and within 2 minutes the brake pedal is pressed to engage the vehicle to allow the vehicle to be driven temporarily.
5. Settings: Click to enter the settings screen.
6. Shortcut bar: Long press in this area to customize the function of the shortcut bar for up to 8 functions.
7. Vehicle location/map
 - Only the owner account number can view the real-time location of the vehicle.
8. Immobilization: When the vehicle central screen “**auto power down**” is switched off and the vehicle is powered up. Gear in P, Open the mobile app “**Xpeng**” interface. Click “**Stop**”. In the prompt window that pops up, Click “**OK**”. The vehicle will lock and keep the large screen and air conditioning available.

If “**Power Off Automatically is turned on in the central control screen**” function, the vehicle automatically powers down after one hour.
9. Key Check: Carrying the mobile key in close proximity to the vehicle will automatically connect to Bluetooth, if it is not connected at all or the vehicle cannot be started in gear.



The “”issue can be resolved by clicking on the key check and using the guide.

10. Bluetooth key set-up: [See 182 page](#) is activated.

 **caution**

Vehicle authorization requires an internet connection and there may be delayed feedback. If you encounter any problems, please try again. For faster response to unlocking and locking the vehicle, please enable the following permissions for the Xiaopeng Motors App in the system permission settings:

- Non-iOS system: Bluetooth permission; Auto-start permission; Background running permission.

- iOS system: Location information-Always allowed; Background App refresh; Location services (Phone settings → Privacy → Location services).

11. Vehicle Authorization: Authorize the vehicle to another Xpeng account number, up to a maximum of 5 account numbers.



Sensereality SR

Introduction

The system detects external road conditions and the current state of the vehicle via sensors, and displays sensed road signs, other traffic participants, etc. in real time on the instrument and central control screens, creating a self-driving virtual display interface.

Instrument cluster SR interface



Real-time Virtual Reality Assist

Central control screen SR screen



4

The SR interface contains the following features:

- Driving Hazard Warning [See 68 page](#)
- The front drive away reminder [See 70 page](#)

Warnings, Cautions, and Limits

warning

SR is only an auxiliary driving function. As the driver of the vehicle, you are responsible for driving safety. Do not rely on this function to



control the vehicle, otherwise it may cause injury or even death.

warning

SR does not work properly in the following scenarios:

- The camera is restricted.
- The vehicle is driving on a large curved road or the road condition is poor.

warning

SR may have the following situations:

- An object of a certain type is displayed as another type of object.
- An object is displayed as an incorrect direction or distance.

The warnings, cautions and restrictions above do not describe all conditions that affect the normal operation of the SR.

Driving Risk Alert Sound

Introduction





The SR screen alerts you when driving in D, when the driving aid is not switched on, if the surrounding dynamic obstacle is close to the vehicle or there is a potential safety hazard.

The medium risk alert obstacle turns red, the high risk alert obstacle turns red and is accompanied by a tone.

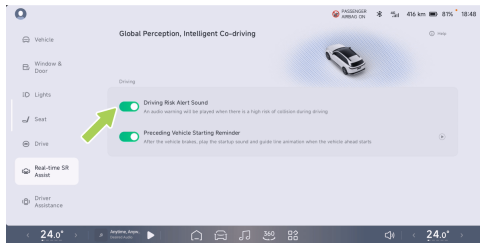

Operation



In the center control screen “→**Real-time SR Assist** screen”, The “**Driving Risk Alert Sound** can be turned on/off”.

Warnings, Cautions, and Limits

Driving Hazard Warning is for warning purposes only and it is the driver's responsibility to observe the surroundings and make decisions accordingly.

warning

Driving risk warning may not be triggered in the following situations. Including but not limited to:

- Radar or camera is limited.
- Driving on a road with a large curve.
- Driving on a road with poor conditions.

The warnings, cautions and restrictions above do not describe all the conditions that affect the normal operation of the Driving Risk Warning.



Preceding Vehicle Starting Reminder

Introduction

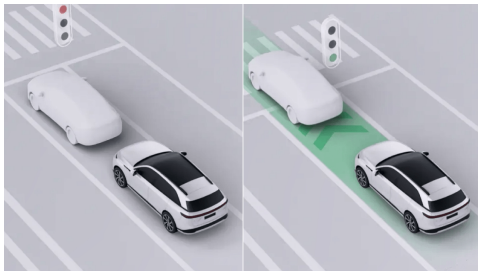

When the auxiliary drive is not switched on and in D, if the following vehicle is driven out of a certain distance on a congested road, The SR screen displays animated effects and a chime sounds to alert the driver to pull away.

Operation

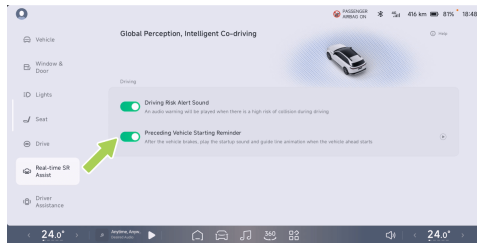

In the center control screen “ → **Real-time SR Assist screen**”, Preceding “**Vehicle Starting Reminder can be turned on/off**”in the next step.

Warnings, Cautions, and Limits

warning

The preceding vehicle start reminder may not be triggered in the following situations, including but not limited to:



Real-time Virtual Reality Assist

- There are pedestrians, bicycles, motorcycles, etc. ahead.
- There is no vehicle ahead.
- The vehicle is in a gear other than D.
- The vehicle speed is greater than 0 km/h.
- The preceding vehicle is far away from the vehicle.
- The preceding vehicle and the vehicle are stationary for a short time.

warning

The preceding vehicle start warning may be inhibited in certain circumstances, including but not limited to the following:

- Poor visibility at night.
- Poor visibility due to bad weather (such as heavy rain, heavy snow, fog, dust, etc.)
- Strong light, backlight, reflections from stagnant water, and extreme light contrast.

- Camera restricted.

The warnings, cautions and restrictions above do not describe all the conditions that affect the normal operation of the front drive away alert.



360°panorama AVM

Introduction

360°Surround Camera (AVM) captures the vehicle's surroundings via a proximity camera around the vehicle and displays it on the central control screen.

The proximity cameras are mounted above the front and rear license plate and below the left and right exterior mirrors [See 19 page](#) .

warning

AVM is an auxiliary function that can only provide reference and cannot replace the driver's observation of the surrounding environment. AVM cannot cope with all traffic, weather and road conditions. As the driver of the vehicle, you are responsible for driving safety. Please do not rely on this function to control the vehicle, otherwise it may cause injury.

Operation

Turn AVM on/off

You can turn on the AVM feature in any of the following ways:

- The AVM is automatically switched on when the vehicle gear is shifted to Reverse (R).
- Tap the taskbar  icon at the bottom of the central control screen (for example, Settings).
- Turn on the AVM via voice commands, such as saying keywords such as "Open 360".
- "When the center screen steering wheel shortcut is set to turn 360 camera on and off, This can be turned on via the steering wheel shortcut.

You can turn off the AVM feature in any of the following ways:

- In the 360 Image screen, click the upper left corner  to close the 360 Image.



Intelligent Imaging

- Turn off the AVM by voice commands, such as saying a keyword such as "Turn off 360 panorama".
- "When the center screen steering wheel shortcut is set to turn 360 camera on and off, It can be switched off via the steering wheel shortcut.

2D mode interface

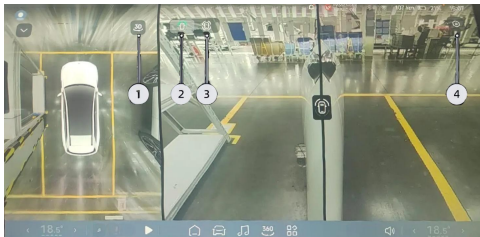

1. 3D/2D mode switch.
2. Front wheel hub view icon
3. Wheel view icon.
4. Image settings

Tap to " "jump to "Intelligent Imaging"page, The settings for image-related functions are available.

Engage the Drive screen

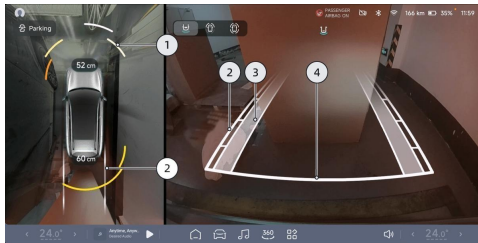

1. Radar warning

- The direction is simulated according to the distance of the obstacle.
- The distance is greater when white is displayed.
- Red is displayed with a very close distance.



- The distance from the nearest obstacle is also displayed as a numerical value in the front and rear of the vehicle.

2. Dynamic guides

- The vehicle width is represented by two thin white lines.
- The distance between the vehicle and an object is indicated by a segment tick mark line in the front/rear view.
- The distance indicated by each scale line is approximately 0.6 m, 1 m, 1.5 m from near and far.

3. Tire tracking surface

- Indicates the route the wheels are traveling.

warning

When the safety stop line contacts an obstacle, stop reversing.

4. Safety stop line

- Indicates approximately 0.3 meters from the vehicle.

3D mode interface

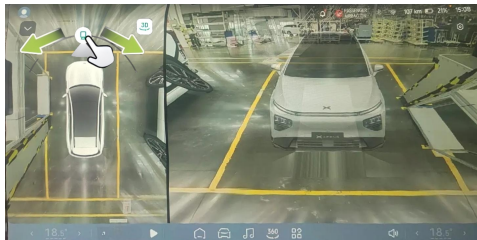

- When you switch to 3D mode, the system incorporates the 3D virtual model into the real-world image.
- Slide  or rotate the left-hand mold directly around the right-hand mold ring, all with 360° free rotation.
- No action for 5 seconds The screen automatically hides the circles and icons, and clicking on the top view area will show the circles and icons again.



- Tap on the current screen “”, Turn on “**3D Transparent Body**”, the 3D virtual model will switch to a transparent state for a direct view of the condition of the vehicle's underbody surface.
- Tap on the current screen “”, Turn on “**Transparent Chassis**”, At low vehicle speeds, the right side overhead view switches to a transparent chassis, which superimposes the virtual model on the image of the real road. Easy to observe around the body for risk of collision.

caution

The objects in the displayed image may be somewhat deformed compared to the actual objects.

warning

The transparent chassis and 3D transparent body are only used to assist in observing the bottom of the vehicle when parking and driving. Do not rely solely on this function.

Image is maintained during reverse gear shifts

In the center control screen “→**Driver Assistance→Parking**”interface, “**Reversing Image Hold can be switched on/off**”.

When the function is switched on, the 360 image changes to the front view when the gear is shifted from R to D. The 360 camera is automatically exited when the gear is switched to P or when the vehicle speed exceeds 10 km/h.

Wheel hub viewing angle changes when reversing

When reversing, you can switch between rear view, front hub view, and front and rear hub view by clicking on the center screen wheel view switch icon.



The 360 camera automatically turns off

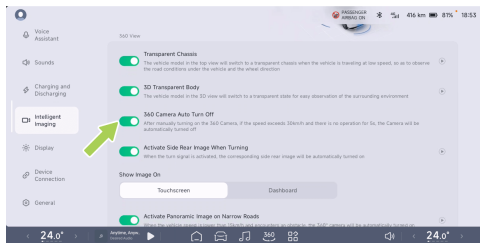

In the center control screen “ → **Intelligent Imaging**” interface, Turns “**360 Camera Auto Turn Off on/off**”.

When the function is switched on, the 360 camera is switched on manually, at a speed of more than 30 km/h and for 5 seconds without action, and the 360 camera is switched off automatically.

Warnings, Cautions, and Limits

warning

There will be some deformation between the objects in the AVM screen and the actual objects.

AVM may not work properly in the following scenarios:

- Camera restricted.
- The camera is blocked (dust, cover, etc.), or the weather conditions are bad (such as heavy rain, heavy snow, thick fog).

The warnings, cautions, and limitations above do not describe all conditions that affect the proper operation of the AVM.



3D Transparent Body

Introduction

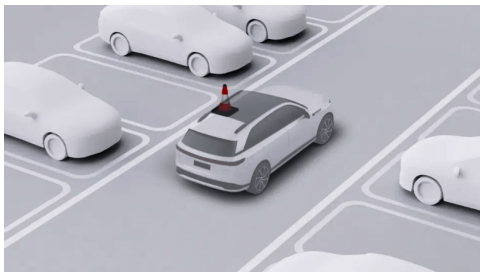

When the 3D Clear Body feature is turned on, when the AVI interface is switched to 3D display mode, the right 3D model is switched to translucent, making it easier to observe the surrounding area of the vehicle for collision risks.

warning

The 3D transparent car body is an auxiliary function that can only provide reference and

cannot replace the driver's observation of the surrounding environment. The 3D transparent car body cannot cope with all traffic, weather and road conditions. As the driver of the vehicle, you are responsible for driving safety. Please do not rely on this function to control the vehicle, otherwise it may cause injury.

Operation

Turns the 3D transparent bodywork on/off

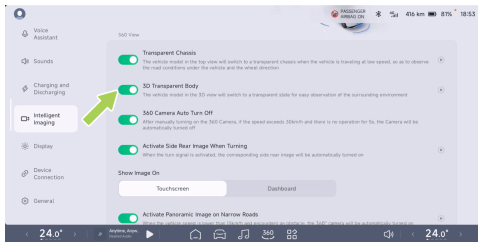

In the center control “ → Intelligent Imaging” interface, “3D Transparent Body can be turned on/off”.



Transparent Chassis

Introduction

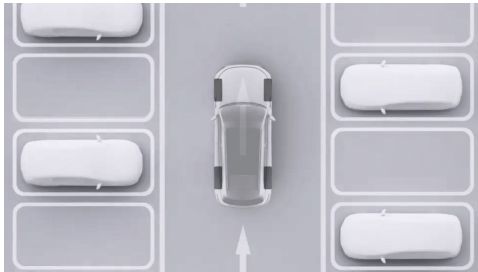

When the Clear Chassis feature is switched on, the left side overhead view will switch to the Clear Chassis at low speeds, which will overlay the virtual model onto the image of the real road. Easy to observe around the body for risk of collision.

! warning

The transparent chassis is an auxiliary function that can only provide reference and cannot replace the driver's observation of the surrounding environment. The transparent chassis cannot cope with all traffic, weather and road conditions. As the driver of the vehicle, you are responsible for driving safety. Please do not rely on this function to control the vehicle, otherwise it may cause injury.

Operation

Switch on/off the transparent chassis

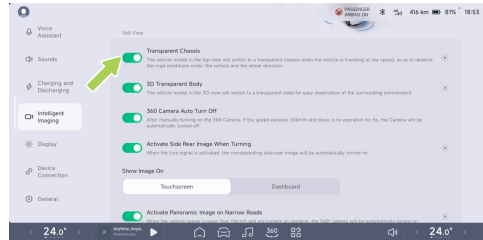



In the center control “ → **Intelligent Imaging**” interface, “**Transparent Chassis can be turned on/off**”.

Activate Panoramic Image on Narrow Roads

Introduction



The vehicle is in D, vehicle speed is less than 15 km/h and an obstruction is detected on the front and rear sides of the vehicle, the vehicle will

open a narrow channel to activate the panoramic view. Assists in driving.

warning

Activating panoramic image on narrow roads is an auxiliary function that can only provide reference and cannot replace the driver's observation of the surrounding environment. Activating panoramic image on narrow roads cannot cope with all traffic, weather and road conditions. As the driver of the vehicle, you are responsible for driving safety. Do not rely on this function to control the vehicle, otherwise it may cause injury.



Operation

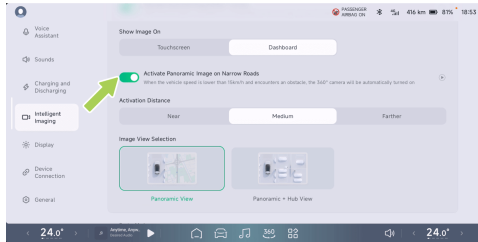

In the center control “→**Intelligent imaging**”interface, “**Activate Panoramic Image on Narrow Roads can be switched on/off**”, Different sensitivity levels can also be selected depending on driving habits.

The trigger range selection is approximately 50 cm closer, approximately 60 cm medium, and approximately 75 cm farther away.

The viewing angle can be “”either Panoramic View or “**Panoramic + Hub View**”.

Activate Side Rear Image When Turning

Introduction

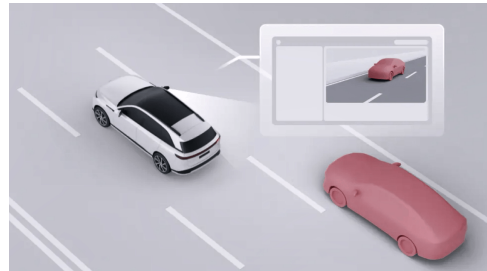

The vehicle is in D, turn on the turn signal, the vehicle automatically turns on the corresponding rear image for easy access to the rear blind spot on the side, Assists in driving.

warning

Turning to activate the rear-view camera is an auxiliary function that can only provide



reference and cannot replace the driver's observation of the surrounding environment. Activating the panoramic image on a narrow road cannot cope with all traffic, weather and road conditions. As the driver of the vehicle, you are responsible for driving safety. Please do not rely on this function to control the vehicle, otherwise it may cause injury.

Operation

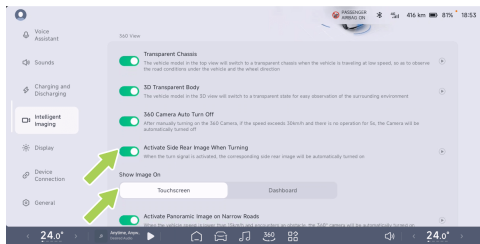

In the center control “ Intelligent imaging” interface, “**Activate Side Rear Image When Turning**” in the next step.

Tips

The steering image position is displayed on the large screen by default. If you want to display it on the instrument, you need to select the steering image position as the instrument.

The central control screen displays

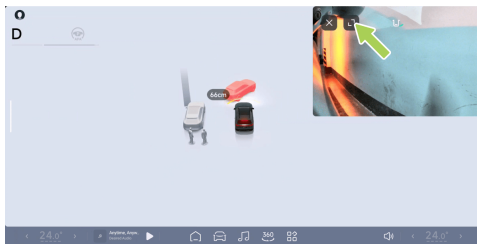

Images can be dragged to different locations and clicked on the image screen to enlarge/reduce the image.

Intelligent Imaging



Instrument interface display



Driving Recorder *

Introduction

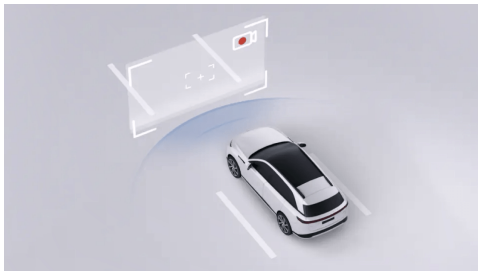

The Drive Recording feature enables video recording of the vehicle while driving and stores the video on a USB stick. Video files can be used to view past information when the user needs it, or used to assist in evidence collection in the event of an accident.

Operation

Turns Driving recorder on/off

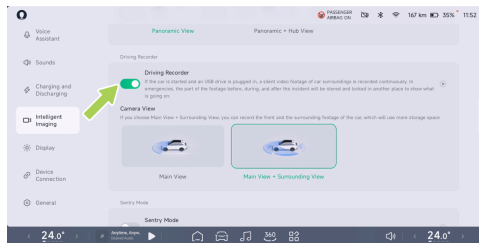



In the center control “ → Intelligent imaging” interface, to turn the “Driving Recorder on/off”.



Drive recording can be selected to record “**Main View**” or “**Main View + Surrounding View**”.

Drive Emergency Recording

Automatic triggering: With the central “**driving recording**” function on and in the recording state, The collision risk event is automatically recorded and stored by the vehicle.

Manual trigger: When CID Driving Recorder feature on. You can click the status bar  icon at the top of the CID. Click “**Emergency**” on the drop-down menu. Or tap the  icon (such as Custom Settings) in the task bar at the bottom of the central control screen to record video urgently.

Emergency recording storage location: In the central control screen “  → **DVR** → **Emergency Recording** ” Medium, Emergency recordings can be viewed and exported.

View the drive recording status

Click the  status bar icon at the top of the central control screen to view the status of the drive recording.



When driving video is on and in recording





View the drive recording status



Drive recording is not available when the USB drive needs to be checked

Export driving video to mobile phone

In the center control screen “  → **DVR** ” interface, “After selecting the images to be transferred, Tap “  ” (also in the image screen  , click in the lower right corner), Go to the File Transfer screen and follow the prompts to transfer:

1. Mobile phone connection to vehicle hot spot;



2. Open your Xpeng APP login account;
3. The central control screen selects the device to be transmitted;
4. When the mobile APP pops up, Click **“Receive”**, to transfer the files to your phone system album.

i Tips

- During file transfer, the central control screen and mobile phone app should remain in the transfer interface, and the mobile phone WiFi should be kept on to avoid disconnection.
- During the file transfer, the phone will not be able to access the Internet, and will be restored after the transfer is completed and the connection is disconnected.

Install the external storage device

Video data for drive recording is stored on the vehicle's external storage device (USB), the absence of a USB may result in the drive recording feature not being used properly.



The USB media source and Type-C power connectors at the front of the center armrest have data transmission and drive recording is available when a USB drive is inserted.

Drive recording recognizes only one USB drive at a time. Each power-on time, the USB stick that was used before power-off is preferred. If the USB drive used before power down is not recognized after 3 seconds of power up, the first USB drive recognized will be used as the active USB drive in the reading order.



Warnings, Cautions, and Limits

- Drive recording is stored for approximately 3 minutes by default, if the vehicle is locked down during recording, USB flash drive is ejected, clear the video, Formatting or switching the recording view will cause the recording to be interrupted, driving recording will save the recorded video and then rerecord a new video. The video may take less than 3 minutes.
- Avoid an emergency power down during driving recording, which will prevent the video being recorded from being saved.
- Drive video is stored in a separate USB drive, do not remove the USB drive directly. To pull out, first control the screen in the center “☰ →Driving Recorder→Manage Storage” interface, Click the “**security pop-up**”, Otherwise, the video being recorded may be lost and may result in damage to the USB drive and corrupted or lost video data. Try to avoid the use of plug adapters, docking stations, etc., which can cause loose connections.
- When driving video is on, the video is recorded in a loop, overwriting the oldest video when it is full. To ensure that important videos are not overwritten, export important videos to other devices, such as a mobile phone or computer, as necessary.
- For better technical standards, please select 32GB or above, USB 2.0 or above, write speed 10MB/s or above USB drive.
- Only USB drives with partition formats FAT16, FAT32, NTFS are supported, non-formatted USB drives are recommended to be actively formatted once. Formatting will delete all files on the USB drive, please save important data before formatting.
- The USB drive has a fixed lifetime of number of writes and is a consumable item. For example, if the USB drive has been in use for more than half a year and the video is found to be very slow to read or video is lost frequently, replace the USB drive with a new one.
- Watch the video carefully for your safety while the vehicle is in motion.



Sentry Mode

Introduction

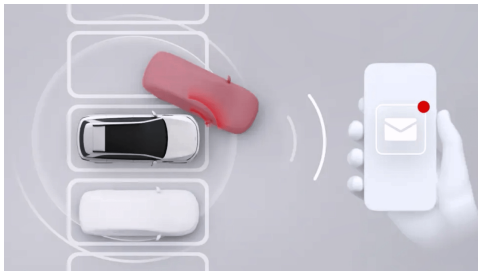

When switched on, the function will continuously monitor the vehicle's surroundings when the power is applied to the lock, alarm if a constant approach or abnormal vibration is detected (central screen illuminated and vehicle strobe) and record video before and after the risk. Effectively document potential security breaches and malicious acts of vandalism. If required, the original recording can be viewed on the CID.

You can do the following with Sentry Mode:

- Sentry mode can be set on/off via the central screen.
- View sentinel images from the central control screen.
- Sentry Mode is turned on/off via the mobile App.

Operation

Turn Sentry Mode on/off and set via the central control screen

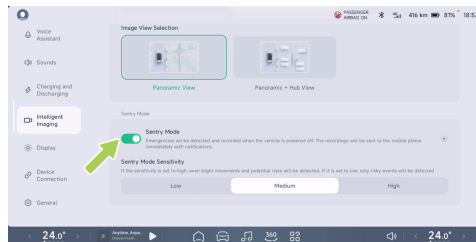



In the center control “ → **Intelligent imaging**” interface, “**Sentry Mode can be switched on/off**”.

View sentinel recordings from the CID.

In the center control screen “ → **DVR** → **Sentry Mode Recordings**” interface, to view the original sentinel video.

caution

If the system space is insufficient, the shooting may fail.

Sentry Mode is turned on/off via the mobile App.

On mobile APP “**XPENG**” interface , can turn on/off Sentry Mode.

Warnings, Cautions, and Limits

- When Sentinel mode is used, the system accesses the camera permissions to detect the vehicle's surroundings. Please use Sentinel mode in compliance with local

laws and regulations and the camera usage requirements of the location where you are located, and assume all corresponding responsibilities.

- When Sentinel mode is switched on, the vehicle security alarm may also be activated when the vehicle is subjected to an intrusion such as pry doors, prying the boot.
- Sentinel mode is only active during single-exit when switched on, and functions are automatically switched off when the vehicle is powered on.
- Sentinel mode consumes a certain amount of vehicle power, switch on if necessary.
- Battery power is continuously consumed during Sentinel mode operation and automatically exits Sentinel mode when the vehicle range is below 50 km.



Adaptive Cruise Control ACC

Introduction

ACC controls the vehicle to follow the set gap. If the car ahead stops, the car can follow, the car in front starts within 90 seconds, the car can follow pull away; if there is no follow target ahead, The will control the vehicle to travel at the set maximum cruise speed.

ACC also features Adaptive Curving (ATC), which captures the curvature of the road ahead via a camera and map, and adjusts the speed of the vehicle to improve cornering comfort and stability when ACC is on and the vehicle follows a lane line or a forward bend.

i Tips

When ACC actively slows down to keep a distance from the vehicle in front, the brake lights will light up. When ACC actively accelerates, the accelerator pedal will not move.

! warning

ACC is only an auxiliary driving function and cannot cope with all traffic, weather and road conditions. As the driver of the vehicle, you are responsible for driving safety. Please hold the steering wheel at all times, observe the road conditions, and take over in time if you encounter danger. Do not rely on this function to control the vehicle, otherwise it may cause injury or even death.

Instrument indicator lights



ACC not available.



ACC can be activated if the ACC activation conditions are met.



ACC activated.



The maximum speed limit for ACC/LCC and any function is activated.



Maximum speed limits for ACC/LCC and none active.



The system is faulty.

Operation

Activate ACC

The instrument  light up when ACC is active.



Press the selector fully down once to activate ACC, the SR screen  light up, accompanied by a voice prompt.

Tips

ACC can be activated if the following conditions are met:

- ACC-related components function normally and the field of vision is clear.
- The wipers are not in HI position.
- The brake pedal is not depressed.



- There are no security risks, including but not limited to:
 - Fasten your seat belt correctly.
 - Hold the steering wheel tightly with both hands.
 - All doors are closed.
 - Tire pressure is normal.
 - ABS, AEB and other functions are not activated.
 - Do not drive while fatigued.
- If any of the above conditions is not met, ACC cannot be activated.

Sets the maximum cruise speed

When ACC is active, the [See 140 page](#) maximum cruising speed can be set using the left steering wheel scroll wheel or the Intelligent Speed Limiter SAS introduction.

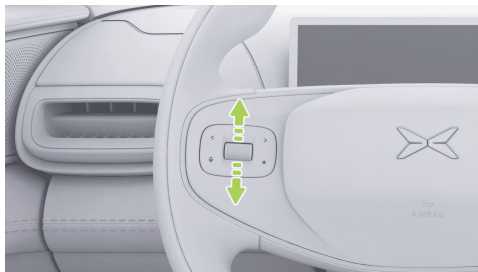

Slowly roll the scroll wheel, maximum cruise speed varies by 1 km/h, fast roll the scroll wheel, maximum cruise speed varies by 5 km/h.

Alternatively, press the accelerator pedal and push the gear selector down long enough to set the current speed to the new cruise speed, if the gear selector has not been extended. Release the accelerator pedal and the vehicle will slow down and continue cruising at the previously set speed.



Set the follow distance

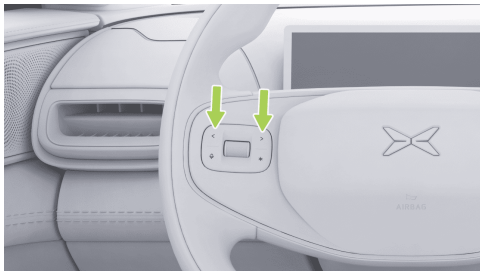

When ACC is active, the follow distance can be set via the left/right keys on the left side of the steering wheel, with 5 gears available for selection.

i Tips

When setting the following distance, the instrument will display the distance gear.

Alarm and Takeover

! warning

- If the vehicle issues a takeover request through the SR interface, voice broadcast, etc., you should take over immediately.
- If you find danger or a scene that requires takeover occurs, you should take over immediately and do not wait for the vehicle to issue a takeover request.

When ACC is active, it can be taken over by:

- Depress the accelerator pedal: Temporarily takes over the vehicle speed, increases the vehicle speed and the reverse drive selector can set the current vehicle speed to a new cruise speed, or releases the accelerator pedal. The vehicle will slow down to the previously set speed and continue cruising.
- Brake pedal pressed: ACC exits, vehicle slows down.
- Move the gear selector upwards: ACC exits, energy recovery slows the vehicle.



In addition, when ACC is active, ACC will exit if the ACC activation conditions change from satisfied to not satisfied. Pay attention to the takeover.

Warnings, Cautions, and Limits

Read all sections of this manual about ACC, you should be aware of these limitations before using the feature.

ACC is designed for driving comfort and convenience. It is not a collision warning or avoidance system and it is the driver's responsibility to remain vigilant and drive safely, and take control of the vehicle. Do not rely on the system to reduce the vehicle speed sufficiently to avoid a collision, always observe the road ahead and be prepared to take corrective action at any time, as serious injury or death may result.

It is your responsibility to determine and maintain a safe follow distance at all times and never rely solely on ACC to maintain an accurate or suitable follow distance.

warning

ACC is an auxiliary driving function and cannot cope with all traffic, weather and road conditions. Please do not use or turn on ACC in the following situations:

- Roads with twists and turns or sharp bends (such as S-bends, continuous U-bends, etc.).
- Roads with poor road conditions such as icy or slippery roads.
- When weather conditions are bad, such as heavy rain, heavy snow, dense fog, etc.
- Urban roads.

warning

ACC may not fully respond in the following special road conditions, complex road sections, bad weather or lighting conditions. Please pay attention to the environment and road conditions, be alert, keep your hands on the steering wheel at all times, and be ready to



take over the vehicle at any time, including but not limited to:

- When another vehicle suddenly moves quickly or moves in front of your vehicle at a close distance.
- When only part of the vehicle in the adjacent lane cuts in front of your vehicle (especially large vehicles such as buses and trucks).
- The vehicle ahead suddenly slows down.
- There are vehicles turning or crossing.
- When driving in a tunnel or at night, there are trucks or buses in the side lanes, or vehicles carrying extra-long goods.
- When approaching or passing a road turn, there are multiple vehicles in parallel.
- For stationary vehicles or objects (such as road obstacles), especially when the vehicle ahead leaves your lane and there is a stationary vehicle or object ahead.
- When on an uphill section of the road.

- Increase the driving speed when going downhill, and the vehicle exceeds the set speed or the road speed limit.

warning

ACC cannot fully identify and respond to the following environments and targets. Please pay attention to the environment and road conditions. When encountering the following scenarios, please take over the vehicle in time to ensure safe driving, including but not limited to:

- The following targets are encountered ahead of driving, including but not limited to:
 - People, animals.
 - Traffic light.
 - Wall, Barricade
 - Two-wheeled vehicles (bicycles, motorcycles, electric vehicles, etc.), three-wheeled vehicles.
 - Other non-vehicle objects.
 - Targets in the sensor's blind spot.



- Vehicles or objects on the other side of the ramp.
- When encountering a vehicle traveling in the opposite direction.
- When the vehicle ahead has an object protruding from its body.
- When encountering sections of road that are undergoing construction or accidents.

The warnings, cautions and restrictions above do not describe all conditions that affect the normal operation of ACC.

Lane Centering Control LCC

Introduction



The LCC is a comfortable driving aid that assists the driver in controlling the steering wheel to maximize the center of the vehicle within the current lane.

When LCC is active, ACC is simultaneously activated, the longitudinal speed and gap are controlled by ACC, which assists the driver in controlling the steering wheel. On straight and standard curvature roads with clear lane lines on



both sides, the vehicle is maximally centered in the current lane.

i Tips

- When LCC is activated, ALC can be used to assist in lane changes.
- When LCC is activated, the cruise speed and following distance can be set using the steering wheel buttons. The operation method is the same as ACC.

i Tips

- When LCC is activated, ALC can be used to assist in lane changes.
- When LCC is activated, the cruise speed and following distance can be set using the steering wheel buttons. The operation method is the same as ACC.

⚠ warning

LCC is only an auxiliary driving function and cannot cope with all traffic, weather and road conditions. As the driver of the vehicle, you

are responsible for driving safety. Please hold the steering wheel at all times and observe the road conditions. If you encounter danger, take over in time. Do not rely on this function to control the vehicle, otherwise it may cause injury or death.

Instrument indicator lights



LCC is not available.



The LCC can be activated if the LCC activation conditions are met.



LCC is activated.



LCC will delay exit.



The system is faulty.

Operation

Turn on and off

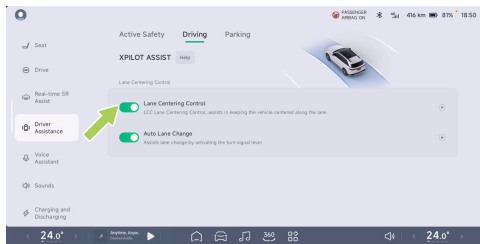

In the center control screen “ → **Driver Assistance** → **Driving**” interface, “**Lane Centering Control can be turned on/off**”.

Activate the LCC

When the LCC is active, dashboard light up



The LCC is activated by pushing the selector fully down 2 times and the SR screen light up, accompanied by a voice prompt.

Tips

LCC can be activated if the following conditions are met:

- LCC related parts function normally and the field of vision is clear.
- Lane lines are clear.
- Windshield wipers are not in HI gear.



- Brake pedal is not depressed.
- There are no safety risks, including but not limited to:
 - Fasten your seat belt correctly.
 - Hold the steering wheel tightly with both hands.
 - Close all doors.
 - Tire pressure is normal.
 - ABS, AEB and other functions are not activated.
 - Do not drive while fatigued.
- If any of the above conditions are not met, LCC cannot be activated.

Remove Hand Detection Alert

The system detects the driver's grip on the steering wheel in real time while the feature is in use. The driver has been off the hand for a certain amount of time. "A holding steering wheel alert will sound, accompanied by an audible reminder. The driver should now re-hold the steering wheel to disarm the alarm.

If the driver still does not hold the steering wheel, the system will step-by-step enhance the hand leave alert by providing visual, audible and haptic alerts, and when the continuous hand leave has reached the required time. The system will alert you to **"take over the vehicle now"**. The driver should now respond immediately to the vehicle's take-over request and take control of the vehicle's direction of travel in a timely manner. During the current driving cycle, if a manual takeover request is triggered by prolonged hands-off, the use of the assisted driving function will not be allowed for this journey, and a re-engagement of P will be required to disengage.

warning

- The hands-off detection reminder is only an auxiliary function and cannot replace the driver's judgment on the timing of takeover. The driver should concentrate on driving and respond to the reminder information issued by the system in a timely manner.



- As the driver of the vehicle, it is his responsibility to drive safely. He should abide by traffic regulations during driving, consciously keep both hands on the steering wheel throughout the driving process, and never use any means to deceive the hands-off detection system.

Alarm and Takeover

warning

- If the vehicle issues a takeover request through the SR interface, voice broadcast, etc., you should take over immediately.
- If you find danger or a scene that requires takeover occurs, you should take over immediately and do not wait for the vehicle to issue a takeover request.

The LCC adjusts the cruise speed and follow distance, refer to ACC “**setting the maximum cruise speed**”, “**Setting the follow distance**” section describes.

When the LCC is activated, it can be taken over by:

- Turning the steering wheel: Temporary take-over direction, LCC can be automatically re-activated when changing to a new lane.
- Accelerator pedal pressed: Temporary take-over of vehicle speed.
- Depress the brake pedal: Exit ACC, LCC.
- Paddle shift upwards: Exit ACC, LCC.

The LCC will be downgraded to ACC in the following scenarios, please note the takeover:

- The lane line is not clear.

If the vehicle's current state does not meet the ACC activation conditions, the LCC will exit directly.

Warnings, Cautions, and Limits

Please read all of this manual about LCC and you should be aware of these limitations before using the feature.



The LCC is designed for driving comfort and convenience, and cannot cope with sudden and dangerous situations. It is the driver's responsibility to stay alert, drive safely and take control of the vehicle at all times. Do not rely on the system for sudden emergencies. Always observe the road ahead and be prepared to take corrective action at any time, as this could result in serious injury or death.

⚠ warning

LCC cannot cope with all traffic, road conditions and weather conditions. Please do not use or turn on LCC in the following scenarios:

- Roads with changing conditions such as winding or sharp bends.
- At road merges or diverges.
- Roads under construction or correction.
- When lane lines disappear or are disconnected.
- When lane lines are blurred, disappear or covered.

- Roads where the lane lines ahead change direction dramatically, such as road divergence, lane merging, or lane width suddenly increases or decreases.
- Roads with poor road conditions such as bumps, ice or slippery roads.
- Urban roads.
- At traffic intersections.
- When the vehicle ahead is turning or a vehicle is crossing in front of the vehicle.
- Road sections where pedestrians or cyclists may appear.
- In bad weather, such as rain, snow, and fog.
- When the vehicle is in poor condition, such as abnormal four-wheel alignment, abnormal tire pressure, etc.

⚠ warning

LCC cannot fully respond in the following special road conditions, complex road sections, weather or poor lighting conditions. Please pay attention to the environment and



road conditions, be alert, keep your hands on the steering wheel at all times, and take over the vehicle at any time, including but not limited to:

Special road conditions or complex road sections:

- On a sloping road, or uphill or downhill sections.
- High-speed turns or sharp turns.
- Intersections with road barriers/curb/zebra crossings/arrows.
- No lane markings or lane markings are excessively worn or obscured, covered, or disappeared.
- Temporary adjustments or rapid changes due to road construction (e.g., lane bifurcation, crossing, or merging).
- Special lane change scenarios such as lane diversion, diversion, diversion area, lane widening, etc.

- There are words or traffic signs on the road surface or there are dense interferences such as words, traffic signs, asphalt oil, brake marks, tire marks, and water ruts in the lane.
- The lane is too wide or too narrow.
- The road boundary is separated by ice cream cones, water barriers, cement piers, etc.

Complex road conditions:

- On congested roads.
- On roads where pedestrians or cyclists may appear.
- When other vehicles are crossing in front of the vehicle.
- When a vehicle suddenly changes lanes quickly in front of the vehicle at a close distance.
- When the vehicle in front leaves the lane.
- The vehicle in front blocks the camera's field of view or covers the lane markings.



- There are large vehicles such as trucks and buses on the side or in front.

Weather conditions or poor lighting:

- Objects or landscape features cast large shadows on the roadway.
- When strong light (such as oncoming headlights or direct sunlight) obstructs the camera's view.
- The windshield obstructs the camera's view (such as fog, dust, or stickers).
- When there is a large lateral airflow or strong wind to one side of the vehicle.

Radar or camera limited:

- Radar is limited.
- Camera is limited.
- Radar or camera is blocked (dust, cover, etc.), or weather conditions are bad (such as heavy rain, heavy snow, thick fog).

! warning

LCC cannot fully identify and respond to the following environments and targets. Please pay attention to the environment and road conditions. When encountering the following scenarios, please take over the vehicle in a timely manner to ensure safe driving, including but not limited to:

- Completely rely on this system.
- Use when lane markings are unclear or lighting conditions are poor.
- Use in environments with many pedestrians, cyclists, or animals.
- Take your hands off the steering wheel.
- Take your eyes off the road.
- When there are guardrails, dividers, or curbs on one side of the road.
- Occasionally, LCC may assist the vehicle in steering when it is not needed or you do not intend to steer because lane markings are unclear or irregular or there are other lines or objects on the lane surface that resemble



lane markings. At this time, you should take over the vehicle in time.

The warnings, cautions and restrictions above do not describe all conditions that affect the proper operation of the LCC.

Auto Lane Change ALC*

Introduction



When LCC is active, the traffic lights are switched on and the ALC can assist the driver in changing lanes.

warning

ALC is only an auxiliary driving function and cannot cope with all traffic, weather and road conditions. As the driver of the vehicle, you are responsible for driving safety. Please hold the steering wheel at all times and observe the road conditions. If you encounter danger, take over in time. Do not rely on this function to control the vehicle, otherwise it may cause injury or even death.



Operation

Turn on and off

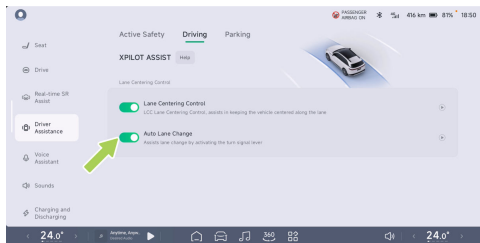

In the center control screen “ → **Driver Assistance** → **Driving**” interface, “**Auto Lane Change** can be switched on/off”.

Use ALC



1. Check the changing lane environment to verify the safety of the changing lane.
2. Switch on the corresponding side change/turn lamps.
3. ALC will assist the driver with lane changing if the ALC lane changing conditions are met and will prompt via the SR screen if the lane changing conditions are not met.

**i Tips**

- ALC can only change one lane at a time. If you need to change lanes again, please turn on the lane change lights/turn signals on the corresponding side again.
- ALC cannot change lanes across solid lines.
- After ALC is initiated, it will look for a suitable scenario to change lanes. When canceling the lane change, the SR interface will display "Lane Change Cancelled" as a prompt.
- After using ALC to complete or cancel the lane change, the lane change lights/turn signals will automatically turn off.

Alarm and Takeover**⚠ warning**

- If the vehicle issues a takeover request through the SR interface, voice broadcast, etc., take over immediately.
- If you find danger or a scene that requires takeover occurs, take over immediately and

do not wait for the vehicle to issue a takeover request.

When ALC is activated, lane change can be canceled by:

- Turn the steering wheel: Cancel the lane change and temporarily take over the direction, when the conditions are met, the LCC is reactivated.
- Depress the brake pedal: Cancel lane change and exit ACC, LCC.

Warnings, Cautions, and Limits

ALC is an assisted driving function and does not automate driving, the driver should still observe the safety of the changing lane environment at all times when ALC is active. so that in the event of a potential hazard, the vehicle can be taken over in a timely manner.

The ALC is designed for driving comfort and convenience, and cannot cope with sudden and dangerous situations. It is the driver's responsibility to stay alert, drive safely and take



control of the vehicle at all times. Do not rely on the system to respond to sudden emergencies, always observe the road ahead and be prepared to take corrective action at any time, as serious injury or death may result.

ALC may exit unexpectedly at any time for unknown reasons. Always observe road safety and be prepared to take appropriate action, and the driver is always responsible for changing lanes.

⚠ warning

Please read all the information about ALC in this manual to understand the limitations of this function, which the driver should be aware of before using the function.

- ALC cannot cope with all traffic, weather and road conditions. Do not use it in bad weather (such as rain, snow, fog) or on roads where pedestrians or cyclists may appear.
- Do not use ALC when there are vehicles in front of the vehicle or in adjacent lanes.

Using ALC at this time may cause a collision with other vehicles.

- During the use of ALC, if other vehicles change lanes at the same time and change into the same lane as the lane that the vehicle is about to change into, the function cannot avoid the risk of collision at this time. The driver must always observe the safety of the lane change environment and intervene in vehicle control in time to avoid collisions. The driver is fully responsible for safe lane changes.
- Do not use ALC when the vehicle is in poor condition, such as abnormal four-wheel positioning, abnormal tire pressure, etc.
- Do not use ALC on ramps, merges, or divergences on highways or other roads.
- Please use ALC with caution on turning sections. The system may not support lane change assistance.
- Do not use ALC on city roads or roads with changing road conditions.



- Do not use ALC on winding roads with sharp bends, bumpy, icy or slippery roads. The system cannot stably assist in lane changes under these poor road conditions.
 - ALC may occasionally identify conditions that allow lane changes as not allowing lane changes, and you need to change lanes manually.
 - On roads with heavy traffic, ALC may not be able to accurately detect the lane change environment, so use ALC with caution.
 - Do not use ALC on roads with solid lane markings or other lane change restrictions.
 - When using ALC, if other vehicles are approaching your vehicle quickly, the driver must take over immediately, as ALC cannot avoid possible collisions.
 - Do not use ALC when there are other vehicles in the blind spot behind your vehicle or in the lane change route.
- The road has sharp bends or poor road conditions, such as bumpy, slippery or icy roads.
 - On inclined roads. • Roads where pedestrians or cyclists may be present.
 - Darkness (poor lighting conditions) or poor visibility (due to heavy rain, snow, fog, etc.).
 - When strong light (such as oncoming headlights or direct sunlight) obstructs the camera's view.
 - The vehicle ahead blocks the camera's view.
 - The windshield blocks the camera's view (water mist, dust, stickers, etc.).
 - Lane markings are excessively worn or blocked or covered, old and new markings overlap, temporary adjustments due to road construction or rapid changes (for example, lane divergence, crossing or merging).
 - Objects or landscape features cast large shadows on the lane.
 - Warning cones, warning signs or other objects are placed on the road surface.



- Radar is limited.
- The radar or camera is blocked (dust, cover, etc.), or the weather conditions are adverse (such as heavy rain, heavy snow, dense fog).
- When there is a large lateral airflow or strong wind on one side of the vehicle, it will affect performance and ALC is not suitable for such weather.

The warnings, cautions and restrictions above do not describe all conditions that affect the proper operation of the ALC.



Forward/Rear Distance Monitoring

Introduction

When parking and driving at low speeds, ultrasonic radar detects the vehicle's distance from surrounding obstacles and alerts you via the SR screen and audible tones.

caution

- When a red bar is displayed, it means that the obstacle is very close to the vehicle and special attention is required.
- As the distance between the vehicle and the obstacle decreases, the frequency of the warning sound will gradually increase.

caution

- When the vehicle is in D gear, the radar will only issue an alert when the speed is less than 12 km/h; when the vehicle is in R gear, there is no speed limit for the radar alert.

- Even if the obstacle is soft (such as tall grass) and will not damage the vehicle, the radar warning will still issue a warning.

Warnings, Cautions, and Limits

warning

Radar warning may not work properly in the following scenarios:

- Radar limited.
- The vehicle is approaching an obstacle at a high speed.

The warnings, cautions, and limits above do not describe all conditions that affect the normal operation of radar alerts.



Intelligent Parking Assist APA

Introduction

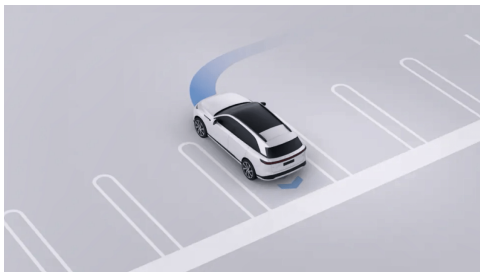

The APA assists the driver in and out of vertical, parallel and diagonal parking spaces for both wired and wireless boxes and supports the following activation methods:

- Central control screen
- Key fob
- Mobile phone key

warning

APA is only an auxiliary driving function and cannot cope with all traffic, weather and road conditions. As the driver of the vehicle, you are responsible for driving safety. Please hold the steering wheel firmly throughout the journey and observe the road conditions. If you encounter danger, take over in time. Do not rely on this function to control the vehicle, otherwise it may cause injury or even death.

Instrument indicator lights



APA is activated



APA is activated



APA is not available



Operation

Turn on and off

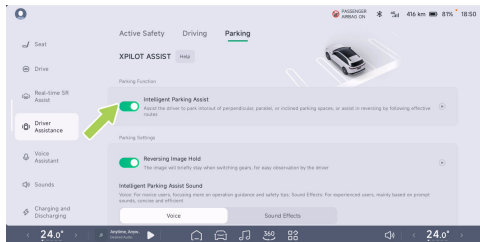

“**Driver Assistance**→**Parking on the center control screen**”interface, APA can be switched on/off.

Use APA

1. “**The Global Intelligent Drive**”interface enters Park mode using any of the following methods:
 - Auto switch. When the vehicle enters a parking environment such as a basement,

“**Global Intelligent Drive**”automatically enters parking mode.

- Press the steering wheel shortcut [See 240 page](#) .
 - Click the center screen “**I want to park**”.
 - Just say “**hello Xpeng, I'm going to park**”.
 - When the parking space icon is displayed on the SR screen, Park switches to R.
2. Drive to find the desired parking space.

i Tips

- When searching for a parking space, please keep the horizontal distance between the vehicle and the parking space within 1~2 meters.
 - When searching for a parking space, the vehicle speed should not exceed 24 kilometers per hour.
3. With the target parking space highlighted, press the brake pedal and click Select Target Parking on the central screen.
 4. The parking space can now be parked by:



- Centre screen: Tap “**Start Parking on the center screen**” and release the brake pedal.
- Key fob: Switch to P, exit, close door, long press key fob park, wait for exterior mirrors to fold, With the double flash on, long press the key fob park key.
- Phone key: Engage P, exit, close the door, open the smart parking module on the phone app, Tap “**Remote Park**”. Wait for the vehicle exterior mirrors to fold, double flash on, and then press and hold the park button. In the next step.

Tips

- After parking with the remote control key/mobile phone key, the vehicle automatically switches to P gear, locks the car and powers down.
- When parking with the remote control key/mobile phone key, the remote control key/mobile phone needs to be kept near the vehicle, otherwise the function will exit.

- When parking with the mobile phone key, you can open the door/trunk to take out items within five minutes after pausing remote parking. After taking out the items, close the door and click to continue to complete remote parking.

Alarm and Takeover

- If the vehicle issues a takeover request via SR interface, voice announcement, etc., take over immediately.
- In the event of a hazard, or in the event of a situation requiring a takeover, take over immediately and do not wait for the vehicle to issue a takeover request.
- Be sure to check that no one is in the vehicle before parking a space using the key fob/mobile app.

When APA is activated, it can be suspended by:



- Central screen parking: APA can be suspended at any time by pressing the brake pedal.
- Remote key fob parking: Release parking key on the remote key fob.
- Phone key parking: Release the park button on the phone APP page.

Once the security has been confirmed, the APA can be recovered by:

- Centre screen parking: “**Continue on top of center screen**”.
- Remote key fob parking: long press the key fob park key.
- Mobile key parking: Long press and hold the park button.

APA will exit if:

- Manually turn the steering wheel.
- Press the brake pedal to shift gears.
- APA pauses for more than 30 seconds without resuming.

- Door open, accelerator pedal pressed, brake pedal pressed causing APA to pause for 3 times.

Warnings, Cautions, and Limits

warning

Do not use APA in the following scenarios:

- The road is a slope.
- One or more ultrasonic sensors or surround view cameras are dirty or obstructed (such as mud, ice, snow, or water).
- Weather conditions are bad (such as heavy rain, heavy snow, dense fog, etc.).
- The road surface is bumpy, icy, or slippery.
- The curb is not made of stone or the curb cannot be detected.
- The road surface has height differences (such as cliff edges, high platforms, sidewalks facing the street, etc.).
- Snow chains or spare wheels are installed.



- The loaded objects protrude from the vehicle.
- Either of the left or right exterior mirrors is damaged or in an abnormal position.
- Parking spaces on narrow streets or narrow parking spaces.
- Modified vehicles or vehicle repairs at non-XPeng Motors service centers affect the normal functioning of the vehicle.

warning

In the following scenarios, APA may not be able to take safety measures and you should immediately take over the vehicle:

- When the instrument panel or central control screen sends you a takeover request.
- When APA exits unexpectedly.
- When you encounter vehicles, pedestrians and objects during parking and fail to complete automatic avoidance or braking in time.

warning

APA may occur in the following situations, please pay attention to take over:

- Obstacles at or above the height of the exterior rearview mirror.
- Overhanging, small, and narrow obstacles.
- Targets in the blind spot of the camera or radar.
- Pedestrians or animals.

The warnings, cautions, and restrictions above do not describe all conditions that affect the proper functioning of APA.

Auto Exit Parking Assist AEP

Introduction

After using the APA to introduce parking spaces, the vehicle has not been moved and can be parked out of the spaces using the following methods:



- Centre screen: With the door closed, switch to R, tap **“Start Parking Out”** on the Centre screen.
- Key fob: Long press and hold the key fob park key, wait for the vehicle exterior mirrors to fold, double-tap the key fob park key when double-flashing is on.
- Phone key: opening the phone App, Tap **“Remote Park”**. Wait for the vehicle exterior mirrors to fold, double flash on, and then press and hold the Park Out button.

i Tips

The parking exit function can only be used after logging into the car owner's account on the central control screen and turning on the super intelligent assisted parking function switch.

! warning

- AEP is only an auxiliary driving function and cannot cope with all traffic, weather and road conditions. As the driver of the

vehicle, you are responsible for driving safety. Please hold the steering wheel at all times and observe the road conditions. If you encounter danger, take over in time. Do not rely on this function to control the vehicle, otherwise it may cause injury or even death.

- APA's warnings, alarms and takeovers also apply to AEP.

Remote Vehicle Summons

Introduction

The key fob/handset key can be used to control the vehicle's forward or reverse, allowing the vehicle to enter and exit narrow spaces where it is not possible to get on and off smoothly.

i Tips

Linear Summon has an obstacle avoidance function and will automatically pause if it encounters an obstacle.



⚠ warning

The direct call feature is only a driver assistance feature and cannot handle all traffic, weather and road conditions. As the driver of the vehicle, you are responsible for ensuring driving safety. Do not rely on this feature to control other vehicles, otherwise it may result in injury or even death.

Operation

Turn on and off

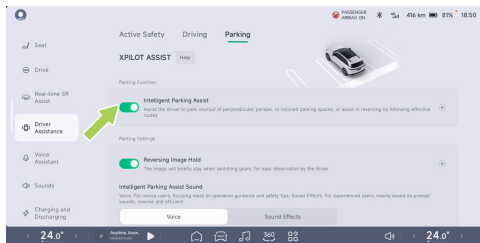

“☎ → Driver Assistance → Parking on the center control screen” interface, APA can be switched on/off.

Direct call with mobile key

1. Open the phone app, tap in “**and out of the parking space**”, the vehicle exterior mirrors fold, double flash on.
2. A long press of the switch controls the vehicle forward and backward, releasing the switch will stop the vehicle.
3. Once in or out of a parking space, tap Back to exit the function.

Alarm and Takeover

⚠ warning

If you detect danger or a scene that requires takeover occurs, you should immediately suspend the function and do not wait for the obstacle avoidance function to be triggered.

Straight Summon will exit if:

7



- Remote key fob/handset key too far from vehicle.
- Phone and vehicle Bluetooth connection disconnected.
- Triggers 3 avoidance attempts during a single use.
- The vehicle is not controlled forward or reverse for more than 30 seconds.

Warnings, Cautions, and Limits

warning

Do not use Straight call in the following scenarios:

- One or more ultrasonic sensors or surround view cameras are dirty or obstructed (such as mud, ice, snow, or water).
- Weather conditions are bad (such as heavy rain, heavy snow, dense fog, etc.).
- The road surface is bumpy, icy, or slippery.
- The road is a slope.

warning

In the following scenarios, Straight call function may not be able to take safety measures and you should take over the vehicle immediately:

- The system prompts you to take over the vehicle.
- Encountering vehicles, pedestrians and objects during parking, and not completing active avoidance or braking in time.
- Unexpected exit of Straight Direct call function.

warning

When using Straight call, do not:

- Take your eyes off the vehicle.
- Rely solely on Straight Call to park.

The warnings, cautions and restrictions above do not describe all conditions that affect the normal operation of the direct call.



Reversing Assist

Introduction

Reverse Trace is a feature that assists the driver in reversing the vehicle in its original path. When entering difficult road conditions such as dead end roads, narrow roads and other scenes, you can use track-to-track reversing to complete the rescue.

caution

Tracking reverse has obstacle avoidance function, if encountering an obstacle, it will automatically pause.

warning

Reversing Assist is only an auxiliary driving function and cannot cope with all traffic, weather and road conditions. As the driver of the vehicle, you are responsible for driving safety. Please do not rely on this function to control the vehicle, otherwise it may cause an accident.

Operation

Turn on and off

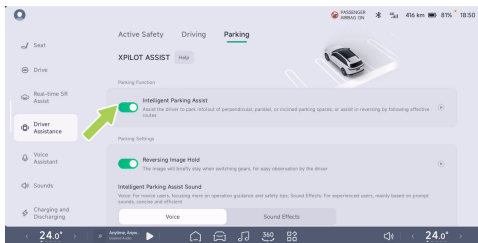

“ → **Driver Assistance** → **Parking on the center control screen**” interface, APA can be switched on/off.

Reverse with tracking

1. Driving forwards at speeds below 20km/h, the system will automatically silently learn the latest valid path.
2. Stop the vehicle and engage R.



3. Tap the center screen “**Reverse Follow→to start reverse**”button.
4. The system will automatically reverse at low speeds following a valid path.

caution

- Only the forward path in D gear at a speed lower than 20km/h may be recorded as a valid path, and the maximum length of the path can be 100m.
- Before activating Reversing Assist, if you reverse, turn the steering wheel too much, or support driving, the effective route will be cleared

Warnings, Cautions, and Limits

warning

Do not use Reversing Assist in the following scenarios:

- The road is a slope.

- One or more ultrasonic sensors or surround view cameras are dirty or obstructed (such as mud, ice, snow, or water).
- Unfavorable weather conditions (such as heavy rain, heavy snow, dense fog, etc.).
- The road surface is bumpy, icy, or slippery.
- The road surface has height differences (such as cliff edges, high platforms, sidewalks facing the street, etc.).

warning

In the following scenarios, the Reversing Assist may not be able to take safety measures, and you should take over the vehicle immediately:

- The system prompts you to take over the vehicle.
- When the tracking reverse is unexpectedly exited.
- When you encounter vehicles, pedestrians and objects during the reverse process, and fail to complete automatic avoidance or brake in time.



warning

When using Reversing Assist, you may encounter the following situations, please pay attention to the following:

- Obstacles at or above the height of the exterior rearview mirror.
- Hanging, small, and narrow obstacles.
- Targets in the blind spot of the camera or radar.
- Pedestrians or animals that suddenly approach.

warning

When using Reversing Assist, do not rely solely on tracking reverse.

The warnings, cautions and restrictions above do not describe all conditions that affect the normal operation of the trailing reversing pattern.



Forward Collision Warning FCW&AEB

Introduction

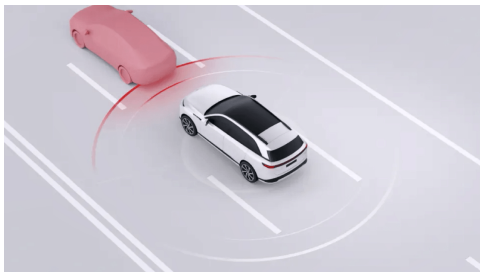

Forward Collision Warning includes Forward Collision Warning (FCW) and Autonomous Emergency Braking (AEB) to reduce the risk of a collision or reduce the speed of a collision and improve road safety.

warning

Forward Collision Warning does not operate when the vehicle is in Reverse gear.

When a collision risk is detected by the function, it is alerted via the SR interface and the tone.

warning

- For pedestrians and two-wheelers, FCW works when the vehicle's speed is about 10 to 85 km/h.
- For vehicles, FCW works when the vehicle's speed is about 10 to 150 km/h.
- When the vehicle issues a warning, the driver should take immediate action and do not wait for AEB to intervene.

If the risk increases further and the driver still does not apply the brakes or the braking force is too low, the vehicle will apply active braking to mitigate the impact injury.

warning

- For pedestrians and two-wheeled vehicles, AEB works at a speed of about 8 to 85 km/h.



- For moving, stationary or slow-moving vehicles, AEB works at a speed of about 4 to 150 km/h.
- If AEB stops the vehicle, the vehicle will remain stationary for a short time, and the driver should take over the braking as soon as possible.
- During the process of AEB intervening in the vehicle's braking, the driver's pressing the accelerator pedal may cause the braking to be interrupted.

warning

- Forward Collision Warning is an auxiliary function that does not work in all driving situations, traffic, weather and road conditions. It is not a substitute for focused driving and accurate judgment. The driver bears all responsibilities for driving safety. Always observe road conditions while driving and never rely on Forward Collision Warning to warn or avoid possible collisions. Many factors can reduce or

affect performance, resulting in unnecessary, inaccurate or invalid warnings, brake interventions or missed warnings. Relying on Forward Collision Warning to warn and avoid potential collisions may cause serious personal injury or death.

- Autonomous Emergency Braking is not designed to prevent collisions. At most, it can minimize the impact of a frontal collision by trying to reduce driving speed. Relying on Automatic Emergency Braking to avoid a collision may cause serious personal injury or death.

Instrument indicator lights



Forward Collision Warning Off



Forward collision warning fault



Operation

Turn on and off

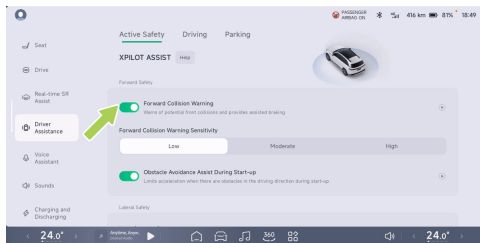

In the center control screen “**Driver Assistance**→**Active Safety**” interface, Forward “**Collision Warning can be turned on/off**”, The forward collision warning sensitivity can be set when the function is switched on.

i Tips

The forward collision warning is automatically turned on every time you drive. For your safety,

it is recommended to keep it turned on at all times.

Warnings, Cautions, and Limits

Before using Forward Collision Warning, the driver should refer to this section for guidance and limitations on the use of the function.

! warning

The forward collision warning function may be limited or not work in the following scenarios, so do not rely on it completely:

- Radar or camera is limited.
- When it is dark or visibility is poor. For example, poor lighting conditions, heavy rain, heavy snow, thick fog, etc.
- When strong light blocks the camera's view. For example, oncoming headlights or direct sunlight.
- The windshield blocks the camera's view (water mist, dust, or stickers, etc.).
- There is a car going the other way ahead.



- When the vehicle is driving on a large curved road or a road with poor conditions.
- The target suddenly appears. For example, another vehicle suddenly moves quickly or moves in front of the vehicle at a close distance.
- The target overlap rate (the overlap between the front width of the vehicle and the rear width of the vehicle in front) is insufficient.
- The driver brakes, steps on the accelerator pedal deeply, or turns the steering wheel quickly or sharply.
- There are stationary vehicles at the entrance or exit of the curve.
- When driving on a curve, the adjacent vehicle suddenly slows down.
- A vehicle overtakes from the front at the curve.
- When changing lanes, passing a stationary target on the roadside or overtaking.
- The front vehicle brakes and then changes lanes.

- The vehicle passes by a speed bump, floor drain, or iron gate in a garage.
- When the vehicle passes under an overpass, pedestrian bridge, or road sign.
- When the vehicle passes through the joints of viaducts, metal guardrails on the roadside, etc.
- There are traffic lights, water columns from sprinkler trucks, splashing water, iron pillars on the road, steel pipes in the air, floating plastic bags, cans rolling on the road, underground parking garages, highway toll stations, manhole covers, etc. in front.

The warnings, cautions and limits above do not describe all conditions that affect the proper operation of the FCW&AEB.



Blind Spot Detection BSD

Introduction



Blind Spot Safety Assist includes Blind Spot Monitor and Lane Change Alert, which monitors both sides of the vehicle's lane and alerts you when there is a risk of lane change.



Vehicle in D, vehicle speed greater than 10 km/h, if vehicle is in blind area, or fast approaching vehicle is behind blind area, The warning light in the corresponding exterior mirror is permanently lit, and the warning light in the exterior mirror changes to flash to alert you if the opposite traffic light or turn signal is turned on.

warning

Blind Spot Safety Assist is only an auxiliary driving function. It cannot cope with all traffic, weather and road conditions. It cannot replace the driver's focused driving and accurate



judgment, nor can it replace the use of interior and exterior rearview mirrors. As the driver of the vehicle, you are responsible for driving safety. Changing lanes in a safe manner is always the driver's responsibility. Do not rely on this function to control the vehicle, otherwise it may cause injury or even death.

Operation

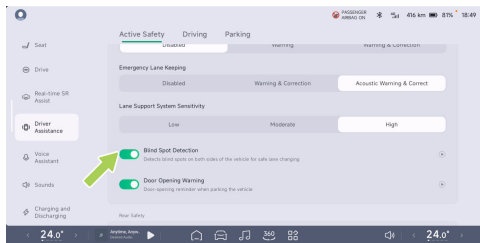

In the center control screen “ → **Driver Assistance** → **Active Safety**” interface, “**Blind Spot Detection can be turned on/off**”.

Warnings, Cautions, and Limits

warning

Blind Spot Safety Assist may not work properly in the following scenarios:

- Radar is limited.
- Sharp bends.
- When reversing.
- When there is a large moving metal object in the blind spot.

The warnings, cautions and restrictions above do not describe all conditions that affect the normal operation of the blind area safety aid.



Door Opening Warning DOW

Introduction



The DOW alerts the occupants of the vehicle when there is a risk of collision when the door is opened.

From the vehicle speed in 0 ~ 5 km/h, there are vehicles in the detection range, pedestrians, two-wheeled vehicles close at a certain speed, The DOW triggers a first-level warning, which is indicated by a constant warning light in the corresponding exterior mirror.

A secondary warning is triggered when the vehicle is still open, accompanied by an SR screen, a chime and a flashing reminder of the door ambience lighting.



The warning light for the corresponding exterior mirror is permanently on.



Proactive Security



- The door ambience lighting flashes.

warning

DOW is only an auxiliary driving function, which is designed to remind the driver and passengers to pay attention to the safety of the door opening environment when opening the door. It cannot cope with all traffic, weather and road conditions, and cannot replace the visual observation of the driver and passengers, as well as the role of the interior and exterior rearview mirrors. As the driver of the vehicle, you are responsible for

driving safety. Do not rely on this function to control the vehicle, otherwise it may cause injury or even death.

Operation

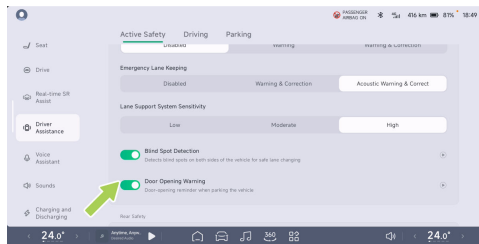

In the center control screen “ → **Driver Assistance** → **Active Safety**” interface, “**Door Opening Warning** can be turned on/off”.



Warnings, Cautions, and Limits

warning

DOW may not work properly in the following scenarios:

- Radar is limited.
- Small targets or stationary targets.
- Targets are moving too fast or turning. For example: the target vehicle changes lanes to the rear of the vehicle, or other vehicles suddenly change lanes and appear in the monitoring area behind the vehicle.
- Other vehicles or cyclists appear behind the vehicle.
- The vehicle stops at a bend or next to a wall.

The warnings, cautions, and restrictions above do not describe all conditions that affect the proper operation of the DOW.

Rear Collision Warning RCW

Introduction



When driving, the RCW detects and alerts you to a collision hazard behind the vehicle.

When the self-driving speed is 15-160km/h, there are vehicles, pedestrians, two-wheelers approaching at a certain speed, and when there is a risk of collision, the RCW is alerted via the SR interface with a chime and the hazard warning lights are on. Alerts vehicles behind.



! warning

RCW is only an auxiliary driving function. It cannot cope with all traffic, weather and road conditions. It cannot replace the driver's focused driving and accurate judgment, nor can it replace the use of interior and exterior rearview mirrors. As the driver of the vehicle, you are responsible for driving safety. Do not rely on this function to control the vehicle, otherwise it may cause injury or even death.

Operation

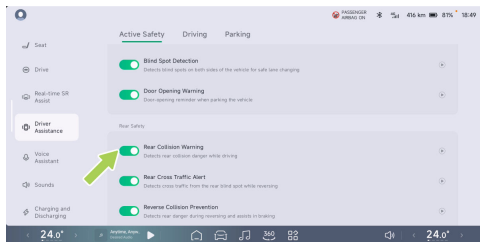

In the center control screen “ →**Driver Assistance**→**Active Safety**”interface, “**Rear Collision Warning can be turned on/off**”.

Warnings, Cautions, and Limits

! warning

RCW may not work properly in the following scenarios:

- Radar is limited.
- The detected object is moving too fast.
- There is a large moving metal object in the blind spot.
- Sharp curve.

The warnings, cautions and restrictions above do not describe all conditions that affect the proper operation of the RCW.



Reverse Collision Prevention RAEB

Introduction

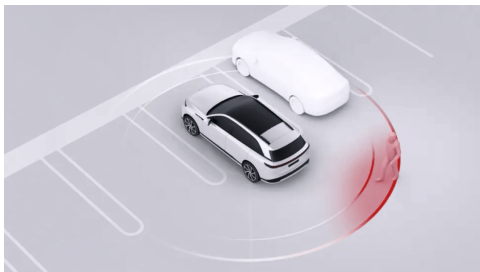

When reversing, the Driving Aids system detects if a standing or transverse pedestrian behind is within the range of the vehicle and may collide with the vehicle. In this case, the reverse collision prevention system will assist the driver with the brakes to prevent or reduce impact damage. The system also provides feedback to road traffic participants outside the vehicle via the brake lights, reminding them to avoid.

warning

RAEB is a driver assistance feature that does not work in all situations, and the system is not a substitute for the driver's attention, who must ensure safe reversing. Do not use the system when your view is obstructed and traffic conditions are difficult to observe (such as on busy roads or when crossing multiple lanes), and the system may not accurately identify cyclists and pedestrians, so you must always pay attention to your surroundings.

Function Activated

When the vehicle is in R/N gear, the vehicle speed is 1 to 12 km/h, and there are vehicles, pedestrians, and two-wheeled vehicles approaching at a certain speed within the detection range, and there is a risk of collision, the RCP will be activated and an alert will be sent via ICM or warning sound.

If the driver fails to brake in time or the dragging force is too small, the RCP will be activated to reduce or avoid injuries in a vehicle collision.



⚠ caution

After RAEB stops the vehicle, it will maintain the brakes for a period of time and the driver should take over the vehicle as soon as possible.

Operation

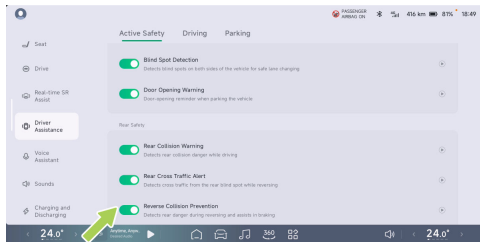

In the center control screen “ → **Driver Assistance** → **Active Safety**” interface, “**Reverse Collision Prevention can be turned on/off**” in the next step.

Warnings, Cautions, and Limits

⚠ warning

RAEB does not work properly in all situations. Unnecessary, untimely or invalid warnings may occur, or warnings may be missed, for a number of reasons, such as:

- Radar is limited.
- There is a large moving metal object in the blind spot area.
- The object to be detected is moving too fast.

The warnings, cautions and restrictions above do not describe all the conditions that affect the proper operation of RAEB.



Rear Cross Traffic Alert RCTA

Introduction

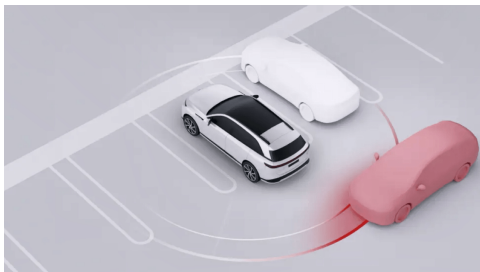

RCTA alerts the driver of traffic coming into blind spots on both sides of the rear of the vehicle when reverse vision is restricted.

Vehicle in R or N with a rearward speed of 2 to 15 km/h, vehicle, pedestrian, RCTA is activated, via the SR screen and audible tones, when the two-wheelers approach at a certain speed and there is a risk of collision.

warning

RCTA is only an auxiliary driving function. It cannot cope with all traffic, weather and road conditions. It cannot replace the driver's focused driving and accurate judgment, nor can it replace the use of interior and exterior rearview mirrors. Do not take risks because the system improves comfort. It is always the driver's responsibility to reverse in a safe manner. Do not rely on this function to control the vehicle, otherwise it may cause injury or death.



Operation

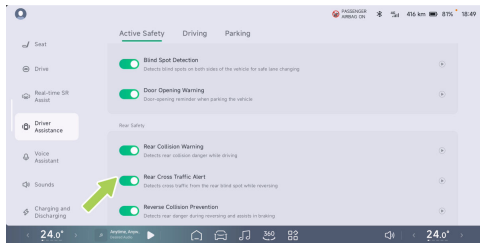

In the center control screen “ → **Driver Assistance** → **Active Safety**” interface, “**Rear Cross Traffic Alert**” can be turned on/off.

Warnings, Cautions, and Limits

warning

Do not use RCTA in the following scenarios:

- Limited field of vision.

- Complex traffic conditions, such as roads with heavy traffic or when crossing multiple lanes.

warning

RCTA may not work properly in the following scenarios:

- Radar is limited.
- The detected object is moving too fast.
- There is a large moving metal object in the blind spot.

warning

RCTA may have the following situations:

- Pedestrians and two-wheelers are not accurately identified.

The warnings, cautions and restrictions above do not describe all conditions that affect the proper operation of RCTA.



Startup Safety Assist

Introduction



Drive-away avoidance When the vehicle is moving away, an obstacle is detected in the direction of travel and the driver presses the accelerator pedal too quickly, limiting the vehicle's dynamic response. Avoid collisions with obstacles caused by electric vehicles accelerating too fast.

warning

Startup Safety Assist is only an assistive driving function and cannot replace direct visual observation. Do not over-rely on the obstacle-avoidance start assist function. When the function is activated, it only limits the acceleration of the vehicle to a certain extent. You still need to actively control the brakes to stop the vehicle, otherwise a collision will still occur. It is your responsibility to stay alert, pay attention to the vehicle starting environment, and always pay attention to other road users, otherwise it may cause serious injury or even death.



Operation

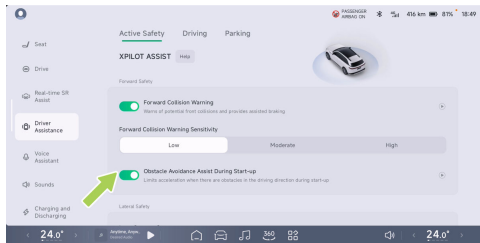

unnecessary, inaccurate or invalid warnings or missed warnings, such as:

- Radar limitations.
- Large moving metal objects in the blind spot.
- The detected object is moving too fast.

The warnings, cautions and restrictions above do not describe all conditions that affect the proper operation of the Start Up Avoidance Assist.

In the center control screen “ → **Driver Assistance** → **Active Safety**” interface, “**Obstacle Avoidance Assist During Start-up** can be turned on/off” in the next step.

Warnings, Cautions, and Limits

warning

The Startup Safety Assist feature does not always work in all situations. There are a number of reasons that may lead to



Lane Departure Assist LSS

Introduction

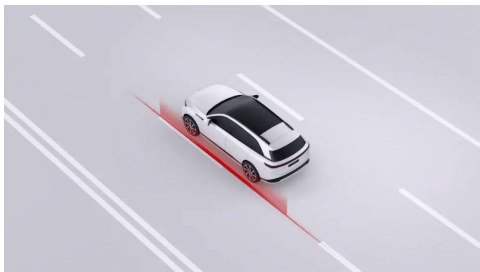

The LSS includes Lane Departure Warning (LDW), Lane Keep Assist (LKA) and Lane Emergency Keep Assist (ELK) to alert and correct unconscious lane departure or emergency avoidance of possible side impacts.

warning

LSS is only an auxiliary driving function. It cannot cope with all traffic, weather and road

conditions, and cannot replace the driver's focused driving and accurate judgment. As the driver of the vehicle, you are responsible for driving safety. Do not rely on this function to control the vehicle, otherwise it may cause injury or even death.

Only LDW is on if the alarm mode is selected, if the correction mode is selected, LDW, Both LKA and ELK are on:

- LDW: The function alerts you through the SR interface, tones and steering wheel vibration when the vehicle drifts from its lane without turning on the same direction turn signal at a speed of 60~150km/h. until the driver corrects the vehicle position.

warning

LDW only has a reminder function and cannot correct the vehicle back to the lane. Please correct the vehicle position in time when the LDW alarm sounds.



- LKA: When the vehicle drifts from the lane without turning on the same direction turn signal at 60~150km/h, the LKA alerts via the SR screen, a chime, and intervenes in the steering wheel controls to correct the vehicle back into the lane.
- ELK: When the self-driving speed is between 60 and 150 km/h, and there is an imminent collision with a roadside, oncoming or overtaking vehicle, the ELK is connected via the SR interface. An audible tone alerts and intervenes in the steering wheel controls for emergency avoidance.

caution

- When the turn signal is on or the driver has obvious turning intentions (such as turning the steering wheel quickly, braking, accelerating by pressing the accelerator pedal deeply, turning on the hazard warning lights, etc.), the lane departure assist function will not issue a warning or intervene in lane departure.

- The wipers and hazard lights will inhibit the activation of this function.

Warnings, Cautions, and Limits

warning

LSS may not work properly in the following scenarios:

Special road conditions or complex road sections:

- Lane lines are excessively worn, old and new markings overlap, temporary adjustments due to road construction or rapid changes (for example, lane bifurcation, crossing or merging).

Poor weather conditions or light environment:

- When there is a large horizontal airflow or strong wind on one side of the vehicle.
- Darkness (poor lighting conditions) or poor visibility (caused by heavy rain, heavy snow, dense fog, etc.).



- When strong light (such as oncoming headlights or direct sunlight) blocks the camera's view.
- Objects or landscape features cast large shadows on the lane.
- Lane lines cannot be recognized or are recognized incorrectly due to light reasons, such as strong light causing lane lines to reflect, bad weather, nighttime causing poor visibility or insufficient light, etc.

Camera restrictions:

- Camera restrictions.
- When the camera is blocked (dust, cover, etc.).
- When there is a vehicle in front that may block the camera's view.

warning

LSS may have the following situations:

Issue a warning or apply the brakes if there is no risk of collision.

The warnings, cautions and restrictions above do not describe all conditions that affect the proper operation of the LSS.

Traffic Sign Recognition TSR

Introduction



TSR recognizes speed limit signs on the road and, in conjunction with navigation, captures speed limit information, displays them on the SR screen and alerts you when the vehicle overruns.



Speed Limit Alert

TSR recognizes speed limit sign and electronic eye speed limits and alerts via different icons:



Speed limit sign speed limit

i Tips

The signs that TSR can recognize include: speed limit signs, variable speed limit signs, speed limit cancellation signs, regional speed limit signs, multi-lane speed limit signs, multiple speed limit signs, and highway exit ramp speed limit signs.

Over speed alarm

When the TSR has identified road speed limits:

- Manual driving, ACC/LCC Assisted driving: When the road speed limit is ≥ 60 km/h and the over speed is approximately 20%, the instrument speed limit icon flashes 3 times to alert.

! warning

TSR is only an auxiliary driving function and cannot cope with all traffic, weather and road conditions. As the driver of the vehicle, you are responsible for driving safety. Do not rely on this function to control the vehicle, otherwise it may cause injury or even death.

Operation

In the center control screen “ → **Driver Assistance** → **Active Safety**” interface, “**Speed Limit Assist can be set**”.

- Speed Limit Assist Select Display, only the icon flashes the alarm.
- Speed Limit Assist Select Alarm and select Beeps On, an audible tone will be given for each change in speed limit.
- Speed Limit Assist Select Alarm and select Alarm Sound On, an audible tone will be given for each overspeed.



Warnings, Cautions, and Limits

⚠ warning

TSR may not work properly in the following scenarios:

- Radar or camera limitations.
- When road or speed limit signs have recently changed.
- When traffic signs are in poor condition.

The warnings, cautions and restrictions above do not describe all conditions that affect the proper operation of the TSR.

Speed Assistance System SAS

Introduction

SAS is able to simultaneously set the maximum cruise speed at the road speed limits recognized by the TSR.

⚠ warning

SAS is only an auxiliary driving function and cannot cope with all traffic, weather and road conditions. As the driver of the vehicle, you are responsible for driving safety. Do not rely on this function to control the vehicle, otherwise it may cause injury or even death.

Operation

Turn on and off

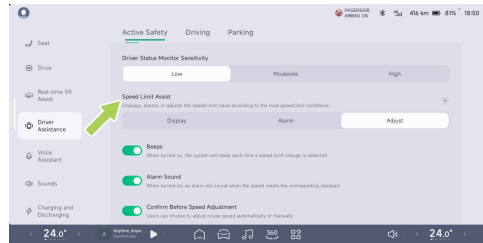



In the center control screen “ → **Driver Assistance** → **Active Safety**” interface, You can set the secondary mode for SAS.

- Speed Limit Assist Select Adjust and select Confirm Before Speed Adjustment On, if ACC/LCC is active, each change in the speed limit will require driver confirmation to perform the speed limit.
- Speed Limit Assist Select Adjust and select Confirm Before Speed Adjustment Off, if ACC/LCC is active, each change in the speed limit can be automatically executed without driver confirmation.

Warnings, Cautions, and Limits

warning

SAS may not function fully or may provide inaccurate information in the following situations:

- Cameras are limited.

- Roads or speed limits have recently changed, such as construction, regulation, etc.
- Traffic signs are in poor condition: damaged, faded, blurred, or not placed or set up as required.

The warnings, cautions, and limitations above do not describe all conditions that affect the proper functioning of SAS.



Driver Monitoring Camera DSM

Introduction



The DSM monitors the driver's status while the vehicle is moving and provides warnings if the driver shows a state of distraction or fatigue.

When the driver experiences fatigue or distraction, the system will provide reminders through instrument panel text and sound. While the driver is fatigued or distracted, the system will increase the sensitivity of LDW and FCW to provide the driver more reaction time.



Traffic Accident Guidance

Introduction

If your vehicle is experiencing any of the following conditions, please contact the Xpeng Vehicle Service Centre:

- The vehicle is involved in an unexpected situation such as a collision, blisters or bottom scraping.
- Critical fault warning messages on the instrument (e.g. power battery failure, power battery overheating, motor and controller overheating, electric system failure, [See 22 page](#)).

In the event of a vehicle malfunction or accident, to draw the attention of vehicles behind you, use the Emergency Unit Emergency Unit [See 324 page](#) to follow the steps below:

1. Park the vehicle in a safe place and turn on the hazard warning lights.

2. Remove and wear the safety vest from the trunk.
3. Remove the warning triangle from the trunk and place it in a suitable position behind the vehicle.

To ensure personal safety in the event of serious accident damage to the vehicle, note the following warnings:

- Do not touch the high voltage harness and all high voltage components on the vehicle.
- Do not touch leaking fluids.
- Do not attempt to inspect the vehicle yourself.
- If the vehicle needs to be towed, contact the Xpeng Vehicle Service Centre.
- If the vehicle is foamed, a second power up is prohibited and a short circuit within the power battery may occur. To ensure personal safety and avoid secondary damage to the vehicle, immediately contact the Xpeng Automobile Service Center to inspect the power battery system, a professional to assess the damage to the power battery.



- If the vehicle emits smoke, stay clear of the vehicle immediately and contact the Xpeng Vehicle Service Centre in a timely manner.
- If the vehicle is on fire, stay clear of the vehicle immediately and alert the alarm to inform the vehicle that it is a new energy pure electric vehicle.
- If the instrument shows a power battery system fault, stop the vehicle safely, stay clear of the vehicle and contact the Xpeng Vehicle Service Centre.
- If a person on the vehicle is injured, contact First Aid depending on the degree of injury.
- If the vehicle has a scraping bottom, collision and other accidents, the internal structure of the power battery may suffer damage, there are serious safety hazards. The power battery system needs to be checked immediately by Xpeng Automobile Service Center and the damage assessed by a specialist.

Safe use of Assisted Driving

Limitations of radar and cameras

Tips

Before using the assisted driving function each time, make sure the radar and camera surfaces are clean and unobstructed.

warning

The following situations may cause the radar/camera to fail to identify the target, delay identification, or make an error in identification:

- The radar or camera is blocked or dirty, such as by foreign objects such as ice, snow, frost, rain, fog, water, dust, etc.
- There is a fault in the radar, camera, or related components.
- Bad weather, such as rain, snow, fog, etc.
- The road is bumpy or other reasons cause the vehicle to shake.



- There are sound wave sources of the same frequency around the vehicle.
- There are objects near the vehicle that can cause the sound waves to be reflected incorrectly.
- The target detected by the radar is attached with materials that absorb sound waves, such as snowflakes, foam, cotton objects, etc.
- The volume of the detected object is too small.
- In rare special cases, false alarms may be generated for some metal guardrails, green belts, concrete walls, etc.
- When the brightness of the surrounding environment changes suddenly, such as at the entrance or exit of a tunnel.
- Large shadows cast by buildings, scenery, or large vehicles.
- The vehicle collides and the installation position of the radar or camera is changed.

- Bright light, such as oncoming headlights or direct sunlight.
- Dark surroundings, such as night, dawn, dusk, tunnels, etc.

warning

The following targets cannot be identified by radar/camera:

- Special vehicles, such as vehicles with obstructed rear ends, damaged vehicles, vehicles with irregular shapes, etc.
- When encountering animals, traffic lights, walls and other unknown obstacles on the road.
- Some metal guardrails, green belts, concrete walls, etc.
- Road test facilities, cone barrels, crash barrels, tripods, small construction signs, etc.
- Static obstacles, such as road repair facilities (traffic cones, traffic barrels, traffic columns, triangular warning signs or other roadblocks).



- Static objects, such as low-speed or stationary road sweepers, overturned accident vehicles, large rocks, tripods, isolation belts, pedestrians crossing the road, etc.

Event data logging system EDR

Introduction

This vehicle is equipped with an Event Data Logging system (EDR).

EDR automatically records vehicle operation and vehicle security system status information for a period of time before and after a vehicle event, such as:

- Vehicle speed.
- Brake pedal status.
- Longitudinal acceleration.
- Driver seatbelt status.
- The accelerator pedal position, as a percentage of the fully open position
- Power cycle in event.
- Power-up cycle on reading.
- Event data record complete status.
- The time interval between this event and the last event.
- Lateral acceleration.
- Yaw angle speed.
- Steering angle.
- The time when the event occurred.
- Gear position.
- Brake pedal position.
- Parking system status.
- Airbag deployment time.
- Seat belt pretensioner deployment time.
- Front passenger seatbelt status.
- Occupant protection system warning status.
- Tire pressure monitoring system warning status.
- Brake system warning status.
- Cruise system status.



- Anti-lock braking status.
- Autonomous emergency braking system status.
- Electronic stability control system status.
- Traction control system status.
- Sync time before event.

By collecting and analyzing the vehicle state data recorded by the EDR, it can help to understand the situation before and after the event.

The data recorded by the EDR will need to be extracted using a special diagnostic device connected to the vehicle OBD interface, if necessary contact the Xpeng Automobile Service Center for the device.

Data Usage Statement

Xpeng Motor may use EDR recorded data for fault diagnosis, product development and quality improvement. Xpeng Motor will not disclose EDR recorded data to third parties except:

- With the consent of the owner.

- To comply with the requirements of the executive and judicial organs.
- According to laws and regulations.

Seat Belt

The importance of wearing a seat belt

Proper seat belts can be worn to restrain occupants in a restricted position before a collision occurs.

In the event of a collision, proper seat belts assist other safety systems in absorbing the energy generated by the collision, reducing the inertia of forward movement and allowing the occupant to be optimally protected by the airbags. Minimize impact injuries.

warning

In the event of an accident, it is very dangerous to rely solely on airbags. Without the protection of a seat belt, if you hit the exploding airbag directly, the force generated by the body's forward movement and the



rapid expansion of the airbag will cause more serious injuries to the driver's head and chest!

warning

Drivers and passengers must wear seat belts correctly, otherwise when an accident occurs, they will rush forward and not only injure themselves but also endanger other passengers in the car.

warning

It is the driver's responsibility to ensure that all passengers wear seat belts correctly. When the central control screen prompts whether to turn off the rear seat belt unfastened reminder, please turn it off carefully.

Clean the seat belt

Pull out the seat belt, wipe it, and when finished, allow it to air dry and rewind.

caution

Do not use any type of detergent or chemical cleaner to clean the surface of the seat belt.

Replace the seat belt

If the seat belt shows signs of wear, cracks, or other damage that needs to be replaced, do not replace the seat belt yourself and must contact the Xpeng Automobile Service Center for replacement.

Warnings, Cautions, and Limits

- All persons in the vehicle must wear seat belts correctly when driving, otherwise the risk of injury or death is increased in the event of an accident.
- Do not press the seat belt on fragile or sharp objects (e.g. pens, keys, glasses, etc.), where the pressure on the seat belt may cause injury.
- When wearing a seat belt, the seat belt must be snug and untwisted, the shoulder belt must be bypassed from the middle of the



occupant's shoulder, and must be snug against the occupant's upper body. The lap portion of the belt must be as far down as possible, around the hip, and if necessary, pull down slightly on the belt body. and pull in the direction of the seat belt retraction to adjust.

- Each seat belt is intended for use by only one person in the vehicle, and it is not allowed to hold a child on his or her lap and to share the seat belt with the child.
- Avoid the seat belt from any chemicals, liquids, etc. If the seat belt cannot be retracted or locked in the latch and cannot be removed, you must contact the Xpeng Automobile Service Centre immediately for service.
- Do not add additional non-official attachments to the seat belt, including, but not limited to, additional tongue locks, webbing stops, latch extension joints, etc. The normal protection of the seat belt can be reduced or even lost.
- When not in use, the seat belt should be fully retracted and not overhang. If the seat belt cannot be fully retracted, the Xpeng

Vehicle Service Center must be contacted immediately for service.

- Do not remove or install seat belts, belt retractors, and seat belt anchors without authorization. Retrofit, disassembly, etc.

Airbags

Conditions and scenarios for expansion

The deployment of an airbag is not dependent on the vehicle's road speed at the time of the accident, but on the impact strength collected by the impact sensor at the time of the accident. Airbags may not deploy when the impact of a collision is absorbed or dispersed into the vehicle body; however, they may sometimes deploy depending on the impact conditions at the time of the accident. Therefore, airbag deployment is not judged by the degree of damage to the vehicle.

Airbags may deploy in the following situations:



- The nose hits the ground when crossing deep grooves.
- Bumped into roadside bumps, street stones, etc.
- The nose hits the ground when descending a steep hill.

The following conditions may not deploy the airbag:

- Hit a concrete post, tree or other long object.
- The tail hit under the back of a large truck, such as a truck.
- The rear of the vehicle encounters another vehicle tail.
- The vehicle is rolling over or rolling over.
- Non-frontal crashing against a wall or vehicle.

Deployed airbags and seat belts protect the occupants and reduce the risk of injury.

Impact after deployment

In the instant of airbag deployment, a loud noise is associated with the release of gas and powder,

which may irritate the skin and eyes. At this point, under the premise of safety, should escape outside the vehicle as soon as possible, if not, The window or door should be opened to allow fresh air to be drawn in.

When the powder gets into the eyes or adheres to the skin when the airbag is detonated, wash thoroughly with clean water as soon as possible and seek medical advice if you are seriously unwell.

When deployed, the air bag retracts in volume, providing a gradual damping effect for the occupants, ensuring an unobstructed view of the driver's forward vision.

Warnings, Cautions, and Limits

- An airbag can only be triggered once and any triggered airbag and any affected system components should be replaced by contacting Xpeng Automobile Service Centre as soon as possible.



- After an accident, the airbag and its associated system could fail even if it was not triggered, contact the Xpeng Automobile Service Center for service.
- The Xpeng Automobile Service Center has special tools, diagnostic equipment, service materials and qualified technical personnel. Repairs and modifications to vehicles should be carried out by Xpeng Automobile Service Centre.
- Do not use airbag components removed from end-of-life vehicles or recycled airbag components.
- Do not place anything within the primary/secondary driver airbag inflation range to prevent objects from obstructing airbag inflation in the event of a frontal impact of the vehicle.
- The front row occupants must not hold children, pets, or objects in their arms and occupy the air bag inflating space. Adults and children are subject to this requirement.
- Do not secure any objects (e.g. portable navigation units) to the front windshield above the passenger airbag.
- No objects (e.g. phone supports, ornaments, etc.) must be covered or affixed or modified on the marking surfaces of the steering wheel or front passenger airbag module.
- Do not stow objects in the front passenger seat, if the air bag explodes in case of emergency braking, the objects may be blown and injured.
- Seat covers must not be used, as this may limit the deployment of airbags and reduce the accuracy of system detection in the event of an accident.
- Do not modify the airbag cover or add parts in the vicinity of the airbag cover. The passenger must not lean his head against the door. Failure to do so could result in injury when the air curtain is deployed.
- Passengers must not place their feet, knees, or any other part of their body over or near the airbags to prevent them from working



properly or causing fractures or other injury if the airbags are deployed.

- Above or near the primary/secondary driver airbag, on the side of the front seat, above the canopy on the side of the vehicle, and on any other airbag cover that may interfere with airbag deployment. Do not load or place anything. These items can cause serious injury if the vehicle is subjected to a severe impact causing the airbags to deploy.
- Do not attempt to alter the airbag components, wiring and software as this may cause the airbag system to fail to function properly and provide the necessary protection for occupants. It may fail or start unexpectedly in the event of an accident, increasing the risk of injury.

and height of the child. Follow the instructions provided by the manufacturer of the child safety seat.

Larger children ride

If a child is too large to use a child seat, but is too small to use a standard seat belt safely, a child booster seat that meets regulations or standards can be purchased and properly used. Raising the seat cushion with a child will cushion the child so that the belt shoulder strap crosses the middle of the shoulder and lower the belt strap to the hip.

Children Passengers

Introduction

For the safety of children traveling, use a suitable child safety seat according to the age, weight



Child seat use label



warning

Do not place a rear-facing child seat on a seat protected by an airbag. Doing so may result in death or serious injury to the child in the seat.

Front passenger airbag disabling

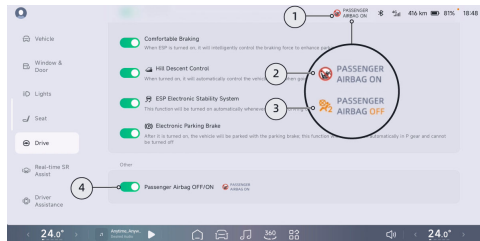

1. Front passenger airbag status indicator
2. Front passenger airbag on
3. Front passenger airbag off
4. Front passenger airbag switch

The front passenger airbag is on by default and can be turned off/on in the following two ways:

1. Tap the front passenger airbag status indicator on the status bar, then go to the switch setting interface



2. Tap “ → Drive” on the CID to enter the interface, then slide down and tap the front passenger airbag switch.

warning

- Do not place a rear-facing child seat on the seat with an active frontal airbag. Death or serious injury to the child in the seat can occur.
- Be sure to select an appropriate child safety seat for the child based on his/her age, height and weight.
- One child seat is for only one child. Never constrain multiple children into one child seat with the seat belt.

- Under no circumstances should a child or infant be carried in the occupant's arms during driving.
- Never leave a child unattended in the child seat.
- Never leave children unprotected in a vehicle. Always keep children in the correct seating position during driving. Never stand in the vehicle or kneel on the seat. If an accident occurs under these circumstances, it could be fatal to children and others.
- Any child seat that has been applied forces in an accident must be replaced.

Recommended Types of Child Seats

Both ECE-R44 and ECE-R129 standards apply to child seats in the country where the user is located

ECE-R129 classification is based on a child height.

Child status	Manufacturer	Type	Accessory
40 cm to 105 cm	Dorel Europe	Maxi-Cosi Pearl 360 & FamilyFix 360 base	ISOFIX+Support Leg



61 cm to 105 cm	HTS BeSafe	IZi Kid X3 i-Size	ISOFIX+Support Leg
100 cm to 150 cm	Britax Romer	Kidfix i-Size*	ISOFIX+Belt

*. For the best protection, it is recommended to use this child restraint system with the included backrest and be sure to attach the seat belt through Secure Guard and XP-pad.

ECE-R44 classification is based on a child weight.

Child weight	Manufacturer	Type	Accessory
22 kg-36 kg	Graco	Booster Basic	Belt

Only a child seat that is compliant might be used in the vehicle.

	Seating position						
Seating position	Front left	Front center	Front right		2nd row left (2)	2nd row center (2)	2nd row right (2)
			With front passenger airbag on	With front passenger airbag off			

Reassuring Travel



Seating position suitable for universal belted(yes /no)	No.	No.	Yes Forward facing only	Yes	Yes	Yes	Yes
I-Size seating position(yes/no)	No.	No.	No.	No.	Yes	No.	Yes
Seating position suitable for lateral fixture (L1/L2)	No.	No.	No.	No.	No.	No.	No.



Largest suitable rearward facing fixture (R1/R2X/R2/R3)	No.	No.	No.	No.	R1/ R2X /R2 /R3	No.	R1/R2X/R2/R 3
Largest suitable forward facing fixture (F1/F2X/F2/F3)	No.	No.	No.	No.	F1/ F2X /F2 /F3	No.	F1/F2X/F2/F3
Largest suitable booster fixture (B2/B3)	No.	No.	(B2/B3)*	(B2/B3)*	B2/ B3	(B2/ B3)*	B2/B3



- *Only applicable for installation with seat belt
- During the installation of the CRS, the backrest angle of seats should be adjusted reasonably to ensure that the CRS remains stable.
- During the installation of the CRS, the height of the headrest should be adjusted reasonably or the headrest should be removed to avoid interference with the CRS. Do not remove the head restraint when using a booster cushion with no. backrest
- (1): When installing a CRS on the front passenger seat, adjust the front passenger seat as high as possible to securely install the CRS
- (2): When installing a CRS on the 2nd row seat, the frontal seats can be adjusted in fore/af and height, the seatback angle can also be adjusted to ensure there is no interaction with the CRS/child.



Install the child safety seat

A child safety seat is installed via a seat belt



1. Place the child seat on the rear outboard seat and pull the seat belt fully out. Fasten and buckle the seat belt according to the child seat manufacturer's instructions.
2. With the seat belt retracted, push the child seat firmly into the seat while tightening the slack seat belt.
3. If the child seat has an upper tether, tie the tether to the seat back.

Install the child seat via ISOFIX fixing points

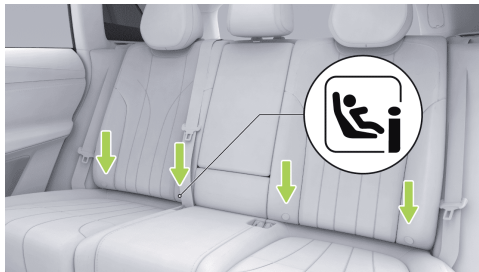

The ISOFIX anchor points are located between the rear seat back and the seat cushion, and are stamped with an ISOFIX logo above the anchor points.

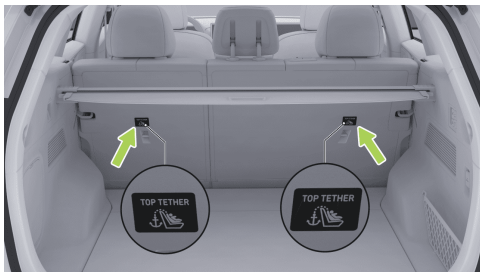

The upper anchor point is located behind the rear seat backrest on both sides.



1. Place the child safety seat on the rear outboard seat.

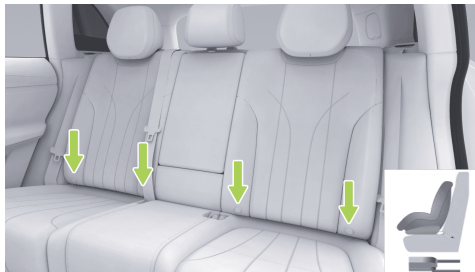



2. Insert the child safety seat lower anchorage into the ISOFIX anchor point, in accordance with the child safety seat manufacturer's instructions for use.

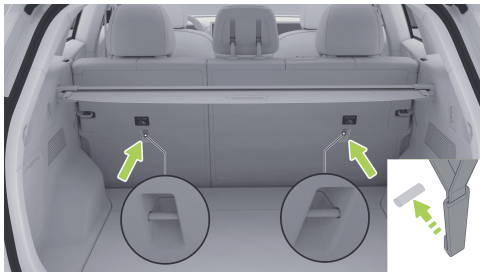

3. Pull the top strap of the child safety seat through the head restraint, to the back of the seat backrest, attach the hook loop of the strap to the anchor point and tighten the strap.

Check the child safety seat

After installing a child seat, always make sure that the child seat is not loose:

1. Secure the child seat by the belt path, try sliding the child seat from side to side and from front to rear.
2. If the child seat can move more than 2.5 cm, it is too loose, fasten the seat belt or reconnect the ISOFIX fixed child seat.
3. If it is not possible to fasten, try a different seat position or change to a different child safety seat.

warning

- Do not place a rear-facing child seat on a seat protected by an airbag, as this may result in death or serious injury to the child in the seat.
- Always select the appropriate child safety seat according to the child's age, height and weight.



- Forward-facing child safety seats can only be used if the child weighs more than 9kg and can ride independently. The spine and neck of children under two years old are not fully developed yet, so they should be protected from frontal collision injuries.
- Under no circumstances should the driver or passenger hold a child or infant in their arms while the vehicle is moving. All children should always be restrained in an appropriate child safety seat.
- Even if the child is secured in a child safety seat, do not leave him or her alone in the vehicle.
- Never allow a child to ride in a vehicle without safety protection. Always keep the child in a correct sitting position while the vehicle is moving. Never stand in the vehicle or kneel on the seat. Otherwise, in the event of an accident, it may cause fatal injuries to the child and others.
- Do not use seat belt extensions on seat belts used to install child safety seats or booster seats.
- When riding with a larger child, make sure the child's head is supported and the child seat belt is properly adjusted and secured. The shoulder belt must be positioned away from the face and neck, and the overlap must be away from the abdomen.
- Only one child should be seated in a child seat. Do not use seat belts to restrain more than one child in a child seat.
- Never attach two child safety seats to one anchor point. In the event of a collision, one anchor point may not be sufficient to secure both seats.
- The anchor points of a child restraint only bear the load from a properly installed child restraint. Under no circumstances should a child restraint be used with an adult seat belt, harness, or to attach other items or equipment.



- Always check the seat belts and tethers for damage and wear.
- Never use a child safety seat that has been modified, damaged, or involved in an accident. Inspect or replace the child seat according to the child safety seat manufacturer's instructions.
- To ensure your child is safely seated, be sure to follow all instructions detailed in this manual and the instructions provided by the child safety seat manufacturer.

Baby Guard mode

Child safety locks are fitted to both rear door and cannot be opened via the power release switch when the child safety lock is activated in Baby Guard mode, preventing children from accidentally opening the rear door. Window locks can also be opened to lock the passenger glass up and down, reducing the risk of accidents when traveling.

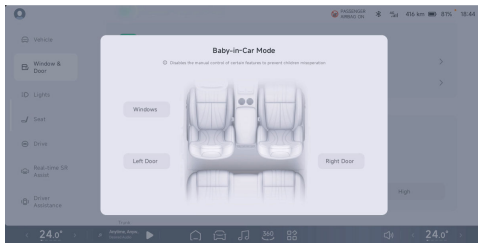

- In the Center Control Screen “ → **Window & Door** → **Baby-in-Car Mode**” interface, Window locks and child safety locks can be switched on/off.
- The child safety locks can be switched on/off via the center control shortcut panel.

Tips

- It is recommended to turn on the child safety lock when children are sitting in the back seat.
- When there are children in the car, in order to ensure safety, the passenger window

Reassuring Travel



lift should be locked to prevent children from operating the window to avoid being pinched.

warning

When the child safety lock function is turned on, the corresponding door cannot be opened from the inside. Please do not leave children alone in the car.

Alcohol Lock *

Introduction

The vehicle is equipped with an alcohol lock interface, which can be fitted with an alcohol lock on the LIN interface (the connector meets the specification 50436-4 2022).

Acoustic Vehicle Alerting System AVAS

Introduction

When the vehicle is in motion at speeds below 30 km/h, an analogue sound is emitted to alert pedestrians and vehicles nearby to safety.

Operation

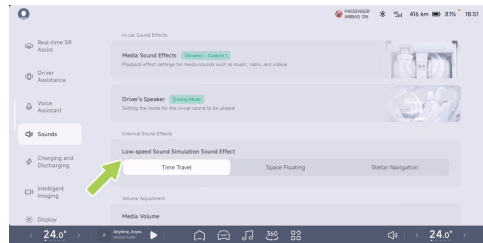

In the “ → **Sounds screen**” of the central control screen, “**Low-speed Sound Simulation Sound Effect is optional**” in the next step.



Tyre Pressure Monitoring System TPMS

Introduction

The TPMS monitors tire pressures and temperature in real time while the vehicle is moving, and alerts you when tire pressures, tire temperatures or TPMS system anomalies are detected to ensure safe driving.

- When tire pressures or TPMS are abnormal,  the instrument illuminates and a corresponding text pops up to alert: **“Low tire pressures, Reinflate in time”**, the **“tire pressure is too low, Refill immediately”**, **“tire pressure monitoring system fault, Contact Service”**, Please follow the word reminders.
- Private modification of the tire pressure monitoring system is prohibited.

Operation

The tire pressure will be automatically calibrated after each tire change, first stationary the vehicle

for more than 17 minutes before calibration, while maintaining the vehicle speed above 40 km/h for 10 minutes and avoiding reversing.

Brake Assist

Introduction

Electronic stability system ESP

ESP identifies the vehicle's driving state via sensors, such as understeer, oversteer, or drive wheel slip, and can apply targeted brake intervention or limit drive torque to reduce the risk of side slippage or tailspin. to ensure the stability of the vehicle.

Turn on and off

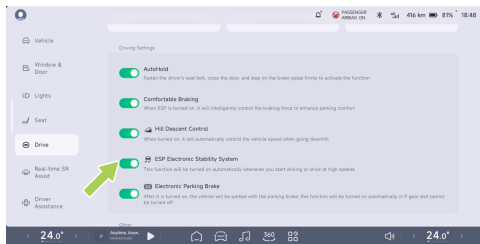

On the “**Drive screen in**” the center control screen, “**ESP Electronic Stability System can be selected on/off**” in the next step.

warning

- ESP cannot prevent accidents caused by dangerous driving or emergency steering at high speeds.
- If ESP fails, please contact the Xpeng Service Center immediately for inspection.

Anti-lock brake system ABS

The ABS prevents the wheels from locking when maximum braking force is applied. In most road conditions, the steering control of the vehicle is improved in case of emergency braking.

In the case of emergency braking, the ABS continuously monitors the speed of each wheel and adjusts the brake pressure according to the locked condition.

Brake pedal vibration may be sensed when the ABS intervenes and can be driven subjectively, depending on the road conditions, without panic.

With the ABS fault, the basic braking function is still normal and not affected by the ABS fault, but the braking distance increases.

warning

The driver should always maintain a safe distance from the vehicle in front and be aware of dangerous driving situations. Although ABS can improve stopping distances, it cannot override the laws of physics and cannot



prevent the danger of tire skidding (such as when a layer of water between the road and the tire prevents the tire from making direct contact with the road).

Emergency braking

In an emergency, fully depress the brake pedal and maintain a steady pressure. The ABS varies the brake pressure applied to each wheel according to the amount of brake force available, preventing wheel lock-up and ensuring a safe stop.

Traction control system dTCS

The drive wheel will slip when the vehicle is pulling away on slippery surfaces such as snow and ice or when accelerating sharply. The dTCS controls brake pressure and complete vehicle torque output to minimize wheel spin.

i Tips

When the vehicle is in a state of needing to be freed (such as being stuck in a muddy or snowy road), the dTCS function can control

wheel slippage while ensuring sufficient driving torque to help the vehicle get out of trouble. Rear-wheel drive models do not have this function. Please control the depth of the accelerator pedal and try to avoid keeping it fully depressed.

Brake force distribution system EBD

EBD is part of ABS, which balances the distribution of braking force to the front and rear wheels according to the load on the vehicle during normal braking.

EBD distributes the forces generated by the braking system to the four wheels, depending on the level of adhesion between each wheel and the ground, in order to achieve optimum efficiency. Significantly reduce the braking distance and keep the vehicle stable while braking, improving safety on the road.

Brake Assist EBA

In an emergency, by pressing the brake pedal quickly and holding, the EBA will produce a



greater brake pressure than it would have been under normal braking, allowing the braking system to produce the pressure required for maximum vehicle deceleration in the shortest possible time. This results in the shortest braking distance.

Hill Assist HHC

When the vehicle is pulling away from a standstill on a slope greater than 5%, the driver releases the brake pedal to depress the accelerator pedal, the HHC maintains the brake force of the driver to stop the vehicle and bring the vehicle to a standstill before moving away (the vehicle is inclined to roll away). to prevent the vehicle from rolling away.

i Tips

- HHC only applies to: when the vehicle is in D or R gear, the braking force generated before the brake pedal is pressed and released is sufficient to keep the vehicle on the slope.

- HHC can last for about 2 seconds, and the brake pressure holding time will be released in advance based on factors such as the driver and the slope.

! warning

HHC can provide braking assistance, but it cannot exceed the laws of kinematics. For safety reasons, the driver should apply the brakes in a timely manner according to the actual situation of the vehicle to prevent the vehicle from sliding down the slope and causing an accident.

Secondary collision automatic braking system MCB

In the event of a vehicle collision, the MCB is able to actively brake, reducing the probability of a secondary collision.



HDC Hill Descent Control

Introduction

HDC is a cruise function that helps the driver to descend a hill at a constant speed, reducing the fatigue of the foot that remains on the brake pedal when descending a hill.

Operation

Turns on or off in the central control screen

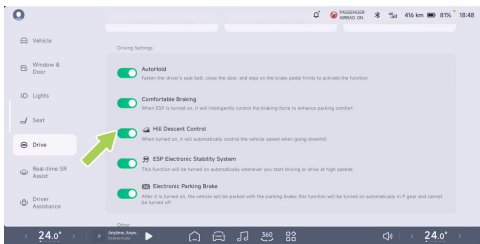

On the “ → Drive screen in” the center control screen, “**Hill Descent Control can be turned on/off**”.

The HDC function can be used when the vehicle speed is greater than 8km/h but not more than 35km/h. If the brake pedal or accelerator pedal is pressed during HDC operation, the function will exit and the driver will take over the vehicle. When the vehicle speed exceeds 60km/h, the function is fully exited and entry is inhibited.

Tips

- HDC can work on slopes with a gradient greater than or equal to 5%.
- Conditions for turning on HDC: vehicle speed is less than 35km/h; brake disc temperature is normal. ESP system is normal.

warning

HDC can actively keep the vehicle descending at a constant speed, but it cannot exceed the laws of kinematics. For safety reasons, the driver should apply the brakes in time

Reassuring Travel



according to the actual situation of the vehicle to avoid accidents caused by the vehicle going downhill too fast.



Quick car search

Introduction

Use this feature to find out where the vehicle is located when you are unable to confirm the vehicle's location.

Operation

Long distance search

When you are far away from the vehicle or do not know where the vehicle is parked, You can use the mobile app “Xpeng”interface. Check the geographic location of the vehicle.

Click on the location information to view a picture of the vehicle parking perimeter, click on the camera to view the video of the vehicle perimeter, and click on navigation to generate a search navigation path.

Find your car up close

When you are close to the vehicle (e.g. residential parking), In the mobile

Entering and exiting the vehicle

app “Xpeng”interface or “Vehicle location/map”interface, Select to be alerted by a chirping or flashing light so that you can quickly locate the vehicle.

i Tips

- Only the owner's account can view the real-time location of the vehicle.
- Poor vehicle network may cause the vehicle search function to not work properly.
- After locking the vehicle and leaving, the system will automatically collect photos of the vehicle's surroundings, desensitize and encrypt them to protect user privacy.

Unlock/lock Feedback

Introduction

When the vehicle is unlocked, the doors are unlocked synchronously, the turn signals on both sides of the vehicle flash 2 times, the horn sounds or chord music plays (if set). Eject the front door handle (if set) and unfold the exterior

Entering and exiting the vehicle



mirrors (if set) to disarm the anti-theft alarm system.

When the vehicle is locked, the doors are locked synchronously, the turn signals on both sides of the vehicle will flash 1 time, the horn will sound or chord music will play (if set). Retract the front door handles, fold the exterior mirrors (if set), close the windows (if set), activate the anti-theft alarm system.

Operation

You can set the feedback method when the vehicle is unlocked from the central screen:

- In the “ → **Window & Door screen**” of the central control screen, You can select how to unlock feedback and lock feedback separately: “**Flash Lights**”, “**Flash + Horn**”, “**Flash + Chord**”.

You can set how the door handles will open and close when unlocked from the central control screen:

- In the center control screen “ → **Window & Door**” interface, “**Pop-out Handles on Unlock**” function.

You can set how the exterior mirrors will open and close when the vehicle is locked via the central screen:

- In the center control screen “ → **Drive** → **Exterior Side Mirrors**” interface, “**Fold Side Mirrors automatically after vehicle locking can be turned on/off**” in the next step.
- Click “**Side Mirror Adjustment in the shortcut panel**”. You can use the “**side mirror**” interface to “**Fold Side Mirrors automatically after vehicle locking**” in the next step.

You can set how the windows will open and close when latched via the central control screen:

- In the center control screen “ → **Window & Door**” interface, “**Close Windows Automatically after Vehicle Locking**” in the next step.



Anti-theft alarm system

When the anti-theft system is active, any door (including the boot) or front compartment cover is opened, the anti-theft system will alarm via the horn and turn signals and will stop the anti-theft system alarm when the vehicle is unlocked.

i Tips

The anti-theft system alarm lasts for about 28 seconds. If the vehicle door (including the trunk) or the front hood is opened again, the timer will be reset.

⚠ warning

It is prohibited to modify the vehicle anti-theft system, otherwise it may cause the system to not work properly.

Entering and exiting the vehicle

NFC card key

Introduction

The NFC card key enables the vehicle to unlock, lock and start.

Operation

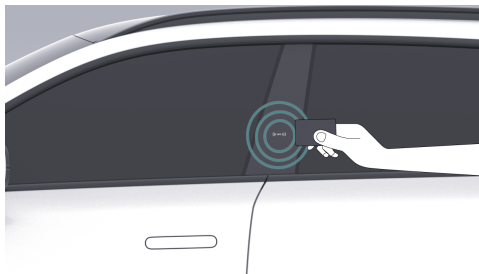

1. Unlock the door

- The vehicle is in a locked state, with the NFC card key pressed against the NFC sensing area of the B pillar of the main drive for about 1 second, the vehicle

Entering and exiting the vehicle



will appear [See 173 page](#) with an unlock feedback prompt explaining that the unlock was successful.

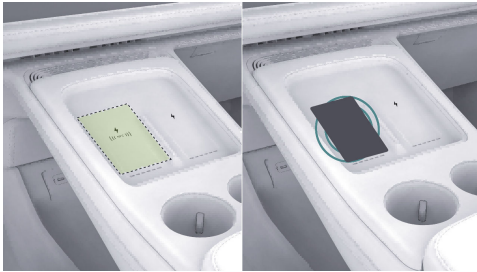

2. Start the vehicle

- Within 30 seconds of the NFC card key being flashed, the vehicle can be started by pressing the brake pedal.
- The vehicle cannot be started for more than 30 seconds, The central control screen will pop up **“to indicate that no key detected”**. Please place the NFC card key in the host mobile phone wireless charging

area (dotted area) for re-authentication.

The 30 second authentication period will restart when the card key card is detected.

Once the certification has been successful, the vehicle can be started by pressing the brake pedal and shifting gears.

3. Exit locking

- When the vehicle is unlocked and all doors (including the front compartment lid, boot) are closed, hold the NFC card key against the NFC sensing area of the B-pillar of the main drive for approximately 1 second. The vehicle will display a lock feedback prompt. Indicates successful latching.

i Tips

- Do not bend, twist or cut the NFC card key;
- Do not place the NFC card key in a high temperature place (such as the dashboard);
- When using the NFC card key to start the vehicle, do not place the mobile phone or other metal objects in the mobile phone wireless charging area;



- When using the mobile phone wireless charging function, do not place the NFC card key in the wireless charging induction area.

I-Key

Introduction

The vehicle is equipped with a smart key fob that supports key operation and keyless entry.

Operation

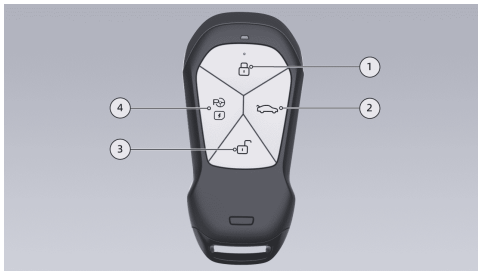

Entering and exiting the vehicle

1. Latching key

A short press of this key will prompt the vehicle to introduce a locking feedback prompt, indicating that the locking was successful.

i Tips

The vehicle can only be locked when there is no one at the wheel, the vehicle is in P gear and all doors (including the front hood and trunk) are closed.

2. trunk open and close key

Double-click to open or close the boot. Pause the open/closed boot.

3. Unlock key

A short press of the key will prompt the vehicle to unlock [See 171 page](#), indicating that the unlock was successful.

4. Park & Charge Door Open/Close key

- Double-click to open or close the charging flap.

Entering and exiting the vehicle



- Use the park related features in conjunction with the.

Replace the smart key battery

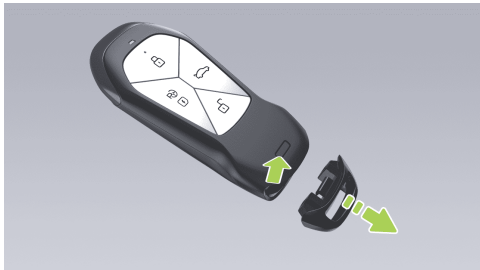

1. Press the cover unlock key A and remove the cover in the direction of the arrow B.

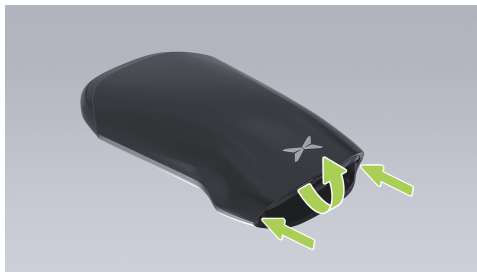

2. Using a suitable tool, pry up the sides of the back cover, then flip up the middle of the cover and remove it.



Entering and exiting the vehicle



3. Turn the key battery cover counter-clockwise in the direction of the arrow and remove the key battery cover.



4. Remove the key battery. Battery model: CR2450.
5. Install in reverse order. When installed, the key battery “+”(positive) is facing up.

Mobile App Key

Introduction

After installing the Xpeng Automobile App, you can register your phone as a key to your car, and communicate with the vehicle using Bluetooth,

Entering and exiting the vehicle



NFC technology. It helps the user to easily and safely unlock, start the vehicle and more.

The Xpeng Motors app supports the following two types of keys:

- Phone Bluetooth key

Applicable equipment: IOS, Hongmeng and Android phones.

i Tips

After activating the key, you can automatically synchronize the key by logging in with a mobile phone with a different system or uninstalling the App and reinstalling it, without having to activate it again.

- Mobile NFC key

Applicable Devices: NFC-enabled mobile phones with Hongmeng and Android.

i Tips

After activating the key, you need to set the NFC default card swiping application to "Xpeng App" before you can use it.

Phone Bluetooth key

Tap the Bluetooth key **“activation”** button in the Xpeng Motors app digital key. Once you have followed the Xpeng Motors app prompts, you can create a Bluetooth key for your phone.

The Bluetooth key is unlocked

Bluetooth key: Supports two modes of unlock operation.

- **Manual unlock:** After the phone is paired successfully with the vehicle's Bluetooth, open the Xpeng app to unlock, raise and lower the windows, open the boot, etc.
- **Automatic unlocking:** When the auto unlock switch is turned on in the Xpeng Motors app and the phone has successfully paired with the vehicle's Bluetooth, Unlocks automatically



when you bring your phone close to the vehicle, and automatically locks when you carry it away from the vehicle.

i Tips

Please do not close the Xpeng App after unlocking. Keep the Xpeng App in the background to determine the relative position of the phone and the vehicle, so as to perform automatic unlocking. To ensure normal use of the function, please be sure to enable the following permissions for the Xiaopeng App:

Android phone

- Bluetooth permission
- Auto-start permission
- Background operation permission

IOS phone

- Location information must be set to always allow
- Background App refresh

Entering and exiting the vehicle

- Location service (phone settings > Privacy > Location service)

Mobile NFC key

“”After you tap the Xpeng Automobile key activation button in the InControl App Digital Key, Once you've followed the Xpeng Motors app prompts, you can create a mobile NFC key.

i Tips

This feature is only available for phones running Android 9.0 or Hongmeng 2.0 and above and with NFC hardware.

Entering and exiting the vehicle



The NFC key unlocks/starts the vehicle

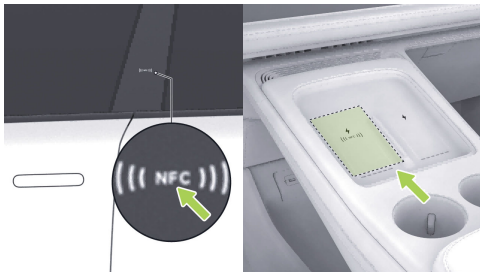

The phone NFC key is unlocked, locked, and activated in the same way as NFC card. Once the Xpeng Auto App is opened, the vehicle can be unlocked and locked by moving the phone closer to the B-pillar NFC identification area, and the vehicle can be started by completing key verification when the phone is close to the NFC identification area inside the vehicle.

i Tips

- When using the NFC key to unlock the car, you need to set the NFC default payment application to the Xpeng Motors App, otherwise NFC will not work properly.
- When using the NFC key to unlock/start the vehicle, you need to unlock the phone screen. If the phone is turned off or the screen is off, the NFC key may not work properly.
- The NFC position on the back of different phones is different. Please try to keep the back of the phone close to the NFC sensing area.

Log off the digital key

In the center control screen “ → **General** → **Safety and Privacy**” interface, Click to “**log off the digital key**”, Click to “**confirm sending in**” the pop-up prompt. Send a text message verification code to the owner's mobile number, enter the verification code Once the



verification has passed, all users will be designed from the digital key.

i Tips

After canceling the digital car key, all authorized users need to reactivate the digital car key. Please use it with caution.

Warnings, Cautions, and Limits

1. What conditions, including but not limited to, will cause the Bluetooth key to fail to unlock automatically?
 - When the phone is in low battery and low battery mode.
 - The phone does not have Bluetooth turned on.
 - The mobile system has shut down the Xpeng Motors app.
 - The Bluetooth signal is erratic and abnormally disconnected.
 - The Bluetooth signal is obscured by obstructions such as backpacks, bodies,

Entering and exiting the vehicle

walls, etc., resulting in abnormal distance measurement.

- The phone restarts, and after the system is updated, the Xpeng Motors app does not open.
- Leaving the vehicle causes Bluetooth to be disconnected when the doors, front compartment lid and boot are not fully closed.

2. What conditions, including but not limited to, will invalidate the NFC key unlock of a mobile phone?
 - When the phone is in low battery and low battery mode.
 - The phone does not have NFC enabled.
 - The default payment program for your phone is not set to Xpeng Motors.

i Tips

When the mobile phone Bluetooth key cannot unlock the car, please restart the Xpeng App first

Entering and exiting the vehicle



If the problem still cannot be solved, please go to the “**Xpeng**→**Digital Key**→**Key Check**”interface and follow the instructions to solve the connection problem.

Keyless Entry

Introduction

Keyless entry supports the following unlocking methods:

- Automatic unlocking.

Operation

Automatic unlocking

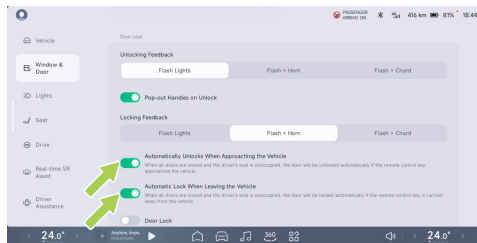

In the “**Window & Door** screen” of the central control screen, “**Automatically Unlocks When Approaching the Vehicle**” and “**Automatic Lock When Leaving the Vehicle**”.

- **Auto Unlock:** Turns on “**Automatically Unlocks When Approaching the Vehicle**”. The vehicle is automatically unlocked with the key fob close to approximately 3.5 meters from the vehicle.

10



Entering and exiting the vehicle

i Tips

After the vehicle is automatically locked, if it is still within the function sensing range, it may not be sensed and unlocked when you approach the vehicle again. In this case, you can pull the door handle or use the key to manually unlock it.

- **“Automatic Lock: Turns on Automatic Lock When Leaving the Vehicle”**. With the remote key fob away from the vehicle approximately 8 meters, the vehicle automatically locks.

i Tips

The vehicle is stationary, the doors (including the trunk) and the front hood are closed, the vehicle is in P gear, and there is no one at the wheel. The vehicle will only lock automatically when the key is away from the vehicle. Please make sure the vehicle is locked before leaving.

Warnings, Cautions, and Limits

Bluetooth antenna location



1. Both sides of the front bumper
2. Behind the front reading lamps
3. Both sides of the rear bumper

Occupants with implanted pacemakers should maintain a distance of at least 22 cm from the vehicle's Bluetooth antenna to avoid interference with the pacemaker function.

Entering and exiting the vehicle



Interior unlocked and locked

Introduction

The vehicle can be unlocked and locked in the following ways:

- Door lock switch
- Central screen door lock
- Parking is automatically unlocked

Recessed Power Door Handle

Introduction

The vehicle is equipped with a concealed power door handle, which allows you to:

- Set the door handle to deploy automatically when unlocked.
- Manually deploy the door handle.

Operation

Set the door handle to deploy automatically when unlocked

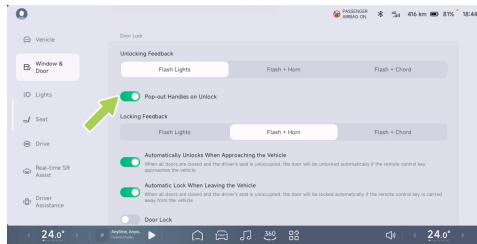

In the “ Window & Door screen” of the central control screen, “After you start Pop-out Handles on Unlock, When the vehicle is unlocked, the front door handle deploys automatically, pulling the handle opens the door.”



Manually deploy the door handle



In the “ →Window & Door screen” of the central control screen, “”After closing Pop-out Handles on Unlock, When the vehicle is unlocked, the door handles do not deploy automatically, it is necessary to press and hold the front of the door handle first. Pull the handle to open the door.

Automatically retract the door handle

- Latching Retract: When the door is latched, the door handle retracts automatically.

Entering and exiting the vehicle

- Shift retraction: The door handle retracts automatically when changing from P to N/R/D.
- Overs peed retraction: The door handle retracts automatically when the vehicle speed exceeds 3 km/h.
- Timeout Retract: When the doors (including the boot) and the front compartment cover are closed, the door handles are automatically retracted for 120 seconds without performing the retraction operation.

warning

Be careful when using the door handles to prevent your fingers, jewelry, acrylic nails, etc. from being caught by the door or door handle mechanism. Otherwise, property damage or personal injury may occur.

Tips

- When using the automatic parking function, the hidden door handle will remain in the unfolded state, and the automatic parking

Entering and exiting the vehicle



function can be paused by pulling the door handle.

- If the door handle is folded/unfolded more than 8 times within 1 minute, the anti-play mode will be triggered, the door handle will no longer move, and the function will be restored after 20 seconds.

Soft Close Doors Open/Closed

Introduction

The door can be opened/closed in the following ways:

- Recessed Power Door Handle
- Interior door handle
- Four-door E-Lock
- Mechanical key

Operation

Through the flush-operated door handle



When the vehicle is unlocked, the doors can be opened by the flush powered door handles.



Entering and exiting the vehicle

Interior door handle



- When a door is unlocked, pull either interior door handle and push outward to open the door.
- When a door is latched, either door is pulled twice in succession to open the corresponding door and the full door is unlocked when the door is opened.

Four-door E-Lock

When the door is closed to the flush position, the door latch automatically engages until the door is fully closed.

warning

Due to the large self-priming force of the door lock, it is forbidden to reach out to stop the door from closing during the self-priming process to prevent injury. If you need to stop the door from closing, you can pull the inner/outer door handle to stop the self-priming and open the door.

Entering and exiting the vehicle



Mechanical key



When the vehicle is de-energized, press the flush door handle forward to pull the door handle, fully insert the mechanical key into the locking hole and turn the door counter-clockwise to unlock. Pull the door handle to open the door.

The door can be locked directly.

i Tips

- Only the main driving door can be opened with the mechanical key.

- Please make sure that the mechanical key is fully inserted before turning the key. When unlocking, the mechanical key needs to be rotated back to the initial position before it can be pulled out. If the key cannot be turned during operation, insert the key to the bottom and continue to turn it.
- In extremely cold weather, when using the mechanical key to open the door, if the key cannot return to its position, do not forcefully remove the key, please contact the Xpeng Service Center.
- The mechanical key is provided separately with the vehicle and is not integrated with the smart key. Please store the mechanical key separately and keep it properly to avoid loss in case of emergency.

Trunk Open/Close

Introduction

The trunk can be opened/closed by:



- trunk exterior switch
- Luggage compartment interior switch
- Powered gesture boot
- Smart key fob
- Mobile App Key
- Small P-voice
- Steering wheel shortcuts (if set)
- Central control screen
 - Shortcut panel
 - Bottom taskbar (if set up)
 - Setup screen
- Emergency on switch

i Tips

When opening/closing the trunk, if there is an obstacle blocking it, the trunk will move back a certain distance

Entering and exiting the vehicle

! warning

When opening/closing the trunk, make sure there are no people or other obstacles within the opening/closing range of the trunk to prevent personal injury or vehicle damage.

Operation

trunk exterior switch



With the doors unlocked, press the boot exterior switch to open/close the boot, or to suspend an open/closed boot.

Entering and exiting the vehicle



The boot can be opened with the key in the vicinity of the boot when the vehicle is locked.

Luggage compartment interior switch



Press the trunk interior switch to close the trunk, or to suspend an open/closed trunk.

The central control screen opens/closes the boot

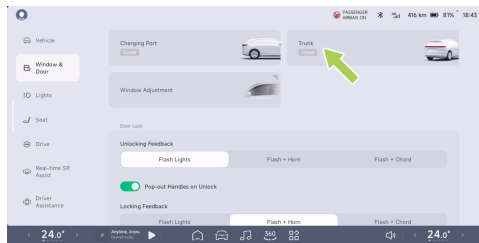

In the “🚗 → **Window & Door screen**” of the central control screen, Open/Close “**Trunk**”, Tap again during exercise to pause on/off.

Click “**Trunk**” (such as Settings) on the taskbar at the bottom of the center control screen. The boot can be opened/closed.





Entering and exiting the vehicle

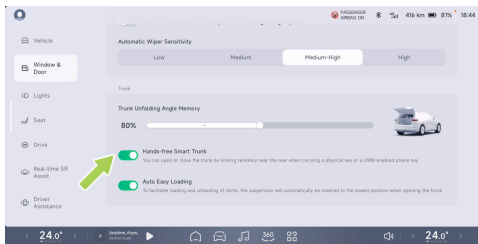

Tap the center control screen “”, Click “**Real-time VR Assist in the App Center**” Or click the taskbar “**Real-time VR Assist at the bottom of the central control screen**”(If set up), go to the full range interface and click on the icon below the 3D model to open and close the boot. Alternatively, rotate the 3D model, touch the 3D model boot area to display the hotspot icon, click the hotspot icon to open/close the boot.

Powered gesture boot



In the center control screen “→**Window & Door**”interface, Hands “**-free Smart Trunk can be switched on/off**”.



If the remote key is present in the trunk access area, the trunk can be unlocked and opened or closed by foot movement.

- The active sensing area is located on the left side of the rear bumper.
- Lift your foot up close to the rear bumper and kick your toe into the rear bumper at least 10cm, then quickly retract your foot and the trunk can be opened or closed.

i Tips

When you are in the trunk access area with the remote control key, you can use the inductive trunk function. During the trunk closing process, if the remote control key is within 30cm of the trunk, the inductive trunk cannot be activated a second time. You need to open the trunk by other means before you can use this function again.

If a valid vehicle key is within close range of the trunk, in some cases the inductive trunk function may be inadvertently triggered, triggering the trunk movement. For example, when sweeping under the rear bumper, when a large stream of water or steam is injected into the rear bumper area, or during maintenance and repairs in the trunk area, an accidentally opened boot can injure people in the trunk range and cause damage to objects.

! caution

- Do not leave a valid vehicle key within the trunk's proximity when unattended.



Entering and exiting the vehicle

- Before performing any maintenance or repair work on the vehicle, always turn off the inductive trunk function on the central control screen.
- Before each car wash, always turn off the inductive trunk function on the central control screen.

Emergency on switch

If the boot does not open, the boot can be opened by doing the following:

1. Rewind the rear seat backs and access the trunk.

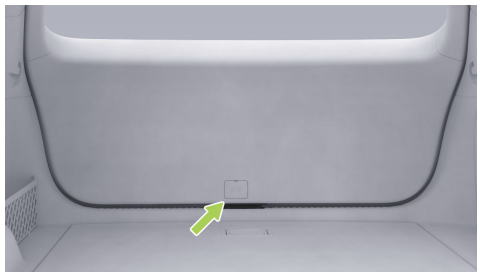

2. Open the trim cover on the emergency unlock mechanism.

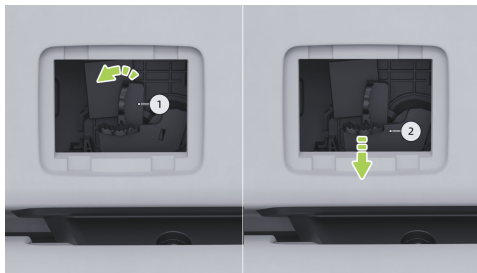

Entering and exiting the vehicle



- Emergency opening can be achieved by first pushing the lever to the left and holding, then pressing the lever 2 to unlock the boot and then pushing the boot out.

i Tips

After emergency opening, press down on the trunk to close it.

Adjust the trunk deployment angle

The vehicle supports both the central control screen and the boot interior switch to adjust the trunk deployment angle:

- In the center control screen “ → **Window & Door**” interface, Adjustable “**Trunk Unfolding Angle Memory**” in the next step.
- When the trunk is deployed to the desired angle, press and hold the trunk bottom switch until you see a flashing light prompt and the trunk deployment angle is set.

i Tips

When the switch is long pressed, if the trunk opening angle is lower than the minimum angle allowed, the trunk opening angle cannot be memorized.

trunk suspension raise/lower switch *

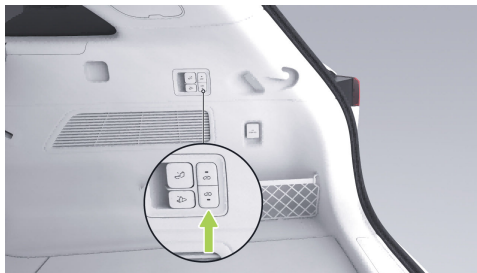

Pressing the suspension raise or lower switch in the trunk allows the trunk height to be adjusted for easy loading and unloading.



trunk anti-trap protection

If an obstacle is detected during the automatic opening or closing of the boot to restrict the movement of the boot, the opening or closing process will stop and the anti-trap function will be activated.

- The opening process is interrupted, the trunk stops and moves in reverse for a distance, ensuring that the trunk does not stay against the obstacle for a long time.
- The closing process is interrupted, the boot stops and moves in reverse for a distance.

warning

When the trunk is opened/closed automatically, make sure there is no one nearby to prevent injury from being caught.

Entering and exiting the vehicle

Welcome Mode

Introduction

In the center control “ → **window Window & Door → Welcoming Settings**” interface, The various welcome functions can be set.

- Host-driven hospitality
- Welcome assistant
- Rear reception
- Suspension approach *
- Lamp approach
- Welcome sound

Operation

Host-driven hospitality

When the host driver's seat approach feature is switched on, the host driver's seat adjusts backwards to allow you to enter and exit the vehicle when the main driver's door is opened. The seat will return to the memory position when

Entering and exiting the vehicle



the door is closed the next time you enter the vehicle.

Welcome assistant

When the passenger seat approach is switched on, the passenger seat adjusts rearward for entry and exit when the passenger door is opened. The seat will return to the memory position when the door is closed the next time you enter the vehicle.

Tips

- If the seat back angle is large, the seat may move backwards and affect the rear passengers, and the welcome function will not be activated.
- If the seat is relatively far back and it is convenient for people to get off the car, the welcome function will not be activated.

caution

Before activating the seat welcome function, make sure there are no obstacles in the seat

movement area, otherwise personal injury or vehicle damage may occur.

Suspension approach *

When the suspension approach function is switched on, the suspension height is automatically adjusted when entering or exiting the vehicle for easy access.

Rear reception

When the rear seat approach feature is switched on, the rear seats are automatically adjusted for easy entry and exit when entering or exiting the vehicle.

Lamp approach

The exterior approach lamps are automatically illuminated when approaching the vehicle 8 meters with the remote physical key.

Tips

After the welcome function is triggered, if you actively operate the lights (such as low beam,



high beam) or unlock the vehicle, the system will automatically exit the welcome function.

Welcome sound

When the welcome sound feature is on, the vehicle will play music in the set interior welcome sound once the host enters the vehicle and the main door is closed.

Power on and Power off

Introduction

The vehicle can be powered up/down by:

- Power on door.
- Latching power down
- Emergency power down.
- Apply the brake pedal to power up.
- No power will be stopped.

Entering and exiting the vehicle

Operation

Power on door

When the vehicle is unlocked, the vehicle is powered up by opening any door (excluding the boot).

Latching power down

The vehicle is powered down after locking the vehicle outside of the vehicle without a host seat.

Emergency power down





Emergency power down can be done by:

- With the vehicle stationary, press and hold the emergency off switch for 5 seconds to power down the vehicle directly.
- When stationary or at vehicle speed, press the emergency off switch 3 times in 2 seconds to power down the vehicle directly.

i Tips

If you press and hold the emergency power-off switch when the vehicle speed is set, you need to confirm it on the instrument panel. If you press it three times within 2 seconds, the power will be cut off directly regardless of whether the vehicle speed is set.

Apply the brake pedal to power up

When the vehicle is powered down, if the NFC card key, key fob or mobile phone key is in the vehicle, press the brake pedal. The vehicle is powered up.

No power will be stopped

Immobilization: When the vehicle central screen “**auto power down**” is switched off and the vehicle is powered up. Gear in P, Open the mobile app “**Xpeng**” interface. Click “**Stop**”. In the prompt window that pops up, Click “**OK**”. The vehicle will lock and keep the large screen and air conditioning available.

If “**Power Off Automatically is turned on in the central control screen**” function and the conditions for automatic power down are met, the vehicle is automatically powered down after one hour.

Automatic power down

In the center control screen “ → **General** → **Safety and Privacy**” interface, The “**Power Off Automatically**” function can be switched on/off. When the automatic power down counts down for 10 minutes, the central control screen will pop up to alert you. to “**cancel**,” The 1-hour countdown starts again when canceled.



“When the Power Off Automatically feature is turned on, The vehicle is automatically powered down when the following conditions are met at the same time.

- The car is empty.
- All doors (including boot) and front compartment lid are closed.
- The vehicle is in park.
- No operation within 1 hour of the clock.

i Tips

In addition, the vehicle will automatically power on/off when certain conditions are met.

- Power on for system upgrade.
- Power on for the autonomous driving function.

Items left behind reminder

Introduction

The Rear Seat Legacy Reminders feature provides rear seat legacy alerts by detecting

Entering and exiting the vehicle

status information such as rear seats, seat belts, etc.

! caution

This feature cannot be guaranteed to be completely accurate. Please check the rear area carefully when leaving the vehicle and never leave children, people who need help, or pets alone in the vehicle.

Operation

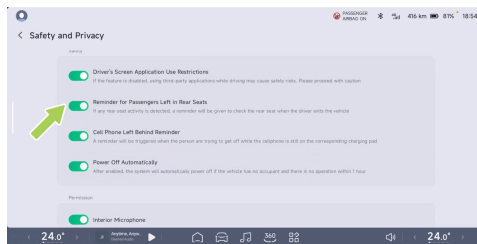

In the center control screen “ → **General** → **Safety and Privacy**” interface,

Entering and exiting the vehicle



“Reminder for Passengers Left in Rear Seats can be turned on/off” features, If rear activity is recognized when switched on, the owner will be prompted to view the rear row when exiting the vehicle.



Seat Adjustment

Introduction

The seat can be adjusted in the following ways:

- Seat switch
- CID setup screen
- Xpeng-voice

i Tips

- If the seat memory, seat welcome, seat position, central control screen adjustment and other functions cannot be used normally, you can try to initialize the operation.
- XPENG voice cannot adjust the rear seat backrest.

Operation

Seat switches adjust the host drive seat

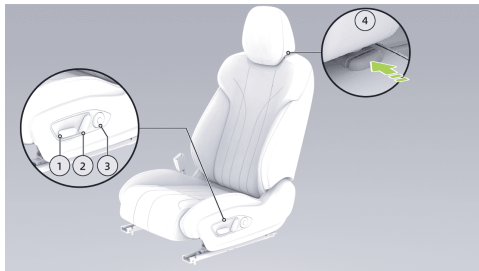

1. Seat, seat cushion adjustment switch
 - Adjust seat fore/aft: Toggle switch forward/rearward.
 - Adjust the seat height: Move the rear of the up/down toggle switch.
 - Adjust the seat cushion height: Toggle the front of the switch up/down.
2. Backrest angle adjustment switch



- Adjust the backrest angle: Toggle the top of the switch forwards/backwards.
3. Massage and calf/lumbar adjustment switch *
- Click the circle center key to toggle the seat massage on or off.
 - When adjusting the calf rest is selected in the central control screen: Press the left and right keys to adjust the calf rest.
 - When adjusting lumbar on the central control screen: Press the left and right keys to adjust lumbar fore and aft, press the up and down keys to adjust lumbar height.
4. Head restraint switch
- Adjust the height of the head restraint: Push up on the head restraint to raise it; press and hold the switch and press down on the head restraint to lower it.
 - Remove the head restraint: Press and hold the switch and pull it out upwards to remove the head restraint.

i Tips

- The headrest makes a "click" sound during adjustment, indicating that the headrest is locked in place.
- The lowest position of the headrest is not its use position. When using it, be sure to adjust the headrest to the locked position.

i Tips

If removal is necessary, adjust the seat backrest backwards to allow for easy removal of the head restraint.



Seat switches adjust the passenger seat

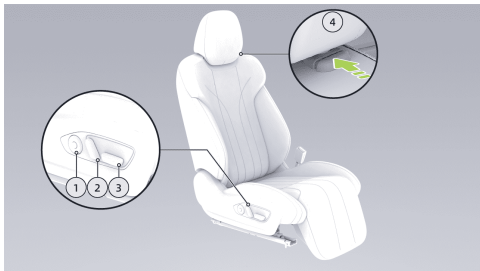

1. Massage and lumbar adjustment switch *
 - Click the circle center key to toggle the seat massage on or off.
 - Press the left/right keys to adjust the lumbar jacking height and the up/down keys to adjust the lumbar jacking position.
2. Backrest angle adjustment switch
 - Adjust the backrest angle: Toggle the top of the switch forwards/backwards.
3. Seat adjustment switch

- Adjust seat fore/aft: Toggle switch forward/rearward.
- Adjust the seat height: Move the rear of the up/down toggle switch.
- Calf rest adjustment *: Toggle the front of the switch up/down.

4. Head restraint switch

- Adjust the height of the head restraint: Push up on the head restraint to raise it; press and hold the switch and press down on the head restraint to lower it.
- Remove the head restraint: Press and hold the switch and pull it out upwards to remove the head restraint.

i Tips

- The headrest makes a "click" sound during adjustment, indicating that the headrest is locked in place.
- The lowest position of the headrest is not its use position. When using it, be



sure to adjust the headrest to the locked position.

i Tips

If removal is necessary, adjust the seat backrest backwards to allow for easy removal of the head restraint.

Both rear head restraints adjustment



Adjust the height of the head restraint: Push up on the head restraint to raise it; press and hold

the head restraint switch and press down on the head restraint to lower it.

i Tips

The head restraint makes a "click" sound during adjustment, indicating that the head restraint is locked in place.

Head restraint removal: Fold back of rear seat backrest forward, press and hold the head restraint switch, pull up and remove the head restraint.



Rear center head restraint adjustment

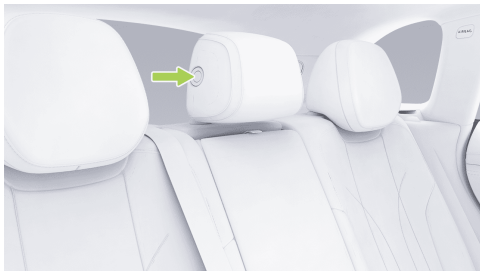

Adjust the height of the head restraint: Push up on the head restraint to raise it; press and hold the button and press down on the head restraint to lower it.

i Tips

The method for removing the middle headrest in the rear row is the same as that for the two sides.

Rear seat angle adjustment

The backrest angle can be adjusted via the rear door keys.



- Press and hold the switch fore/aft: The backrest angle begins to adjust forwards/backwards, release and stop.



Rear seat calf rest/massage switch *



- Fore-Aft key: Calf rest fore-aft adjustment.
- Up and down keys: Massage mode switch.
- Center key: Massage switch/massage intensity adjustment.

Rear seat rewind switch

The rear seat backrest supports a recline function for large luggage storage.



The right side of the trunk is equipped with a rear seat rewind switch to allow passengers to level the rear seats.

To restore the seat back, pull the seat belt out, lift the seat back up and push back to lock it.

caution

After the seat back is locked, the rear seat back adjustment switch should be used to adjust the backrest angle.



The center screen adjusts the front seats

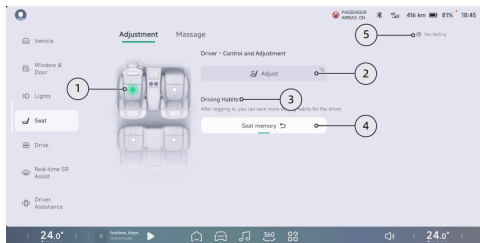

In the “ → **seat** → **adjustment screen**” of the center control screen, Make the seat position adjustment.

1. Tap “” Select the seat that requires adjustment.
2. Tap to enter the adjustment screen for the selected seat.
3. After logging in, you can enter the usage management interface, you can add your usage habits or rename your habits.

4. Tap to recall the memory position of the selected seat.

Tips

- The driver's seat is here for car usage habits. Clicking it will call up the memory positions of the driver's seat and the rearview mirror at the same time.
- When selecting a non-driver's seat, long press to rename the memory position.

5. Host drive seat key settings

- When adjusting the calf rest on the central control screen: Click the round center key to switch the seat massage on or off; press the left and right keys to adjust the calf rest.
- When adjusting lumbar in the central control screen: Click the round center key to switch the seat massage on or off; press the left and right keys to adjust lumbar fore and aft, press the up and down keys to adjust lumbar height.



Seat position memory

1. Select either the master or second drive seat on the center screen seat adjustment screen.
2. Adjust the seat position to a suitable condition.
3. Follow the central screen prompts to save.

Seat initialization

When using the seat, if the function is abnormal (e.g. keys, center screen, voice cannot adjust the seat), You can try to manually initialize the seat before using it.

Front seat initialization

1. Once the backrest angle adjustment switch is moved forward to fully forward position, it is released for 1 second;
2. Move the backrest angle adjustment switch forward again within 5 seconds and hold it for 7 seconds before releasing, the seat automatically starts initializing;
3. Wait for the seat to stop completely before using the seat.

Rear seat initialization operation

1. Press and hold the front of the rear seat backrest angle adjustment switch, and once the seat backrest is fully forward, release for 1 second;
2. Press and hold the front of the backrest angle adjustment switch again within 5 seconds for 7 seconds and then release, the seat backrest will automatically initiate the initialization;
3. Wait for the seat to stop completely before using the seat.

Warnings, Cautions, and Limits

warning

- Be careful when adjusting the seat to ensure that other passengers will not be injured when the seat moves.
- The headrest is not in the lowest position when it is in use. Do not adjust it to this position when there are passengers.



- Do not place your fingers or other parts of your body under the seat, otherwise you may be pinched by the seat.
- Do not adjust the main driver's seat while the vehicle is moving, because adjusting the seat will deviate from the correct sitting posture, which is very likely to cause casualties.
- Do not adjust the seat with the seat belt fastened to avoid the seat belt being out of normal use, causing injuries to passengers and failure of protection function.

caution

Do not place too thick foot pads or other foreign objects (such as beverage bottles, charcoal bags, etc.) under the driver's or co-driver's seats, otherwise they may be caught between the seat and the rail, hindering the seat adjustment and locking, and thus damaging the seat. It is recommended to use foot pads officially certified by Xiaopeng Motors.

Rearview Mirror

Introduction

The exterior mirrors support the following adjustment functions:

- Adjust the exterior mirror angle using the steering wheel keys
- Exterior mirror position memory
- Unfold/fold the exterior mirrors
- Reverse automatic dipping
- The exterior mirrors are automatically folded when the vehicle is locked

Operation

Access the exterior mirror adjustment screen

You can access the exterior mirror adjustment screen in any of the following ways:

- Xpeng Voice Assistant
- The center control screen shortcut panel

Driving Operation



- Bottom taskbar of the central control screen (if set up)
- On the center control screen, tap “ → Drive → Exterior Side Mirrors” in the next step.

Adjust the exterior mirror angle



When the exterior mirror adjustment screen is adjusted, the exterior mirror angle can be adjusted via the steering wheel wheels and the left and right buttons.

warning

- It is forbidden to adjust the exterior mirrors while the vehicle is in motion to prevent accidents.
- Do not manually press the exterior mirrors to adjust the tilt angle.
- It is forbidden to modify the exterior mirrors without permission.

The reverse exterior mirror automatically dips

In the exterior mirror adjustment screen, The “**left mirror automatically dips on/off (when reversing)**”, “**Automatic right mirror dip (when reversing)**” function.

When the feature is switched on, the appropriate side (with auto dip programmed) exterior mirror will automatically dip to an angle to assist reverse when the vehicle is in R.

Tips

After the rearview mirror is folded down when reversing, the angle of the rearview mirror can



still be adjusted through the rollers on both sides of the steering wheel and the left and right buttons in the exterior rearview mirror adjustment interface.

Exterior mirrors unfold/fold

1. Unfold/fold the exterior mirrors
 - In the exterior mirror adjustment screen, Tap “**Exterior Mirrors Fold**” to unfold or fold the exterior mirrors.
2. Locking vehicle automatically folds
 - In the exterior mirror adjustment screen, the automatic folding of the exterior mirrors can be switched on/off. When switched on, the exterior mirrors unfold automatically when the vehicle is unlocked and fold automatically when the vehicle is locked.

warning

When unfolding or folding the exterior mirrors, be careful not to get your fingers caught between the exterior mirrors and the mirror base.

Exterior mirror heating

The exterior mirror heating function is used to heat the left and right side exterior mirror lenses for quick drying of water or snow in rainy or snowy weather for added safety. In the air conditioning settings interface [See 233 page](#), Tap “” Heat up.

caution

When the exterior mirror heating function is on, do not touch it with your hands to avoid burns.

Automatic dimming of exterior mirrors

The light sensor detects the level of light coming from the rear of the vehicle. Based on the measured data, the exterior mirrors automatically adjust to an anti-glare state.



Warnings, Cautions, and Limits

Exterior mirrors reset

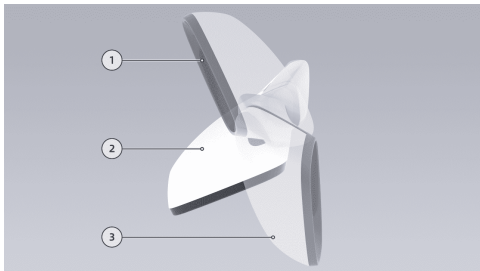

1. Fold-in status
2. Standard status
3. Back fold status

When the exterior mirrors are unfolded, accidental impact or manual push may cause the exterior mirrors to fold in or fold out, and the normal position can be restored as follows.

1. The exterior mirror unfold can be set in the center control screen by:
 - On the center screen exterior mirror adjustment screen, tap **“Unfold”**.
 - Tap Mirror **“Unfold in the center shortcut panel”**.
 - Tap **“Mirror Fold”**(e.g. Settings) on the taskbar at the bottom of the central control screen.

i Tips

When the exterior rearview mirror is in the folded state, it may be in the forward folded or other state due to accidental impact or human push. The exterior rearview mirror can be set to fold on the central control screen.

2. Manually push the mirror to the normal position.

i Tips

Before manual resetting, check whether there are foreign objects such as ice or snow on the



folding surface. Reset only after clearing the foreign objects, otherwise the folding structure of the exterior rearview mirror may be easily damaged.

Lamp Adjustment

Introduction

The lamps can be controlled by:

- Left-hand paddle
- Central control screen
 - Shortcut panel (automatic headlights on/off only)
 - Setup screen
- Xpeng voice assistant

i Tips

Xpeng voice assistant cannot turn on the high beam and turn signal.

Operation

Left-hand paddle

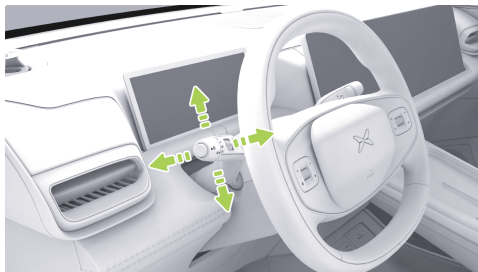

- Switching lights: Swipe the paddles up/down, automatically return when released, and the corresponding side turn lights flash 3 times.
- Turn signals: Flip the paddles up/down to the top/bottom, automatically return when released, the corresponding side turn lights flash, shift lights or steering wheel return, Turn signals off.



i Tips

When the turn signal comes on, the corresponding turn indicator light is displayed on the instrument screen, accompanied by a "click" sound.

- High beam: With low beam on, flip the stalk forward, high beam on, push again, The high beam lamps are off.
- To-pass lamps: Wash the stalk continuously rearward and release, the high beam lamps flash.

i Tips

For the driving safety of you and others, please use high beam lights reasonably.

CID setup screen

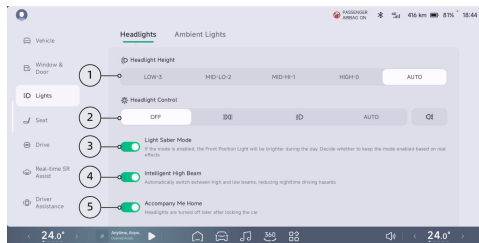

1. Headlight height:

- Headlight height can be set to suit vehicle driving and load adjustment as appropriate.

2. Headlight control:

- Off: Tap to turn off all exterior lights.
- ID Tap to switch side lamps and license plate lamps on/off.
- ID Tap to switch the low beam on/off.



caution

When the vehicle is driving in a dark environment, a second confirmation is required on the central control screen before the low beam can be turned off.

- Auto: Automatically switches dipped beam lights on/off depending on the ambient brightness of the vehicle.

Tips

The central control screen quick panel can also turn on/off the automatic headlights.

-  Tap to switch the rear fog lights on/off, or simultaneously switch on the low beam lights if the low beam lights are not illuminated.
3. Light sword mode: When you turn on, a security prompt window pops up, and after reading the security prompt carefully, Click **“OK to”** turn on the feature. Daytime highlight of the front pass light when switched on.

4. Intelligent High Beam: Click to switch Intelligent High Beam on/off [See 228 page](#) .
5. Take me home:
 - When switched on, the Follow Me Home function is activated when the vehicle is locked. A programmable delay of **“15 seconds for”**the headlights, **“30 seconds,”** **“”**Turns off after 60 seconds.

Steering assist lamps

With low beam on, the vehicle steers at low speeds (vehicle speed less than 40 km/h, steering wheel angle greater than 30°), Corresponding side steering assist lamp illuminated, increased illumination inside of bend, steering wheel back, The steering assist lamps fade out after 2 seconds of operation.



Warnings, Cautions, and Limits

Headlight height adjustment

Depending on the circumstances, the height of the headlights can be set to suit the vehicle's driving and load adjustment, see below.

Condition	Headlight height position
Driver only	Highest
Driver and one front passenger only	
There are five people in the front and rear seats	Higher
Five persons in front and rear seats with luggage in the trunk (within maximum permissible axle weights and maximum permissible weight limits)	Lower

Driver only, luggage in the trunk (within maximum permissible axle weight and maximum permissible weight limits)	Lowest
--	--------

caution

Under certain usage conditions (such as high humidity or car washing), the headlights may fog up, which is normal. If a large amount of water droplets or water accumulation appears in the headlights, please contact the Xpeng Service Center.

Automatic mode *

Auto mode is selected and the vehicle automatically adjusts the light height according to the load.



Wiper Operation

Introduction

The combined wiper switch controls the front and rear wipers and washers. Proper use of wipers and washers can improve the driver's visibility in different weather conditions.

Operation

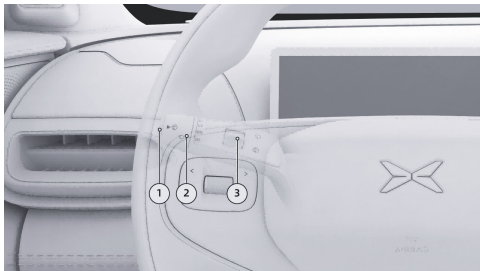

1. Wash switch

- Short press: Brush once.

- Long press: Front washer jet, front wiper.

caution

- The front windshield washing system should not be used for too long each time, otherwise the front washer motor may be damaged.
- When the washer fluid in the storage tank is insufficient, it is strictly forbidden to operate the washer, otherwise the front washer motor may be damaged.

2. Front wiper switch

- OFF: Stop the wiper.
- AUTO: Scratch according to rain.
- LO: Low speed wiper.
- HI: High speed wiper.

3. Rear wiper switch

Move the rear wiper switch down once and the rear wiper brush once.

The rear wiper switch will not be released by swiveling down, the rear wiper will continue



to spray, and the rear wiper will continue to brush, and will come to a stop when hands are released.

Swipe up, rear wiper continuous, then up and stop.

Wiper sensitivity

The “ →window & door” interface can be controlled from the center screen. Set “**Automatic Wiper Sensitivity**”.

Defrost the windscreen in cold weather. In the air conditioning settings interface [See 228 page](#) , Click, “ ”Defrost.

Warnings, Cautions, and Limits

caution

- Before operating the wiper lever, ensure that the front hood and the main driving door are fully locked.
- When washing the vehicle, please turn off the automatic wiper function to avoid damage to the wiper or personal injury.

- When using the wiper in bad weather conditions, make sure that the wiper blade is not frozen/stuck to the windshield.
- If there is snow or debris on the wiper or windshield, remove it before use. Please park the vehicle in a safe area before removing it.

warning

- Automatic wipers are an auxiliary function. The driver still needs to manually adjust the wipers when necessary according to the external environment to ensure driving safety.
- Dry wipers are strictly prohibited. If the rainfall is light, the washer fluid must be sprayed before using the wipers to avoid damaging the windshield and wiper blades.



Shift Operation

Introduction

Shifting is carried out via the gearshift paddles on the right side of the steering wheel.

Operation

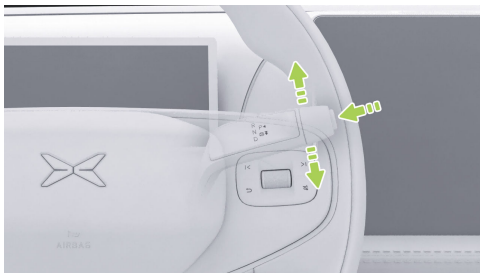

R: Reverse

caution

Please change gears when the vehicle is stationary.

Pressing the brake pedal while pushing the gear selector upwards in second gear will shift the vehicle to R and the reverse lamp will illuminate.

N: Neutral

The vehicle can be switched to N by:

- With the vehicle in D, press the brake pedal and push the gear selector upwards for 1 second.
- With the vehicle in R, press the brake pedal and push the gear selector down to first gear for one second.
- With the vehicle in P, press the brake pedal and push the gear selector up or down for 1 second.

D: Forward gear

Pressing the brake pedal while pushing the gear selector down 2 will shift the vehicle to D.



P: Park

Press the brake pedal while pressing the P switch on the gear selector and the vehicle will now shift to P.

- In the “ → **Window & Door screen**” of the central control screen, “**P Gear Shortcut**” can be opened/closed. When in P, the common controls are displayed in the lower left corner of the central control screen for easy one-touch operation.
- The corresponding gear indicator on the instrument is black after the gear change.
- With vehicle in D or R and vehicle speed less than 3 km/h, without seat belt, brake and accelerator pedals applied, Open the main drive door and the vehicle will automatically switch to P.
- When the conditions are not met, the instrument will alert you with text, follow the instructions and meet the conditions before changing the gear.

Warnings, Cautions, and Limits

Tips

When the vehicle is in D or R gear, and the speed is less than 3 km/h, the seat belt is not fastened, the brake pedal and the accelerator pedal are not pressed, and the main driver's door is opened, the vehicle will automatically switch to P gear.

caution

- Before leaving the vehicle or on a slope, please make sure the vehicle is in P gear to prevent the vehicle from moving without reason.
- If you cannot shift gears normally, you should contact the Xiaopeng Motors Service Center for inspection in time.



Braking Operation

Introduction

The following functions can be set by braking operation:

- Brake pedal feel
- Automatic parking
- Comfort braking
- Electric parking brake

Operation

Brake pedal feel

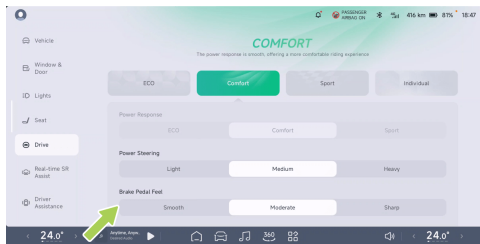

On the “ → Drive screen in” the center control screen, The “**Brake Pedal Feel can be set**”.

The brake pedal feel can be selected to suit your personal preference.

- Smooth: Smooth braking response for a more comfortable ride.
- Moderate: The braking response is moderate, combining driving pleasure with ride comfort.
- Sharp: Responsive braking and confident driving.

Automatic parking

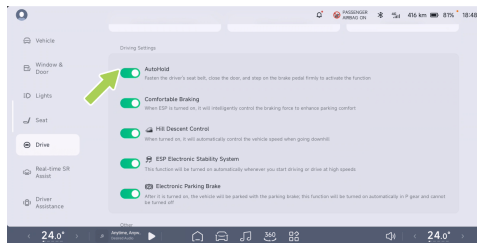



On the “ → **Drive screen in**” the center control screen, “**AutoHold**” can be selected on/off.

- For a short stop, automatic parking can be activated, the brake pedal released and the system will automatically apply the brakes and hold the vehicle stationary.
- Function activation: Deep brake pedal application when vehicle is stationary, instrument illuminated, automatic parking active, brake pedal can be released.

Tips

Automatic parking can only be activated when the main driver's door is closed, the seat belt is fastened, and the gear is in D/R/N gear.

- Function exit: When automatic park is active, the accelerator pedal is pressed to automatically park out.

Tips

- When the automatic parking is activated, opening the main driving door or unbuckling the seat belt will automatically switch to EPB.
- After the automatic parking is maintained for a period of time, it will switch to EPB.

caution

Automatic parking cannot exceed the laws of kinematics. Please enable automatic parking according to the road conditions.



Comfort braking

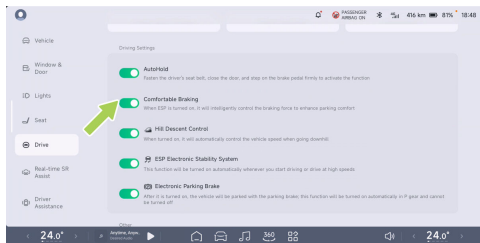

In the center control screen “ → **Drive**” interface, “**Comfortable Braking**” on/off selectable.

- When switched on, the system intelligently controls the braking force at the end of the brake, automatically and smoothly releasing the brake pressure, improving the vehicle's braking comfort. It effectively suppresses the nod of the brakes.

Electric parking brake

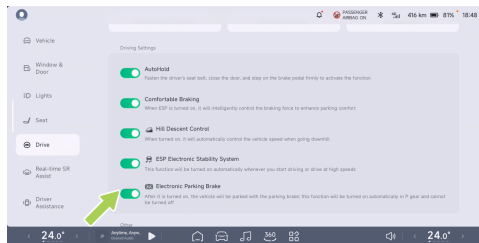

In the center control screen “ → **Drive**” interface, “**Electronic Parking Brake**”(EPB) can be selected on/off.

- When the vehicle is stationary, Turn on the “**Electronic Parking Brake**” or press the P switch, Instrument illuminated, EPB switched on successfully.
- With the vehicle stationary, press the brake pedal to shift to non-P, Turn off the “**Electronic Parking Brake**”, Meter off, EPB off successfully.



i Tips

- When the vehicle is in P gear, EPB cannot be turned off by turning off the "electronic parking brake".
- When opening/closing EPB, the system will make operating noise, which is normal.
- In special cases, long pressing the P gear switch can turn on the EPB emergency brake function.

⚠ caution

- If the vehicle cannot open/close the EPB normally, contact the Xpeng Motors Service Center immediately for inspection.
- If the vehicle cannot be powered on due to battery depletion and the EPB cannot be turned off, you can turn it off by jump starting or contact the Xpeng Motors Service Center for processing.
- Do not drive the vehicle without turning off the EPB, otherwise it is very easy to damage the EPB.

Driving mode

Operation

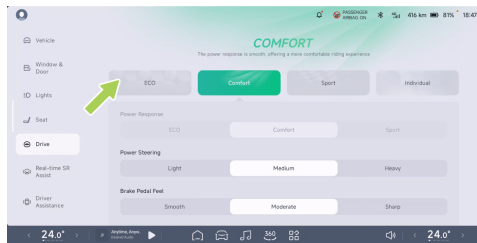

On the “ → **Drive screen**” in the center control screen, The driving mode can be selected according to your personal preference.

- **ECO**: The power response is slow, extending the vehicle range
- **COMFORT**: The power response is smooth, offering a more comfortable riding experience
- **SPORT**: The power response is swift, offering great driving pleasure.



- **INDIVIDUAL**: The user can adjust multiple parameters for personalized driving pleasure.
- **All-Terrain***: The power response is smooth, offering the maximum torque to improve all-terrain capacity

Only “” in SPORT mode, The “**Launch**” switch is displayed.

Ejection mode is only active during this up and down cycle, and will exit Ejection mode if Ejection is switched off or the vehicle is powered back on.

Regeneration

Introduction

Energy recovery converts some of the vehicle's kinetic energy into electrical energy when the vehicle coasts or brakes, charging the power battery for increased battery life.

Operation

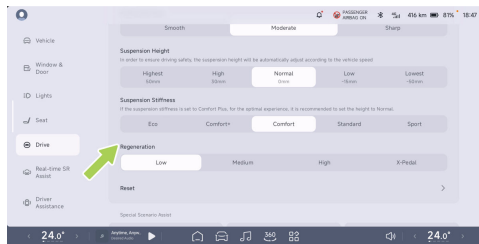

On the “ → **Drive**” screen in the center control screen, “**Regeneration**” can be set.

Factors that affect energy recovery

The amount of power supplied to the power battery by means of energy recovery depends on the following factors:

1. The current status of the power battery.
 - Power battery level.
 - Power battery temperature.



2. The selected energy recovery level.

Warnings, Cautions, and Limits

i Tips

- Different levels of regenerative braking correspond to different driving experiences.
- If regenerative braking significantly reduces the vehicle's speed (for example, when driving on a steep slope), the brake lights will illuminate to alert the driver of the vehicle behind you that you are slowing down.
- When the battery is at 100% charge, regenerative braking is not possible; when the battery is at a high charge, regenerative braking is reduced.

⚠ warning

The braking effect generated by energy recovery cannot meet the braking required to ensure safe driving. The driver should apply

brakes to the vehicle in a timely manner according to the actual situation.

4WD system *

Introduction

The vehicle's drive system is four-wheel drive and requires no human intervention. The system intelligently switches between two-drive and four-drive modes depending on the vehicle operating conditions.

When the vehicle is on a better road, in order to ensure the vehicle's driving comfort and economy, the vehicle will take priority to use two-drive mode. Switch to 4WD mode when the driver has a high demand for power, and when the vehicle is on slippery, muddy, ice, driving on sandy surfaces, on complex surfaces in the wild, at medium to high speed acceleration, at large dynamic cornering, etc. The timely intervention of the All-Wheel Drive system ensures four-wheel traction with intelligent torque distribution for



optimum pass and safety. Ensure vehicle stability and comfort.

Power Steering

Operation

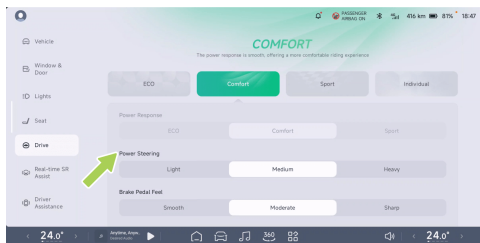

On the center control screen “ → Drive” interface , in “Power Steering” “Light, Medium, Heavy” can be selected.

- Light: Minimal steering effort, recommended for comfortable driving.

- Medium: Moderate steering effort, generally recommended for driving.
- Heavy: Steering is heavy, recommended for sports driving.

warning

- It is prohibited to adjust the steering wheel position while driving the vehicle.
- Improper adjustment of the steering wheel position may cause personal injury. The distance between the steering wheel and the driver's chest must be at least 25 cm.

Use a anti-slip chain

Introduction

When the vehicle is being driven in harsh environments such as snow or icy roads in winter, the use of anti-slip chains increases tire friction and reduces side slippage. When using a non-slip chain, the following must be observed:



- It is necessary to install tire chains on the tires when driving the vehicle in deep snow. This vehicle is not fitted with a non-slip chain and can be purchased on request. If a chain is fitted, an equivalent of the size and type of the vehicle's tire size must be selected.

The rims and tire sizes for this vehicle are as follows:

Rim size	Tire size
20" rims	255/50 R20
21 inch rim	255/45 R21

- Install the chains on the tires to ensure a balanced ride in all weather conditions. It is important to remember that the vehicle may not have sufficient power when the anti-slip chain is fitted. Drive with care even when the road is in good condition. Do not drive above the specified speed limits for the tire chains or 50 km/h, whichever is lower.

- Use snow chains on the rear wheels only. Install snow chains in pairs. Never use self-tensioning snow chains.
- Do not use the chains on dry ground and remove the chains after driving on a snow-free surface.
- Once the tire chains are fitted as tightly as possible to the tires, after 0.5 to 1.0 km, tighten the chains again.
- If the vehicle is fitted with a wheel cover, remove it before installing the snow chains.
- Stop and retighten the snow chains if you hear a chafing or collision with the vehicle while driving. If this does not work, remove the snow chains to prevent damage to the vehicle.

Intelligent High Beam IHB

Introduction

The IHB automatically switches high and low beam based on the vehicle ahead, ambient light,



etc. Avoid interference with surrounding traffic participants.

Instrument indicator lights



The IHB is switched on and the high beam lamps are not illuminated.



The IHB is on and the high beam lights are on.



The IHB is faulty.

Operation

Turn on and off

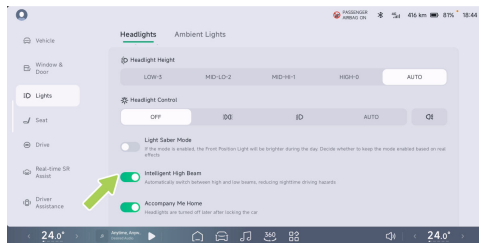

In the central control screen “ → **Lights** → **Headlights**” interface, “**Intelligent High Beam**” can be switched on/off.

Use IHB

The IHB is active and the vehicle automatically switches high and low beam depending on the road environment when the following conditions are met:



1. The central screen light switch is in the automatic position.
2. The vehicle speed is greater than 30 km/h.

i Tips

When IHB is activated, if the vehicle speed is less than 15 km/h, IHB will be deactivated.

Steering Wheel Position Adjustment

Introduction

Before driving the vehicle, adjust the steering wheel height and the distance from the steering wheel to the body, so that the steering wheel is held comfortably in a suitable driving position.

Operation



Say “Hey Xpeng, Steering wheel adjustment” or in the center screen “ → Drive” interface, “After opening the Steering Wheel Controls, The steering wheel height can be adjusted fore and aft to the correct position via the steering wheel left and right wheels.

i Tips

Swipe down from the top of the central control screen and you can turn on the steering wheel adjustment function in the quick panel.



caution

- Roll the left and right wheels at the same time, and the system will give priority to the direction that issues the fastest instruction, and then perform the adjustment in the other direction.
- It is forbidden to use the wheel to adjust the steering wheel position for a long time. Long-term continuous operation will cause the electric adjustment device to enter the overheat protection state, and it will take some time to use it again.
- The adjustment sound emitted during adjustment is a normal sound. If there is any abnormality, please contact the Xpeng Service Center.

Warnings, Cautions, and Limits

warning

- After adjusting the steering wheel position, please confirm whether the steering wheel

is locked, otherwise it may cause personal injury and property damage.

- Do not adjust the steering wheel while driving.

Automatic Anti-glare Interior Rearview Mirror

Introduction



1. Front light sensor
2. Rear light sensor

Driving Operation



The light sensor detects the level of light coming from behind and in front of the vehicle. Based on the measured data, the interior mirror automatically adjusts the anti-glare status.

caution

Do not block or cover the light sensor on the rearview mirror, and clean the dirt on the surface of the light sensor in time.

Operation

Adjust mirror angle

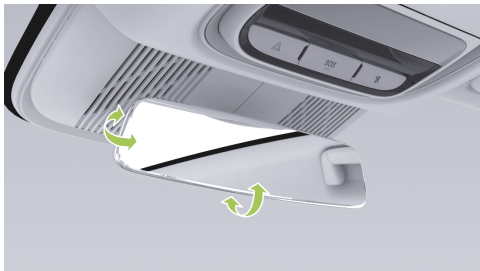

1. Adjust the driver's seat to the appropriate position.
2. While holding the interior mirror up and down, adjust the angle of the interior mirror left and right to adjust the position where you can see the rear of the vehicle through the interior mirror.

Tips

When adjusting the rearview mirror angle, it is recommended to use both hands.



Air Conditioning

The page displays





1. PM2.5
 - Click on the card to switch air purification on/off.
 - Displays the interior air quality.
2. Passenger air conditioning unit
 - Displays the temperature and air volume status of the current passenger air conditioning.
 - Adjust the passenger air conditioning.
3. Adjust the steering temperature
4. Extreme speed climate control/intelligent air conditioning
 - Extreme cooling: When switched on, the air conditioning temperature is reduced to a minimum, air volume is adjusted to a high gear and seat ventilation is automatically switched on.
 - Extreme Boost: When switched on, the air conditioning temperature is maximized, air volume is correlated to high, and seat

heating and steering wheel heating are automatically switched on.

Tips

To enhance the comfort experience, it is recommended to remotely turn on the air conditioner through the mobile phone app for rapid cooling/heating in summer (high temperature) or winter (low temperature).

- ... Smart mode.
5. Heated defrost/internal/internal circulation
 - Switch on/off the front windshield defrosting.
 - Switch on/off the rear window glass heating defrost and the exterior mirrors heating defrost.

Tips

During the heating process, if the 12V battery voltage is lower than 9V, the



system will automatically turn off the heating function.

caution

- When the vehicle is not started, it is forbidden to use the heating and defrosting function for a long time to avoid the 12V battery running out of power and being unable to start the vehicle.
- When the heating and defrosting function is turned on, do not touch it with your hands.

-  Toggles the internal and external loop.



6. Switch air conditioning on/off

Tips

It is recommended not to turn on the air conditioning system during charging.

7. Adjust air volume

8. Blow mode

-  Blowing windows.
-  Blow surface.
-  Blow your feet.

Tips

- Red wind means the set temperature is higher than the temperature inside the car and the air conditioner is heating.
- Blue wind means the set temperature is lower than the temperature inside the car and the air conditioner is cooling.
- Gray wind means the set temperature is close to the temperature inside the car and the air conditioner is maintaining the temperature.

9. Air conditioning mode

- Tap “**Simultaneous**” On/Off host drive temperature to adjust in parallel with passenger temperature.



i Tips

When you select Energy Saving mode, Temperature Sync is automatically turned on.

- A/C: The air conditioning is cooled or heated after switching on.
- AUTO: The air conditioning is automatically controlled when switched on according to a set temperature.

10. Adjust the host drive temperature

11. Main drive air conditioning components

- Displays the current host air conditioning temperature and air volume status.
- Adjust the host drive air conditioning.

i Tips

The air conditioning can also be controlled via the steering wheel and voice.

Air conditioning mode

In the lower right corner of the climate settings screen, Tap “ … ” Different climate intelligence modes can be selected depending on the situation.

Refresh

Ideal for removing the smell of a new vehicle quickly at the beginning of the vehicle collection, or when an unusual smell is found in the vehicle while driving. When activated, ventilation is maintained for 180 seconds to improve driving comfort.

Energy-saving mode

When the energy saving mode is on, the air conditioning will operate in a more energy efficient mode, reducing the air conditioning power consumption and extending the range. The cooling or heating effect of the air conditioning will be affected when switched on.



Exhaust protection

When switched on, when the vehicle detects exhaust pollution outside the vehicle, it automatically switches to recirculation mode to ensure the air quality inside the vehicle.

Intelligent Passenger SideVent

When you drive alone, it is recommended to switch on “**Intelligent Control Ventilation**”. When this feature is switched on, the passenger vents are closed when the passenger is not present, reducing air conditioning power consumption. Extend your range.

Intelligent cleaning

When switched on, if the air conditioning is still operating when you exit the vehicle lock, it will intelligently detect the water in the air conditioning system and turn on the smart clean function. Reduces bacterial growth and the chance of creating odors in the vehicle interior. The Smart Clean feature consumes a certain amount of power and has a small impact on battery life.

Air purification

The air purge function takes the interior air quality from sensors and the network, displays it on the air conditioning screen and proactively alerts you to turn on the air purge function when the interior air quality is poor.

Air purification can be turned on by:

- To little P: Air purification.



- Click on the area below the central control screen PM2.5 to start the purification.

Comfort Equipment



- When AUTO is switched on, purging is automatically switched on when the interior air quality level is moderately polluted and above.

Air purification can be withdrawn in any of the following ways:

- Automatic stop for continuous 30s when the interior air quality level is good and below.
- In purge, tapping the air purge icon in the upper right corner of the climate control screen again will stop purging.
- In air purification, turn off air conditioning, switch on front defrost and exit purification.
- In air purification, turn on extreme heat, cool down very quickly, intelligent smell removal, Exit purge.

Air outlet adjustment

The front air vents can be adjusted manually via the central climate settings screen and small P voice, and the rear air vents can be adjusted manually.

Adjust the front exhaust vent

On the air conditioning setting interface [See 233 page](#) the air vents can be opened/closed, the wind direction can be adjusted manually, and the air mode can be selected by clicking on the blank area of the screen.



1. Drag the wind effect up, down, left, and right to adjust the wind direction manually.
2. Tap the air vents to open/close the corresponding air vents.



i Tips

When the air outlet is closed, the air outlet effect changes into a dynamic ring.

3. Ventilation mode

- Free Vent: Drag the airflow effect to adjust the direction of the individual vents.
- Driver's /Passenger's Indirect Vent: The wind direction of the vents avoids the core thoracic position of the master/passenger.
- Intelligent Vent: Intelligently adjusts the wind direction of the vents based on the interior/exterior temperature and usage scenario.
- Sweep: Drag the wind effect to adjust the sweep height.

i Tips

- After adjusting the wind direction of a single air outlet in the avoidance main/co-pilot and smart wind modes, it will switch to free wind mode.

- After turning on the left and right wind sweeping mode, the main/co-pilot air outlets will be synchronized to the left and right wind sweeping mode.

Drain air vent after adjusting



Move up and down to adjust the direction of the vents, turn left and right to adjust the airflow, and turn left/right fully to close the vents.



Steering Wheel

Steering wheel keys

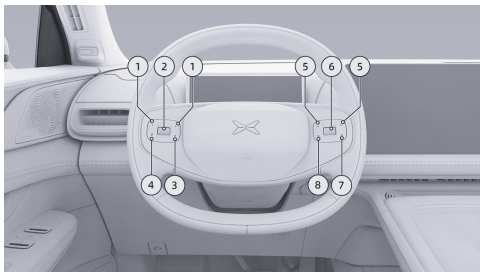

1. Left and right keys:

- Default: Adjust air conditioning volume.
- With ACC/LCC on, adjust the cruise gap.
- Controls the left-hand exterior mirror mirror mirror lens pan left and right when the exterior mirror adjustment is woken up.

2. Upper and lower wheels:

- Scroll up and down to adjust the air conditioning temperature.
- Press and hold to enter the left-hand screen switch card mode of the instrument, scroll up or down to select a card, and briefly press to confirm selection.
- Scroll up and down when ACC/LCC is on to increase or decrease the vehicle speed.
- When the exterior mirror adjustment is awake, the scroll up and down controls the left side exterior mirror lens up and down.

3. Steering wheel shortcuts:

Long press to set the key function, short press to perform the set function.

4. Wake on Voice key:

Wake up or turn off small P-voice.

5. Top/Next Curved Keys:

- Short press to play the previous or next station/chapter/song.
- Controls the right-hand exterior mirror mirror mirror lens pan left and right



when the exterior mirror adjustment is woken up.

6. Upper and lower wheels:

- Scroll up or down to adjust the media volume.
- Briefly press Multimedia Play/Pause/Pop-up to confirm.
- Press and hold to enter the right-hand side of the instrument cluster card selection.
- When an incoming call is in progress, scroll up/down to answer/reject, and briefly press the scroll wheel to confirm. While answering a call, briefly press Hang Up.
- When the exterior mirror adjustment is awake, the right-hand exterior mirror lens is tilted up and down by the scroll control.

7. Mute key: Short press Mute/Unmute.

8. Back key.

Horn



Press the horn identification area and the horn will sound.

caution

Do not press the speaker mark area for a long time, otherwise the speaker may be damaged.

Key emergency function

Press and hold both the Voice Wake-up key and the Mute key at the same time to restart the instrument and the central control screen.



This function can be temporarily used in the instrument or central control screen display abnormal, suddenly stuck screen, such as after reboot the fault still not repaired, please contact Xpeng car service center in time for repair.

Steering wheel shortcuts

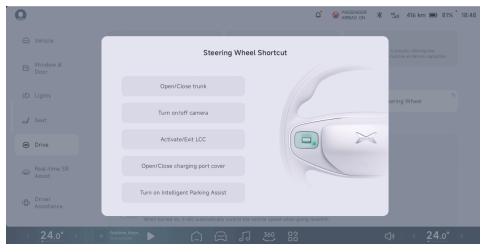

Press and hold the steering wheel shortcut or in the center screen “**Drive**→**Steering Wheel Shortcut**”interface, The steering wheel shortcut functions can be set.

Steering wheel heating

Steering wheel heating can be controlled by:

- Mobile App Key
- Small P-voice
- Central control screen
 - Bottom taskbar (if set up)
 - Setup screen

CID setup screen

In air conditioning setting interface [See 233 page](#) , Click “**Seats and Steering Wheel**”to enter the setup screen.

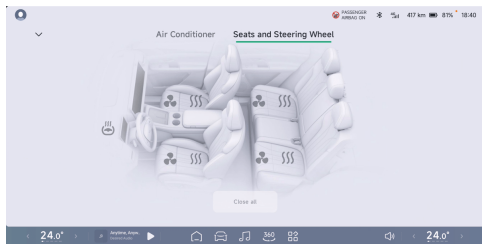

Tap “” Turn on the steering wheel heating, In 3rd gear, repeat taps for 2nd gear, 1st gear, OFF, 3rd gear cycle.

Windows

Introduction

Windows can be opened/closed by:

- Window switches
 - Main drive side window switch
 - Passenger's window switch
- Mobile App Key

- Small P-voice
- CID setup screen

Tips

- Do not open and close the window repeatedly in a short period of time, as this will trigger the thermal protection of the window. After the thermal protection, the window lifting function will fail and you need to wait for about 2 minutes before operating again.
- When the window is closed with one button, if it is blocked by an obstacle in the anti-pinch area, the window will stop closing and retreat a distance.
- If the window is closed with one button and the anti-pinch function fails, you can perform the window initialization operation.

warning

- When there are children in the car, in order to ensure safety, the passenger window lift



should be locked to prevent children from operating the window to avoid pinching.

- Even if the window is equipped with an anti-pinch function, there is still a possibility of pinching when closing the window. It is forbidden to start the anti-pinch by blocking the window with any part of the body.
- Before closing the window, the driver must ensure that all passengers (especially children) do not stick any part of their body out of the window, otherwise there is a risk of pinching!
- After the automatic window closing function is turned on, the window will automatically close when the car is locked. Please make sure that the window will not get stuck on passengers or obstacles and there are no passengers (especially children) in the car before locking.
-

Operation

Main drive side window switch

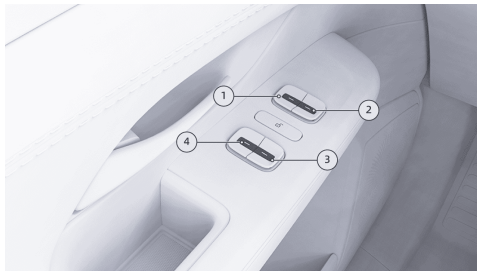

1. Left front door glass raise/lower switch
2. Right front door glass raise/lower switch
3. Rear right door glass raise/lower switch
4. Rear left door glass raise/lower switch



Passenger's window switch

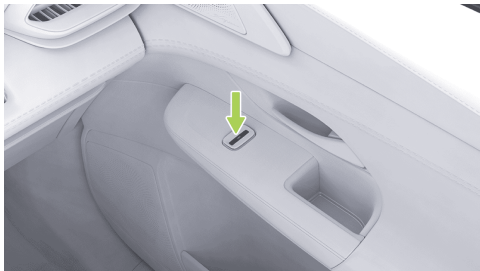

Short press switch front/rear: One touch up/down, windows automatically operate to the fully closed/open position.

Press and hold the switch front/rear: The window starts to raise/lower, release and stop.

CID setup screen

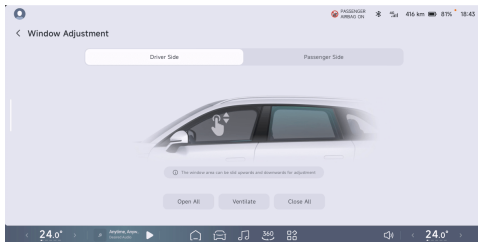

In the center screen, “**Window & Door**→**Window Adjustment**”interface, Window “**Open All , Ventilate, Close All**”can be set. It can also be adjusted by sliding up and down in the window area.

i Tips

When the window locks are on, the window switches on other doors are disabled and all windows can only be adjusted via the driver's side window switch.



Window locks

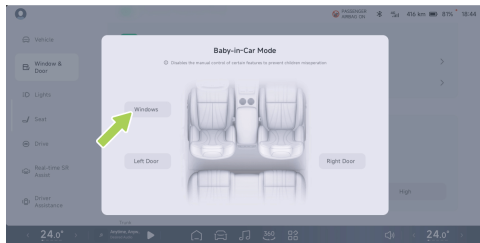

In the center control screen “ → **Window & Door** → **Baby-in-Car Mode**” interface, Window locks can be switched on/off.

Close the window automatically

In the center control screen “ → **Window & Door**” interface, “**Close Windows Automatically after Vehicle Locking** can be turned on/off” and “**Close Windows Automatically when Traveling at High Speeds**” feature.

Tips

After turning on the automatic window closing when driving at high speed, it is recommended to turn on the external circulation mode when driving at high speed.

Window initialization

Window initialization can be performed when operating a window if there is an anomaly (e.g. one-touch lift failure, central screen and voice cannot be adjusted):

1. The vehicle is powered up and the doors are closed. Press and hold the front of the window glass lift switch to raise the window to the global closed position for 2 seconds, then release your hands.
2. Press and hold the rear of the window glass lift switch to lower the window to the global open position for 2 seconds, then release to complete the window initialization.

The following checks to see if the initialization is complete:



Comfort Equipment

1. Briefly press and release the rear of the window glass lift switch to automatically lower the window to the global open position.
2. Briefly press and release the front of the window glass lift switch to automatically raise the window to the closed position.

caution

- The process of setting the windows fully open and fully closed must be completed within 15 seconds.
- Setting the windows fully open and fully closed must be completed continuously. If only one of the steps is completed, the anti-pinch function may fail. Both steps must be completed continuously to avoid this risk.

warning

- Before closing the windows, the driver must ensure that all passengers (especially children) do not stick any part of their body out of the window, otherwise there is a risk of injury!

- When locking the car, the windows will close automatically. The driver must lock the windows only after ensuring that the windows will not trap the passengers.
- Before leaving the vehicle, please make sure that the vehicle is powered off.

Sun Visor and Vanity Mirror

Introduction

Sun visor



Comfort Equipment



Roll down the sun visor in the direction of the arrow to block the sunlight coming from the front window.



Once the sun visor has been tilted down, remove the end of the sun visor from the bracket near the inner mirror and flip the sun visor toward the window to block the sunlight coming from the window glass.

warning

The folded-down sun visor may affect your forward vision. If you no longer need to use the sun visor, be sure to retract it into the bracket.

Vanity mirror



Vanity mirrors are available in the main vehicle sun visors and can be used for finishing your faces.

- Deploy the sun visor to a suitable position, flip down the vanity mirror cover (which can also



be magnetized to the back of the visor) to illuminate the vanity mirror lamp.

- When the vanity mirror cover is closed, the vanity mirror lamps are switched off and the sun visor is folded.

i Tips

- When the vanity mirror is not in use, please close the vanity mirror cover.
- If the vanity mirror cover is magnetically attached to the back of the sun visor, when the vanity mirror is not in use, please adjust the sun visor to the non-use position to turn off the vanity mirror light.

⚠ warning

Do not use the vanity mirror while driving your vehicle.

Panoramic Skylight

Introduction

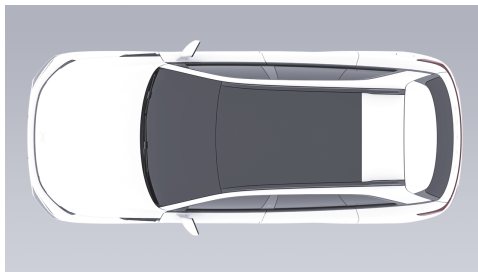

The vehicle is equipped with a panoramic roof that gives you greater visibility and a heat-resistant coating to enhance your experience.

⚠ caution

After the vehicle has been exposed to the sun, the temperature of the panoramic skylight rises. Please do not touch it at this time, otherwise there is a risk of burns.



Interior lighting

Reading light

The reading lamps can be switched on/off in the following ways:

- Reading light switch
- Central control screen
 - Setup screen
- Small P-voice

i Tips

When you open the door, the reading light automatically turns on; when you close the door, the reading light automatically turns off.

⚠ warning

When the ambient light is weak, please do not turn on the front reading lights while driving, as reflections may appear on the windshield, causing you to have difficulty seeing the road ahead and causing a safety accident.

Reading light switch

Front reading lamps



The reading lamp is installed in the roof header lamp assembly, the touch lamp cover reading lamp illuminates and the touch reading lamp extinguishes again.

Rear reading lamps



Press the reading light switch on the opposite side, the reading light comes on and press the reading light again to turn off.

CID setup screen

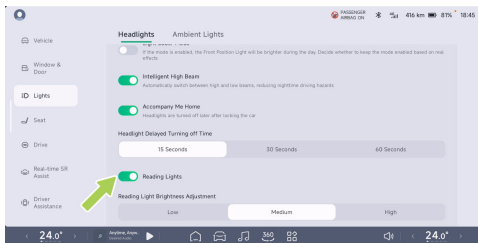

In the central control screen “ → **Lights** → **Headlights**” interface, “**Reading Lights can be switched on/off**”, When the reading lamp is illuminated, the reading lamp brightness can be adjusted.

Ambience lighting

The vehicle is equipped with ambient lighting that changes color as the tone changes, adding to the warmth of the night before you return home.



Turn on and off

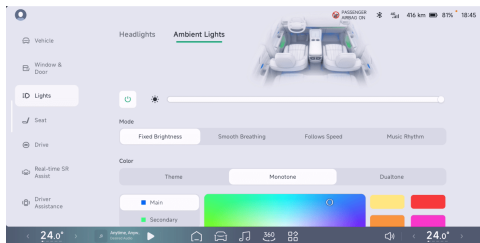

In the center control screen “ → **Lights** → **Ambient Lights**” interface to set ambient lighting.

Brightness adjustment and color selection

When the ambient lighting is on, the ambient lighting brightness can be manually adjusted. Theme, Monotone, Dualtone options are available depending on the mode.

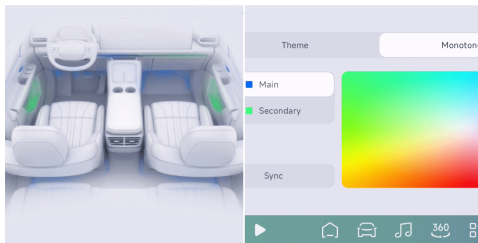

“**Monotone**” option, “**Main**” and “**Secondary** can be selected separately”, A “**”** color can also be selected for Sync All.

Ambience lighting mode

Ambience lighting has four mode settings: Fixed Brightness, Smooth Breathing, Follow Speed, Music Rhythm, Selection is available on the ambience lighting control screen.

Glove box lighting

The glovebox lamp illuminates when the glovebox is switched on and automatically extinguishes when the glovebox is switched off.



Trunk lighting



The trunk lamp illuminates automatically when the trunk is opened.

Raise and lower the loudspeaker luminance *

The bottom light of the speaker illuminates while it is raising or lowering.

Seat Heating *

Introduction

Seat heating can be controlled by:

- Rear Seat Heat Switch *
- Mobile App Key
- Small P-voice
- Central control screen
 - Bottom taskbar (if set up)

i Tips

The bottom task bar only supports controlling the driver/passenger seat heating.

- Setup screen



Operation

Rear seat heating switch



Press the rear seat heat switch to turn on the seat heat function, the gear is in third gear, press repeatedly in second gear, first gear, off, and third cycle, the switch indicator light will accompany the gear display.

CID setup screen

On air conditioning setting interface See 233 page , Tap “**Seats and Steering**” to enter the settings screen.

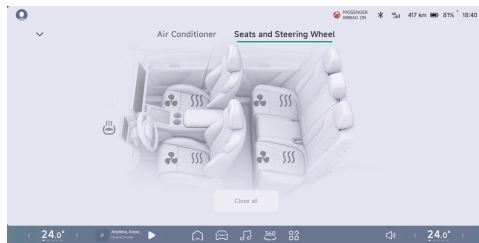

Tap “” To switch on the heating for the corresponding seat, In 3rd gear, repeat taps for 2nd gear, 1st gear, OFF, 3rd gear cycle.

warning

- If the driver or passenger cannot feel pain in the part of the body that contacts the seat, please do not use the seat heating function, otherwise it may cause personal injury.



- Long-term use of high-speed heated seats can easily cause low-temperature burns.
- Long-term use of the main driver's seat heating may induce drowsiness and affect driving safety.

caution

If a child safety seat is installed in the rear seat, do not turn on the seat heating function.

Seat Ventilation *

Introduction

Seat ventilation can be controlled by:

- Rear seat vent switch *
- Mobile App Key
- Small P-voice
- Central control screen
 - Bottom taskbar (if set up)

Tips

Only supports driver/passenger seats.

- Setup screen

Operation

Rear seat vent switch



Press the rear seat ventilation switch to switch on the seat ventilation function, the gear is in 3rd gear, press repeatedly in 2nd gear, then in 1st gear, Off, 3rd gear cycle, switch indicator light accompanied by gear display.

Comfort Equipment



CID setup screen

On air conditioning setting interface See 233 page , Tap “**Seats and Steering**”to enter the settings screen

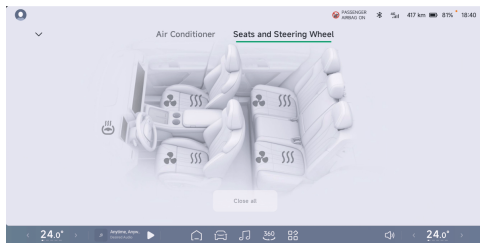

Tap “”To switch on the ventilation for the corresponding seat, In 3rd gear, repeat taps for 2nd gear, 1st gear, OFF, 3rd gear cycle.

Seat Massage *

Introduction

Seat massage can be controlled by:

- Front seat massage switch *
- Rear seat massage switch *
- Small P-voice
- Central control screen

Operation

Front seat massage switch

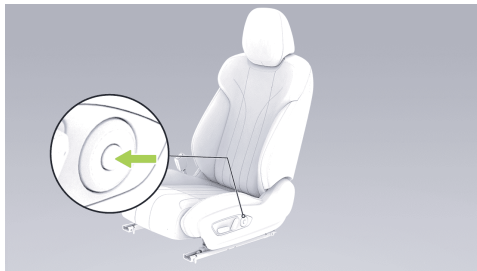

Click the circle center key to toggle the massage on or off.



Rear seat massage switch

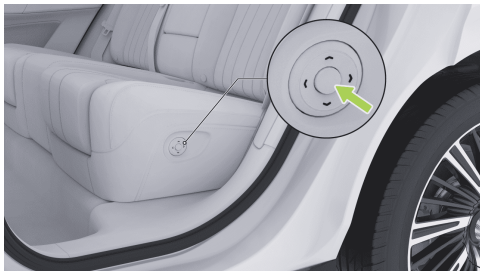

- Click the circle center key to toggle the massage on or off.
- Up and down keys: Massage mode switch.

CID setup screen

On the “ → **seat** → **massage**”, Set the seat massage settings.

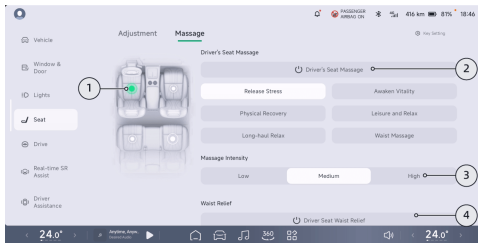

1. Tap “” Select the seat that requires adjustment.
2. The massage mode can be selected to suit your personal preference and the seat massage can be switched on by clicking on it.

Tips

Different massage modes correspond to different massage durations. When the time is reached, the seat massage will be automatically turned off.

3. Tap to select the massage intensity.
4. Tap to select lumbar retarding mode.



i Tips

- The main driver's massage and lumbar pressure relief can only be turned on separately. When the massage is started, turning on the lumbar pressure relief will automatically turn off the massage; when the lumbar pressure relief is started, turning on the massage will automatically turn off the lumbar pressure relief.
- When the lumbar pressure relief mode is started, manually adjusting the lumbar support will interrupt the lumbar pressure relief mode.

Host drive sound *

Operation

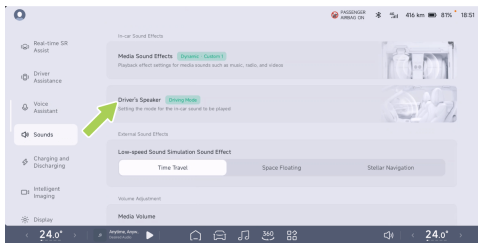

In the center control screen “ → **Sounds** → **Driver's Speaker**” interface, The host drive audio mode can be set.

There are three modes for the host drive audio:

- Shared Mode: Navigation, call and media sounds are played through the full car audio.
- Driving Mode: Navigation and call sounds are played through the host head restraint and



media sounds are played through the full car audio.

- Private Mode: Navigation, call and media sound is played via the host head restraint.

“When the Intelligent Switch is turned on, When there is a co-chair, Automatically switches to **“Driving Mode”**”.

Wireless Charging

Introduction

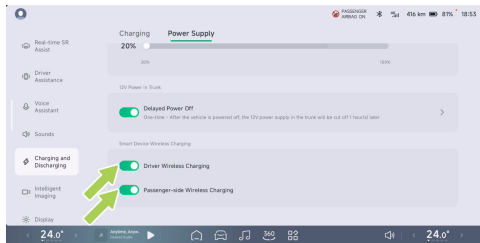

In the center control panel “**Charging and Discharging**→**Power Supply**”interface, Wireless primary/secondary charging can be switched on/off.

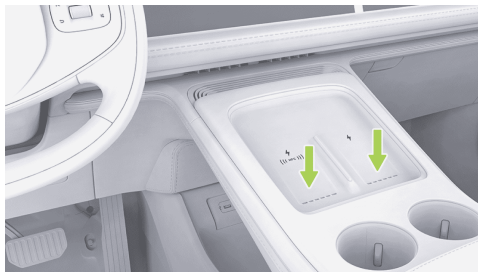

! caution

Some mobile phones do not have wireless charging function. Placing the phone on the wireless charging panel may cause the screen to flicker or jump. If necessary, it is recommended to turn off the wireless charging switch on the central control screen.



The wireless charging area is located at the front of the sub-meter, and when charging, slide the phone up and down the stop bar to the bottom of the charging area to help the phone sense charging and to help cool the phone. The icon is displayed on the central control screen while charging “” in the next step.

- Wireless charging power for mobile phones is up to 50W and air-cooled. Reduce the temperature of your phone with air cooling and increase your charging efficiency.
- In the center control screen “” → **General** → **Safety and Privacy**” interface, “**Cell Phone Left Behind Reminder**” can be turned on/off, When the mobile phone is charged wirelessly when switched on, leaving the vehicle will trigger a legacy alert.

Wireless charging will stop when:

- When the phone is placed at the top of the charging area, it may break or not sense.
- Stop charging when the vehicle search key is activated.

- The left front door is unlocked, four doors are closed, when the trunk is closed.

warning

- To avoid interference between medical or implantable electronic devices and mobile phone wireless charging systems, people using medical or implantable electronic devices should keep an appropriate distance from the mobile phone wireless charging area.
- The mobile phone wireless charging function heats metals. Please make sure that there are no metal foreign objects on the back of the mobile phone and in the charging area before starting charging, otherwise the metal foreign objects may be heated or damaged, or even cause safety accidents. Metal foreign objects here refer to other objects with metal components, including but not limited to chips, magnetic cards, etc.



- For mobile phones without wireless charging function placed in the charging area, it is recommended to manually click on the central control screen settings to turn off the wireless charging function in the corresponding area to avoid affecting the normal use of the mobile phone.
 - For mobile phones with 50W wireless fast charging, the mobile phone must be placed at the bottom of the charging area along the limit strip, and the bottom of the mobile phone must completely cover the air outlet to avoid overheating.
 - The air outlet of the wireless charging cooling fan is located at the lower end of the wireless charger. Please pay attention to foreign objects and liquids entering the air outlet to affect the fan operation.
 - Do not sprinkle water in the wireless charging area to prevent water from entering the wireless charging module and damaging electronic components.
- External wireless charging coils may cause accidents, please use with caution.
 - When the driver is not in the car, please do not place the phone in the car to charge to avoid safety hazards.
 - Please do not place heavy objects in the charging area to avoid damaging the wireless charging module.
 - If the wireless charging function fails or cannot be used normally, please stop using it and contact the Xpeng Motors Service Center for inspection.
 - It is normal for the phone to heat up after charging for a long time. Do not continue to place the charging device in the charging area after it is fully charged to avoid overheating.
 - Do not use a mobile phone case with metal material, such as a mobile phone case that supports magnetic charging (MagSafe).



Power and Data Interface

Introduction

Interface on the interior rearview mirror base

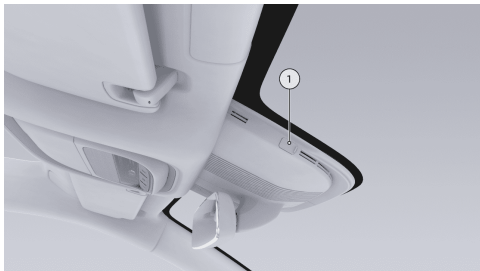

1. USB power interface: can power the driving recorder, with a maximum output current of 2.1A.

caution

- To avoid damaging the vehicle's electrical system, do not connect power generation equipment to the USB power interface.

- When the vehicle is powered on or off, the charging device connected to the USB power interface should be disconnected to avoid damage to the electrical equipment due to voltage fluctuations.
- When no one is in the vehicle, the USB power interface is prohibited.
- Improper use of the USB power interface can easily cause a fire.
- It is prohibited to use high-power electrical equipment.
- Children are prohibited from operating it.



Central console box front interface

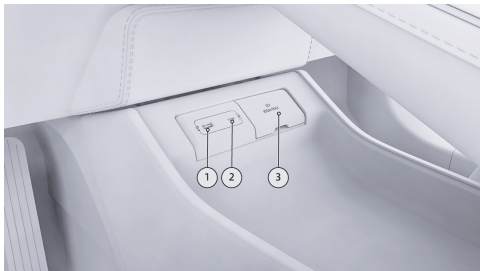

1. USB media source interface: used for driving video USB flash drive data transmission, microphone, game controller, etc.
2. Type-C power interface: used for driving video USB flash drive data transmission and electronic device charging, supports standard charging protocol, maximum power is 60W.
3. 12V power interface: maximum supported power is 180W.

caution

Do not use the USB media source interface for charging. Charging may cause the central control screen to restart or go black.

Central armrest rear interface



1. USB power port: Connect a USB cable for charging.
2. Type-C power port: Maximum supported power is 60W.

Comfort Equipment



warning

It is prohibited to modify the Type-C interface without permission.

Trunk internal interface



12V power interface: maximum supported power is 180W.

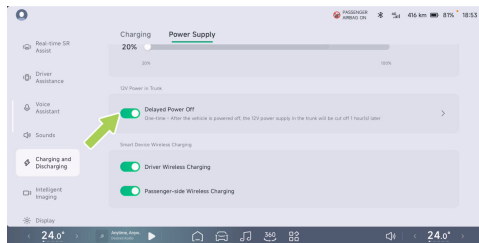

In the central control screen “ → **Charging and Discharging** → **Power Supply**” Interface, open “**Delayed Power Off**” can set the delay time for the trunk 12V power to be cut off after the vehicle is powered off.



Loadspace Sunshade

Use the Sunshade

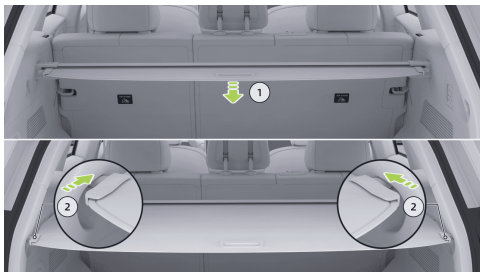

1. Pull out the sunshade.
2. Snap the ends of the blind into the retaining slots on both sides of the loadspace.

warning

After the sunshade is unfolded, it is prohibited to place any objects on it, otherwise the sunshade may be damaged or the objects may

be thrown forward and cause injury to the occupants in the car in the event of a collision.

Remove and install the sunshade

- Fold the rear seat backrest.
- Retract either end of the blind and remove the blind.
- When installing, snap one end of the blind into the retaining slot first, retract the other end of the blind and snap it into the retaining slot.



Storage Space

Introduction

Front compartment storage box



There is a storage compartment in the front compartment for stocking items that are smelly or infrequently used.

Glasses box



The eyeglass box is integrated with the front interior lighting for positioning the eyeglasses.

Press on the case and the case will open slowly, push the case back up to close it.



Central armrest



There is a central armrest compartment on the sub-meter, which can be opened and used by pressing the switch.

Door storage compartment

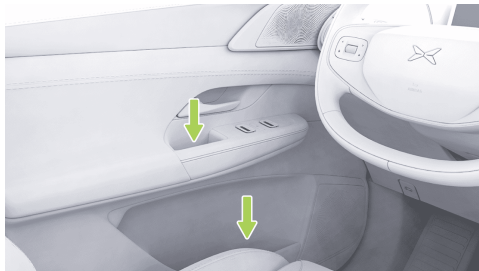

The doors are equipped with a storage compartment for drinks or storage.

caution

Do not place glasses, lighters or spray cans in storage devices to avoid damage to the items due to bumps.

Comfort Equipment



Glove box



Press the glovebox unlock switch to open the glovebox and push it back to lock when not in use.

caution

When not in use, make sure the glove box is closed. Otherwise, in the event of an accident or emergency braking, the contents of the glove box may fly out and cause injury.

Front row cup holders



The sub-meter has a cup holder for a beverage or water cup.

caution

When using the cup holder, avoid placing small items and other debris in it to prevent the cup holder from getting stuck.

warning

When the vehicle is moving, do not place open beverages or water cups on the cup



Comfort Equipment

holder to prevent the hot drinks in the cups from splashing out and scalding the driver and passengers in the vehicle, or damaging the vehicle and its electrical equipment.

Pass through the compartment

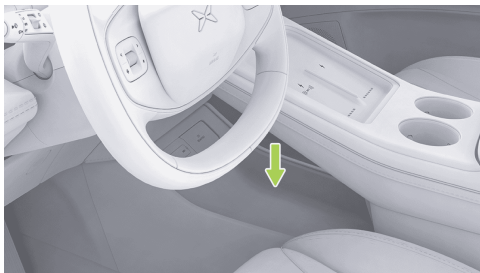

The pass-through compartment is located under the front of the sub-meter.

Master/passenger backrest map pocket



A map bag is located under the back of the main/passenger seat to hold tickets, magazines and more.



Rear center armrest



The rear seat center armrest tilts down for access to the rear cup holders and stowage space.

warning

When the vehicle is moving, do not place open beverages or water cups on the cup holder to prevent the hot drinks in the cups from splashing out and scalding the passengers in the vehicle or damaging the vehicle and its electrical equipment.

trunk



trunk is available for luggage and cargo.

caution

- Do not store fragile, flammable, explosive and other dangerous goods in the trunk to avoid fire, explosion or damage to the goods.
- When storing liquid items, pay attention to the sealing to avoid damage to the vehicle due to liquid leakage. If leakage occurs, please clean it up in time.



- Do not drive the vehicle when it is overloaded to avoid excessive braking distance due to excessive inertia, which may cause accidents.

Luggage compartment net pocket

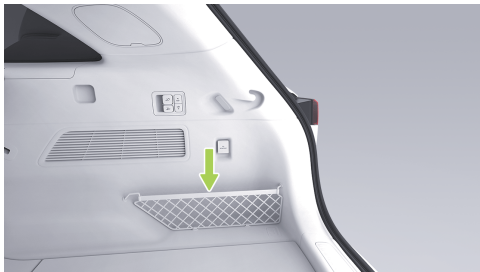

A net pocket is located on the right side of the trunk for water bottles etc.

trunk hooks



The left side of the trunk is fitted with a hook.

caution

Do not hang objects weighing more than 3 kg to avoid damaging the hook.



trunk Groove

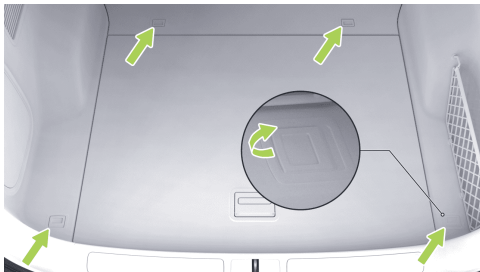

Lift the trunk floor strap to secure loose items.

caution

When not in use, always return the floor clip to the stowed position to avoid injury.

Roof rails

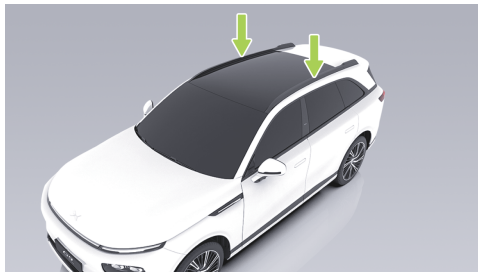

The roof rails are located on both sides above the roof.

The roof rack is a load carrier with a maximum load capacity of 75kg.

Air Suspension *

Introduction

The air suspension supports the following operations:



Comfort Equipment

- Set the height
- Set stiffness
- Easy loading
- Suspension approach

Operation

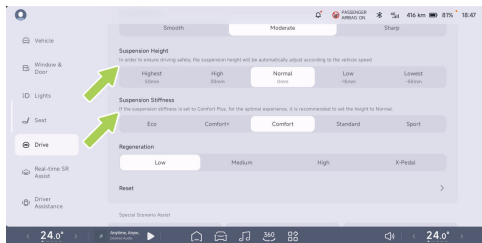

On the “ → Drive” screen in the center control screen, Suspension “**Height**” and “**Suspension Stiffness** can be set”.

Set the height

The air suspension height adjustment ranges from -50mm to 50mm, and when driving, the

vehicle will adjust to the height set by the driver, in conjunction with the vehicle speed. Drive mode, etc., to intelligently adjust the suspension height.

Height gear	Suspension height	Recommended use scenarios
Highest	+50 mm	Poor unpaved roads such as pit, gravel, mud, etc.
Higher	+30 mm	
Normal	0 mm	Everyday driving
Lower	-15 mm	High-speed roads such as viaducts and highways
Minimum, welcome mode	-50 mm	When getting on and off

Comfort Equipment



Easy loading	-50 mm	When loading luggage in the trunk
--------------	--------	-----------------------------------

suspension will make a “click” sound. This is the normal working sound of the dual-chamber air valve.

i Tips

- If the suspension height is adjusted frequently, the system will enter thermal protection mode and will not be able to be adjusted again until the system cools down.
- The suspension height can also be adjusted through the voice of Xpeng.

Easy loading

Set stiffness

Air suspension can be set up for Eco, Comfort+, Comfort, Sport, Standard Five-speed suspension stiffness also automatically increases lateral stiffness at high speeds, preventing roll over.

i Tips

When suppressing the pitch angle and steering roll of the vehicle body during acceleration and deceleration, the air

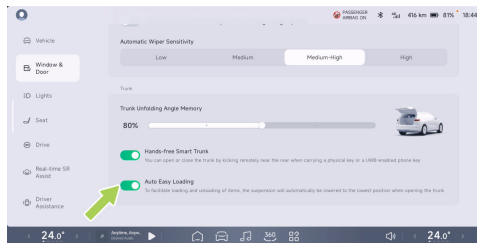



In the center control screen “ → **Window & Door**” interface, Turns “**Auto Easy Loading on/off**”.

The Easy Load function can be manually switched on/off via the Easy Load Switch in the trunk. or open “**Auto Easy Loading in the center control screen**”, The suspension is automatically





lowered to its lowest level when the trunk is opened.



Press , the suspension is lowered to the minimum, press , the suspension is restored to the previous height.

Warnings, Cautions, and Limits

- When lifting the vehicle, **“Suspension Maintenance Mode must be turned on”**. When towing, **“Rescue Mode must be enabled”**. Failure to do so may result in damage to the air suspension.
- Repairs involving the removal and installation of the air suspension must be carried out at the Xpeng Vehicle Service Centre, otherwise damage to the air suspension may result.
- If on the dashboard ,  illuminates, No further driving is allowed, please park the vehicle in a safe area, contact Xpeng Automobile Service Center for service. Failure to do so may result in damage to the air suspension.
- When the vehicle is parked for a long period of time, the suspension height will drop to a certain extent and is normal and the suspension will automatically detect the height and reinflate.
- Before the vehicle is parked for an extended period of time, turn off the suspension approach and easy loading and adjust the suspension height to normal and above without disconnecting the battery. Failure to do so will affect the air conditioning function of the suspension and cause damage to the vehicle.

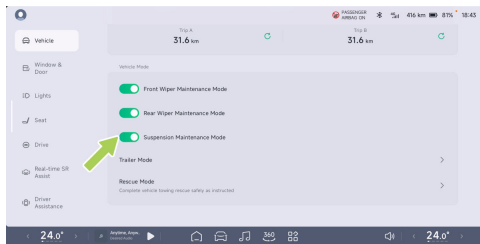

In the central control screen “**Vehicle**” interface, The “**Suspension Maintenance Mode**” can be switched on/off in the next step.

Tow Mode *

Introduction

Your vehicle is equipped with a trailer that can only be used by turning on the tow mode on the central control screen. When towing a caravan, the driver must have the appropriate

driving qualification requirements when towing a caravan.

Before you decide to tow a RV, you should first check your area's regulations for motor vehicles, because the regulations vary from region to region, you need to select the right size of the RV, and consult local service providers before towing.

caution

- When towing a motorhome, please comply with local laws and regulations, and private modifications are strictly prohibited.
- Do not tow a motorhome during the running-in period of a new vehicle.
- When not towing a motorhome, please retract the towing device.
- It is not allowed to tow a motorhome equipped with an electric driving brake system.



Driving instructions

Towing a trailer can affect your vehicle's handling, braking performance, etc. For your safety and the safety of your passengers and for the safe towing of your trailer, follow the driving recommendations below:

- Drive away smoothly to avoid sharp acceleration and heavy braking, especially when driving on slippery surfaces, which can cause loss of vehicle control due to slippage. Side winds and rough roads can cause the vehicle to oscillate, severely affecting the handling of the vehicle. In any case, as soon as you notice a slight sign of the vehicle's oscillation, hold the steering wheel firmly with both hands and slowly reduce the speed immediately. Do not attempt to eliminate oscillation by increasing the vehicle speed.
- Try to avoid the tow tractor unloaded and the trailer load, if this is not possible, because the load distribution is not reasonable, drive at low speed.

- Towing a trailer increases the braking distance of the vehicle. Therefore, the distance to the vehicle in front should be increased.

Instrument indicator lights



Trailer harness OK, suspension/ESP/towbar functioning OK.



Trailer harness OK, possible suspension/ESP/towbar fault, unable to use tow mode correctly.



Trailer harness fault, trailer beacon fault, suspension/ESP/towbar fault, unable to use tow mode normally.



Turn on and off

Turn on

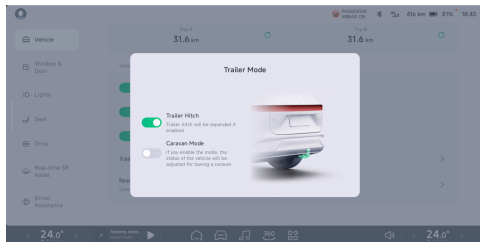

When the vehicle is in P, In the central control screen “ → **Vehicle**” interface, **“Trailer Mode can be switched on/off”**.

caution

- When turning on the trailer hook and trailer caravan mode, a second confirmation is required, and it must be done in P gear.
- During the movement of the trailer hook, the central control screen switch cannot be

used, and it can be restored after it is fully extended or retracted.

- After turning on the trailer hook, other auxiliary driving functions except AEB and FCW functions cannot be turned on. After the trailer hook is completely closed, the auxiliary driving related functions are restored to the state before the trailer hook is turned on.

The trailer caravan mode will not be turned on in the following situations:

- The vehicle is not in P gear.
- The trailer hook is not turned on.
- Suspension failure, ESP function failure.
- When the suspension is in maintenance mode and the suspension leveling mode is turned on.
- When the after-sales sensor is calibrated, the locking mode.
- When the lift mode or marine mode is turned on.



caution

When towing, the towing mode must be turned on, otherwise the vehicle will be damaged.

Close

Disconnect the caravan from the towbar, after disconnecting the electrical connector, click on the center screen towbar switch to exit trailer mode and retract the towbar at the same time.

Electrical connection connector



The electrical connection connector is mounted on the towbar and extends with the towbar when the towbar switch is activated on the center screen. Once the protective cover is open, it is ready for use.

caution

When the electrical connection connector is not connected to the trailer interface, do not use a high-pressure water gun to directly clean the electrical connection connector, as water may enter the connector and cause damage.

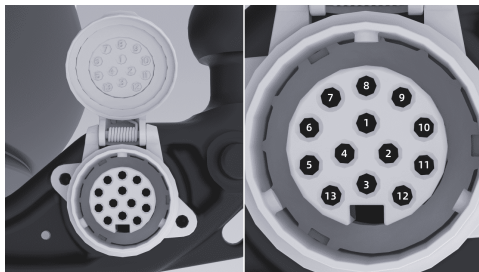

Comfort Equipment



This vehicle is equipped with a 13-pin connection coil, the corresponding standard for the electrical connection ISO 11446: 2004, the specific pin functions as follows:

Pin number	Color	Function
1	Yellow wire	Left turn signal
2	Blue Line	Rear fog or reverse lamp
3	White line	1-8 pin general ground wire
4	Green line	Right turn signal
5	Brown wire	Right road light
6	Red line	Brake lights

7	Black line	Left road light (can be combined with 5)
8	Pink line	Reverse lamps
9	Orange line	Connect battery
10	Gray lines	Battery or refrigerator
11	Black and white lines	10-pin ground wire
12	Blue and white lines	Spare cable
13	Red and white lines	9-pin ground wire



Rear view mirror and bracket

The exterior rear view mirrors of the tow tractor should comply with legal requirements, if not fitted with a suitable trailer rear view mirror.

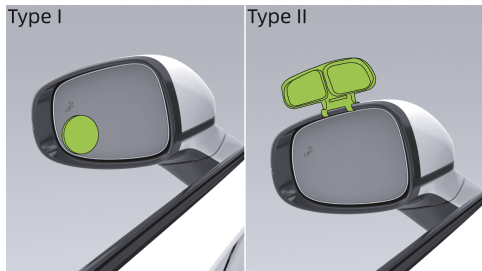

Type one

Stick to the exterior mirror surface;

Type two

Mount the bracket clamp on the frame.

Technical data

The towing capability of the vehicle will depend on the vehicle specification, load, road conditions and trailer specifications, etc. To ensure safe driving, do not overdrive or overdrive, please refer to the table below for specific parameters.

Project	Data
Maximum permissible towing mass (with brakes) [kg]	1500
Maximum permissible towing mass (without brakes) [kg]	750
Max. Tongue weight load [kg]	75

Comfort Equipment



Maximum profile dimensions of passenger car trains (length and width) [mm]	14500*2550*4000
Size limits for a mid-axle trailer permitted to be towed (length and width) [mm]	12000*2550*4000
Maximum size limit for trailer rear suspension [mm]	3500
Electrical connection connector	13-core standard interface according to ISO11446:2004
Connect the ball joint	Meets ECE R55 A CLASS ball joint size requirements

Maximum permissible traction mass

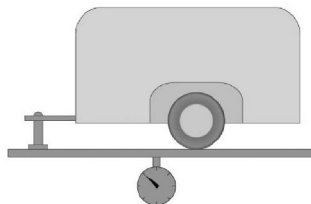

Towing quality refers to the sum of the weight of the trailer and the trailer load.



Maximum tongue weight load

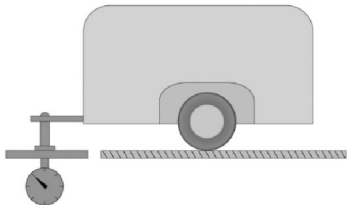

The maximum tongue weight is the maximum vertical load that can be applied to the trailer at the connection to the towbar.

Trailer tail lamp power limit

The trailer tail lamp power does not exceed the following specified values:

- Left/right position lights: 24W.
- Left/Right Turn Lights: 24W.
- Rear fog lamps: 42W.
- Reverse lamps: 42W.
- Brake lights: 42W.

Rear Luggage Load Capacity

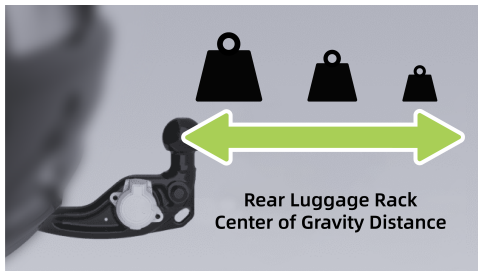

1. If the center of gravity is less than 30 cm from the center of the tow ball, the total weight of the luggage and carrier must not exceed 75 kg.



2. If the center of gravity is less than 60 cm from the center of the tow ball, the total weight of the luggage and carrier must not exceed 35 kg.
3. If the center of gravity is greater than 70 cm from the center of the tow ball, the use of a tow bar for luggage and carriers is strictly prohibited.

Driving Precautions

Drive away

Before driving, make sure that the tire pressures, lights and connections between the tow tractor and the trailer are correct. Switch on the **“Trailer Mode on the central control screen when”** the trailer is connected.

Please safely load the trailer load, ensure that the load is securely fastened to the trailer, and ensure that the trailer is level, otherwise do not drive the vehicle.

Drive away smoothly to avoid sharp acceleration and heavy braking, especially when driving on

slippery surfaces, which can cause loss of vehicle control due to slippage.

Side winds and rough roads can cause the vehicle to oscillate, severely affecting the handling of the vehicle. In any case, as soon as you notice a slight sign of the vehicle's oscillation, hold the steering wheel firmly with both hands and slowly reduce the speed immediately. Do not attempt to remove sway by increasing the speed.

Try to avoid the tow tractor being empty and carrying a trailer load. If this is not possible, drive at low speed because the load distribution is not reasonable.

Braking

Towing a trailer increases the braking distance of the vehicle. Therefore, the distance from the vehicle in front should be increased.

Overtaking

When towing a trailer, the length of the vehicle body plus the trailer becomes longer, so when



overtaking, a longer overtaking distance is required. to return to the original driveway.

Reverse

Reversing when towing a trailer is different from normal reversing and can be difficult and should be done with extra care and practice.

When reversing, turn the trailer to the left by holding the bottom end of the steering wheel with one hand and turning your hand to the left. Turn to the right to turn the trailer to the right. Always reverse at low speeds and ask for assistance if possible.

Turn

When towing a trailer, turn smoothly, avoid jaggging or sudden operation as much as possible, and switch on the turn signals early. When turning, the turning radius must be larger than when the trailer is not towed. This will prevent the trailer from hitting shoulders, road signs, trees or other objects.

Drive on a hill

When towing a trailer on a steep or long incline, slow down early. Driving speed is determined based on trailer weight and slope.

Avoid parking on slopes as much as possible, if this is not possible, place a stop under the towed and trailer tires and apply the parking brake.



Charging Port Cover Open/Closed

Introduction

The charging interface is located on the rear right side of the vehicle.

The charging flap can be opened/closed in the following ways:

- Small P-voice
- Mobile App Bluetooth key
- Smart key fob
- Central control screen
 - Shortcut panel
 - Bottom status bar (if set)
 - “ →Door window”interface

Operation

Via the smart key

Double-click on the smart key “”keys, Opens/closes the “**Charging Port**”.

Via the central control screen

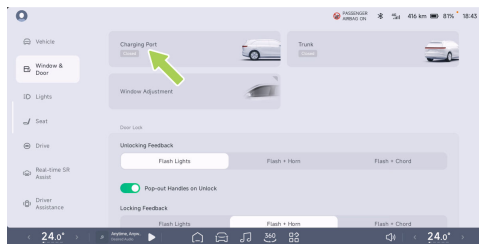

- In the “ →**Window & Door** screen”of the central control screen, Opens/closes the “**Charging Port**”.
- Swipe down from the top of the central control panel, The “**Charging Port**” can be turned on/off in the shortcut panel.



Charging Guidelines

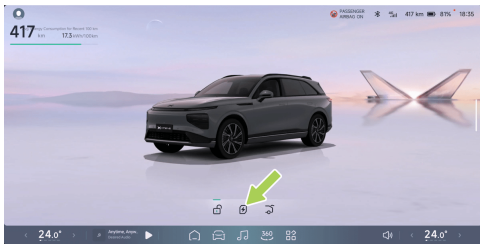

Tap the center control screen “

Charging flap not closed indication

Opening the charging flap displays the charging flap open status on the central control screen

3D model. When driving, the charging flap is not closed and the instrument will prompt a pop-up.

Tips

After charging is completed, please put the sealing cover back into the charging port to prevent foreign objects from falling in.

Charging Limits

Introduction

You can drag the charge limit slider bar to the value you want to set. When the charging limit is reached, the vehicle automatically stops charging.



Operation

Switch on/off via the central control screen

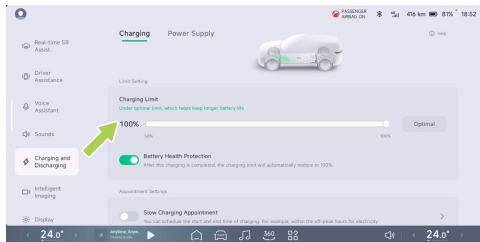

In the center control panel “→Charging and Discharging→Charging”interface, You can set the “Charging Limit”.

- To ensure charging speed and to extend battery life, it is recommended that when charging, Charge limit selection “**Optimal**”.
- If “**Battery Health Protection is checked**”, When the vehicle is powered back up, the charging limits return to their default values.

Charging Operation

Introduction

The vehicle supports both fast/slow charge charging. It can be charged using a national DC or Xpeng Extreme Speed Charge post via a quick-fill port, or with an AC or portable charge gun via a slow-fill port.

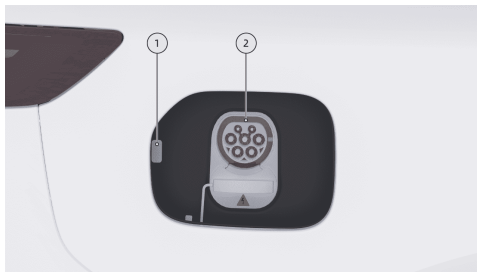

1. Charging indicator
2. Fast/slow filling



i Tips

The slow charging port and the fast charging port share a dust cover. The front and back sides of the dust cover are used for the two charging ports respectively. When charging, please place the dust cover on the charging port without a charging gun to prevent foreign objects from falling in.

Charging status display

The vehicle can be charged with the following indications during charging:

1. Instrument cluster
2. The central control screen 3D charge/discharge interface
3. Mobile App Bluetooth key

Operation

Charging work procedure

1. Park the vehicle and shift the vehicle into Park (P).

2. Open the charging flap.
3. Remove the charge port dust cover.
4. Press the button on the charge gun to remove the charge gun protective cover.



5. Insert the charge gun vertically into the charging port and hear a click to indicate that the charge gun is in place.

i Tips

If the AC charging gun is not plugged in firmly, the App will push a reminder of abnormal plugging to prevent the vehicle



from being unable to start charging after leaving the vehicle.

⚠ warning

Do not shake the charging gun when inserting it.

6. After following the instructions of the charging pile, start charging.
7. When you need to end charging halfway, tap the **“End Charging”** button on the central control screen to end charging.
8. When charging is complete, press and hold the unlock button on the charge gun to unplug the charge gun.
9. Close the charging port dust cover and close the charging port cover.
10. Put the charge gun back into the home position of the charge post.

⚠ warning

- The vehicle may affect medical or implanted electronic devices during charging and

discharging. Please consult the electronic device manufacturer before charging and discharging.

- If a fault occurs during charging, a fault prompt will pop up on the charging interface. Do not try to charge again. Please contact the Xpeng Service Center immediately.

⚠ caution

- If the charging gun cannot be pulled out, you can unlock the charging gun through the emergency unlocking switch on the central control screen or the emergency unlocking pull ring on the trunk.
- You must strictly follow the operating procedures of the charging pile to charge or stop charging. It is forbidden to plug and unplug the charging gun at will during the charging process.



i Tips

- During charging preparation, the system will heat the power battery and automatically enter charging after reaching the specified state.
- When charging with a charging gun in a low temperature environment, the charging efficiency may decrease or charging may fail. When the power battery is exhausted and charging in a low temperature environment, after connecting the charging gun, the system will first heat the power battery to a suitable temperature and then charge the power battery.
- Before fast charging in a low temperature environment, it is recommended to use the navigation intelligent heat preservation function.
- Depending on different factors, such as the temperature outside the vehicle, the battery usage time or the charging current, the charging time may vary.

Warnings, Cautions, and Limits

- When removing the charge gun from the charge post, hold the charge gun firmly with both hands to prevent the twisted charge cable from bouncing onto the person, causing injury.
- Before charging, check that the charging ports, guns, charging plugs, etc. are dry and do not charge the charging devices or when your hands are wet.
- The charging cable must be free from distortion when charging.
- If the charging device is corroded or damaged, such as the metal terminals of the charging gun are deformed, skewed, When the plastic body of the plug is deformed, cracked and other abnormal conditions, the charging is prohibited.
- In case of an emergency during charging, press the emergency stop button on the charging device to stop charging.

Charging Guidelines



- It is recommended to stop charging the vehicle during thunderstorms, lightning may cause damage to the charging equipment.
- It is recommended to choose a cool, covered pile to charge, to avoid rain or snow when plugging or unplugging the tip of the charge gun.
- To insert/remove the gun, unlock the vehicle, insert/remove the gun vertically, no diagonal plug, Shake.
- Stop charging immediately if there is a strong and irritating smell coming from the charging port during charging.
- Never allow minors to touch or use the charging device.
- If you find foreign objects, such as dirt or large particles, such as metal sockets, charging guns or charging plugs, you need to clean and recharge the vehicle after it has been powered down.
- If you have a pacemaker or cardiovascular defibrillator and electronic devices such as an internal analgesic pump, insulin pump, hearing aid, etc., do not stay in the vehicle or enter the vehicle to collect items while charging. Failure to do so may affect the functioning of the electronic medical device, resulting in personal injury or death.
- Do not disassemble or modify the charging port or the charging cable.
- After charging, take care to close the charging flap promptly to avoid rain, snow or other foreign objects.
- Due to the differences in the understanding of charging standards of various brands of charging pile manufacturers, and different levels of maintenance of charging pile products, there may be the use of individual charging pile failed to charge successfully, if such phenomenon, Try replugging the gun or replacing the charging studs to charge.



Emergency Unlock of the Charging Port

Operation

Central control emergency unlocking

If the charge gun still fails to pull out after the vehicle has been unlocked several times, the charge gun can be pulled out as follows:

In the central control screen “🚗 → **Charging and Discharging** → **Help** → **Emergency Unlock Gun**” interface, Tap “**Unlock Charge Gun**” to manually unlock the charge gun and pull it. If charging is in progress, unlocking the charge gun will end charging early, please confirm and proceed.

i Tips

When the charging port cover is closed or a DC charging gun is used for charging, the central control screen does not display the "Unlock charging gun" button.

Physical emergency unlock

If the charger gun still fails to pull out after several attempts at the emergency unlock key of the central control screen, pull the charger gun out by plugging it into place as follows:



1. Open the rear trunk and use a suitable tool to open the rear trunk service cover.



2. Locate the emergency unlock ring of the charging port, pull the ring, unlock and pull out the gun.

caution

- The emergency unlocking ring can be used to unlock the charging gun only after the vehicle has finished charging and the central control screen exits the "charging/charging heating" status display.
- The emergency unlocking ring of the charging port is suitable for emergency situations. Frequent use may damage the

emergency unlocking ring of the charging port or the charging device.

- If the charging gun cannot be unlocked using the emergency unlocking ring of the charging port, please contact the Xpeng Service Center in time.

Slow Charge

Introduction

The Slow Charge Scheduled Charging feature sets the vehicle charging start and end times, saving on charging costs by taking advantage of the nightly trough rate.



Operation

Switch on/off via the central control screen

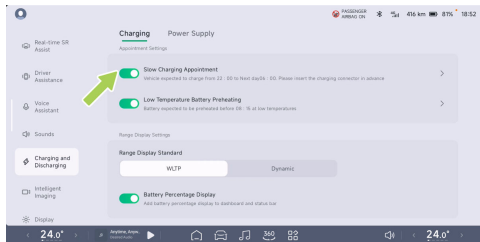

In the center control panel “ → **Charging and Discharging** → **Charging**” interface, to start the “**Slow Charging Appointment**”, and set the charging time.

caution

When using slow charging, you need to lock the car after plugging in the gun to prevent the charging gun from being unplugged by others.

Low temperature battery warm-up

Introduction

Low temperature battery preheating improves vehicle range in cold conditions, sets daily departure times and intelligently preheating the battery before departure time.

Operation

Switch on/off via the central control screen

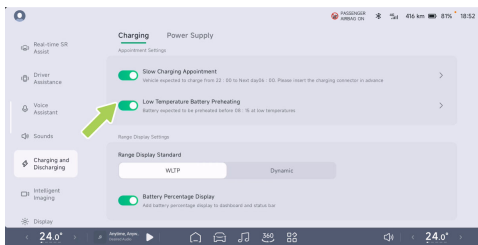

In the center control panel “ → **Charging and Discharging** → **Charging**” interface, “**Low**



Temperature Battery Preheating can be turned on, and set the warm-up time.

i Tips

The time set for low temperature battery preheating is the completion time.

! caution

- When using low-temperature battery preheating, you need to lock the car after plugging in the gun to prevent the AC charging gun from being unplugged by others.
- After the power battery preheating is completed, it is recommended to use the vehicle as soon as possible. Long-term parking will reduce the heating effect.
- If the power battery temperature is high, the low-temperature battery preheating function will not be enabled.
- If slow charging is used at the same time, please make sure that the preheating time is set later than the scheduled charging time.

- Low-temperature battery preheating will slightly increase the power consumption of the AC charging pile. Please use it as needed.
- If the activation fails, please check whether the activation conditions of the function are met. If there is any abnormality, please contact the Xpeng Service Center.

Navigation Intelligent Warm

Introduction

When navigating to the fast charging station in the central control screen, the vehicle controls the power battery temperature at the optimum charging interval, reducing the charging time.



Operation

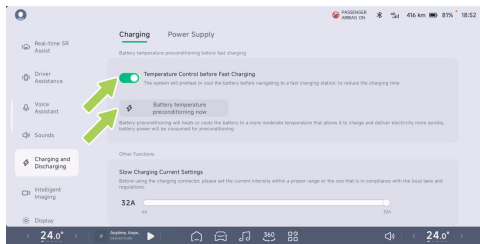

In the center control panel “ → **Charging and Discharging** → **Charging**” interface, “**Temperature Control before Fast Charging**” can be switched on/off in the next step.

When navigating to the familiar charging station is not switched on, “**Battery temperature preconditioning now**” can be manually or voice on/off function.

Tips

This function will heat or cool the power battery, consuming part of the remaining power.

Discharge V2L Externally

Introduction

The vehicle can use a discharge device to supply power from the power battery to other appliances, with a discharge voltage of 220V and a maximum power of 6kW.

Operation

Set the external discharge limit

In the center control panel “ → **Charging and Discharging** → **Power Supply**” interface, to set the “**Power Limit**”, The power supply stops automatically when the power battery reaches the limit.



External discharge work procedure

1. Open the charging flap.
2. Remove the charging port sealing cap.
3. Plug in the discharge device and the vehicle slow charge charging interface to start the power supply.
4. Power supply is complete, tap **“End Power Supply”** on the central control screen.
5. Unplug the discharge device.

caution

When you need to end the discharge operation, please first click the **“End Power Supply”** button on the central control screen, and then unplug the discharge device, otherwise it may cause damage to the vehicle.

Notices and Limitations

Tips

- When the power level is less than 20%, the external discharge function is not available.

- The external discharge equipment (discharge socket, etc.) is not standard and needs to be purchased by yourself.

warning

- Do not use the external discharge function when the external electric appliance or charging plug is damaged.
- Never allow minors to touch or use the charging plug, and keep them away from the charging plug during use.
- When the power supply is abnormal, please deactivate the external discharge function immediately.
- Do not touch the plug pins of electrical appliances and the socket of the charging plug.
- Do not use shoddy products, medical or health care electronic devices.
- Do not use products that require a continuous power supply, such as medical equipment. The power supply may be



Charging Guidelines

interrupted depending on the vehicle's condition.

- Put the power plug fully and use the qualified plug that meets the standard. If you use worn, corroded or broken plug or improper plug, it might be a cause of malfunction.
- Do not use high power home appliances that pull current for a long time such as air conditioning, washing machine or dryer, etc.
- Do not hang the home appliances on the adapter.
- For devices used outdoors in a vehicle, use a product with a waterproof function or use it in a waterproof environment.
- Do not use in environments with rain or high humidity. (Electrical appliances, multi-outlets, cord extension cables, etc.)
- If there is a risk of lightning, do not use the V2L function outside the vehicle.
- Do not connect multiple portable multi-outlets.

- When using an extension cable, if the cable is twisted or overlapped by itself, it may cause a fire. Be sure to use the cable without twisting it.

Battery Health Protection

Operation

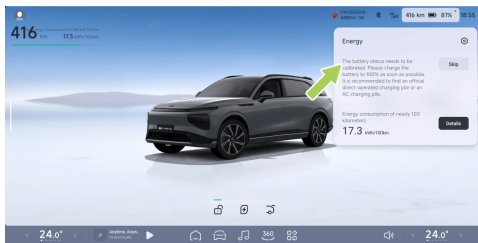

The battery needs to be calibrated by fully charging. When the status bar on the central control screen prompts **“The battery status needs to be calibrated.”** time, Fill the battery to

Charging Guidelines



100% as soon as possible and perform a battery calibration.

i Tips

When calibrating the battery, it is recommended to use an official direct-sale charging station or an AC charging station.



Routine Maintenance

Intelligent Driving Assistance - Hardware

Radar

For correct radar operation:

- Keep the radar surface clean and free of snow, ice, water, dust and other foreign objects.
- When foreign objects are found on the radar surface, wipe with a soft cloth or wash with water (low water pressure).

Camera

For proper camera operation:

- Keep the camera surface clean and free from snow, ice, water, dust, etc.
- Keep the front window glass clean.
- The window glass in front of the camera must be kept clean and clear of objects between the camera and the window glass.

- When foreign objects are found on the camera surface, wipe with a soft cloth or wash with water (low water pressure).

Open/Close the Front Compartment Cover

Operation

Open the front door



1. Pull the front compartment lid handle on the lower left side of the instrument panel twice

Routine Maintenance



in succession, the front compartment lid pops up slightly to complete unlocking.



2. Open the front compartment lid upwards and the support bar automatically supports the front compartment lid.

Close the front compartment cover.

1. Lower the front door until the front door latch contacts the latch.

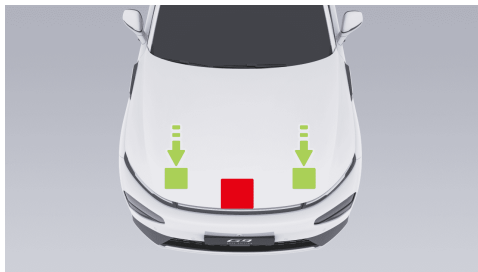

2. Place both hands on the front side of the front compartment cover (green area above) and press to close the front compartment cover.
3. Once closed, check that the front compartment lid is securely latched and the instrument cluster will indicate that the front compartment lid is open and closed.

warning

- Before driving, make sure the hood is completely closed and both side locks are fully locked.



Routine Maintenance

- Apply pressure only to the green area shown in the figure. Applying pressure to the red area may cause damage.
- Do not close the hood with one hand to avoid concentrated force, which may cause dents or bends.
- Do not press the front edge of the hood to avoid bending the edge.

Coolant

Introduction

warning

- To add coolant, you need to open the front hatch. Please contact the Xpeng Service Center to operate to avoid accidental contact with high-voltage components and personal injury.
- Never unscrew the reservoir cap when the cooling system and coolant reservoir are at high temperatures. Under the pressure of steam and boiling liquid in the high-

temperature cooling system, once the reservoir cap is unscrewed, the boiling liquid will splash out and burn people.

Check the coolant level during the specified service period.



Look at the level mark on the side of the coolant reservoir:

- MAX: Upper limit flag
- MIN: Lower limit mark

Routine Maintenance



Coolant level should be between the MIN mark and the MAX mark, if below the MIN mark, add Xpeng Motors approved coolant in a timely manner.

Operation



1. Using a suitable tool, remove the front compartment trim panel and the storage box, i.e. the visible coolant reservoir.



2. Unscrew the reservoir cap and top up the coolant.

In order to maximize the performance and life of power batteries, motors, and air conditioning systems, the cooling system is selected with a specific type of coolant (different freezing points are selected depending on the minimum temperature of the location).



Brake Fluid

Introduction

If the fluid level in the brake fluid reservoir is below the specified level, the brake light on the instrument cluster will sound an alarm. If the alarm is sounded while driving, stop the vehicle side by side while ensuring safety, do not continue driving, and contact the Xpeng Automobile Service Centre immediately.

warning

- If you find that the brake pedal is loose or the brake fluid is significantly depleted, please contact the Xpeng Service Center immediately. Driving under these conditions may result in extended braking distance or complete brake failure.
- The brake fluid packaging container is marked with the brake fluid specifications. In any case, brake fluid that meets the vehicle specifications must be used, and new brake fluid must be used. Used

brake fluid or inappropriate brake fluid will inevitably deteriorate the braking effect and even cause the brake system to fail. It is recommended to use the original brake fluid of Xpeng Motors.



Look at the level marks on the side of the brake fluid reservoir:

- MAX: Upper limit flag
- MIN: Lower limit mark

The brake fluid level should be between the MIN mark and the MAX mark, if below the MIN mark,

Routine Maintenance



top up Xpeng Motors approved brake fluid in a timely manner.

warning

- Add brake fluid until the fluid level is close to MAX (but do not exceed the MAX line). After adding brake fluid, install the cap.
- Brake fluid is a toxic substance. When discharging or disposing of waste brake fluid, relevant environmental regulations must be followed.

Operation



1. Using a suitable tool, remove the reservoir upper trim.
2. Clean the reservoir cap first to prevent dirt from entering.



3. Unscrew and remove the reservoir cap.
4. Top up the brake fluid to the approved Xpeng Motors brake fluid until the brake fluid is close to the MAX mark.

Notices and Limitations

warning

- Use new brake fluid in an airtight, sealed bottle. Never use brake fluid from a used or opened container. Brake fluid absorbs water and reduces braking performance.

- Brake fluid is highly toxic. Keep containers sealed and out of reach of children. If accidentally ingested, seek medical attention immediately.
- Brake fluid can damage painted surfaces. Immediately absorb spills with an absorbent cloth and wash with a car detergent mixed with water.
- The brake fluid container may not be accurately checked because of components in the front compartment of some models. If necessary, contact the Xpeng Motors Service Center for help.
- The brake fluid level may drop slightly during use due to automatic adjustment due to wear of the brake pads. This is normal and there is no need to worry. However, if the level drops significantly in a short period of time, or drops below the "MIN" mark, or if the reservoir needs to be refilled frequently, it indicates that there is a leak in the brake system. Contact the Xpeng Service Center



as soon as possible to check the brake system.

- If the level drops below the specified height, the warning light will light up. The instrument cluster may display relevant text information, prompting or warning the driver to perform certain operations immediately. In this case, you must stop the car immediately and do not continue driving, and contact the Xpeng Service Center as soon as possible to check the brake system.
- If the brake system warning light does not go out or lights up while driving, it means that the brake fluid level is too low. To prevent accidents, you must stop the car immediately and do not continue driving. You should contact the Xpeng Service Center as soon as possible.
- Brake fluid is hygroscopic. During use, the brake fluid continuously absorbs moisture from the surrounding air. If the water content of the brake fluid is too high, it will corrode the brake system and greatly

reduce the boiling point of the brake fluid. Air blockage may occur during emergency braking, reducing the braking effect.

- Never store brake fluid in empty food containers, bottles or any non-original brake fluid containers, otherwise, the brake fluid may be mistaken for food, leading to poisoning accidents!

Add Windshield Washer Fluid

Introduction

Check cleaning fluid regularly, If the instrument low washer fluid level indicator is found to  be illuminated, The washer fluid level is too low and should be added to the reservoir in time.

Operate the washer regularly and check that the nozzles are not clogged and that the spray is correct.



Operation



1. Clean the reservoir cap first to prevent dirt from entering.
2. Open the reservoir cap.
3. Fill until the fluid level is visible below the filler opening.

Replace Wiper Blades

Introduction



With the vehicle in P position, leave the wipers off. In the central control screen “ →Vehicle” interface, Open “**Front/Rear Wiper Maintenance Mode**”, The wiper arms will operate to the service position and return automatically when the wiper service mode is switched off.





caution

Before replacing the wipers, the wiper maintenance mode must be turned on with the front hood and main driving door fully closed, otherwise the vehicle will be damaged.

Operation

Replace the front wiper blade

1. In the central control screen “”
→**Vehicle**”interface, To open “**Front Wiper Maintenance Mode**”, The wiper arms will run to the service position.
2. Raise the wiper arm, press the lock button and pull the wiper blade out in an upward direction.
3. Reverse the procedure to install the new wiper blade back into the wiper arm and “”install into place with a click.
4. Lightly return the wiper arm to the windshield.
5. Close “**Front Wiper Maintenance Mode**”.

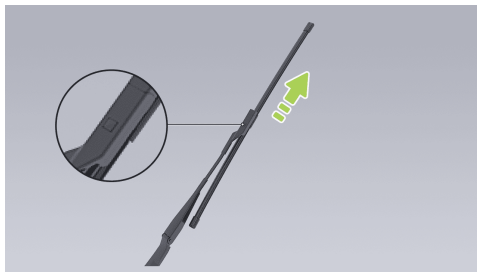

Replace rear wiper blade

1. In the center control screen “”
→**Vehicle**”interface, Open “**Rear Wiper**



Maintenance Mode, The wiper arms will run to the service position.

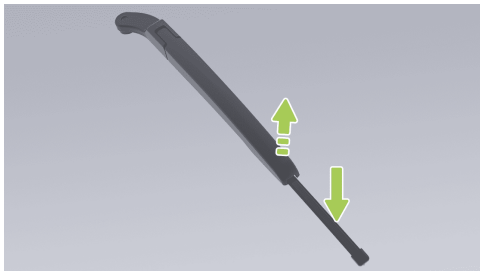

2. Remove the wiper blades by pressing and holding the wiper blades and pulling the wiper arms upwards along the wiper arms and blade connections.
3. To install, raise the wiper arm, snap the raised position on the new wiper blade into the snap slot on the wiper arm, and then gently return the wiper arm to the rear window glass.
4. Close **"Rear Wiper Maintenance Mode"**.

i Tips

- If you need to replace the wiper blade, it is recommended to go to the Xpeng Service Center for replacement.
- When cleaning the glass, wiper blades or replacing wiper blades, please lift the wiper arm when lifting the wiper, and do not grab the wiper blade directly to avoid deformation of the wiper blade, which will affect the wiper noise and scraping performance.

Power Battery

Introduction

The power battery is mounted on the underside of the vehicle, so drive carefully!

! caution

- Be careful when driving on special roads such as mud, potholes, curbs, high and wide speed bumps, and sidewalk slopes to avoid



chassis collisions that may cause scratches or damage to the power battery.

- Be careful when driving on roads with deep water to avoid short circuits, leakage, or damage to the power battery due to excessive contact with water.

warning

If you feel the chassis is scratched or the power battery emits an odor, you should stop using the vehicle immediately and contact the Xpeng Service Center.

Range

Range is dependent on power battery remaining, vehicle range and time, ambient temperature, road conditions, Driving habits (air conditioning, driving mode, energy recovery level), total vehicle load and other factors.

Ambient temperature

The ambient temperature affects the performance of the power battery. The°C

°Cvehicle is required to be used in an ambient temperature range of -30 to 55. To maintain the performance of the power battery and to extend the life of the power battery.

caution

Do not expose the vehicle to temperatures above 55°C or below -30°C for a long time.

Power battery care

The power battery will slowly discharge itself even when the vehicle is not in use. A low power battery reduces the life and performance of the power battery and affects the range of the vehicle. Therefore, when the vehicle is parked for a long time, should check the power battery residual charge, so that the charge remains between 30% and 60%, if the charge is insufficient, please charge to meet the parking needs before placing.

You can refer to the table of different charge and parking time to ensure full parking:



Range or battery	30%	50%	60%
Number of days to park	≤ 90	≤ 150	≤ 180

It is recommended to check the power supply every 3 months, if the battery charge is too low, you need to charge it in time, otherwise the power battery performance will be reduced due to the lack of power.

The life of the power battery is also affected by the ambient temperature. When the ambient temperature is low, the vehicle's range decreases and the charging time increases.

i Tips

- Recommended charging working environment temperature: 0 ~ 45°C. When the working environment temperature is below 0°C, the charging time will be extended.

- Parking the vehicle in a high temperature or severe cold environment for a long time will accelerate the loss of the power battery. It is recommended to park in a cool, dry and ventilated place, away from heat sources (such as heating pipes) and low-lying areas, away from flammable and explosive items and corrosive substances.
- Avoid wading the vehicle for long distances or for a long time.
- Never discharge the power battery completely.
- When parking the vehicle for a long time, do not disconnect the battery cable, otherwise the vehicle cannot recharge the battery and the air suspension cannot automatically refill air.

Maintenance of lithium iron phosphate batteries

The vehicle power battery is a lithium iron phosphate battery, please follow the recommendations below for a more accurate



estimate of the range and also for the health of the power battery.

- Charge the battery to 100% as soon as possible after collection (the first three times it is recommended to charge the battery to 100% using a fast charge) and on subsequent use it is recommended to always keep the charging limit set to 100%. And at least 100% full every 2 weeks or 1000 km (fast and slow charge unlimited).
- Recharge when the vehicle has a range of less than 30 km or has been parked for more than a week.
- At low winter temperatures, it is recommended to maintain a range of at least 100km.
- Reduce vehicle power consumption by avoiding prolonged sentry mode or boot 12V delay power down when parking.

Charging Base

Introduction

Under normal use, use a high-pressure air gun or brush to clean it every week. If conditions do not allow, use a dust-free cloth or cotton swab to clean the charging base and charging gun.

warning

- It is strictly forbidden to use sharp objects such as screwdrivers and tweezers to touch the charging gun pins and charging sockets to avoid damaging the pins and sockets.
- If foreign objects enter the deep part of the charging station, they must be cleaned by professionals.

caution

If you cannot draw the gun normally after charging, please do not draw the gun violently. Please try to use the charging port for emergency unlocking or contact Xpeng service center.



Tires

Introduction

Checking and maintaining tires

Please check the tire pressure regularly. If it needs to be inflated, be sure to adjust it according to the tire pressure label on the B-pillar on the driver's side.

Regularly check the tread for abnormal wear, nail punctures, etc. Regularly check the sidewall for bulges, cuts, etc.

Tire wear

Sufficient tread depth is crucial to tire performance. During normal driving or driving in harsh conditions, continued use of tires with shallow treads or showing signs of wear can easily lead to slipping, increased braking distance, steering failure, and tire rupture, which can easily cause accidents and should not be used.

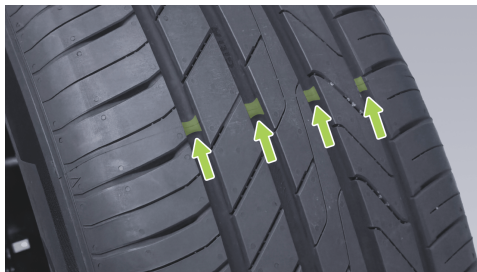

i Tips

The wear marks are schematic diagrams for reference only. Please refer to the actual vehicle.

The tread grooves have transverse ribs evenly distributed along the circumference of the tire, and wear marks with a height of 1.6 mm. The wear marks are used to indicate whether the tire is severely worn. Tires worn to the wear marks must be replaced.



warning

- Tires must be replaced when they are worn to the wear mark.
- Even before reaching the wear mark, severely worn tires will reduce their safety and performance. Especially on slippery roads, the risk of skidding will increase, seriously affecting driving safety.

In order to reduce tire wear and extend tire service life, you can maintain the tires according to your driving habits and road conditions:

- Avoid violent acceleration.

Friction Plates

Introduction

It is recommended to check the friction discs for wear to the warning discs every service or long travel.

If a brake noise occurs during braking, it is recommended to inspect the friction discs and replace them if worn to the warning position.

The friction discs need to be replaced with the original parts, and when the friction discs are replaced, copper oil should be applied evenly where the lugs of the friction discs come into contact with the calipers.

Vehicle Cleaning

Exterior cleaning

Exterior cleaning

Always wash the car to help protect the appearance of the vehicle.

Wash the car in a cool place, wait until the vehicle has cooled down sufficiently, then wash the vehicle to avoid direct sunlight causing damage to the paint.

When using an automatic car wash, always follow the instructions of the car wash operator.



Do not flush the vehicle with water toward the edge of the glass.

Wash the vehicle in the winter, take care to dry the seams around the door handles to prevent the risk of freezing.

Corrosive substances (bird droppings, resins, insects, asphalt spots, Paving salt, industrial dust, etc.) to avoid damage to vehicle paints.

When washing the exterior of the body, follow these steps:

1. Prepare before cleaning

Close all doors, boot and front compartment lid and check the charging flap is fully closed.

2. Rinse thoroughly

Flush body dirt and gravel with hoses before washing. Rinse areas that are prone to dust, mud or paving salt (e.g. wheel arches and panel seams).

3. Hand wash

Wash the exterior of the vehicle by hand with a soft cloth dampened with a good quality mild car cleaner in cold or warm water.

4. Rinse with clean water

After cleaning, rinse with water to prevent any soapy water remaining on the surface from drying out.

5. Dry the cloth

⚠ caution

- Do not use hot water and detergent.
- If you use a high-pressure washer, keep the nozzle at least 30 cm away from the surface of the car body, keep the nozzle moving, and do not spray water continuously at a certain part. Do not spray water at the charging port.
- When washing the car in a low-temperature environment or parking outdoors on snowy days, the active grille blades may not work properly due to ice. The combination instrument prompts that the active grille is



faulty. This is a normal phenomenon and does not affect the normal use of the vehicle. After normal driving for a period of time (about one hour) or thawing with a hot air gun, the fault will automatically disappear. If the fault still exists after the blades are thawed, please contact the Xpeng Motors Service Center for inspection.

- Do not spray water directly from the hose to the car window or door seal or spray water into the brake parts through the wheel hub hole.
- Avoid using lint or coarse cloth, such as car washing gloves.
- Do not use chemical tire cleaning agents, otherwise it may damage the surface of the finished wheel.
- When washing the vehicle, please avoid using ethanol or ethanol-based cleaning fluids, otherwise it may cause damage to the surface of parts such as the lampshade, paint and wipers.

Cleaning and maintenance of external plastic parts

Usually clean with clean water and a soft cloth, a soft brush.

Window and mirror cleaning

Clean the window glass and mirrors with an alcohol-based glass cleaner, then dry the glass surfaces with a clean, lint-free cloth.

Any wax that remains on the glass after body surface maintenance should be removed using a special cleaner and cloth to avoid scratching the wiper blades.

A small brush can be used to remove snow from the windows and mirrors.

Use a de-icing spray to remove ice build-up, or use a de-icing shovel, but special care is required to avoid damaging components. Ice must also be scraped in the same direction when used.



caution

- Do not use warm or hot water to remove ice and snow from the windshield and rearview mirrors, otherwise the glass may burst.
- If there is residual rubber, grease and silicone on the glass, it must be removed with a special window cleaner or silicone cleaner.

Care of the seal

Use a soft cloth to remove surface dust and dirt when maintaining the seal. Apply the rubber seal regularly with a special protective agent.

Cleaning of wiper blades

Regularly inspect and clean the edges of the wiper blades and check for rubber cracks, cracks and roughness. If damaged, please contact Xpeng Automobile Service Center for replacement.

Contamination on the wiper blade may reduce the wiper blade effect. Contaminants include

ice, wax washing, cleaning solutions containing bacteria or water repellent, bird droppings, Leaves and other organic substances.

Wash the wiper blades as follows:

- Clean the window glass with a non-abrasive glass cleaner.
- In the central control screen “ →**Vehicle**”interface, Open “**Front/Rear Wiper Maintenance Mode**”in the next step.
- Lift the wiper arm slightly from the windshield, close enough to the wiper blade, then wipe the blade clean using isopropyl ethanol or washer fluid.
- If the wiper blades remain invalid after cleaning, the wiper blades may need to be replaced.

caution

- Be careful when lowering the wiper arm to prevent it from falling and hitting the windshield.



- The surface of the wiper blade is coated with a layer of graphite, which can make the wiper smooth and without scraping noise. Cleaners containing solvents, hard sponges and sharp tools will damage the graphite layer. Damage to the graphite layer will increase the scraping noise of the wiper and should be replaced in time.
- In winter or cold conditions, be sure to check whether the wiper blade is frozen to the windshield before using the wiper. If so, de-ice it first, otherwise it will cause damage to the wiper blade and wiper motor.
- When cleaning the glass, wiper blade or replacing the wiper blade, please lift the wiper arm when lifting the wiper, and do not grab the wiper blade directly to avoid deformation of the wiper blade, which will affect the wiper noise and scraping performance.

Windshield glass cleaning

Clean the windshield with a special cleaner.

Contamination on the window glass may affect the hydrophilic properties of the glass, please clean it up. Contaminants include dust film, bird droppings, leaves and other foreign matter.

caution

- Do not use cleaning products containing ammonia or chlorine, such as household window glass cleaners, as this will accelerate the aging of the wiper rubber strips.
- Do not use hydrophobic materials (such as waxing, crystal coating, etc.) to clean the windshield, as this will increase the hydrophobicity of the glass surface and affect the cleanliness of the windshield.

Interior cleanliness

Check and clean the interior regularly to keep the exterior clean and up to date and prevent premature wear.



caution

- It is recommended to use automotive products that do not contain plasticizers. If the plasticizer content of automotive products is too high, it will react with the PU material interior, causing the interior to bulge, etc.
- To avoid interference with the pedals, make sure the driver's foot pad is properly fixed and do not stack foot pads on it. The foot pad should always be placed on the surface of the vehicle carpet.
- The use of solvents (including alcohol), bleach, citrus cleaners, naphtha, silicone-based products or additives will damage the interior.
- Substances with static electricity can cause damage to the central control screen and instrumentation.
- Do not use wet wipes, wet cloths, detergents, etc. to wipe the door guards, and pay attention to protection during vehicle use

(such as rainy days, car washing), try to avoid water ingress to the door guards, otherwise it may cause internal electrical component failures, etc.

- If any damage is found to the airbag or seat belt, please contact the Xpeng Motors Service Center immediately.
- It is strictly forbidden for any water, detergent or fabric to enter the seat belt device.

Interior glass

DO NOT scratch or use any abrasive cleaning solution on the glass or mirror. Failure to do so may damage the mirror reflectors and rear window heating elements.

Instrument table and plastic finish

Do not polish the surface of the instrument panel, the polished surface is reflective and may interfere with the driving vision.



Clean the seat

If the seat is soiled, wipe gently with a soft cloth dampened with warm water and mild soap, and then dry with a soft, lint-free cloth.

Seat belt

Pull out the seat belt and wipe, do not use any type of cleaning agent or chemical detergent. Pull out the seat belt to allow it to air dry.

Car carpet

Use a vacuum cleaner with a soft brush head to remove dust and scale. For stubborn stains, try removing them first with water or soda. Before cleaning, use a suitable method to remove soiling:

- For liquid soiling: Gently wipe the remaining soiling with a paper towel so that the soiling is as soaked as possible and adsorbed to the paper towel.
- For solid dry soiling: Remove as much manually as possible and then use a vacuum cleaner.

Central control screen and instrument

Clean the central control screen and the instrument with a soft, special, clean, lint-free cloth. Do not use cleaning agents such as glass cleaners, damp rags or dry, static-coated rags such as a recently cleaned ultra-fine microcloth.

In the central control screen “ → **Display screen**” or via the central control screen shortcut panel, Enable “**Screen Cleaning**” before wiping the central control screen. The buttons are not activated and settings are changed.

caution

It is prohibited to use corrosive liquids such as acids, alkalis, deoxidizing cleaning agents, sodium hypochlorite (84 disinfectant) to clean the central control screen.

Chrome plated and metal surfaces

Polishing agents, abrasive cleaners, or hard cloths can damage the finish of the chrome and metal surfaces.



Floor mats

To extend the life of car carpets and ease cleaning, use genuine Xpeng Automotive approved floor mats. Clean the floor mats regularly and make sure they are properly installed. Replace the floor mats if they are excessively worn.



Emergency Devices

Emergency device information

Hazard warning lights



In the event of an emergency while driving, the hazard warning lamps can be activated by pressing the hazard warning lamp switch and the turn signal lamps flash. Press the switch again to switch off the hazard warning lights.

caution

The hazard warning lights can be turned on regardless of whether the vehicle is powered on or off.

Emergency power down switch



How to do it- [See 197 page](#) .



Trunk emergency open switch

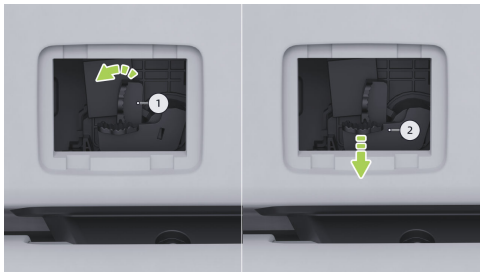

How to do it- [See 188 page](#)

Boot emergency



1. Warning triangle.

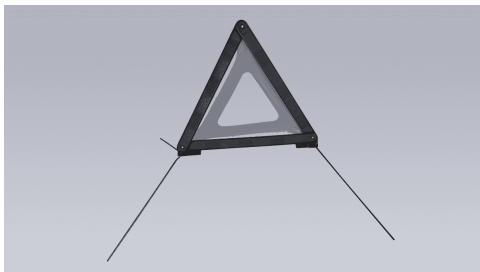

In an emergency, switch on the hazard warning lights, wear a reflective vest, remove the warning triangle and deploy to the rear of the vehicle. Alerts rear vehicles to deceleration avoidance. The placement is shown in the table below.

General roads	General roads	Motorways
Daytime	Night	Motorways
≥50m	≥80m	≥150m

warning

Do not set up warning signs without wearing a reflective vest.

2. In-vehicle kit:
 - Type 1: Tow hook, nut cover removal clip, inflatable tire repair emergency tool.
 - Type 2: Tow hook, wheel center cover removal hook, inflatable tire repair emergency tool.

Tips

After using the trunk emergency device, please put it back to its original place.

3. Reflective Vest: When you have a problem driving your car and need to be parked, remove the Reflective Vest from under the loadspace cover and wear it neatly.

Tips

- When wearing a reflective vest, please wear the side with the reflective material on the outside.



Emergency Rescue

- If the reflective vest is damaged or seriously dirty, please replace it with a new one in time.

warning

When handling a vehicle accident, no matter what the lighting conditions are, be sure to wear reflective clothing as required to attract the attention of passers-by or other vehicle drivers.

Raise the vehicle using a jack

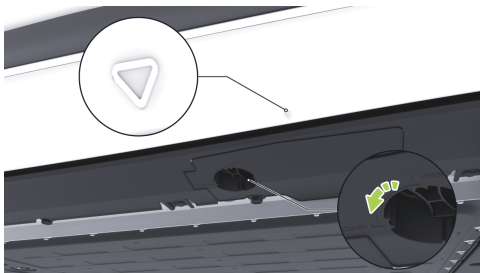

The position of the vehicle lifting point is confirmed by the arrows in the lower door trim. The trim panel is mounted under the lifting points and can be removed by turning the knob on the trim counter-clockwise. Remove the trim from the lifting points before lifting the vehicle using a jack.

1. Before lifting the vehicle with a jack:
 - The cleanliness of the jack needs to be checked and if dirt is present, wipe clean.
 - Place on a flat, firm surface, such as a soft surface, with backing plates.
 - The jack shall be used strictly in accordance with the rated capacity of the jack and shall not exceed the mark on the piston at any one lift, or, without the mark, at any one lift above 3/4 of the total screw thread lock or piston height. To prevent damage to the jack by lifting the screw or piston all the way up.
2. Using the jack to lift the position instructions:

Emergency Rescue



- When lifting, select the lifting point of the vehicle to prevent deformation or damage to the application point after jacking.

3. When lifting the vehicle using a jack:

- When lifting, first lift the vehicle slightly and then pause, check the jack, the ground, Good condition of shims, components, etc., such as poor jacking and gasket instability found, must be handled before continuing work.

If the vehicle is equipped with air suspension, before using the jack to lift the vehicle, **“Suspension Maintenance Mode”** must be turned on in the central control screen in the next step. When the vehicle is lowered to the ground, **“Suspension Maintenance Mode”** must be turned off in the next step.

warning

- It is recommended that the lifting operation be performed by professionals approved by the Xpeng Service Center. The vehicle has a power battery installed at the bottom. Lifting

by non-professionals may damage the high-voltage system of the vehicle, and the vehicle may also slide accidentally. Xpeng Motors does not assume any responsibility for direct or indirect losses caused by improper self-lifting.

- The vehicle can only be lifted at the specified lifting points under the vehicle.
- Please make sure to use the jack for lifting on a flat and solid road.
- Do not enter under the vehicle when using the jack to lift the vehicle, otherwise personal injury or death may occur.
- It is prohibited to lift the vehicle when there are passengers in the vehicle.



Temporary Tire Repair

Temporary tire repair

The vehicle is not equipped with a spare tire, an inflatable tire repair emergency kit is included with the vehicle.

The inflatable tire repair emergency kit consists of an inflator and a can of tire repair glue (for repairing a tire). When the tire is filled, the tire repair glue will penetrate small perforations up to 6mm in size and act as a temporary repair.



warning

- For punctures larger than 6 mm, severe tread damage, sidewall damage, tire tearing, or tire falling off the wheel hub, please contact the Xpeng Service Center.
- The tire repair emergency kit is only for a single temporary tire repair. The damaged



tire must be repaired or replaced as soon as possible.

- If a tire is temporarily repaired with tire repair glue, the driving speed must not exceed 80 km/h.
- Please read and follow all warnings and tips on the tire repair emergency kit.
- If you find that your car tire is flat, it is strictly forbidden to continue driving, otherwise it may cause serious injuries.

Tread glue

The tire repair glue supplied in the inflatable tire repair emergency kit is intended for use on Xpeng vehicles and does not damage the tire pressure sensors. Therefore, only the same type and volume of tire repair glue can be substituted. Tyre-topping glue can be purchased at the Xpeng Automobile Service Center.

The expiry date of the product is printed on the tire repair glue. If the validity period has expired,

the tire repair glue may lose its intended effect. Always purchase a new tire repair glue.

warning

- Do not use tire glue purchased from other channels, otherwise it may cause the tire pressure sensor to malfunction.
- Be sure to read and follow the safety and operating instructions of the tire glue.
- Keep the tire glue out of the reach of children.
- If the tire glue comes into contact with your eyes, rinse them immediately with clean water and seek medical attention.
- If you accidentally ingest the tire glue, seek medical attention immediately.
- If you accidentally inhale the tire glue, breathe fresh air immediately to avoid respiratory problems and seek medical attention immediately.



Taper inflation

Take the following steps to temporarily repair a small area of tire pores (less than 6mm):

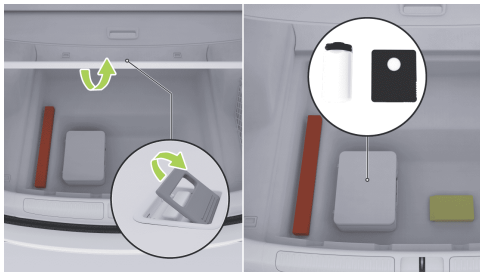

1. Remove the inflatable patch emergency kit from the loadspace.
2. Remove the inflation pump and tire repair glue from the tire repair emergency kit.



3. Remove the tire repair glue and shake evenly.



4. Screw one end of the tire repair glue joint into the tire valve and tighten. Be careful not to turn the tire repair glue pot upside down.



5. Connect and tighten the additional tire repair glue pipe to the charge pump and connect the charge pump power cable to a 12V power supply in the vehicle storage box.



Emergency Rescue

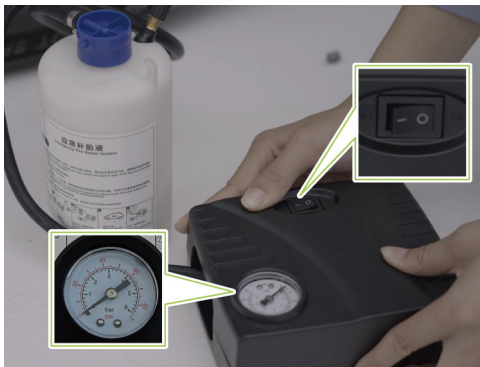

6. a. Press the switch to turn on and the inflation pump will begin to inflate the tires.
- b. During the filling process, the pressure gauge shows a pressure of about 300~600kPa.
- c. Observe the gauge until the tire pressure reaches the standard pressure and stops.

- d. Tire size Standard tire pressure values, refer to tire pressure label.
 - e. Check the tire pressures, if the tire set pressure cannot be reached within 20 minutes, it is considered to be unable to make up the tire.
7. Switch off the inflation pump and disconnect the connecting pipe from the tire valve. Wipe off excess tire glue from tire valve and hub. Then disconnect the connecting pipe from the pump and store the inflatable tire repair emergency tool back into the loadspace.
 8. Drive 5km or 10min immediately, so that the tire repair glue is distributed around the entire tire, the driving speed remains at 20 ~ 60km/h.
 9. Stop the vehicle and check the tire pressures.

caution

If the tire pressure is lower than 130kPa, it means that the tire damage cannot be repaired using tire sealant. Please park the

Emergency Rescue



vehicle safely on the roadside and contact the Xpeng Service Center.

10. Inflate to standard tire pressures.
11. Store the pump back into the loadspace.
12. Drive the vehicle at 20~80km/h to Xpeng Automobile Service Center for tire repair.

caution

- Please repair or replace the tire as soon as possible.
- After using the tire glue, you should buy a new tire glue in time.
- Please do not exceed 80km/h.

Inflate only

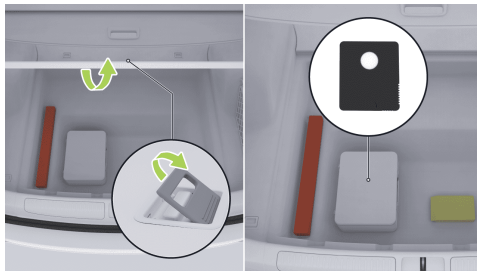

1. Remove the inflatable patch emergency kit from the loadspace.
2. Remove the inflation pump from the inflatable tubular recovery kit.



Emergency Rescue



3. Remove the connecting tube and the power cord from each side of the pump.
4. Install the inflation pump connecting pipe to the tire valve and tighten.
5. Connect the charge pump power cable to the vehicle's 12V power supply.



6. Press the switch to turn on and the inflation pump will begin to inflate the tires.
 - Observe the gauge until the tire pressure reaches the standard pressure and stops.
 - Tire size Standard tire pressure values, refer to tire pressure label.
7. Switch off the pump.



caution

- Please inflate to the standard tire pressure value, otherwise the tire pressure is too high or too low, which will easily accelerate tire wear.
- If the tire pressure is too high, you can reduce the tire pressure value by deflation.
 - Operation steps: unplug the inflation tube, press the metal rod in the center of the valve to deflate, and connect the inflation tube to read the pressure gauge value during the period until the tire pressure is reduced to the standard tire pressure.
- After adjusting the tire pressure, if the tire pressure monitoring system indicator light is

not off, please drive at a speed of 40km/h for a short time and pay attention to the recovery of the indicator light.

- After the vehicle has been driven for a period of time, as the tire temperature rises, the tire pressure will also rise slightly, which is a normal physical phenomenon.
- If the indicator light is still on, please contact the Xpeng Motors Service Center for processing.

Rescue Protection

Introduction

The vehicle power system is powered by a power battery, which can produce a high voltage electrical leak in the event of a serious collision, so when carrying out vehicle rescue operations should be operated by a professional rescue personnel and wear appropriate protective equipment to ensure personal safety.



warning

When operating the vehicle, please ensure that you are not carrying any metal items (such as necklaces, watches, etc.) to avoid electric shock injuries.

Electrical protection

Wear the following protective devices to avoid high voltage electrical shock injury:

- Rubber insulated gloves (insulated above 500V).
- Safety goggles.
- Insulated rubber shoes.
- Tools with insulated protective sleeves.

Chemical protection

If the power battery leaks electrolyte, wear the following protective devices to prevent skin, face, etc. injury:

- Face shield.
- Solvent insulating gloves.



Collision Protection

Introduction

The vehicle has a function to cut off the high pressure and high pressure bleeding. If the trigger condition is met in the event of a vehicle collision, the vehicle automatically cuts off the high voltage and simultaneously sounds, Various forms, such as text, remind the occupants to leave the vehicle as soon as possible to avoid hazards to the occupants.

Jump start

Operation

When the low voltage battery charge is low, the power battery automatically charges the low voltage battery. However, if the power battery is low, to avoid damage from excessive power battery discharge, the low voltage battery charging will be stopped. The commencement of operation of the locking anti-theft system will continuously drain the low voltage battery

power and failure to charge the vehicle in a timely manner may result in the vehicle not being unlocked or started due to the low voltage battery becoming discharged.

If the vehicle fails to start due to a low voltage battery failure, the vehicle can be started from an external 12V DC power source.



1. Open the front compartment and remove the front compartment access cover.



Emergency Rescue

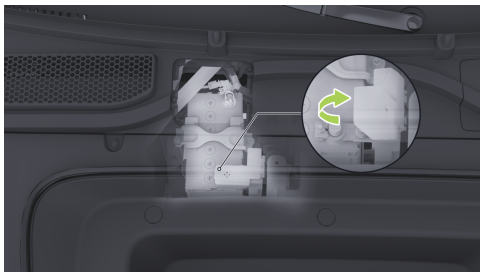

2. Open the trim cover on the 12V battery positive post.

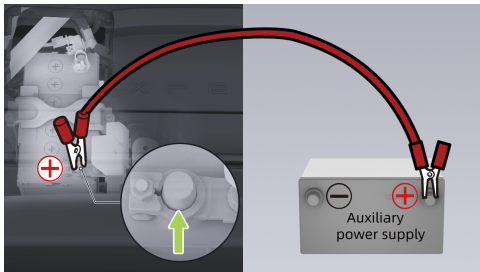

3. Connect one end of the red cable to the positive (+) of the vehicle 12V battery and the other end to the positive (+) of the auxiliary power supply.

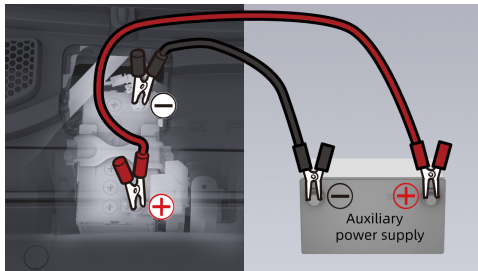

4. Connect one end of the black cable to the negative (-) of the vehicle 12V battery and the other end to the negative (-) of the auxiliary power supply.
5. If the instrument or the large screen is illuminated when the auxiliary power supply is connected, the emergency off switch must be pressed first or the vehicle will not start.



After power down, make sure the key fob or NFC card key is in the vehicle or the mobile key is connected to the vehicle, then press the brake pedal and engage to complete the start.

caution

The emergency auxiliary power supply cannot maintain high-power output for a long time. Generally, the auxiliary power supply must be connected and restarted within 30 seconds, otherwise the power must be reconnected.

6. Start the vehicle and when the vehicle has successfully started remove the attached cables in reverse order and replace the access cover.

warning

- Improper use of the connecting cable may cause the battery to explode, resulting in personal injury.

- The auxiliary power supply voltage must be the same as the voltage and capacity of the vehicle's battery, otherwise it may cause an explosion.
- The battery is prohibited from contacting open flames or static electricity, otherwise the flammable gas generated by the battery may be ignited by sparks, causing an explosion.
- Do not touch high-voltage components during operation to prevent high-voltage electric shock.

E-call*

Introduction

E-call is a vehicle intelligent emergency call system that can automatically or manually call a call for help in the event of an accident or emergency, providing information such as location of the vehicle and passenger injuries, so that rescue personnel can reach the scene in a timely manner. Rescue of people in distress.



Operation

In the event of an emergency, you can call for assistance in the following ways:



- **Manual Call:** Press and hold the SOS switch for more than 3 seconds and the system calls for assistance. To cancel a call while waiting to be turned on, press the switch again.
- **Automatic Call:** The system automatically calls for assistance in the event of a vehicle collision that triggers the deployment of an airbag.

- **Call Callback:** The system supports callback for a certain amount of time after a call is not connected or disconnected.

i Tips

- When the rescue call is waiting or connected, the SOS switch indicator lights up green. When the system fails, the SOS switch indicator lights up red, and you should get help in other ways.
- After the rescue call is connected, only the rescuer can end the call.
- The rescue call cannot continue to provide service after the validity period expires. Please pay attention to the validity period of the rescue call on the central control screen in time.
- In the case of battery failure, the rescue call can continue to support calls for a period of time.

Vehicle Information



Vehicle Parameters

Dimension parameters

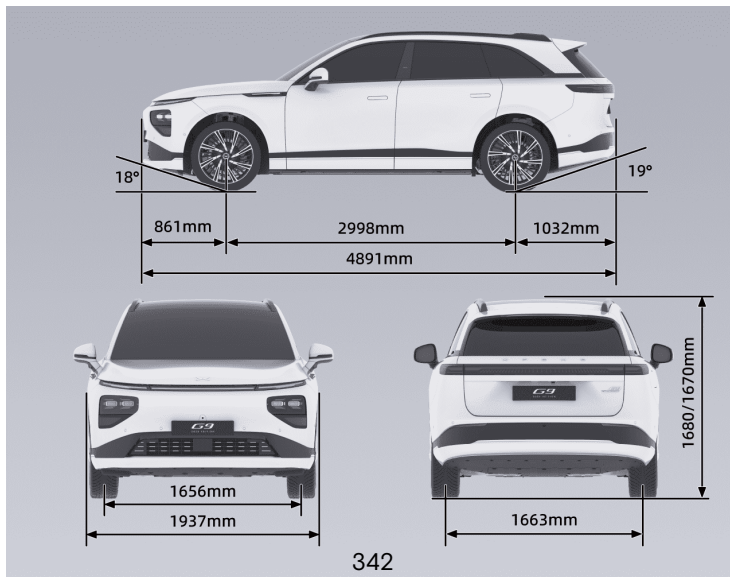



Vehicle Information

Overall dimensions	Length (mm)	4891
	Width (mm)	1937
	Height (mm)	1670/1680
Track width	Front track width (mm)	1656
	Rear track (mm)	1663
Wheelbase (mm)		2998
Front suspension (mm)		861
Rear suspension (mm)		1032
Number of passengers (persons)		5
Approach angle (full load) (°)		18
Departure angle (full load) (°)		19



i Tips

The exterior rearview mirrors (one on each side) are not included in the exterior width dimension. The allowable tolerance range of the vehicle dimension parameters is $\pm 1\%$.



Quality parameters

Project Name		Standard range 2WD	Long-range 2WD	Long-range 4WD
Overall curb mass (kg)		2210, 2235 (tow hook)	2290, 2315 (tow hook)	2395, 2420 (Tow Hooks)
Preparation	Front axle (kg)	980, 975 (tow hook)	1035, 1030 (tow hook)	1130, 1125 (tow hook)
	Rear axle (kg)	1230, 1260 (tow hook)	1255, 1285 (tow hook)	1265, 1295 (tow hook)
Maximum total mass (kg)		2730	2810	2910
Maximum	Front axle (kg)	1135	1195	1290
	Rear axle (kg)	1595	1615	1620

i Tips

The tolerance range of mass parameters is $\pm 3\%$, except for the maximum total mass.

Vehicle Information



Performance parameters

Minimum Turning Diameter (m)	11.8
Maximum vehicle speed (km/h)	200



Wheels and tires

Tires		255/50 R20	255/45 R21
Rim		20×8J	21×8.5J
Pressure (kPa)	Front Wheels (Empty Half/Loaded)	270/270	270/310
	Rear wheels (empty half load/full load)	270/270	270/310
Wheel balancing (after placing the balance blocks)	Inside Front Wheels (g)	≤ 8	
	Outside Front Wheels (g)	≤ 8	
	Inside Rear Wheel (g)	≤ 8	
	Outside Rear Wheel (g)	≤ 8	



Braking and suspension

Type	Foot-brake, X-type dual circuit hydraulic braking, acting on all wheels
Power Assisted	Electric power assistance
Free or empty brake pedal travel (mm)	≤ 2
Front wheel brake disc wear limit (without disc backing) (mm)	2
Rear brake disc wear limit (without disc backing) (mm)	2
Front Disc Wear Limit (mm)	30
Rear Disc Wear Limit (mm)	22



Vehicle Information

Front suspension type	Front double wishbone independent suspension
Rear suspension type	Rear five link independent suspension

Vehicle Information



Four-wheel positioning parameters

Project Name	Coil_Spring	Air Spring
Single-sided front wheel toe-in	$3' \pm 6'$	$0' \pm 6'$
Single side front camber	$-0.45^\circ \pm 0.5^\circ$	$-0.6^\circ \pm 0.5^\circ$
Castor angle of single-sided king pin	$5.6^\circ \pm 1.4^\circ$	$5.9^\circ \pm 1.4^\circ$
Single-sided king pin inclination angle	$7.9^\circ \pm 1^\circ$	$8.1^\circ \pm 1^\circ$
Single-sided rear wheel toe-in	$5' \pm 6'$	$8' \pm 6'$
Rear camber angle	$-1.0^\circ \pm 0.5^\circ$	$-1.4^\circ \pm 0.5^\circ$



Electric drive system parameters

Project Name		Rear electric drive system	Front Electric Drive System *
Drive motor	Type	Permanent magnet synchronization	AC Asynchronous
	Continuous power (kW)	110	50
	Continuous torque (N·m)	170	50
	Rated Speed (rpm)	6190	9550
	Maximum power (kW)	258	165
	Maximum torque (N·m)	465	230
	Maximum speed (rpm)	18000	20000



Seat adjustment parameters

In the home position, the seat adjustment parameters are as follows:

Seat type	Project	Parameter
Host drive seat	Adjust fore and aft	Total stroke 260mm, 212mm forward, 48mm backward
	Backrest adjustment	Total stroke 95°, Forward 20°, Backward 75°
	Seat cushion adjustment	Total stroke 10°, Up 10°, Down 0°
	Adjust up or down	Total stroke 65mm, 32.5mm up and 32.5mm down
Operator seat	Adjust fore and aft	Total stroke 260mm, 212mm forward, 48mm backward
	Backrest adjustment	Total stroke 95°, Forward 20°, Backward 75°
	Adjust up or down	Total stroke 65mm, 32.5mm up and 32.5mm down



Fluids and Capacities

Introduction

Project Name	Model number	Fill quantity
Front Electric Drive Lubricant * (L)	FUCHS Fox 4101	1.65
Rear Electric Drive Lubricant (L)		1.58
Coolant (L)	A mixture of glycol and water	Fill to near MAX line (approx. 16)
Air conditioning refrigerant (g)	R134a*/R1234yf*	1250 ± 15
Brake fluid (L)	DOT4	Fill to near MAX line (approx. 1.03)
Windshield Washer Fluid (L)	/	3.5



Nameplate and Label

Vehicle identification number



The vehicle identification number is stamped under the passenger seat.

Other vehicle identification numbers are located in the following locations:

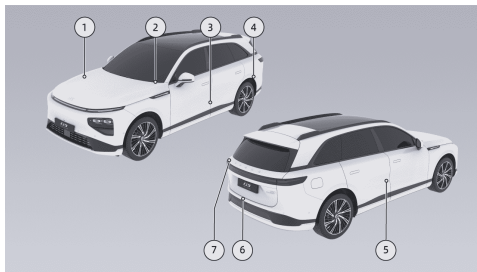

1. Affix to inside of front compartment cover.
2. Affix to the lower left of the front window glass.
3. Stick to the left B-pillar.
4. Affix to rear left wheelhouse.
5. Affixed to the rear right door inner panel.
6. Affix to rear quarter panel upper crossmember.
7. Affix to the left side of the boot door.



OBD diagnostic interface



The OBD interface for reading the electronic VIN code is located on the lower left of the instrument panel and data such as the electronic VIN code and vehicle status information can be read via the factory diagnostic tool or the factory official approved diagnostic equipment.

Complete vehicle product identification plate

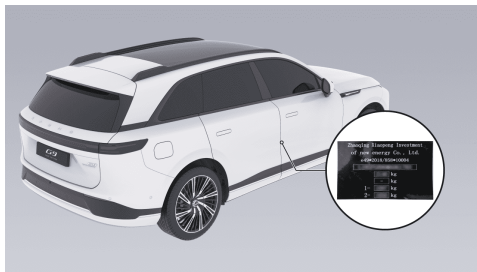

The product nameplate is located on the right B pillar and can be viewed when the right-hand door is opened.

Vehicle Information



Drive motor model and code

Front drive motor *

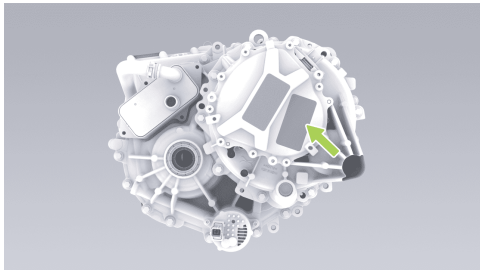

The drive motor type and coding are shown on the drive motor housing and drive motor label.

Rear drive motor

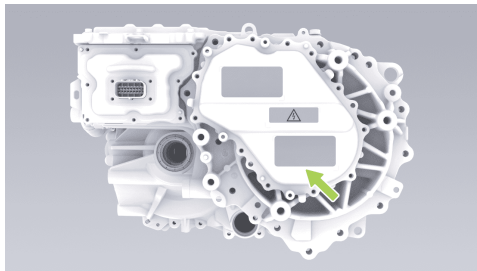

The drive motor type and coding are shown on the drive motor housing and drive motor label.



Parts and Modifications

Introduction

Use only genuine or approved parts from Xpeng MOTORS. Xpeng Motors rigorously tests the components to ensure their suitability, safety and reliability. These parts can only be purchased at Xpeng Automobile Service Center, installed by Xpeng Automobile professionals, and can be modified according to the advice of Xpeng Automobile experts.

Do not modify the vehicle with parts other than those originally approved by Xpeng, as this may affect vehicle operation, safety and durability and may violate local government regulations.

Avoid ultrasonic radars when making modifications to the body (e.g., fitting of a body color film, transparent bodywork, anti-crush strips, etc.). Millimeter wave radar, proximity camera, high awareness camera, etc., otherwise the normal use of related functions such as driving assistance will be affected.

The millimeter radar is located in the front and rear bumpers, and it is prohibited to paint the front and rear bumpers, to add a cover, etc., otherwise it will affect the normal use of the related functions such as driving assistance.

Private replacement, modification, or installation of radar or camera is prohibited. Otherwise, it will affect the normal use of driving aids and other related functions, there will also be radio interference, resulting in direct or indirect damage, Xpeng car does not assume any responsibility. If the radar or camera is defective, go to Xpeng Automobile Service Center for repair.

Do not modify the vehicle's suspension, braking, etc., which may adversely affect vehicle handling and safety.

Do not modify the vehicle fuse box as this may adversely affect the vehicle electrical system.

Changes to electronic components and software, wiring can affect the correct operation of functions and associated components, especially

Vehicle Information



safety related systems, and therefore the operation of the vehicle. Increase the risk of accident or injury.

Therefore, do not modify the wiring, electronic components and their software.

In addition, vehicle damage and performance issues arising from replacement, installation, modification using parts other than those originally manufactured or approved by Xpeng Motors, are not covered by the warranty, as a result of direct or indirect damage, Xpeng Motor will not be liable.

Power battery recycling requirements and procedures

Introduction

When replacing or disposing of a power battery, always contact the Xpeng Automobile Service Center for recycling. Disposing of the power battery at will contaminate the environment or

cause a safety accident, and the owner is responsible.

Window Radio waves

Introduction



The radiowave window is located on the windshield, keep the front windshield clean to ensure optimum results and minimize interference with the driving field of view.



 **warning**

- The radio wave window position must not be blocked.
- When affixing the necessary markings required by traffic regulations, the position around the radio wave window should be selected.