



Thank you for selecting JELD-WEN products. Attached are JELD-WEN's recommended installation instructions for Custom Lift and Slide doors. Read these instructions thoroughly before beginning. They are designed to work in most existing applications, however; existing conditions may require use of alternative methods to these instructions. If changes are needed, they are made at the installer's risk. For installations other than indicated in these instructions, contact a building professional. To adequately protect your door, please refer to "Appropriate Protection for Exterior Doors" for information on protection requirements at www.jeld-wen.com.

Newer construction methods have led to an increase in air and water tightness in buildings. This frequently leads to negative air pressure inside the house, which can draw water through very small openings. Our installation method integrates the door to the weather barrier of the structure (typically building wrap) and uses a sill pan to capture and drain incidental storm water from under the door to the exterior.

IMPORTANT INFORMATION AND GLOSSARY

Not all exterior door types may be installed into every wall condition in all areas. See our Appropriate Protection document for overhang requirements at www.jeld-wen.com. Consult your local building code official (or Authority having Jurisdiction) for applicable building codes and regulations. Local building code requirements supersede recommended installation instructions.

Please Note! Any door installation such that the sill is higher than 35 feet above ground level or into a wall condition not specifically addressed in these instructions must be designed by an architect or structural engineer. We recommend that all non pre-finished wood or fiberglass components be finished with an appropriate paint or stain prior to installation. See our Finishing document for details at www.jeld-wen.com. Failure to properly finish or install square, level and plumb and on a flat surface (without peak and valleys) could result in denial of warranty claims for operational or performance problems.

Note to Installer: Provide a copy of these instructions to the building owner. By installing this product, you acknowledge the terms and conditions of the limited warranty as part of the terms of the sale.

GLOSSARY

Astragal

The vertical trim attached to one of the panels of a sliding patio door that bridges the gap between the panels when closed and provides weather protection.

Backer Rod (backing material)

A material (e.g. foam rod) placed into a joint primarily to control the depth of the sealant.

Buck

A wood framework attached to the masonry inside a window or a door rough opening.

Continuous Air Seal

Backer rod and sealant or low expansion foam applied to the interior gap between the product and the building in a continuous fashion used to block air flow between the interior and exterior of the building envelope.

Interlock

A weatherstrip component that runs vertically along the stiles of either horizontal sliding sashes or sliding patio door panels. When the window/door is closed, the interlocks engage, locking together, to create a weather barrier.

Pilot Hole

A drilled hole that is no larger than the body of the screw (minus the threads).

Rough Opening

The framed opening in a wall where a door is to be installed.

Shiplap

The layering method in which each layer overlaps the layer below it so that water runs down the outside.

Sill Pan

A flashing component installed in the sill of the rough opening underneath the door. Sill pans have upturned walls along the interior edge and at both ends, creating a three sided box. This component serves as a collection device to drain incidental water to the exterior of the building and should be properly sealed to the opening. The best sill pan design has a positive slope to the exterior and offers continuous support to the door's sill.

Please allow sufficient time to properly prepare the rough opening, install the door, and ensure its proper operation.

Estimated Install Time for New Construction	<input type="checkbox"/> First Time: 6 hr.	
	<input type="checkbox"/> Experienced: 5 hr.	
	<input type="checkbox"/> Professional: 4 hr.	

LANDINGS

These instructions cover two door sill conditions: the **step-down landing** and the **continuous slab landing**. The installation methods vary slightly between landing types.

Step-Down Landing

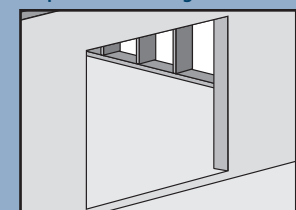

Continuous Slab Landing

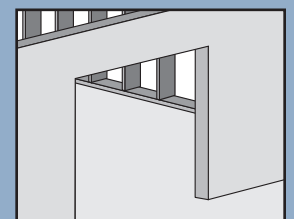

ROUGH OPENINGS

This installation guide specifically addresses masonry/block wall, sheathed wall and open-stud construction.

MASONRY/BLOCK WALL CONSTRUCTION

This installation assumes that a framework of 2x studs (often called a buck) has already been properly fastened and sealed to the concrete/masonry wall by a building professional.

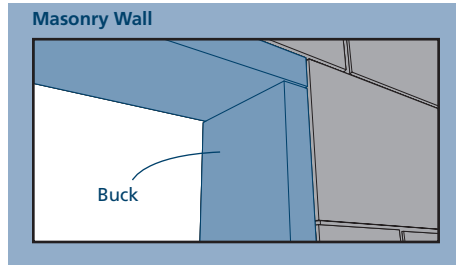

FULLY SHEATHED WALL CONSTRUCTION

The wall framing is covered by sheathing and the door will be mounted inside of the rough opening. This installation assumes building wrap is properly installed prior to installation.

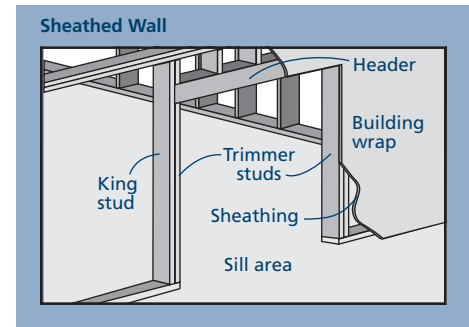

SAFETY AND HANDLING

SAFETY

- Read and fully understand ALL manufacturers' instructions before beginning. Failure to follow proper installation and finishing instructions may result in the denial of warranty claims for operational or performance problems.
- Do not work alone. Two or more people are required. Use safe lifting techniques.
- Use caution when handling glass. Broken or cracked glass can cause serious injury.
- Wear protective gear (e.g. safety glasses, gloves, ear protection, etc.).
- Operate hand/power tools safely and follow manufacturer's operating instructions.
- Use caution when working at elevated heights.
- If disturbing existing paint, take proper precautions if lead paint is suspected (commonly used before 1979). Your regional EPA (www.epa.gov/lead) or Consumer Product Safety Commission offices provide information regarding regulations and lead protection.

- **WARNING:** Drilling, sawing, sanding or machining wood products generates wood dust, a substance known to the State of California to cause cancer. Use a respirator or other safeguards to avoid inhaling wood dust.

MATERIALS AND DOOR HANDLING

- Heed material manufacturers' handling and application instructions.
- Protect adhesive surfaces from dirt, moisture, direct sunlight and folding over onto themselves.
- Handle in vertical position; do not drag on floor.
- Do not put stress on joints, corners or frames.
- Store door in dry, well-ventilated area in vertical, leaning position to allow air circulation; do not stack horizontally.
- Protect from exposure to direct sunlight during storage.
- Install only into vertical walls and when conditions and sheathing are dry.

IF INJURY OCCURS, IMMEDIATELY SEEK MEDICAL ATTENTION!

MATERIALS AND TOOLS

PARTS INCLUDED WITH PATIO DOOR

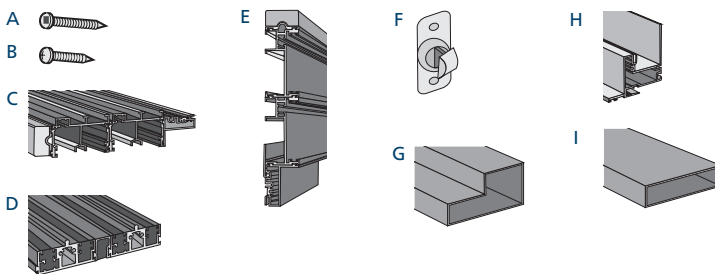

- A #8 x 1-1/4" square drive screws for frame assembly
- B #10 X 2-1/2" square drive screws for frame installation
- C Head frame
- D Sill track
- E Left and right side frame
- F Fixed panel keepers (if applicable)

For pocketing systems only:

- G Follower
- H Post interlock
- I Closure

Items not shown:

- Handle package
- Door panel(s)
- Astragal if applicable
- Corner seal pads
- Track caps

NEEDED MATERIALS

Note! JELD-WEN exterior window and door products should be installed in accordance with JELD-WEN's recommended installation and flashing directions, which are shipped with the products or can be found on our website: www.jeld-wen.com. Note that alternative installation methods and flashing systems may be utilized at the installer's or owner's discretion and, in such situations the installation should be done in accordance with the flashing manufacturer's instructions. Follow all material manufacturers' instructions for proper use and compatibility. When using flashing, spray adhesive/primer, sealant and foam products, we recommend using the same manufacturer and verifying compatibility. It is the End User's responsibility to determine if dissimilar materials are compatible to the substrates in the application.

- Sill: Wood Sub Floor: #8 x 1-1/4" corrosion-resistant, pan-head screws; Concrete Sub Floor: 1/4" diameter self-tapping concrete screws (Tapcon®, or equivalent); length of screw must penetrate at least 1-1/4" into the sub floor. Side Jamb: #10 x 2-1/2" corrosion-resistant, flat-head screws; Head jamb: #10 x 2-1/2" corrosion-resistant, pan-head screws.
- Non-compressible or non-water degradable shims.

MATERIALS AND TOOLS - CONTINUED

- Sill pan: It is best practice to use a pre-formed, rigid, positively sloped, PVC pan that provides continuous support. We recommend using SureSill™ Sloped Sill Pan™, manufactured by SureSill™, Ltd. An alternative would be a non-sloped pre-formed sill pan or one can be fabricated on site from metal or vinyl sheet material with the proper tools.
- 4", 6", or 9" (as required by local code and window configuration) wide self-adhered flashing: We recommend OSI® Butyl Flash Tape or equivalent.
- Spray adhesive/primer for self adhered flashing. Such as Loctite® 300 or equivalent.
- Sealant: We recommend OSI® QUAD® Max Sealant or equivalent. This can be used in any application and can be painted or ordered in a color matched product, if desired.
- Backer rod 1/8" larger than the widest portion of the gap (used in conjunction with sealant bead).
- Polyurethane low expansion Window and Door foam: We recommend OSI® QUAD® Foam or equivalent.

- Drip cap if required because of door location and exposure. Doors with an adequate overhang (see our Appropriate Protection document at www.jeld-wen.com) may not need a drip cap. In addition to sill pans, SureSill™ also offers types of head flashing.

For installations into a Buck:

- Liquid applied flashing (Protecto Wrap LWM 200 or equivalent)

NEEDED TOOLS

- Hacksaw (SureSill™ sill pan) or Cutting shears (fabricated sill pan)
- Tape measure
- Utility knife
- Level (6' recommended)
- J-roller
- Caulking gun
- Drill with bits
- Screwdrivers
- Hammer drill and masonry bits for masonry applications

1

REMOVE PACKAGING AND INSPECT DOOR

REMOVE PACKAGING

Remove shipping materials such as corner covers, shipping blocks or pads.

INSPECT DOOR

- Cosmetic damage
- Included parts (See Parts List above)

- Correct product (size, color, grid pattern, handing, glazing, energy-efficiency requirements, etc.)

If any of the above conditions represent a concern, or if you expect environmental conditions to exceed the door's performance rating, do not install the door. Contact your dealer or distributor for recommendations.

2

INSPECT ROUGH OPENING

- Verify the rough opening (inside the buck) is no larger than 1" wider and 1/2" taller than the patio door frame.
- Verify the rough opening is square. The (A) and (B) measurements should be the same. Maximum allowable deviation from square is 1/4".
- Verify the rough opening is plumb and level (C, E) and (D). The maximum allowable deviation is 1/16" for every 2' of rough opening (not to exceed 1/8").

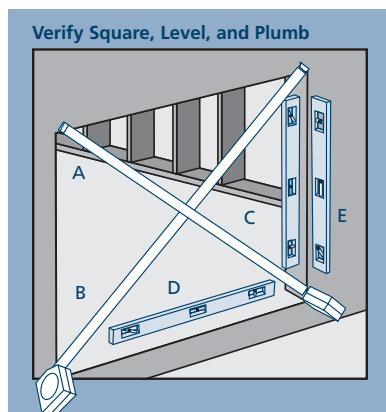

- The rough opening sill must not be crowned or sagged (D), but rather level or sloped (positive slope) to the exterior.
- The exterior face of the rough opening must be in a single plane (E) with less than 1/8" twist from corner to corner.
- In wood frame construction, the header must be supported by trimmer studs and designed to ensure that no load is transferred to patio door unit.
- Correct any deviations before installing the patio door. Consult a building professional as needed.
- Verify the rough opening is clean and dry.

FOR RETROFIT INSTALLATIONS

After removing the old door, remove sufficient cladding (siding, stucco, etc.) to expose enough intact building wrap to properly seal the door system to the opening. If damaged, apply new building wrap in shiplap manner. Verify the rough opening framing is structurally sound. Contact your local waste management entities for proper disposal or recycling of products being removed.

3 INSTALL SILL PAN

The sill can be prepared using one of two methods: We recommend SureSill™ Sloped Sill Pan™ available from SureSill at www.suresill.com, building supply stores, and some manufacturing locations or fabricate a sill pan on site. **Note! Sills wider than 7" will not allow a pre-formed sill pan to be used, follow the instructions for the job site fabricated sill pan instead.** If installing a SureSill sill pan, follow SureSill's instructions for installation and skip to section 4 "PREPARE BUCK", or to section 5, "PREPARE STUD-FRAMED WALL" as it applies to your situation. If fabricating a sill pan on the job site, follow the instructions below.

JOBSITE FABRICATED SILL PAN

1. Cut a piece of sheet material to the length shown.
2. Lightly crease folding lines 1/2" in from the two short sides and one long side.
3. Measure the width of the frame and add 9/16".
4. Take this distance from the back edge and lightly crease a folding line across the sheet material.
5. For step-down landings, cut 1/2" in at this line on both sides of the sheet material.
6. For continuous slab, cut across the folding line.

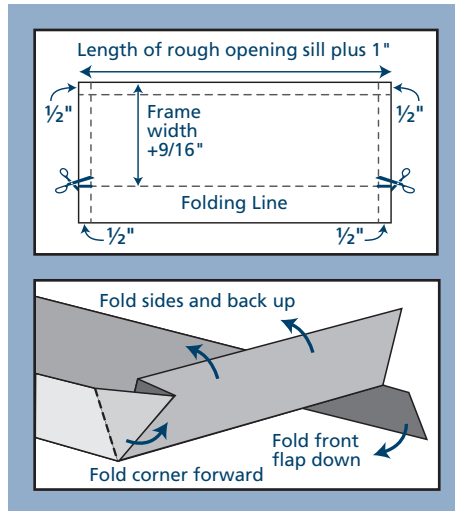

7. Fold the three back sides up to make a 3-sided box, and, for step-down landings, fold the front flap down.

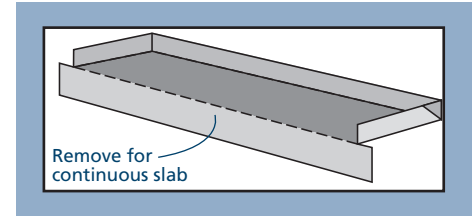

INSTALL SILL PAN

1. Set the sill pan in the rough opening, aligning the front edge (for continuous slab) or folded down edge (for step down) with the exterior of the rough opening.
2. Mark a line across the front and back of the sill pan.
3. Apply three 3/8" beads of sealant between the lines.
4. Place the sill pan in the rough opening. Firmly press the sill pan into the sealant with a J-roller.

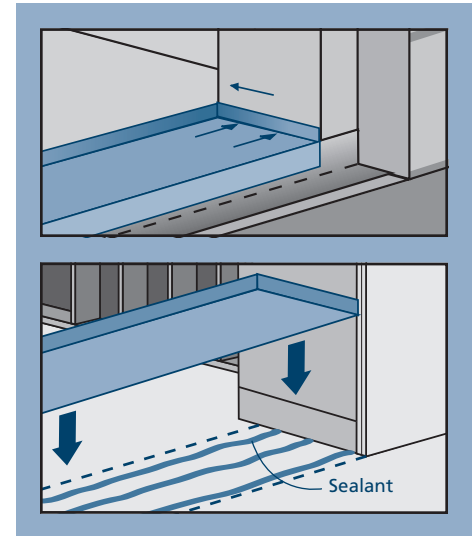

4 PREPARE BUCK

Note! This section applies to installations into a buck only. For installations into a stud-framed wall, begin with section 5, "PREPARE STUD-FRAMED WALL."

1. Seal any joint larger than 1/16" in the buck and between the buck and the concrete/masonry with sealant.
2. Cover the concrete/masonry at the head and jambs with liquid applied or self-adhered flashing as shown. If using self-adhered flashing, follow manufacturers' instructions for appropriate use of primers and other application methods.

END of Buck Instructions, SKIP to section 6, "INSTALL DOOR."

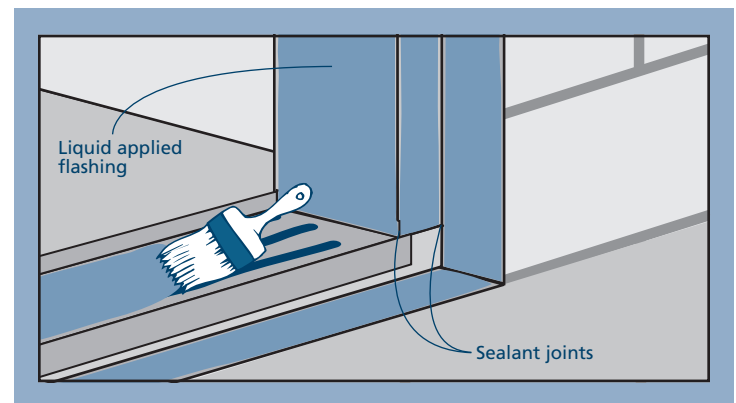

5

PREPARE STUD-FRAMED WALL

PREPARE BUILDING WRAP

Verify these steps are allowed by the building wrap manufacturer.

1. Trim the sides sufficiently to allow the nailing fin to be mounted against the sheathing.
2. If the door extends beyond the exterior plain of the building and a drip cap is desired, at the head, slit building wrap 6" at 45°. Tape up as shown. We recommend installing a drip cap because this integrates the building wrap and drip cap to protect the structure and the product from incidental water.

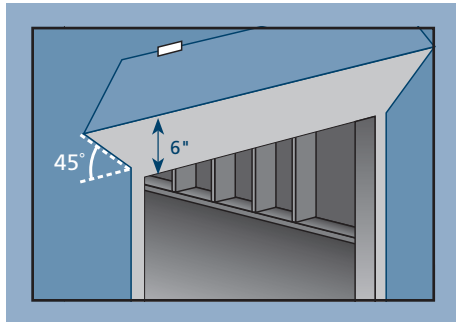

INSTALL JOBSITE FABRICATED SILL PAN

Note! The rest of the steps in this section only apply to a jobsite fabricated sill pan. If installing a sill pan that you have purchased, follow manufacturer's instructions for installation and skip to section 6, "INSTALL DOOR."

1. If installing a metal sill pan on concrete, cut a piece of self-adhered flashing the length of the sill pan and adhere it to the entire bottom surface where the pan will sit on the concrete.
2. Apply spray adhesive/primer to the sill pan and surrounding area. Follow manufacturer's instructions for application methods.

3. Cut a piece of self-adhered flashing the length of the sill and apply over the entire sill pan. For step down landings, fold flashing down as shown. For continuous slabs, trim flush with rough opening.
4. Cut two pieces of self-adhered flashing 9" wide by the sill pan width + 3" long.
 - a. For continuous slab landings only, cut out the inside corner.
 - b. Adhere the pieces of flashing to the inside corners. Stretch flashing as needed to cover corners and lay flat.
5. Smooth gaps or bubbles beneath self-adhered flashing with a J-roller (remove and replace if necessary).
6. Seal back corners of sill pan with sealant.

End of Stud-Framed Wall Instructions, continue with section 6, "INSTALL DOOR."

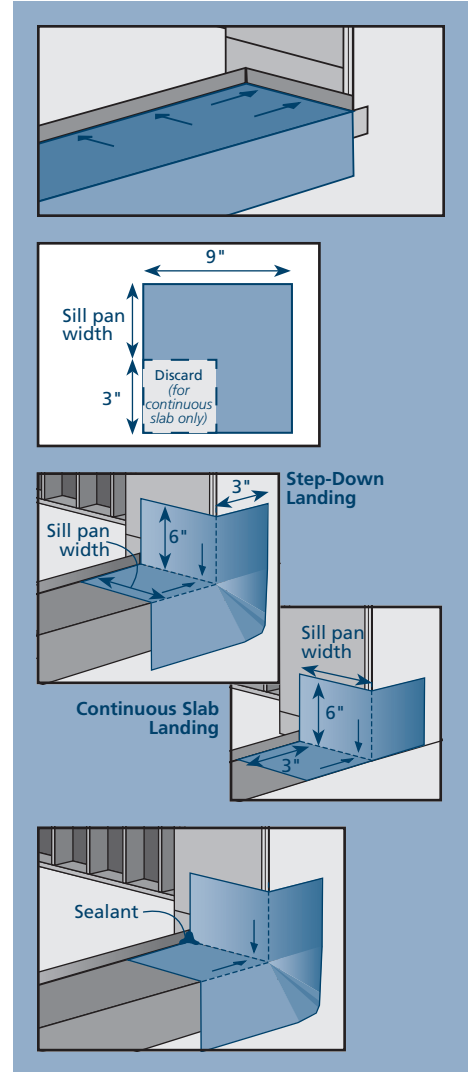

6

INSTALL DOOR

ASSEMBLE FRAME

1. On a clean and flat surface, lay out frame head, sill and side jambs with the exterior side up. If installing a pocketing system, there will be post interlock(s) for each end that pockets used instead of a side jamb piece. Post interlock(s) do not install on the extreme end of the head and sill tracks, but will install to the side where the pre drilled holes are located (approximately the width of one panel from the end of the head and sill tracks).
2. If gaskets are provided, adhere to both ends of the sill. Run a bead of silicone on all surfaces of the sill as shown. Repeat silicone application for the head where the ends will contact the jambs.
3. Clamp the frame corners as needed to ensure that the frame sections fit together flush and using the supplied 1-1/4" screws, fasten the sill to the right and left jamb frame parts. The pre-drilled holes in the jamb will line up with the screw bosses in the sill. Make sure the attached gasket lies flat and the screws are inserted properly into the screw bosses.
4. Using the supplied 1-1/4" screws, fasten the header to the right and left jamb frame parts through the pre-drilled holes in the jambs.
5. Seal the screw heads and the outside of each corner joint with sealant.

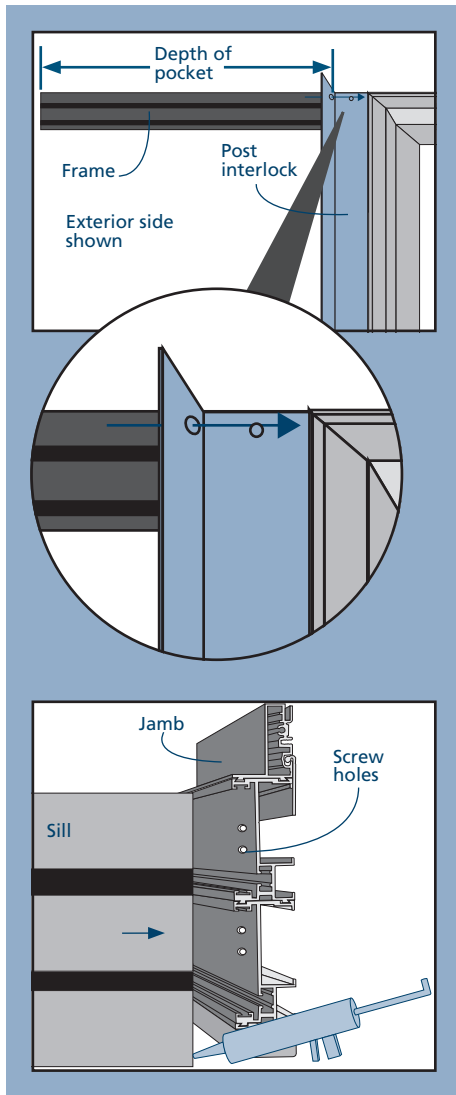

INSTALL FRAME

Warning! To avoid injury, use at least two people to install.

1. If installing a pre-formed sill pan, follow manufacturer's instructions and skip this step. If installing a job site fabricated sill pan, run a continuous 3/8" bead of sealant along the sill pan back dam. When the frame is installed, make sure the frame makes solid contact with the sealant. Add more sealant if necessary.
2. Tilt the frame into the rough opening. Adequately support the frame until fully installed.
3. Align the exterior of the frame, or applied nailing fin, with the most exterior surface of the structure (the exterior face of the concrete wall, framing or sheathing).

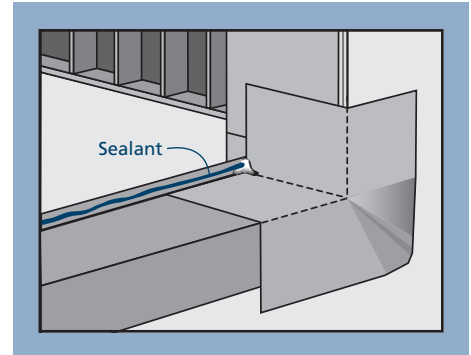

SHIM THE JAMBS

Note! Secure all shims with sealant.

1. From the interior, shim the side jambs at each pre-drilled hole. Shim head track next to pre-drilled holes. Also shim at the strike plate(s) if applicable so that strike plate screws (installed later) will each penetrate a shim.
2. Inspect the frame for square, level, and plumb (remove and reinstall if necessary).

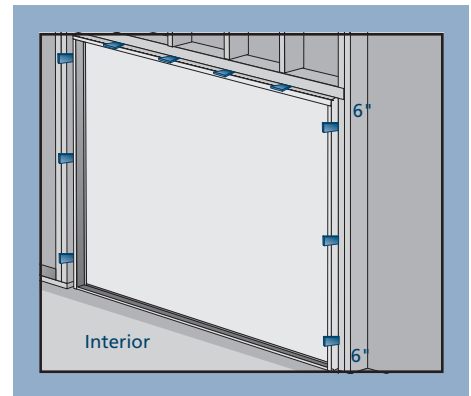

FASTEN FRAME

1. To secure the head, fasten through each pre-drilled hole using #10 x 2-1/2" screws. Fastener holes should not go through, but next to shims. Move shims accordingly to be next to fastener holes if necessary.
2. To secure the sill, put a generous amount of silicone sealant in each pre-drilled hole and drive a #10 x 2-1/2" screw through each hole.
3. Secure the side jambs through each pre-drilled hole.
6. Verify the unit is square by re-measuring on the diagonals.
7. Verify the unit is plumb and level.
8. Use a level (4 foot recommended) to ensure there are no bows in the framing.
9. Adjust screws and re-shim as needed to correct any bows.

6

INSTALL DOOR - CONTINUED

INSTALL PANELS

Note! To avoid damage to the rollers, clean all debris from the main roller track in the sill.

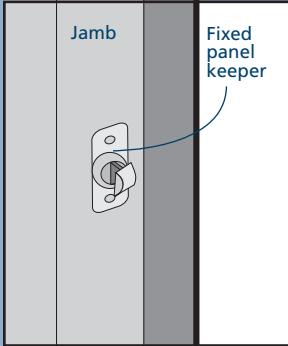
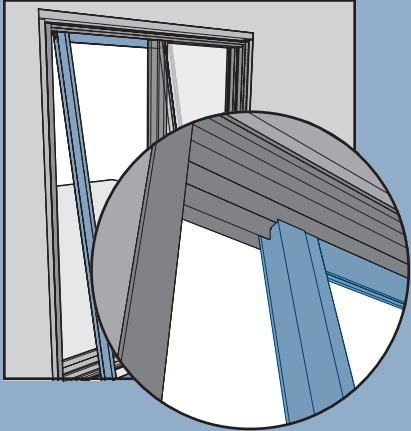
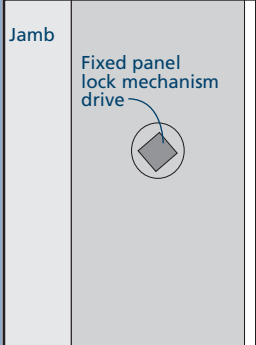
1. Study the overall door configuration before installation. Each panel will be labeled with a number indicating the order of installation into the frame and will contain an elevation drawing of the entire unit. Refer to these drawings and the sections below for detailed instructions on installing each panel into the frame. **Note!** Panels are **not reversible or interchangeable**. Two panel doors are shown, but also apply to three or more panels.
2. If installing a fixed panel, install keepers in the jamb by driving the provided #10 x 2-1/2 flat head, square drive screws (remove keepers and use #10 x 2-1/2 screws if pre-installed) through the keeper, pre-drilled holes in the frame and into the rough opening.
 
3. Working from the outside, align the panel marked number 1 next to the frame end with the interlock facing the interior. Place the top of the first panel into the exterior most head track directly over the corresponding sill location.
 
4. Raise the panel and swing the bottom in so the wheels are properly located on the sill track.
5. Push the panel fully into the pocket (for pocketing systems) or to the fixed panel jamb (for stacking systems).
 
6. If installing a fixed panel, use either a handle or 3/8" ratchet to rotate the locking mechanism 180 degrees to secure the fixed panel to the jamb.
7. Repeat for all remaining panels in sequential order.

FOLLOWER AND POCKET CLOSURE (POCKETING SYSTEMS ONLY)

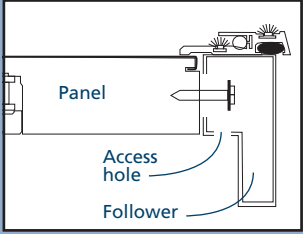
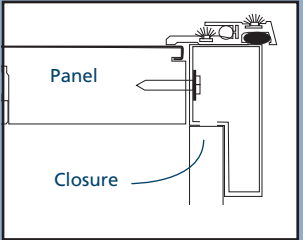
1. From interior side of system, slide the follower over the bolt heads located at the back edge of the last panel and align so that the weatherstrip is tight against the exterior surface of the panel. Tighten the bolts with a 1/2" wrench to secure the follower.
 
2. Attach the pocket closure to the follower using the screws supplied in the "Follower/Pocket Closure" screw package.
 

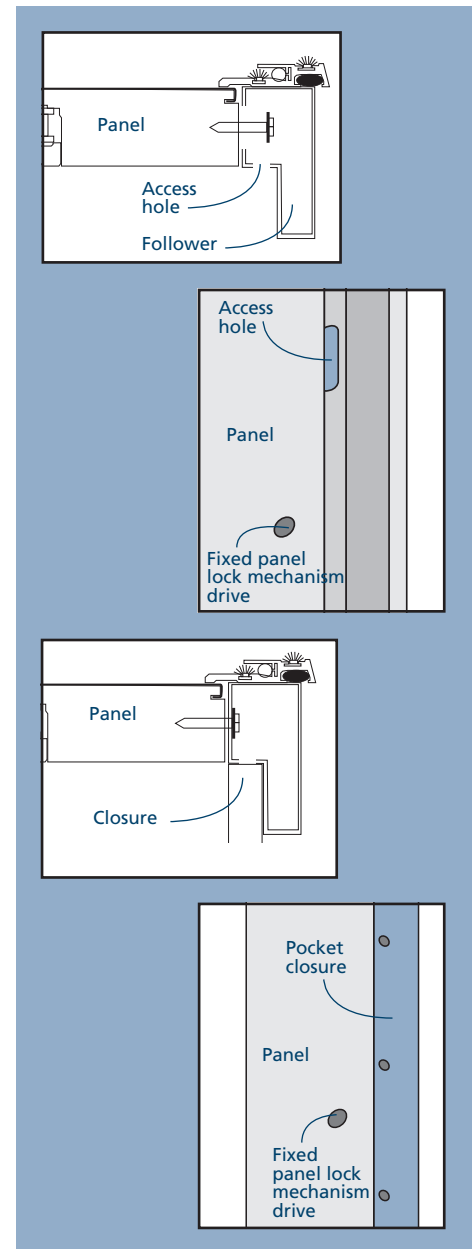

7

COMPLETE INSTALLATION

FINISH INSTALLATION

1. Refer to the manufacturer's instructions supplied in the handle package.
2. Install track covers.
3. Install astragal if applicable.
4. If the door unit has a strike jamb against a rough opening jamb, drive #10 x 2-1/2" screws through the screw holes in the strike plate. Replace existing screws if necessary. This will secure the door frame to the structure.
5. Install drip cap if required or desired. Fold the building wrap (previously taped up) down over the drip cap and seal the cut ends with self-adhered flashing or building wrap tape.

CONTINUOUS AIR SEAL

Create a continuous air seal on the interior between the rough opening and the door frame with backer rod and sealant or low expansion foam. Allow the foam to fully cure and cut flush with a sharp knife. Make sure the foam cuts cleanly and doesn't tear.

AFTER INSTALLATION

1. Install exterior wall (cladding) surface per manufactures' guidelines.
2. Leave an expansion/contraction gap of approximately 3/8" between window frame and final exterior wall surface (siding, stucco, etc.). For a finished look and additional protection, seal this gap on the sides with backer rod and sealant. If sealant is applied above the drip cap ensure the sealant bead is discontinuous to allow for drainage.
3. Protect recently installed units from damage from plaster, paint, etc. by covering the unit with plastic.
4. Remove labels or other materials adhered to glass within 30 days after installation.

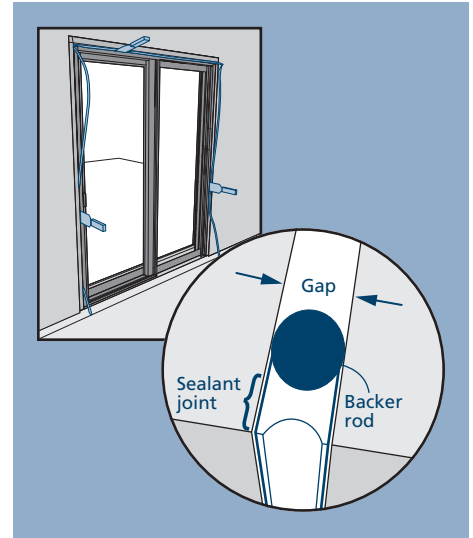

Please visit jeld-wen.com for warranty and care and maintenance information.

Thank you for choosing

