

## MATERIALS

Extruded vinyl profiles comply with the performance requirements of AAMA 303-97. Colour is White.

## FRAME

All frames are assembled utilizing fusion-welded technology for added strength and durability. Frame jamb depth is 3-1/4" (83mm), and the exterior wall thickness is 0.065 of an inch. Frames come standard with an accessory groove to accommodate exterior mouldings and with an open integrated 1/2-3/4" return. A closed version is also available for replacement purposes.

## SASH

Sash is 2-1/4" (nominal) or (54.61mm) thick, and is assembled utilizing fusion-welded technology for added strength and durability and is shadow groove cleaned.

## GLAZING

3/4" (19mm) insulating glass consists of two lites of glass sealed around a warm edge spacer. All insulating glass units comply with the performance requirements of the IGMAC in accordance with either CAN/CGSB-12.8-97.

## GLAZING OPTIONS

3/4" (19mm) insulated glass available in clear, Low-E with Argon, tinted, frosted, or other specialty insulating glass as specified. All glass is available tempered. Up to 7/8" insulating available as an option.

## WEATHER-STRIPPING

Pile weatherstrip applied along the full perimeter of operating sash. Double row of co-extruded weatherstrips meet AAMA 701 or AAMA 702. Weatherstrip along full perimeter of the frame.

## HARDWARE

Sash pivot on concealed hinges with sliding steel reinforced nylon shoes in an integral frame track. Steel concealed locking system is standard. Encore™ dual arm roto-operator has removable polycarbonate cover, die cast zinc bash and hardened steel worm gears and arms. Hinges and roto-operator arms feature E-Gard coating system. One locking lever is located on each side jamb.

## INTERIOR INSECT SCREENS

Charcoal fiberglass screen cloth (18" x 16" mesh) set in white painted roll formed aluminium frame fitted to the inside of the window. Insect screens are intended to allow air and light in and to keep insects out. They are not intended to keep anyone or anything from falling through an open window. For safety screens or other security devices contact your local building supply retailer.

## GRILLES

Removable, 5/8", all vinyl rectangular grilles.

Vinyl SDL (Simulated Divided Lite) - 7/8" (23mm), or 2" (58mm) vinyl false mullion permanently applied on both sides of the insulating glass, with or without spacer bar.

Internal Grilles (Grilles between the Glass) - Georgian, pencil bar, square or flat mounted between the glass panes suspended within the air cavity.

## INSTALLATION

Installation per JELD-WEN Installation Method for All Vinyl Windows. See [www.jeld-wen.com/resources](http://www.jeld-wen.com/resources) for instructions.

## PERFORMANCE

CSA-Certified - (rated and labeled in accordance with CSA) certification program  
NFRC Certified - (rated and labeled in accordance with NFRC)

Quick SPEC Guide

Specification	Standard features	Optional features Some options may require additional lead times. Consult your JELD-WEN Sales Representative.
Colour	White	Painted exterior - white interior A-06 Maize A-71 Dark Clay A-34 Savanna A-72 Canyon Clay A-42 Hickory A-74 Sandalwood A-43 Cashmere A-75 Wicker A-44 Mist Blue A-79 Tan A-51 Sumac CL-025 Clay A-53 Arcadian IV-050 Almond
Size	- Width: 20 3/4" to 50" - Height: 13 3/4" to 42"	• Any size with minimum and maximum parameters
Frame	• Exterior accessory groove • Open frame 1/2-3/4" return	
Exterior Trim	• Exterior accessory groove	#401 - Exterior finish trim #411 - 1" x 2" brickmould with nailing flange (no 'J' channel) #412 - 1" x 2" brickmould with 'J' channel and nailing flange #413 - 1" x 2" brickmould #414 - 1 5/16" extension with brickmould, 'J' channel and nailing flange (for 4 9/16" frame) #415 - 2 5/8" extension #422 - Brickmould and nailing flange (no 'J' channel) #423 - Brickmould, 'J' channel and nailing flange ( <b>integral</b> ) #426 - Brickmould #427 - 1 5/16" extension ( <b>integral</b> ) #428 - 1 5/16" exterior finish trim and nailing flange #569 - 1" x 3 1/2" brickmould with nailing flange (no 'J' channel) #570 - 1" x 3 1/2" brickmould with 'J' channel and nailing flange #571 - 1" x 3 1/2" brickmould finish trim #210 - Adaptor for sill expander (in 16 foot lengths only) not installed #211 - 3 3/4" sill expander (in 16 foot lengths only) not installed
Glazing	• Insulating Clear with warm edge spacer	- Low-E - Satin - Bronze - Grey - Frosted (pinhead Morocco) - Gluechip - Laminated - All glass available tempered
Hardware	• Rotogear operator • Folding handle	
Hardware Colour	• White	
Screens	• Fiberglass	

Quick SPEC Guide

Specification	Standard features	Optional features Some options may require additional lead times. Consult your JELD-WEN Sales Representative.																																				
Screen Frame Colour	<ul style="list-style-type: none"> <li>White</li> </ul>																																					
Grilles		<ul style="list-style-type: none"> <li>5/8" all vinyl removable grilles</li> <li>5/8" white internal Georgian (grilles between the glass)</li> <li>7/8" SDL (simulated divided lite) with or without spacer bar</li> <li>2" false mullion with or without spacer bar</li> </ul> <table border="0"> <tr> <td><b>Georgian</b></td> <td><b>Pencil Bar</b></td> </tr> <tr> <td>5/8" Light oak/White</td> <td>White</td> </tr> <tr> <td>5/8" Dark oak/White</td> <td>Brass</td> </tr> <tr> <td>5/8" Amber oak/White</td> <td>Grey</td> </tr> <tr> <td>5/8" Cherry/White</td> <td>Pewter</td> </tr> <tr> <td>5/8" Black/White</td> <td></td> </tr> <tr> <td>5/8" Ivory/White</td> <td><b>Square</b></td> </tr> <tr> <td>5/8" Wicker/White</td> <td>Black</td> </tr> <tr> <td>5/8" Sablon/White</td> <td>Pewter</td> </tr> <tr> <td>5/8" Clay</td> <td>White</td> </tr> <tr> <td>5/8" Clay/White</td> <td>Brass</td> </tr> <tr> <td>5/8" Brown/White</td> <td></td> </tr> <tr> <td>5/8" Commercial brown/White</td> <td><b>Flat</b></td> </tr> <tr> <td>5/8" Brass</td> <td>5/8" Ivory/White</td> </tr> <tr> <td>1" White</td> <td>5/8" White</td> </tr> <tr> <td></td> <td>5/8" Clay/White</td> </tr> <tr> <td></td> <td>5/8" Clay</td> </tr> <tr> <td></td> <td>1" White</td> </tr> </table>	<b>Georgian</b>	<b>Pencil Bar</b>	5/8" Light oak/White	White	5/8" Dark oak/White	Brass	5/8" Amber oak/White	Grey	5/8" Cherry/White	Pewter	5/8" Black/White		5/8" Ivory/White	<b>Square</b>	5/8" Wicker/White	Black	5/8" Sablon/White	Pewter	5/8" Clay	White	5/8" Clay/White	Brass	5/8" Brown/White		5/8" Commercial brown/White	<b>Flat</b>	5/8" Brass	5/8" Ivory/White	1" White	5/8" White		5/8" Clay/White		5/8" Clay		1" White
<b>Georgian</b>	<b>Pencil Bar</b>																																					
5/8" Light oak/White	White																																					
5/8" Dark oak/White	Brass																																					
5/8" Amber oak/White	Grey																																					
5/8" Cherry/White	Pewter																																					
5/8" Black/White																																						
5/8" Ivory/White	<b>Square</b>																																					
5/8" Wicker/White	Black																																					
5/8" Sablon/White	Pewter																																					
5/8" Clay	White																																					
5/8" Clay/White	Brass																																					
5/8" Brown/White																																						
5/8" Commercial brown/White	<b>Flat</b>																																					
5/8" Brass	5/8" Ivory/White																																					
1" White	5/8" White																																					
	5/8" Clay/White																																					
	5/8" Clay																																					
	1" White																																					
Jamb Depth	<ul style="list-style-type: none"> <li>3 1/4"</li> </ul>	<ul style="list-style-type: none"> <li>Closed interior frame</li> <li>Vinyl clad interior jamb extension up to 8 7/8"</li> <li>Natural interior jamb extension up to 4 3/4" clear or finger jointed pine</li> </ul>																																				

### General Information

#### MULTIPLE ASSEMBLIES

All vinyl awning windows may be mullied above, below, or beside other vinyl awning windows, or other vinyl window products. Factory assembled mulls are limited in height (99"), width (150"), and a total area (60 square feet).

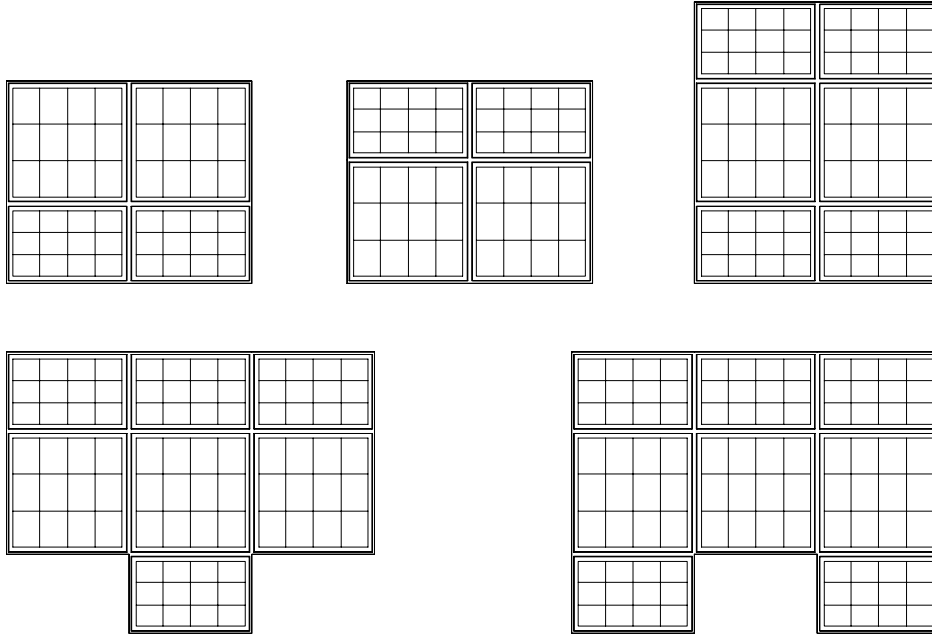

All vinyl

### EZ Spec Guide

ELEVATION DRAWINGS UTILIZE A LIMITED NUMBER OF PROJECTED LINES TO PRODUCE A RUDIMENTARY DRAWING INTENDED TO BE USED IN A SMALL GRAPHICAL SCALE. ELEVATIONS ARE VIEWED PERPENDICULAR FROM THE EXTERIOR OF THE STRUCTURE. IF MORE DIMENSIONS ARE NEEDED, USE THE SECTION DRAWINGS FOR MORE COMPLETE DEPICTIONS.

**Height:**  
 Rough Opening 42 3/4" - 1086mm  
 Frame Size 42" - 1067mm  
 Glass Size 35 5/8" - 905mm

**Width:**  
 Rough Opening 34 3/4" - 883mm  
 Frame Size 34" - 864mm  
 Glass Size 27 5/8" - 702mm

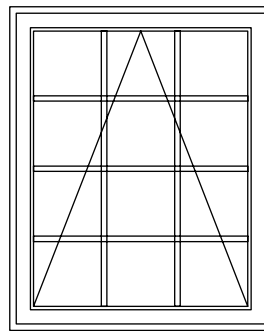

OUTSIDE OF FRAME

VL10T034042

BOOK CODE

- 'VL' INDICATES DF3113 VINYL AWNING SERIE
- THE FIRST DIGIT INDICATES THE NUMBER OF UNITS MULLED TOGETHER IN WIDTH
- 'T' INDICATES DUAL GLAZED PRODUCT
- THE NEXT THREE NUMBERS INDICATE THE UNIT HEIGHT IN INCHES
- THE FIRST THREE NUMBERS INDICATE THE UNIT WIDTH IN INCHES

#### GENERAL AWNING NOTES

1. VINYL AWNING UNITS ARE AVAILABLE AS OPERATING OR STATIONARY UNITS.
2. UNIT ELEVATIONS ARE SHOWN WITHOUT EXTERIOR TRIM.

#### AWNING PICTURE COMBINATIONS

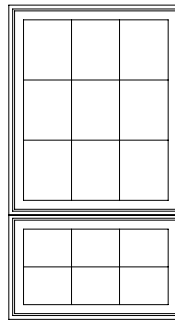

VL10BT042070

INDICATES A TOP FIXED SASH COMBINATION, UNLESS SPECIFIED, LOWER UNIT IS ALWAYS 23" IN HEIGHT

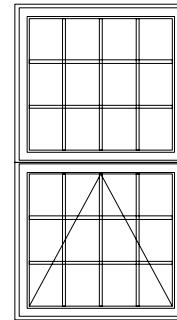

VL10CT038070

INDICATES A TOP FIXED SASH COMBINATION, SPLIT HALF/HALF

# Architectural Detail manual

## Awning window DF3113

All vinyl

Dim Col.  
CADRE  
FRAMME  
VERRE

23 3/4" • 602mm  
23 3/8" • 594mm  
16 5/8" • 422mm

31 3/4" • 806mm  
31 1/8" • 787mm  
24 5/8" • 625mm

39 3/4" • 1010mm  
39 1/8" • 991mm  
32 5/8" • 829mm

42 3/4" • 1086mm  
42 1/8" • 1067mm  
35 5/8" • 905mm

22 3/4" • 578mm  
22" • 559mm  
15 5/8" • 397mm

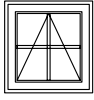

VL10T022023

26 3/4" • 679mm  
26" • 660mm  
19 5/8" • 498mm

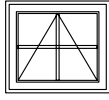

VL10T026023

30 3/4" • 781mm  
30" • 762mm  
23 5/8" • 600mm

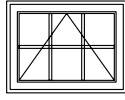

VL10T030023

34 3/4" • 883mm  
34" • 864mm  
27 5/8" • 702mm

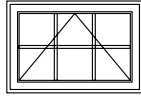

VL10T034023

36 3/4" • 934mm  
36" • 915mm  
29 5/8" • 752mm

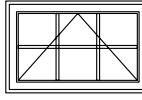

VL10T036023

38 3/4" • 984mm  
38" • 965mm  
31 5/8" • 803mm

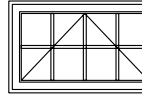

VL10T038023

42 3/4" • 1086mm  
42" • 1067mm  
35 5/8" • 905mm

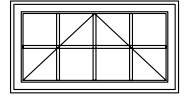

VL10T042023

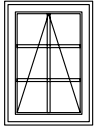

VL10T022031

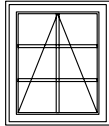

VL10T026031

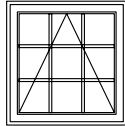

VL10T030031

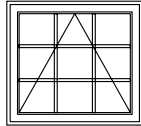

VL10T034031

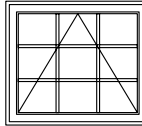

VL10T036031

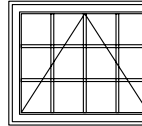

VL10T038031

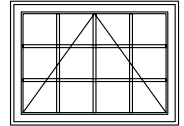

VL10T042031

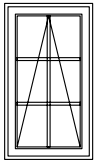

VL10T022039

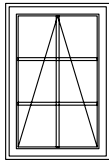

VL10T026039

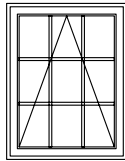

VL10T030039

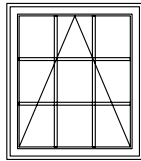

VL10T034039

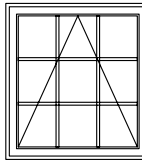

VL10T036039

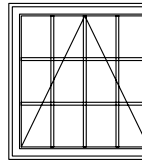

VL10T038039

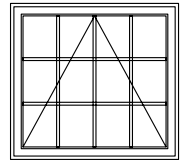

VL10T042039

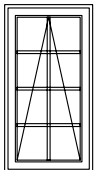

VL10T022042

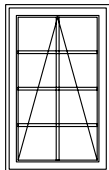

VL10T026042

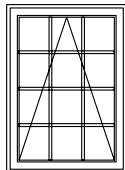

VL10T030042

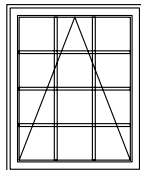

VL10T034042

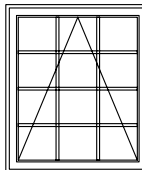

VL10T036042

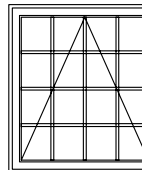

VL10T038042

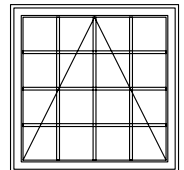

VL10T042042

Dim.Col.  
RISO  
CADRE  
VERRE  
FRAME  
GLASS

23 3/4" • 603mm  
23" • 584mm  
16 5/8" • 422mm

31 3/4" • 806mm  
31" • 787mm  
24 5/8" • 625mm

39 3/4" • 1010mm  
39" • 991mm  
32 5/8" • 829mm

42 3/4" • 1086mm  
42" • 1067mm  
35 5/8" • 905mm

46 3/4" • 1187mm  
46" • 1168mm  
39 5/8" • 1006mm

48 3/4" • 1238mm  
48" • 1219mm  
41 5/8" • 1057mm

50 3/4" • 1289mm  
50" • 1270mm  
43 5/8" • 1108mm

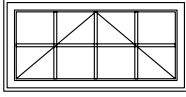

VL10T046023

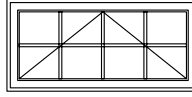

VL10T048023

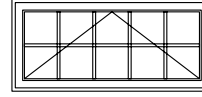

VL10T050023

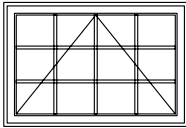

VL10T046031

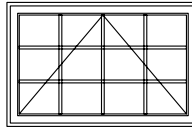

VL10T048031

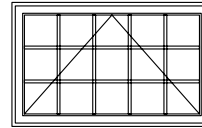

VL10T050031

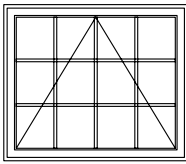

VL10T046039

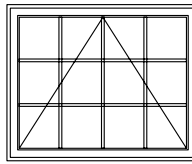

VL10T048039

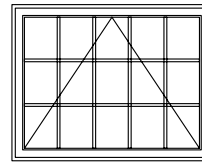

VL10T050039

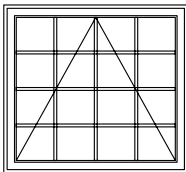

VL10T046042

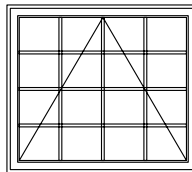

VL10T048042

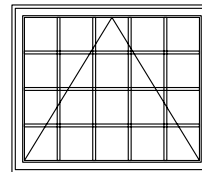

VL10T050042

Dim. Col.  
RSD  
FRAME CADRE  
GLASS VERRRE

22 3/4" • 578mm  
22" • 559mm  
15 5/8" • 397mm

26 3/4" • 679mm  
26" • 660mm  
19 5/8" • 498mm

30 3/4" • 781mm  
30" • 762mm  
23 5/8" • 600mm

34 3/4" • 883mm  
34" • 864mm  
27 5/8" • 702mm

38 3/4" • 984mm  
38" • 965mm  
31 5/8" • 803mm

42 3/4" • 1086mm  
42" • 1067mm  
35 5/8" • 905mm

54 3/4" • 1391mm  
54" • 1372mm  
16 5/8" • 422mm \*\* 24 5/8" • 625mm

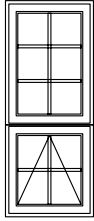

VL10BT022054

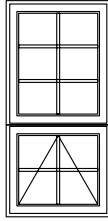

VL10BT026054

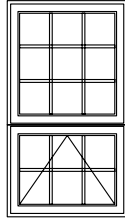

VL10BT030054

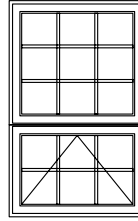

VL10BT034054

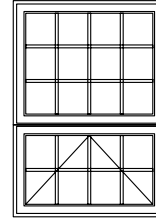

VL10BT038054

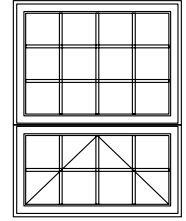

VL10BT042054

62 3/4" • 1594mm  
62" • 1575mm  
16 5/8" • 422mm \*\* 32 5/8" • 829mm

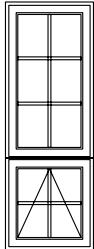

VL10BT022062

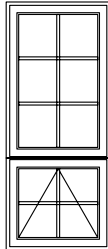

VL10BT026062

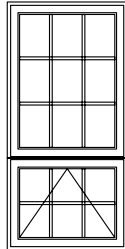

VL10BT030062

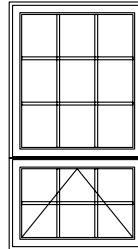

VL10BT034062

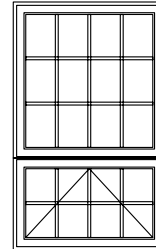

VL10BT038062

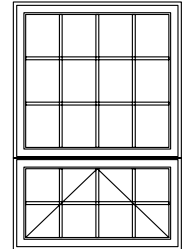

VL10BT042062

70 3/4" • 1797mm  
70" • 1778mm  
16 5/8" • 422mm \*\* 40 5/8" • 1032mm

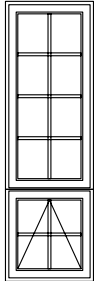

VL10BT022070

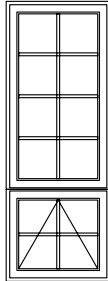

VL10BT026070

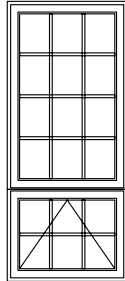

VL10BT030070

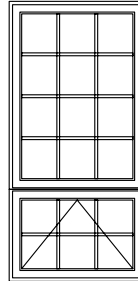

VL10BT034070

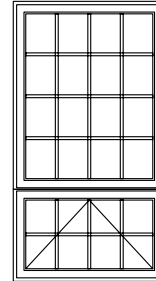

VL10BT038070

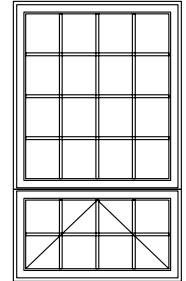

VL10BT042070

78 3/4" • 2000mm  
78" • 1981mm  
16 5/8" • 422mm \*\* 48 5/8" • 1235mm

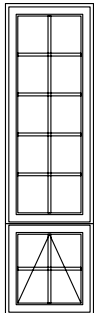

VL10BT022078

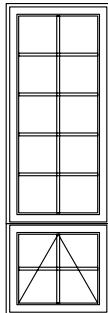

VL10BT026078

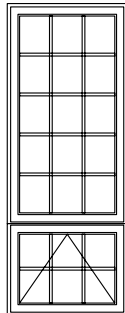

VL10BT030078

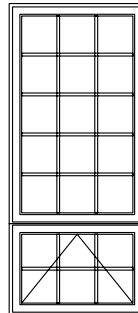

VL10BT034078

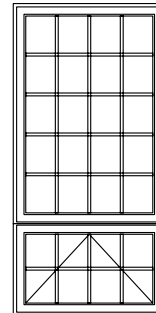

VL10BT038078

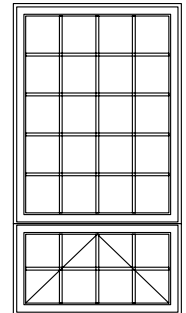

VL10BT042078



# Architectural Detail manual

## Awning window DF3113

All vinyl

Dim.Col.  
FRAME CADRE  
GLASS VERRE

46 3/4" • 1187mm  
48" • 1188mm  
39 5/8" • 1006mm

50 3/4" • 1289mm  
50" • 1270mm  
43 5/8" • 1108mm

54 3/4" • 1391mm  
54" • 1168mm  
16 5/8" • 422mm \*\* 24 5/8" • 625mm

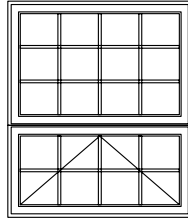

VL10BT046054

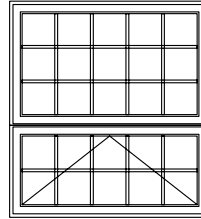

VL10BT050054

62 3/4" • 1594mm  
62" • 1575mm  
16 5/8" • 422mm \*\* 32 5/8" • 829mm

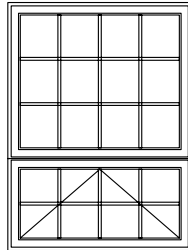

VL10BT046062

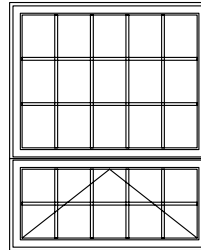

VL10BT050062

70 3/4" • 1797mm  
70" • 1778mm  
16 5/8" • 422mm \*\* 40 5/8" • 1032mm

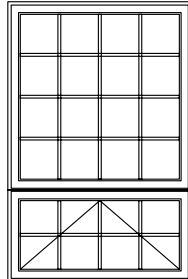

VL10BT046070

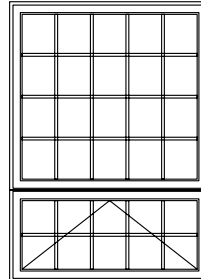

VL10BT050070

78 3/4" • 2000mm  
78" • 1981mm  
16 5/8" • 422mm \*\* 48 5/8" • 1235mm

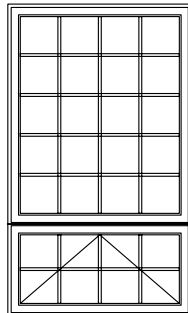

VL10BT046078

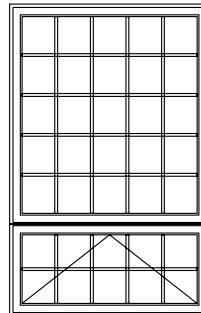

VL10BT050078

Dim.Col.  
RSO  
CADRE  
FRAME  
GLASS  
VERRE

22 3/4" • 578mm  
22" • 559mm  
15 5/8" • 397mm

26 3/4" • 679mm  
26" • 660mm  
19 5/8" • 498mm

30 3/4" • 781mm  
30" • 762mm  
23 5/8" • 600mm

34 3/4" • 883mm  
34" • 864mm  
27 5/8" • 702mm

38 3/4" • 984mm  
38" • 965mm  
31 5/8" • 803mm

42 3/4" • 1086mm  
42" • 1067mm  
35 5/8" • 905mm

38 3/4" • 603mm  
38" • 584mm  
12 5/8" • 321mm

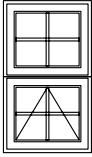

VL10CT022038

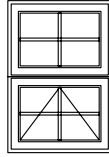

VL10CT026038

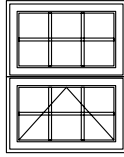

VL10CT030038

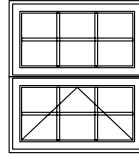

VL10CT034038

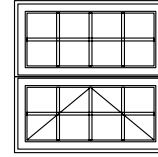

VL10CT038038

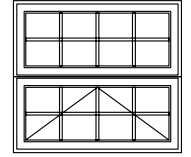

VL10CT042038

46 3/4" • 1187mm  
46" • 1168mm  
16 5/8" • 422mm

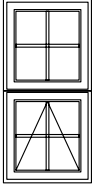

VL10CT02246

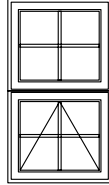

VL10CT02646

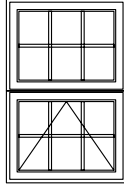

VL10CT03046

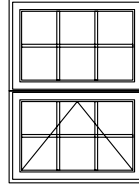

VL10CT03446

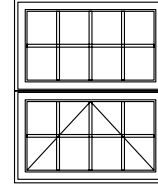

VL10CT03846

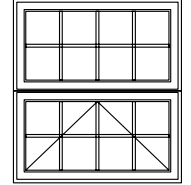

VL10CT04246

54 3/4" • 1391mm  
54" • 1372mm  
20 5/8" • 524mm

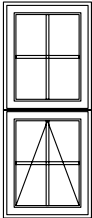

VL10CT022054

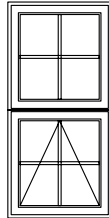

VL10CT026054

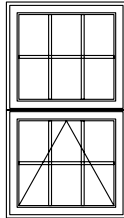

VL10CT030054

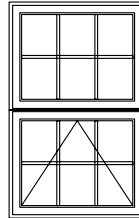

VL10CT034054

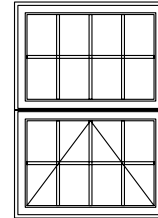

VL10CT038054

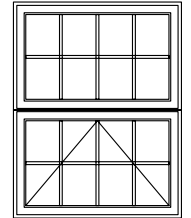

VL10CT042054

62 3/4" • 1594mm  
62" • 1575mm  
24 5/8" • 625mm

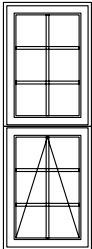

VL10CT022062

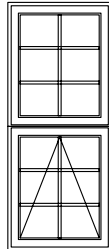

VL10CT026062

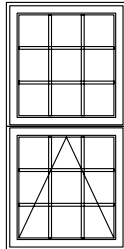

VL10CT030062

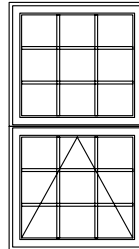

VL10CT034062

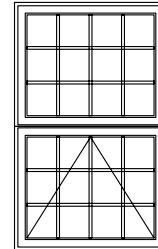

VL10CT038062

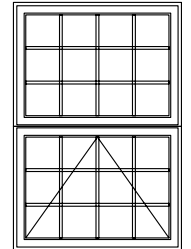

VL10CT042062

70 3/4" • 1797mm  
70" • 1778mm  
28 5/8" • 727mm

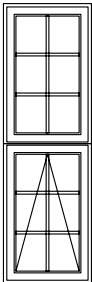

VL10CT022070

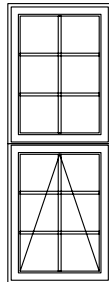

VL10CT026070

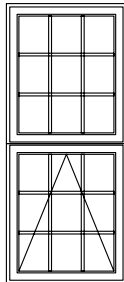

VL10CT030070

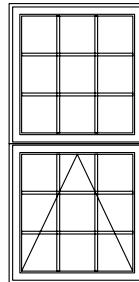

VL10CT034070

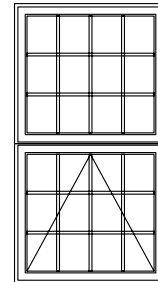

VL10CT038070

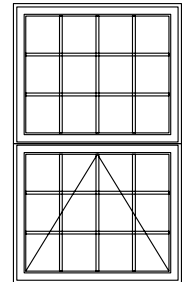

VL10CT042070

78 3/4" • 2000mm  
78" • 1981mm  
32 5/8" • 829mm

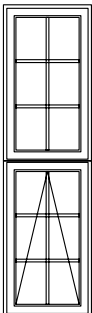

VL10CT022078

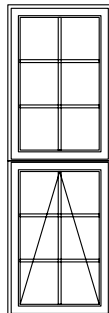

VL10CT026078

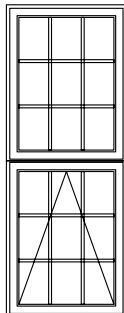

VL10CT030078

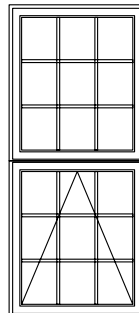

VL10CT034078

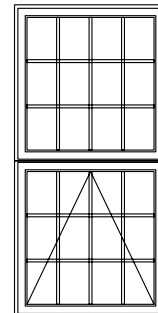

VL10CT038078

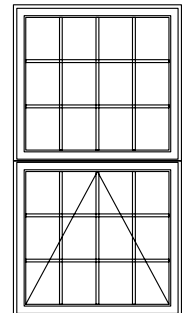

VL10CT042078

# Architectural Detail manual

## Awning window DF3113

All vinyl

Dim.Col.  
RSO  
CADRE  
FRAME  
GLASS  
VERRE

46 3/4" • 1187mm  
46" • 1168mm  
39 5/8" • 1006mm

50 3/4" • 1289mm  
50" • 1270mm  
43 5/8" • 1108mm

36 9/16" • 903mm  
36" • 914mm  
12 5/8" • 321mm

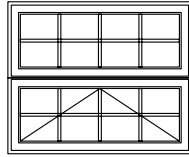

VL10CT046038

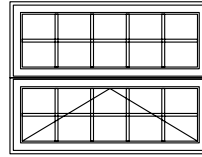

VL10CT050038

46 9/16" • 1187mm  
46" • 1168mm  
16 5/8" • 422mm

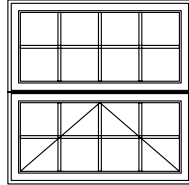

VL10CT04646

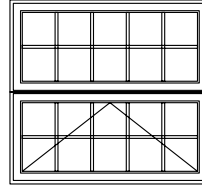

VL10CT05046

54 9/16" • 1391mm  
54" • 1380mm  
20 5/8" • 524mm

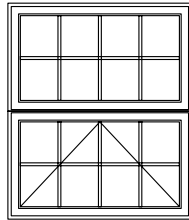

VL10CT046054

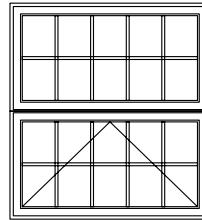

VL10CT050054

62 9/16" • 1594mm  
62" • 1584mm  
24 5/8" • 625mm

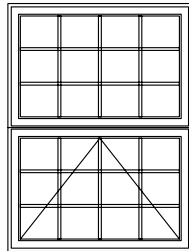

VL10CT046062

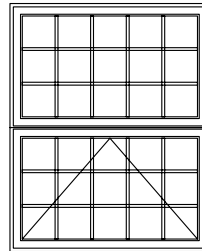

VL10CT050062

70 3/16" • 1797mm  
70" • 1778mm  
28 5/8" • 727mm

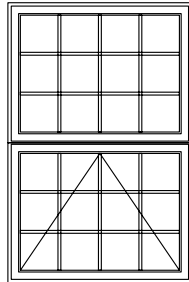

VL10CT046070

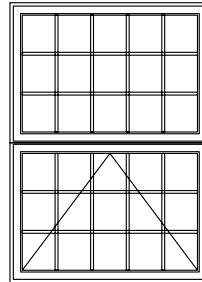

VL10CT050070

78 9/16" • 2000mm  
78" • 1990mm  
32 5/8" • 828mm

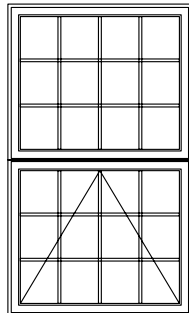

VL10CT046078

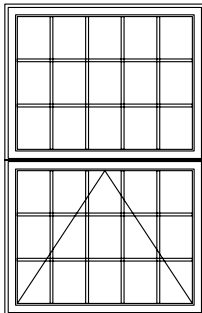

VL10CT050078

AWNING GLAZING OPTIONS

Carrelage amovible \_\_\_\_\_  
*Removable grilles*

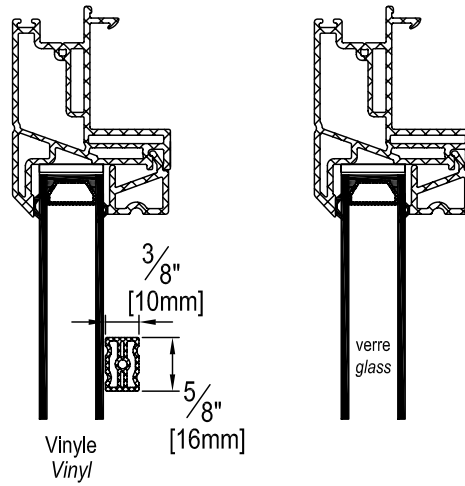

AWNING GLAZING OPTIONS

Carrelage scellé  
*Internal grilles*

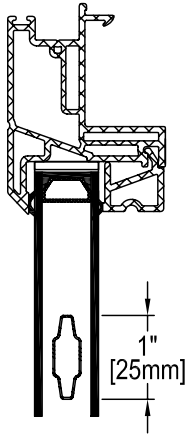

Georgian 1"

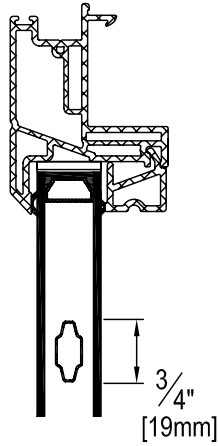

Georgian

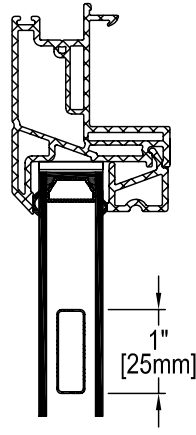

Plat 1"  
1" Flat

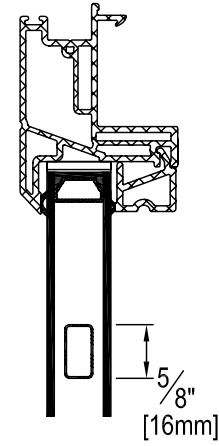

Plat  
Flat

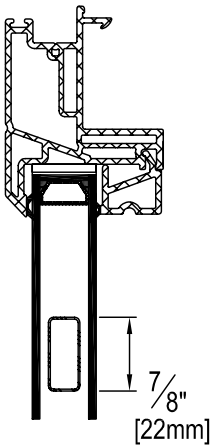

Intercalaire  
Spacer bar

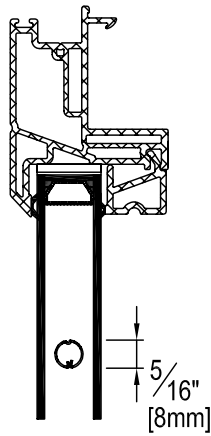

Tubulaire  
Pencil bar

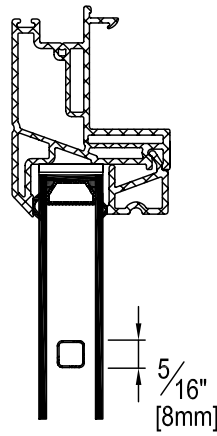

Carré  
Square

**AWNING GLAZING OPTIONS (TRIPLE GLASS)**

Carrelage scellé  
*Internal grilles*

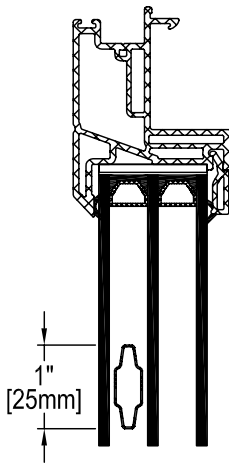

Georgian 1"

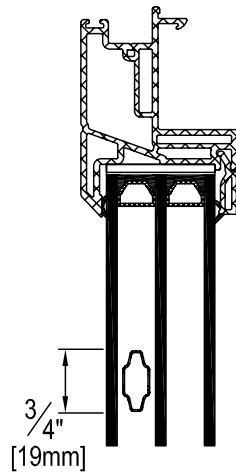

Georgian

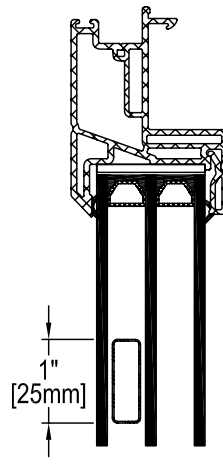

Plat 1"  
1" Flat

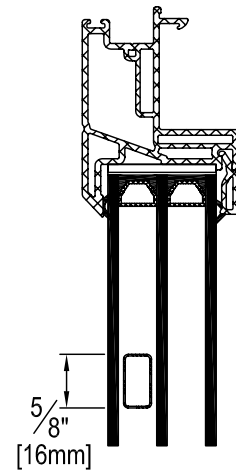

Plat  
Flat

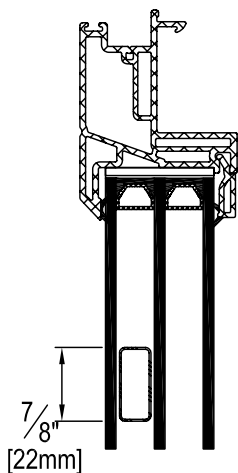

Intercalaire  
Spacer bar

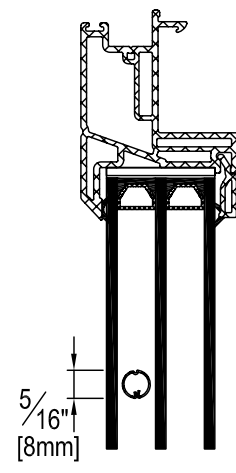

Tubulaire  
Pencil bar

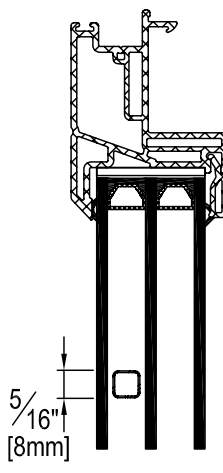

Carré  
Square

AWNING GLAZING OPTIONS

Simili barrotin avec intercalaire  
*Simulated divided lite with spacer-bar*

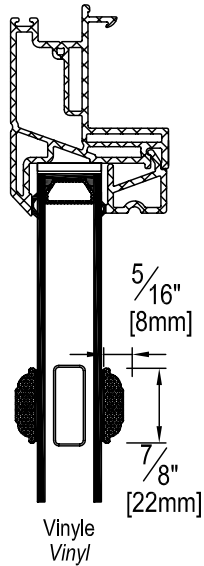

Simili barrotin  
*Simulated divided lite*

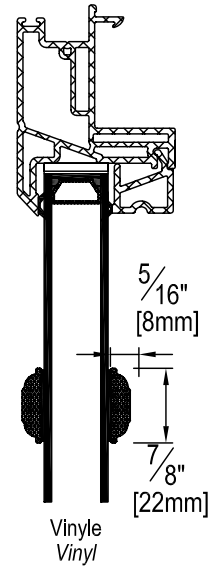

AWNING GLAZING OPTIONS (TRIPLE VERRE)

Simili barrotin avec intercalaire  
*Simulated divided lite with spacer-bar*

Simili barrotin  
*Simulated divided lite*

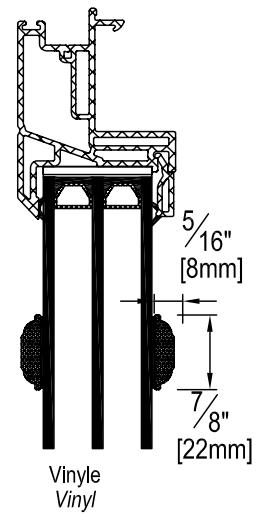
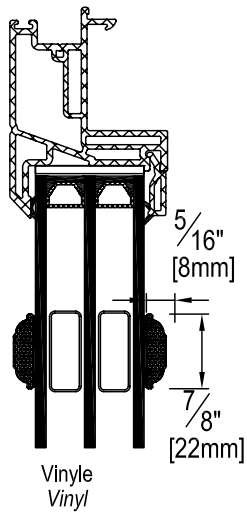



AWNING GLAZING OPTIONS

Faux-meneau avec intercalaire  
*False mullion with spacer-bar*

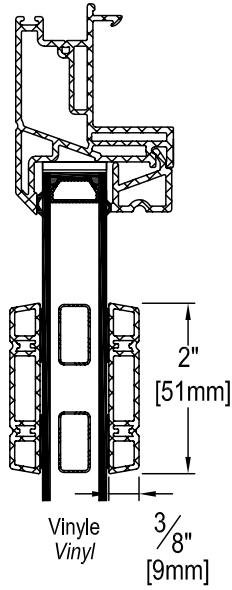

Faux-meneau  
*False mullion*

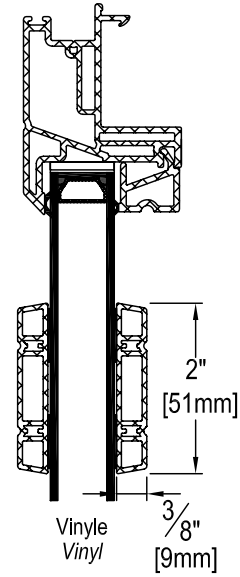

ALL VINYL AWNING TRIM OPTIONS

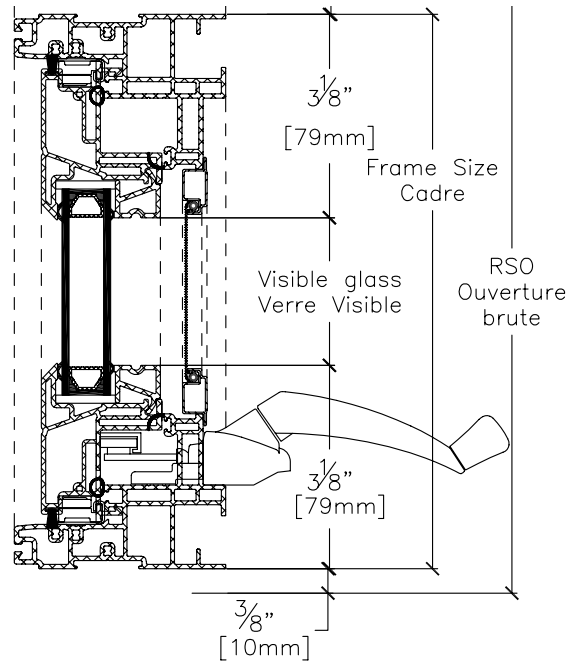

3 1/4" #400  
3 1/4" flush frame #400

ALL VINYL AWNING TRIM OPTIONS

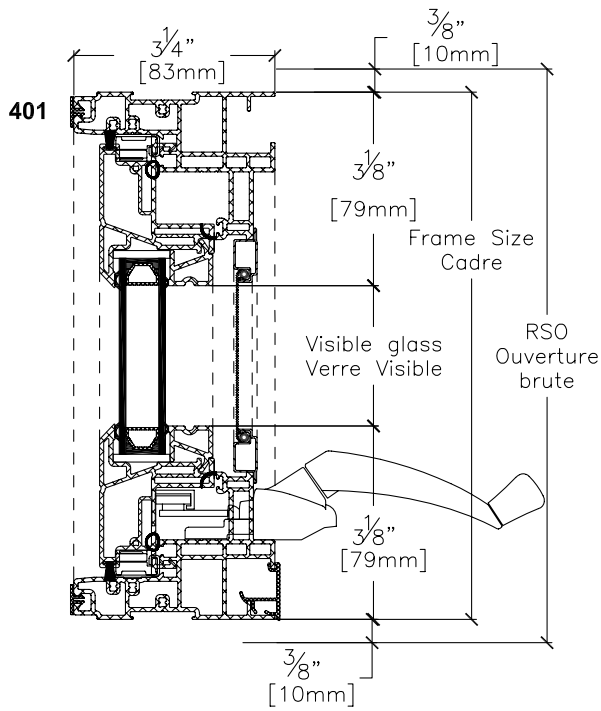

3 1/4" avec 401  
3 1/4" with 401

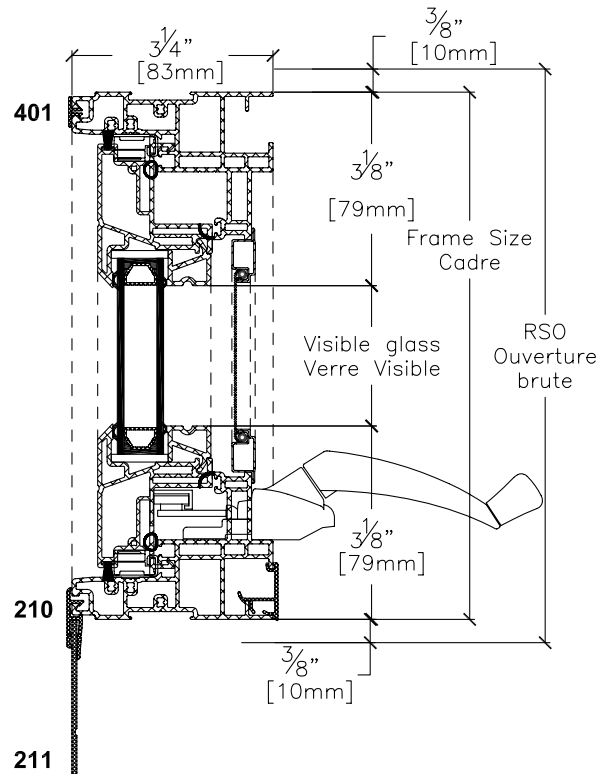

3 1/4" avec 401-210-211  
3 1/4" with 401-210-211

**ALL VINYL AWNING TRIM OPTIONS**

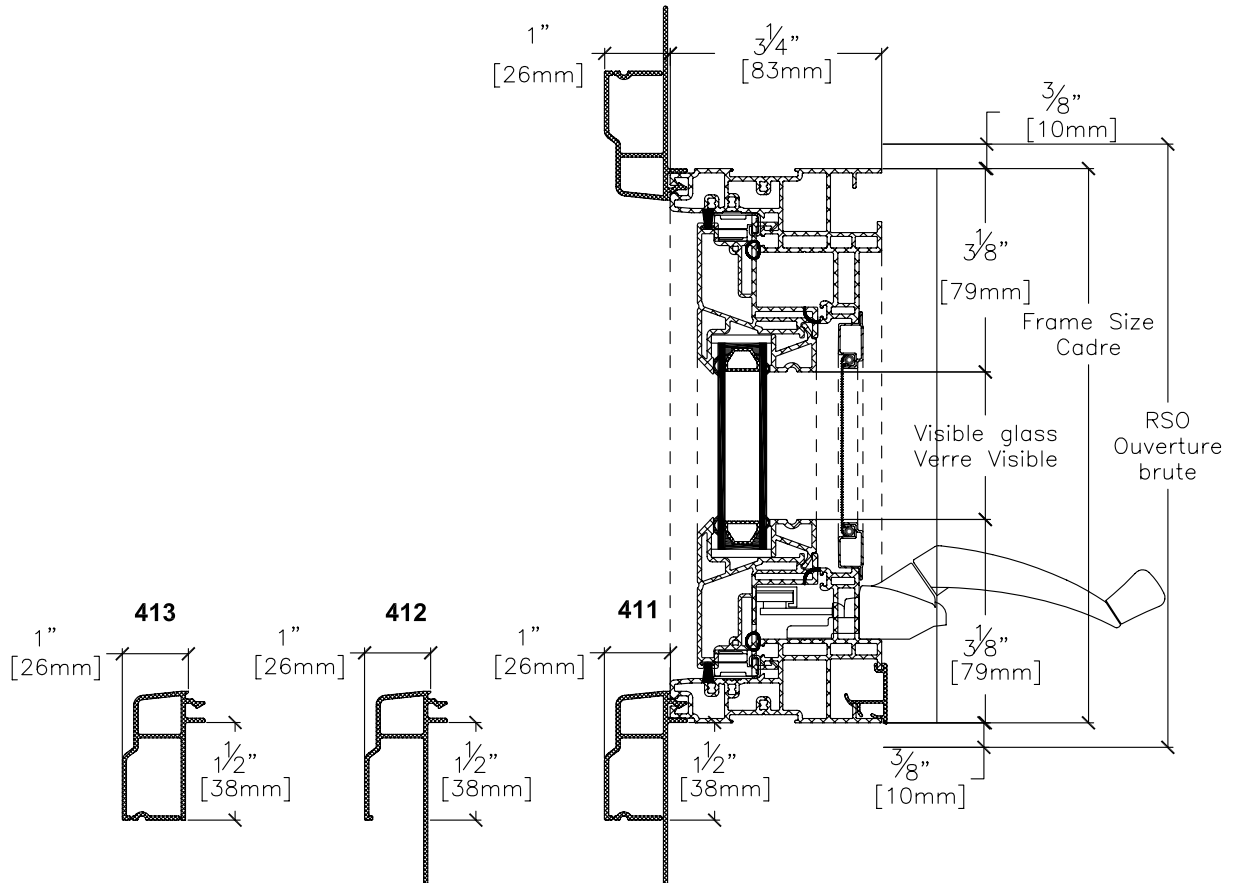

3 1/4" avec 411-412-413  
3 1/4" with 411-412-413

ALL VINYL AWNING TRIM OPTIONS

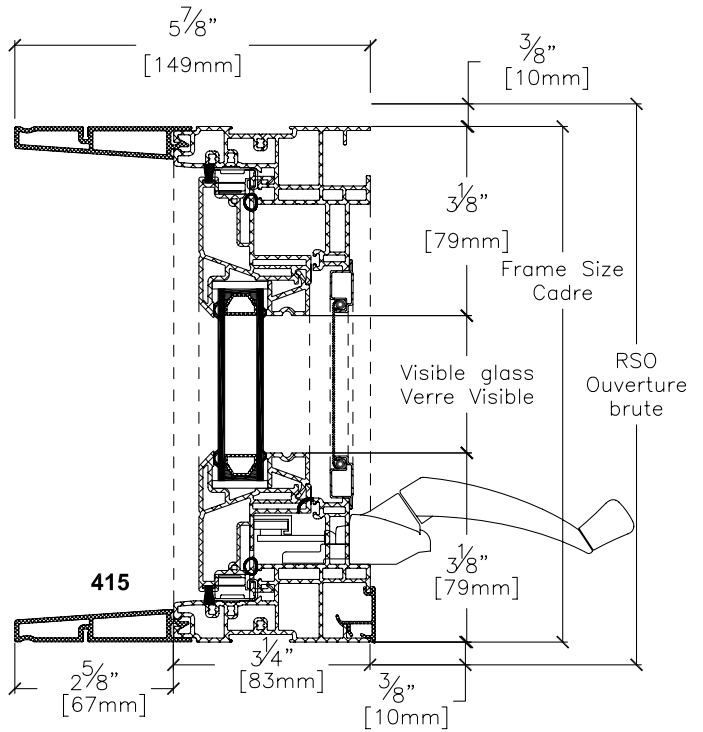
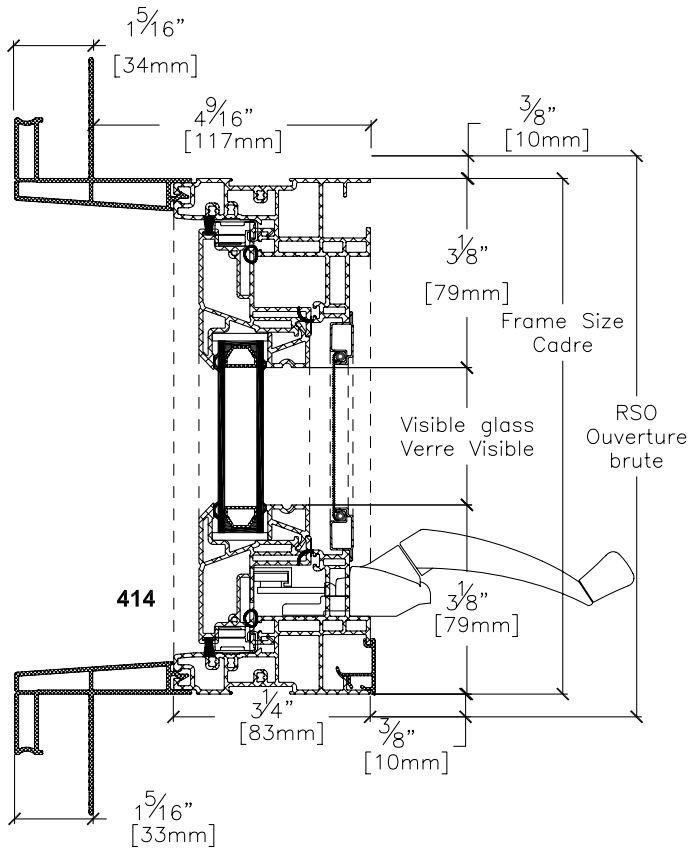

4 9/16" avec 414  
4 9/16" with 414

4 9/16" avec 415  
4 9/16" with 415

ALL VINYL AWNING TRIM OPTIONS

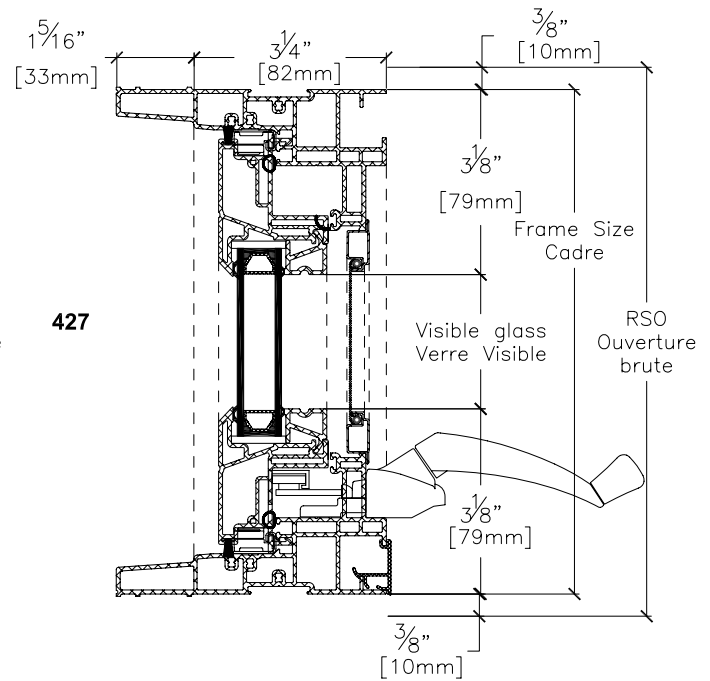
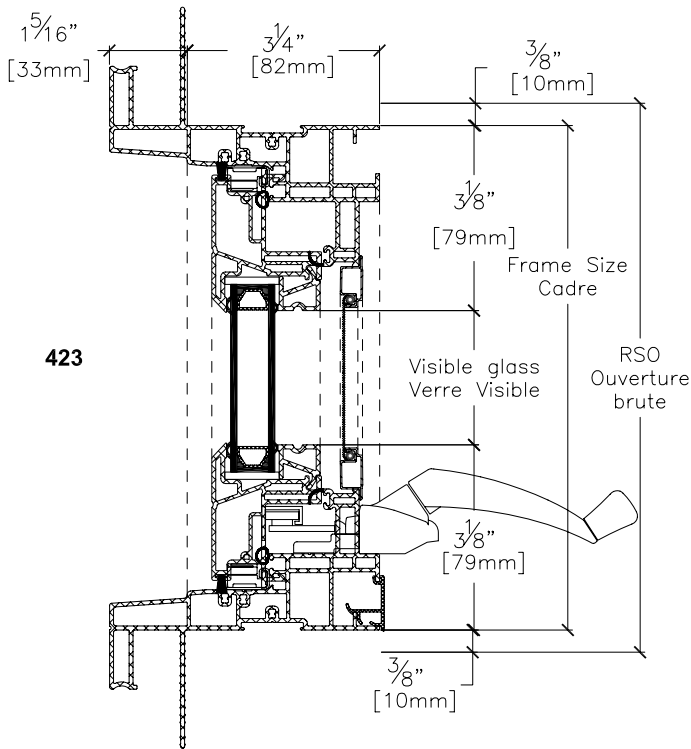

3 1/4" avec 423 intégrée  
3 1/4" with 423 integral

4 9/16" avec 427 intégrée  
4 9/16" with 427 integral

ALL VINYL AWNING TRIM OPTIONS

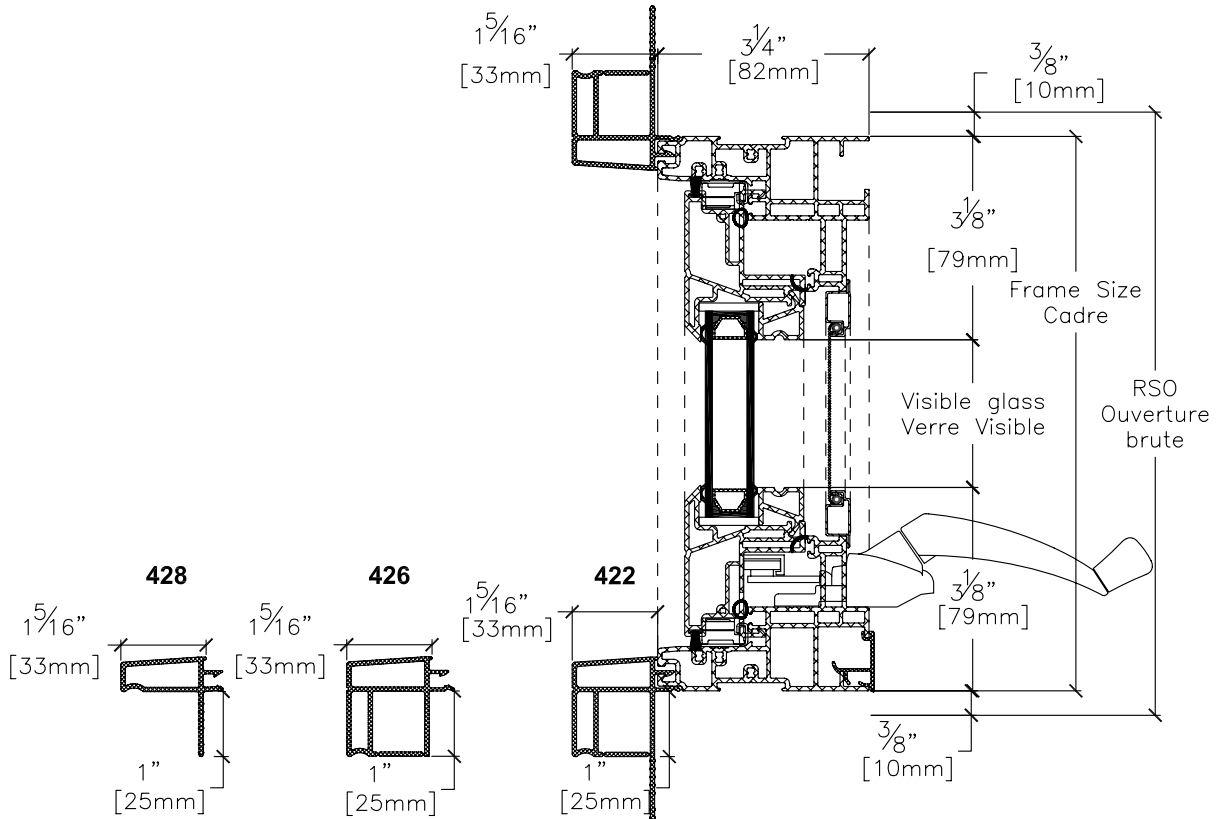

3 1/4" avec 422-426-428

3 1/4" with 422-426-428

ALL VINYL AWNING TRIM OPTIONS

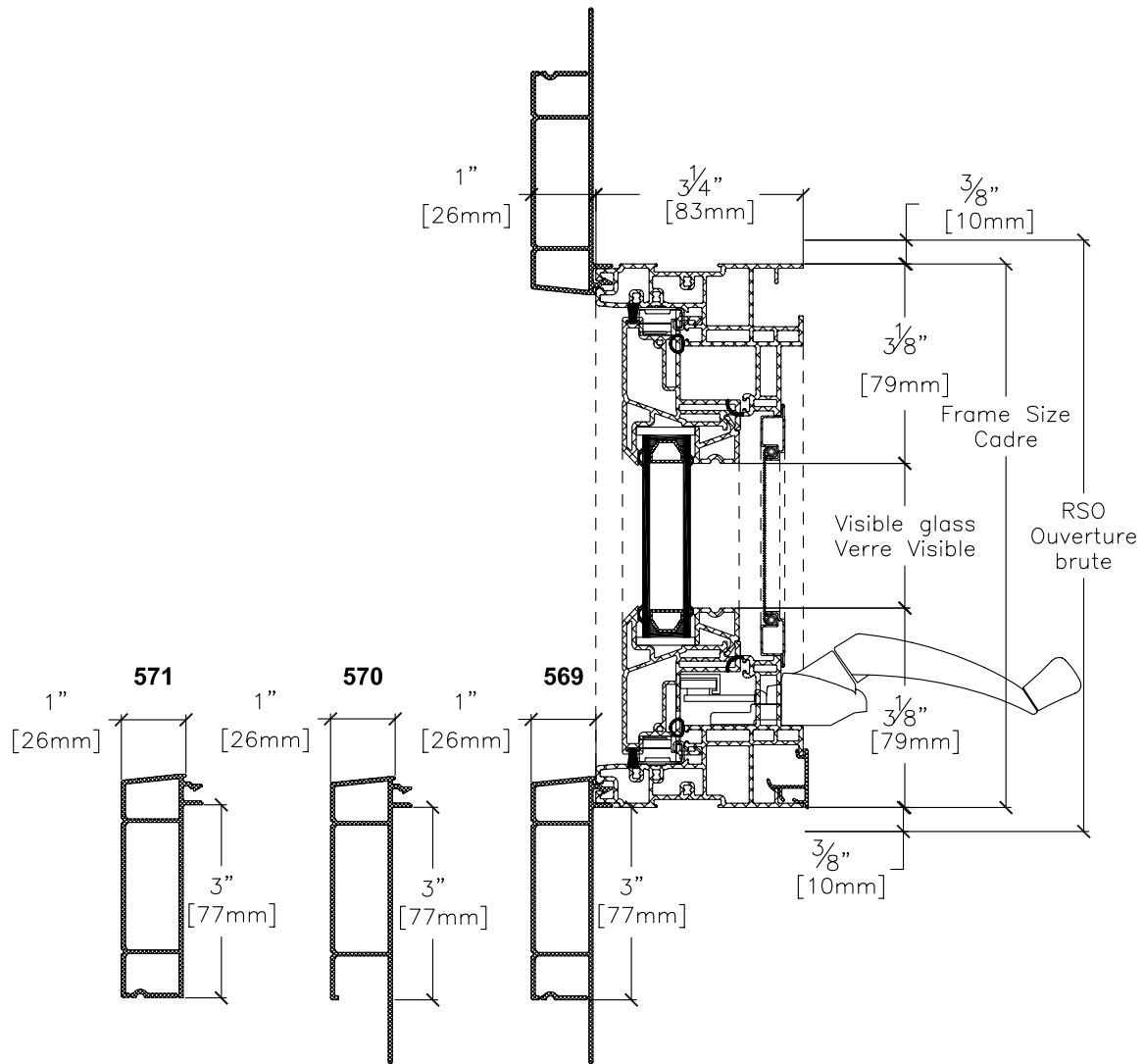

3 1/4" avec 569-570-571  
3 1/4" with 569-570-571



NATURAL JAMB EXTENDER OPTIONS

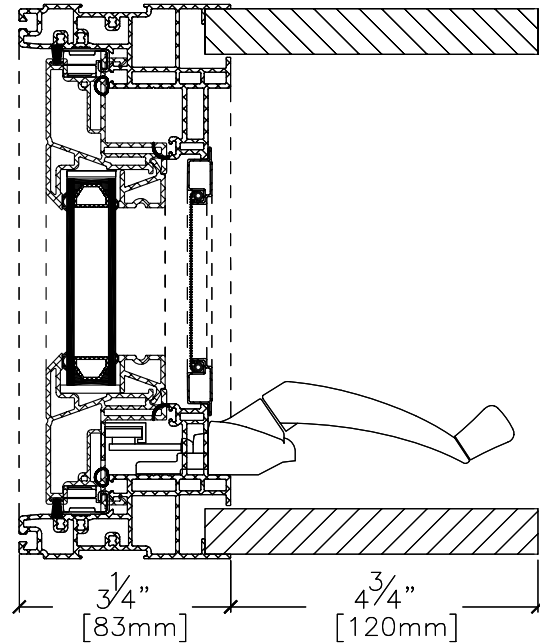
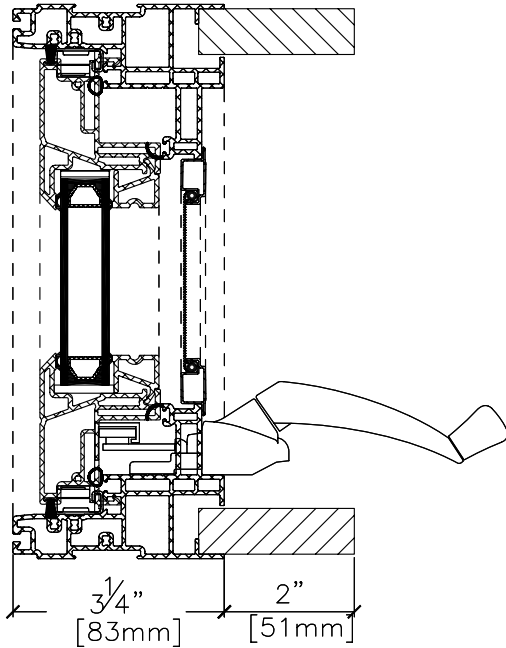

VINYL CLAD JAMB EXTENDER OPTIONS

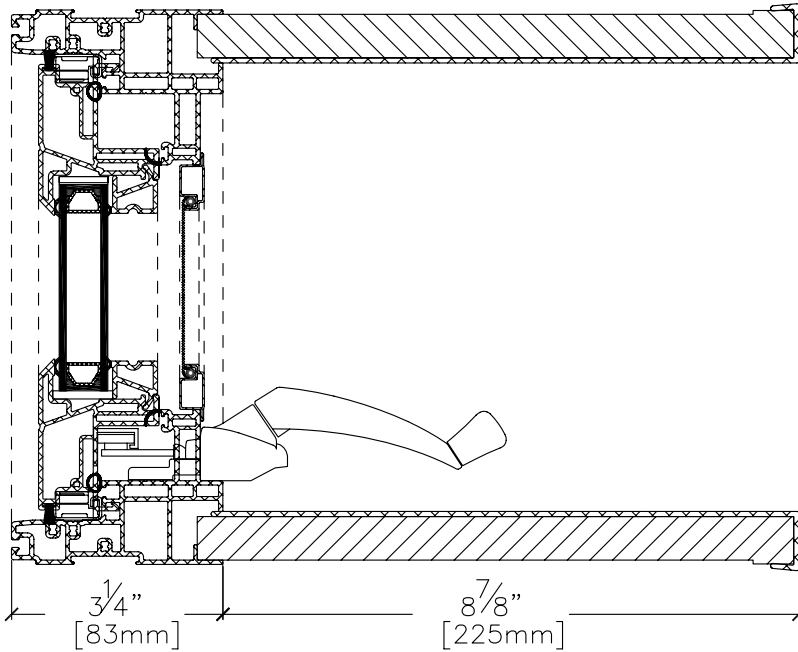
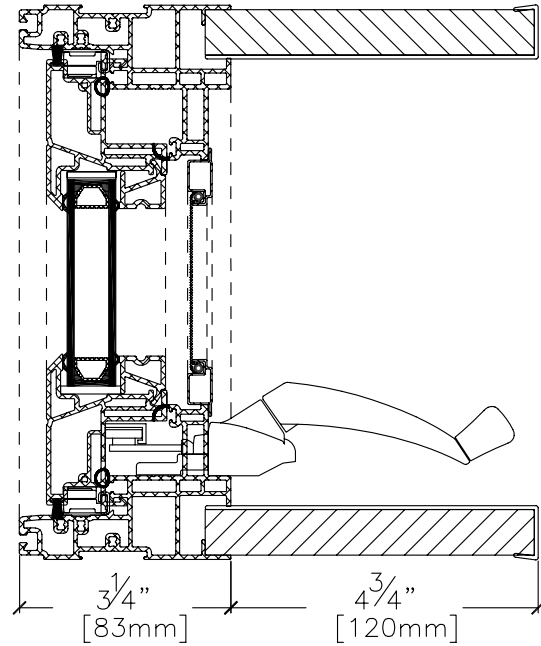
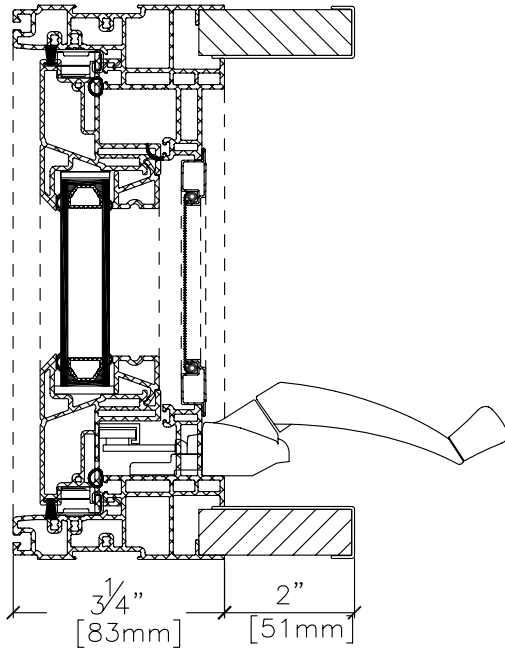

STANDARD MULLION DETAILS

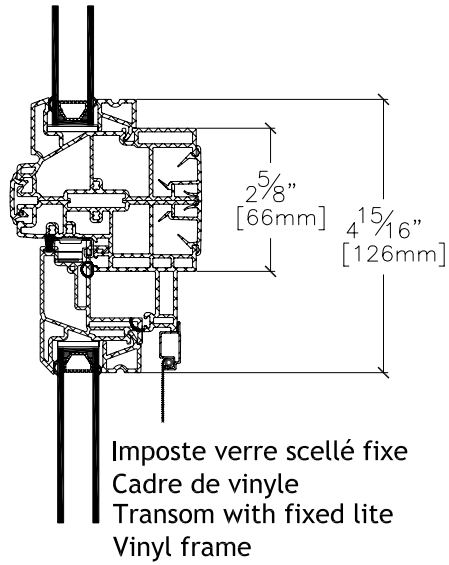

OTHER MULLION DETAILS

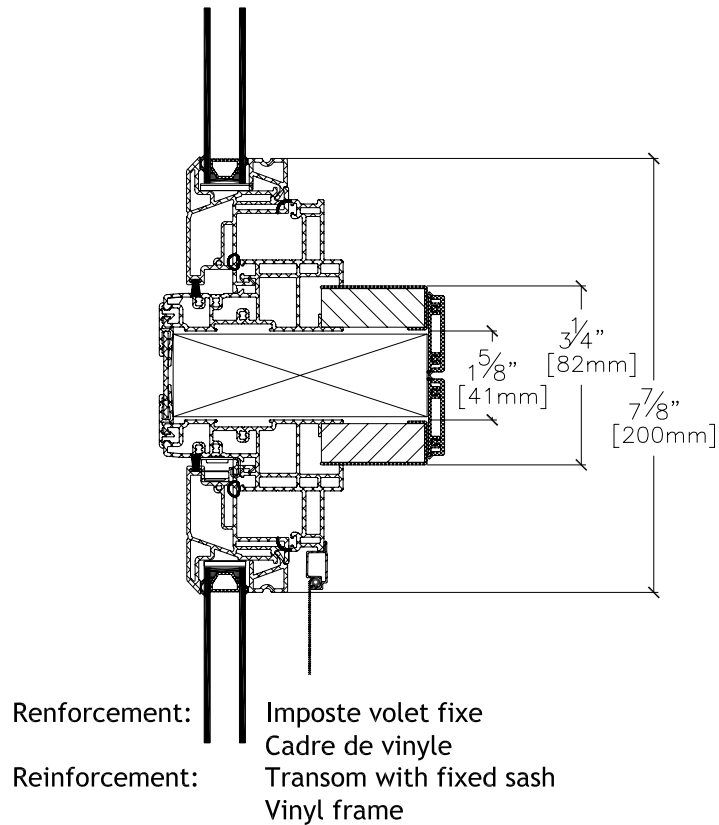

## LITE CUT INFORMATION

All vinyl awning windows are available with removable grilles, GBG (Grilles between the Glass), 7/8" Simulated Divided Lites and 2" False Mullion.

### LITE CUT OPTIONS

Special lite cut patterns can include a wide variety of straight line and radius patterns. The illustrations shown here represent just a few of the possibilities. Rectangular, horizontal, vertical and Prairie lite patterns are available in awning windows. Uneven, diamond, radius and Gothic lite cuts are available, subject to approval. Approvals are based on the ability to fulfill the design requirement while maintaining the construction integrity of the finished product.

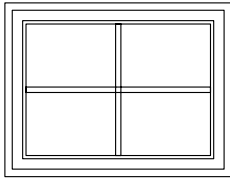

Rectangulaire  
Rectangular

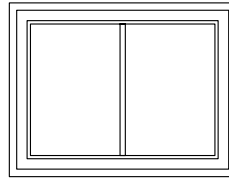

Verticale  
Vertical

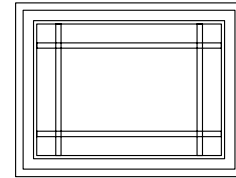

Prairie  
Prairie

### BAR ALIGNMENT

Alignment of muntin bars from one window to the next is often required by fine architectural design. Wood grilles, GBG (Grilles between the Glass), Simulated Divided Lites and False Mullion may be specified with muntin bars aligned.

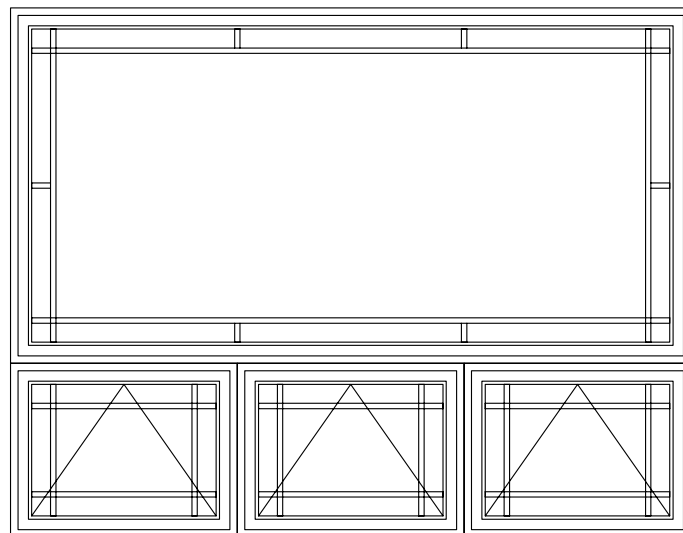

### Combination Assemblies

#### Combination Units - All Vinyl Awning

JELD-WEN vinyl Awning Windows can be grouped in almost an infinite number of combinations. They can be mullered directly alongside other operating or fixed awnings. Stack them on top or below one another or as part of an elegant Half Round or Quarter Round assembly. Combining them with angular or rectangular Geometrics can create a majestic look. Adding "SDL" (simulated divided lites) or grilles, will accent or provide special effects to your assembly. If standard sizes do not meet your opening requirements, custom sizes may be specified.

Where applications require structural support in the assembly itself, or in the wall section, units may be separated by a specified dimension. If the separation is desired for appearance only, the specified dimension is considered a "spreadmull" and contain filler blocks between the units. In either case, the units are factory assembled and come with exterior and interior mull covers.

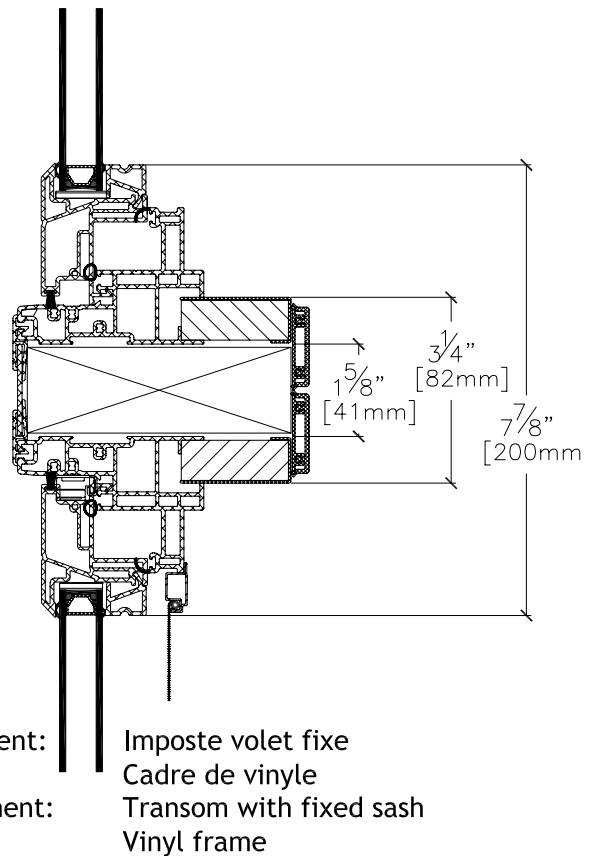
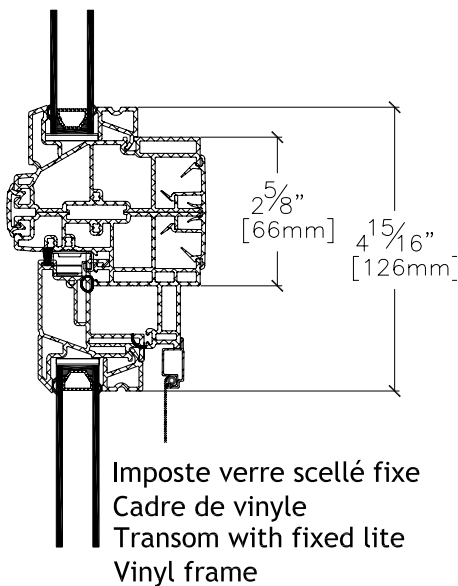

#### • How to determine Rough Openings of Multiple Assemblies:

JELD-WEN uses a Rough Opening allowance of 3/4" wider and 3/4" higher than the window assembly. (Contact your Dealer or JELD-WEN for special considerations for angular unit rough openings.)

1. Obtain Frame Dimensions of the units to be mullered.
2. Add Frames together along with any spread mulls.
3. Add 3/4" to the width and 3/4" to the height.

#### • Example:

R.O. for VL20T068042 with a VL20T068023 stacked above.

- #1: **Width:** The frame width 68"; add 3/4" for R.O. allowance = 68 3/4"  
**Height:** Add the frame height 23" to the frame height 42"; add 3/4" for R.O. allowance = 65 3/4"
- #2: **Width:** The frame width 68"; add 3/4" for R.O. allowance = 68 3/4"  
**Height:** Add the frame height 23" to the frame height 42"; add 1 5/8" for reinforcement; add 3/4" for R.O. allowance = 67 3/8"

# Architectural Detail manual

## Awning window DF3113

All vinyl

### Clear Opening and Daylight Specifications

#### DF3113 all vinyl

Unit No.	Daylight Opening		Length of wetherstrip		Unit	
	Sq. Ft	Sq. met.	lin. Ft	lin. met.	Sq. Ft	Sq. met.
VL10T022 023	1,8	0,17	6,7	2,0	3,5	0,33
VL10T022 031	2,7	0,25	8,0	2,4	4,7	0,44
VL10T022 039	3,5	0,33	9,3	2,8	6,0	0,55
VL10T022 042	3,9	0,36	9,8	3,0	6,4	0,60
VL10T026 023	2,3	0,21	7,3	2,2	4,2	0,39
VL10T026 031	3,4	0,31	8,7	2,6	5,6	0,52
VL10T026 039	4,4	0,41	10,0	3,0	7,0	0,65
VL10T026 042	4,9	0,45	10,5	3,2	7,6	0,70
VL10T030 023	2,7	0,25	8,0	2,4	4,8	0,45
VL10T030 031	4,0	0,38	9,3	2,8	6,5	0,60
VL10T030 039	5,4	0,50	10,7	3,2	8,1	0,75
VL10T030 042	5,8	0,54	11,2	3,4	8,8	0,81
VL10T034 023	3,2	0,30	8,7	2,6	5,4	0,50
VL10T034 031	4,7	0,44	10,0	3,0	7,3	0,68
VL10T034 039	6,3	0,58	11,3	3,5	9,2	0,86
VL10T034 042	6,8	0,63	11,8	3,6	9,9	0,92
VL10T036 023	3,4	0,32	9,0	2,7	5,8	0,53
VL10T036 031	5,1	0,47	10,3	3,1	7,8	0,72
VL10T036 039	6,7	0,62	11,7	3,6	9,8	0,91
VL10T036 042	7,3	0,68	12,2	3,7	10,5	0,98
VL10T038 023	3,7	0,34	9,3	2,8	6,1	0,56
VL10T038 031	5,4	0,50	10,7	3,2	8,2	0,76
VL10T038 039	7,2	0,67	12,0	3,7	10,3	0,96
VL10T038 042	7,8	0,73	12,5	3,8	11,1	1,03
VL10T042 023	4,1	0,38	10,0	3,0	6,7	0,62
VL10T042 031	6,1	0,57	11,3	3,5	9,0	0,84
VL10T042 039	8,1	0,75	12,7	3,9	11,4	1,06
VL10T042 042	8,8	0,82	13,2	4,0	12,3	1,14
VL10T046 023	4,6	0,42	10,7	3,2	7,3	0,68
VL10T046 031	6,8	0,63	12,0	3,7	9,9	0,92
VL10T046 039	9,0	0,83	13,3	4,1	12,5	1,16
VL10T046 042	9,8	0,91	13,8	4,2	13,4	1,25
VL10T048 066	17,2	1,60	18,2	5,5	22,0	2,04
VL10T048 070	18,4	1,71	18,8	5,7	23,3	2,17
VL10T048 074	19,5	1,82	19,5	5,9	24,7	2,29
VL10T048 078	20,7	1,92	20,2	6,1	26,0	2,42
VL10T050 066	18,1	1,68	18,5	5,6	22,9	2,13
VL10T050 070	19,3	1,79	19,2	5,8	24,3	2,26
VL10T050 074	20,5	1,90	19,8	6,0	25,7	2,39
VL10T050 078	21,7	2,02	20,5	6,2	27,1	2,52