

## MATERIALS

Extruded vinyl profiles comply with the performance requirements of AAMA 303-97. Colour is White.

## FRAME

All frames are assembled utilizing fusion-welded technology for added strength and durability. Frame jamb depth is 3-1/4" (83mm), and the exterior wall thickness is 0.065 of an inch. Frames come standard with an accessory groove to accommodate exterior mouldings and with an open integrated 1/2-3/4" return. A closed version is also available for replacement purposes.

## SASH

Sashes are 1-1/2" (nominal) or (38.1mm) thick, and are assembled utilizing fusion-welded technology for added strength and durability.

## GLAZING

3/4" (19mm) insulating glass consists of two lites of glass sealed around a warm edge spacer. All insulating glass units comply with the performance requirements of the IGMAC in accordance with either CAN/CGSB-12.8-97.

## GLAZING OPTIONS

3/4" (19mm) insulated glass available in clear, Low-E with Argon, tinted, frosted, or other specialty insulating glass as specified. All glass is available tempered.

## WEATHER-STRIPPING

Fin pile weatherstrip applied along the full perimeter of operating sashes. Weatherstrips meet the AAMA 701 or AAMA 702.

## HARDWARE

Double sliders utilize teflon blocks to slide back and forth on the tracks. A white metal cast camlock is surface mounted. For a width of 39 7/16" or more, 2 camlocks are installed. Both sashes lift out for ease of cleaning. A pull rail is integral to the sash.

## EXTERIOR INSECT SCREENS

Fiberglass charcoal colour insect screen in an aluminium frame to match the colour of the unit. Insect screens are intended to allow air and light in and to keep insects out. They are not intended to keep anyone or anything from falling through an open window. For safety screens or other security devices contact your local building supply retailer. Standard is half screen, full size screen available upon request.

## GRILLES

Vinyl SDL (Simulated Divided Lite) - 7/8" (23mm) permanently applied on both sides of insulating glass with or without spacer bar between the glass panes.

Internal Grilles (Grilles between the Glass) - Georgian, pencil bar, square or flat mounted between the glass panes suspended within the air cavity.

Please note: Removable grilles are not available in the slider series nor false mullions.

## INSTALLATION

Installation per JELD-WEN Installation Method for All Vinyl Windows. See [www.jeld-wen.com/resources](http://www.jeld-wen.com/resources) for instructions.

## PERFORMANCE

CSA-Certified - (rated and labeled in accordance with CSA) certification program  
NFRC Certified - (rated and labeled in accordance with NFRC)

Quick SPEC Guide

Specification	Standard features	Optional features Some options may require additional lead times. Consult your JELD-WEN Sales Representative.
Colour	White	Painted exterior - white interior A-06 Maize A-71 Dark Clay A-34 Savanna A-72 Canyon Clay A-42 Hickory A-74 Sandalwood A-43 Cashmere A-75 Wicker A-44 Mist Blue A-79 Tan A-51 Sumac CL-025 Clay A-53 Arcadian IV-050 Almond
Size	- Width: 24" to 74" - Height: 15" to 48"	• Any size with minimum and maximum parameters
Frame	• Exterior accessory groove • Open frame 1/2-3/4" return	
Exterior Trim	• Exterior accessory groove	#401 - Exterior finish trim #411 - 1" x 2" brickmould with nailing flange (no 'J' channel) #412 - 1" x 2" brickmould with 'J' channel and nailing flange #413 - 1" x 2" brickmould #414 - 1 5/16" extension with brickmould, 'J' channel and nailing flange (for 4 9/16" frame) #415 - 2 5/8" extension #422 - Brickmould and nailing flange (no 'J' channel) #423 - Brickmould, 'J' channel and nailing flange ( <b>integral</b> ) #426 - Brickmould #427 - 1 5/16" extension ( <b>integral</b> ) #428 - 1 5/16" exterior finish trim and nailing flange #569 - 1" x 3 1/2" brickmould with nailing flange (no 'J' channel) #570 - 1" x 3 1/2" brickmould with 'J' channel and nailing flange #571 - 1" x 3 1/2" brickmould finish trim #210 - Adaptor for sill expander (in 16 foot lengths only) not installed #211 - 3 3/4" sill expander (in 16 foot lengths only) not installed
Glazing	• Insulating Clear with warm edge spacer	- Low-E - Satin - Bronze - Grey - Frosted (pinhead Morocco) - Gluechip - Laminated - All glass available tempered
Hardware	• Camlock	
Hardware Colour	• White	
Screens	• Fiberglass • Half screen for left side	• Full screen
Screen Frame Colours	• White	

Architectural detail manual  
Horizontal double slider window DF3304



All vinyl

DF Windows® Collection

Quick SPEC Guide

Specification	Standard features	Optional features Some options may require additional lead times. Consult your JELD-WEN Sales Representative.		
Grilles		<ul style="list-style-type: none"> <li>• 5/8" white internal Georgian (grilles between the glass)</li> <li>• 7/8" SDL (simulated divided lite) with or without spacer bar</li> </ul> <table style="width: 100%; border: none;"> <tr> <td style="vertical-align: top; width: 50%;"> <b>Georgian</b>                      5/8" Light oak/White                      5/8" Dark oak/White                      5/8" Amber oak/White                      5/8" Cherry/White                      5/8" Black/White                      5/8" Ivory/White                      5/8" Wicker/White                      5/8" Sablon/White                      5/8" Clay                      5/8" Clay/White                      5/8" Brown/White                      5/8" Commercial brown/White                      5/8" Brass                      1" White                 </td> <td style="vertical-align: top; width: 50%;"> <b>Pencil Bar</b>                      White                      Brass                      Grey                      Pewter   <b>Square</b>                      Black                      Pewter                      White                      Brass   <b>Flat</b>                      5/8" Ivory/White                      5/8" White                      5/8" Clay/White                      5/8" Clay                      1" White                 </td> </tr> </table>	<b>Georgian</b> 5/8" Light oak/White 5/8" Dark oak/White 5/8" Amber oak/White 5/8" Cherry/White 5/8" Black/White 5/8" Ivory/White 5/8" Wicker/White 5/8" Sablon/White 5/8" Clay 5/8" Clay/White 5/8" Brown/White 5/8" Commercial brown/White 5/8" Brass 1" White	<b>Pencil Bar</b> White Brass Grey Pewter  <b>Square</b> Black Pewter White Brass  <b>Flat</b> 5/8" Ivory/White 5/8" White 5/8" Clay/White 5/8" Clay 1" White
<b>Georgian</b> 5/8" Light oak/White 5/8" Dark oak/White 5/8" Amber oak/White 5/8" Cherry/White 5/8" Black/White 5/8" Ivory/White 5/8" Wicker/White 5/8" Sablon/White 5/8" Clay 5/8" Clay/White 5/8" Brown/White 5/8" Commercial brown/White 5/8" Brass 1" White	<b>Pencil Bar</b> White Brass Grey Pewter  <b>Square</b> Black Pewter White Brass  <b>Flat</b> 5/8" Ivory/White 5/8" White 5/8" Clay/White 5/8" Clay 1" White			
Jamb Depth	<ul style="list-style-type: none"> <li>• 3 1/4"</li> </ul>	<ul style="list-style-type: none"> <li>• Closed interior frame</li> <li>• Vinyl clad interior jamb extension up to 8 7/8"</li> <li>• Natural interior jamb extension up to 4 3/4" clear or finger jointed pine</li> </ul>		

All vinyl

### General Information

#### MULTIPLE ASSEMBLIES

Vinyl Horizontal slider may be mullied above, below, or beside other vinyl windows, operating or fixed as "Single" slide only. Factory assembled mulls are limited in height (99"), width (150"), and a total area (60 square feet).

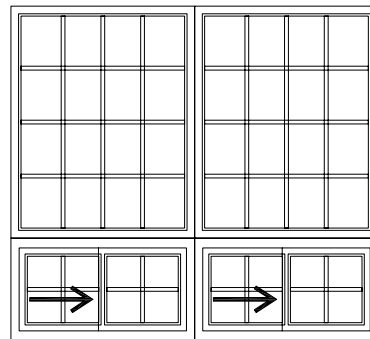
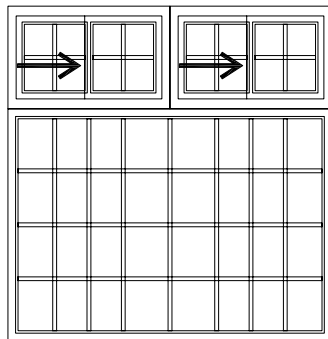
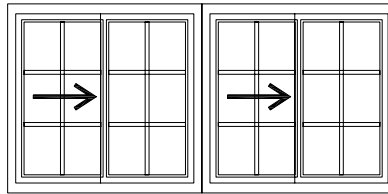

# Architectural detail manual

## Horizontal double slider window DF3304

All vinyl

### EZ Spec Guide

ELEVATION DRAWINGS UTILIZE A LIMITED NUMBER OF PROJECTED LINES TO PRODUCE A RUDIMENTARY DRAWING INTENDED TO BE USED IN A SMALL GRAPHICAL SCALE. ELEVATIONS ARE VIEWED PERPENDICULAR FROM THE EXTERIOR OF THE STRUCTURE. IF MORE DIMENSIONS ARE NEEDED, USE THE SECTION DRAWINGS FOR MORE COMPLETE DEPICTIONS.

#### Height

Rough Opening	35 3/4" - 908mm
Frame Size	35" - 889mm
Glass Size	28 1/8" - 714mm

#### Width

Rough Opening	42 3/4" - 1086mm
Frame Size	42" - 1067mm
Glass Size	17 1/8" - 435mm

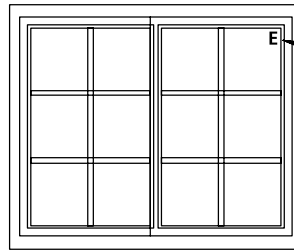

WINDOWS MEETS EGRESS AS PER CANADIAN NBC

OUTSIDE OF FRAME

VCA1T042035

BOOK CODE

'VCA' INDICATES ALL VINYL HORIZONTAL SLIDER DF3304

THE NUMBER INDICATES THE NUMBER OF UNITS MULLED TOGETHER

'T' INDICATES DUAL GLAZED PRODUCT

THE NEXT THREE NUMBERS INDICATE THE UNIT HEIGHT IN INCHES

THE FIRST THREE NUMBERS INDICATE THE UNIT WIDTH IN INCHES

#### GENERAL SLIDER NOTES

3. UNIT ELEVATIONS ARE SHOWN WITHOUT EXTERIOR TRIM.

#### ELEVATION SYMBOL LEGEND:

**E** BASIC UNIT CLEAR OPENING EXCEEDS 15" IN WIDTH, 15" IN HEIGHT & A MINIMUM OF 3.77 SQ. FT. UNOBSTRUCTED OPENING BASED ON CANADIAN NBC

#### HORIZONTAL SLIDER COMBINATIONS

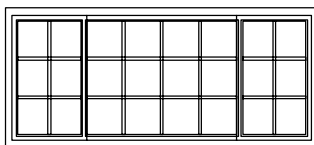

VCA1XT078035

INDICATES IN 3 UNEVEN SECTIONS

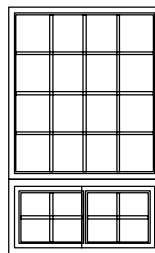

VCA1CT038062

INDICATES PICTURE OVER SLIDER

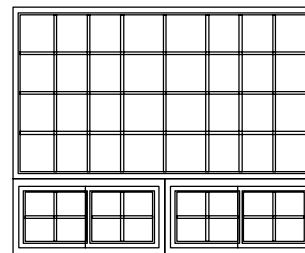

VCA2CT076062

INDICATES PICTURE OVER 2 SLIDER WINDOWS

# Architectural detail manual

## Horizontal double slider window DF3304

All vinyl

DF Windows® Collection

Dim. Col.  
CADRE  
FRAME  
VERRE  
GLASS

15 3/4"•400mm 15"•453mm 8 1/8"•206mm	26 3/4"•679mm 25"•630mm 9 1/8"•232mm	30 3/4"•781mm 30"•762mm 11 1/8"•283mm	34 3/4"•893mm 34"•854mm 13 1/8"•333mm	36 3/4"•933mm 36"•914mm 14 1/8"•359mm	38 3/4"•984mm 38"•955mm 15 1/8"•384mm	42 3/4"•1086mm 42"•1057mm 17 1/8"•435mm	46 3/4"•1187mm 46"•1168mm 19 1/8"•486mm
VCA1T026015	VCA1T030015	VCA1T034015	VCA1T036015	VCA1T038015	VCA1T042015	VCA1T046015	
VCA1T026019	VCA1T030019	VCA1T034019	VCA1T036019	VCA1T038019	VCA1T042019	VCA1T046019	
VCA1T026023	VCA1T030023	VCA1T034023	VCA1T036023	VCA1T038023	VCA1T042023	VCA1T046023	
VCA1T026027	VCA1T030027	VCA1T034027	VCA1T036027	VCA1T038027	VCA1T042027	VCA1T046027	
VCA1T026031	VCA1T030031	VCA1T034031	VCA1T036031	VCA1T038031	VCA1T042031	VCA1T046031	
VCA1T026035	VCA1T030035	VCA1T034035	VCA1T036035	VCA1T038035	VCA1T042035	VCA1T046035	
VCA1T026039	VCA1T030039	VCA1T034039	VCA1T036039	VCA1T038039	VCA1T042039	VCA1T046039	
VCA1T026043	VCA1T030043	VCA1T034043	VCA1T036043	VCA1T038043	VCA1T042043	VCA1T046043	
VCA1T026048	VCA1T030048	VCA1T034048	VCA1T036048	VCA1T038048	VCA1T042048	VCA1T046048	

# Architectural detail manual

## Horizontal double slider window DF3304

All vinyl

Dim.Col.  
RSC  
FRAIE  
VERRE

15 3/4"•400mm  
15"•381mm  
8 1/8"•206mm

19 3/4"•502mm  
19"•483mm  
12 1/8"•308mm

23 3/4"•603mm  
23"•584mm  
16 1/8"•410mm

27 3/4"•705mm  
27"•686mm  
20 1/8"•511mm

31 3/4"•806mm  
31"•787mm  
24 1/8"•613mm

35 3/4"•908mm  
35"•889mm  
28 1/8"•714mm

39 3/4"•1010mm  
39"•991mm  
32 1/8"•816mm

43 3/4"•1111mm  
43"•1092mm  
36 1/8"•918mm

48 3/4"•1238mm  
48"•1219mm  
41 1/8"•1048mm

48 3/4"•1238mm  
48"•1219mm  
20 1/8"•511mm

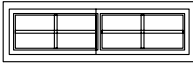

VCA1T048015

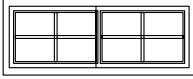

VCA1T048019

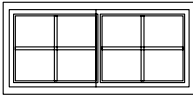

VCA1T048023

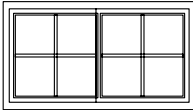

VCA1T048027

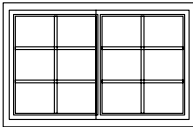

VCA1T048031

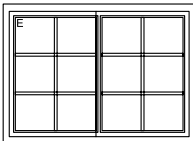

VCA1T048035

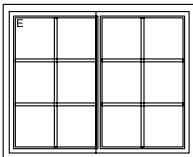

VCA1T048039

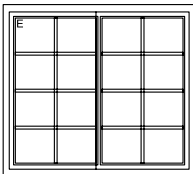

VCA1T048043

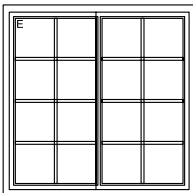

VCA1T048048

50 3/4"•1289mm  
50"•1270mm  
21 1/8"•537mm

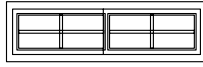

VCA1T050015

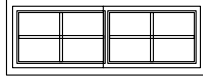

VCA1T050019

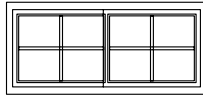

VCA1T050023

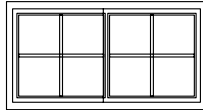

VCA1T050027

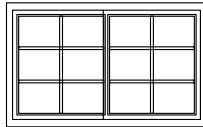

VCA1T050031

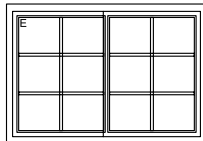

VCA1T050035

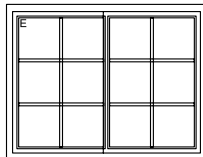

VCA1T050039

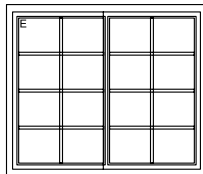

VCA1T050043

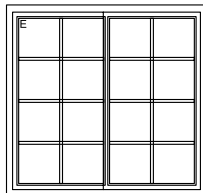

VCA1T050048

54 3/4"•1391mm  
54"•1372mm  
23 1/8"•587mm

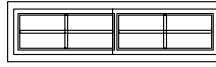

VCA1T054015

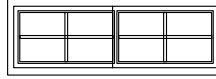

VCA1T054019

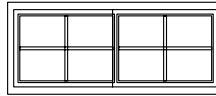

VCA1T054023

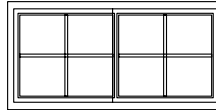

VCA1T054027

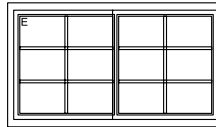

VCA1T054031

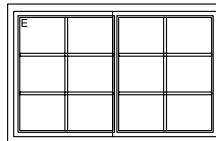

VCA1T054035

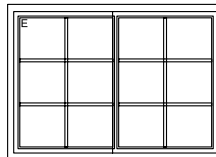

VCA1T054039

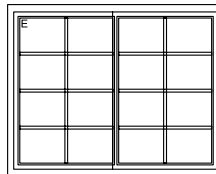

VCA1T054043

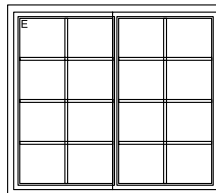

VCA1T054048

58 3/4"•1492mm  
58"•1473mm  
25 1/8"•638mm

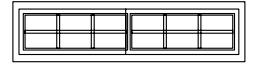

VCA1T058015

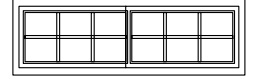

VCA1T058019

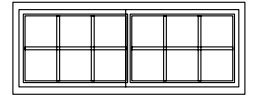

VCA1T058023

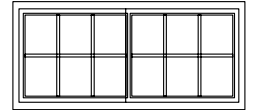

VCA1T058027

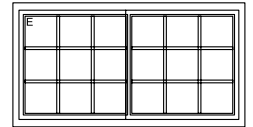

VCA1T058031

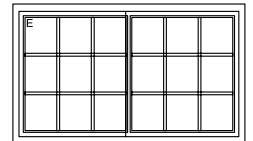

VCA1T058035

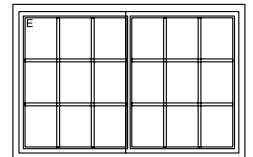

VCA1T058039

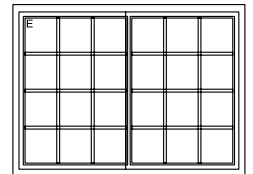

VCA1T058043

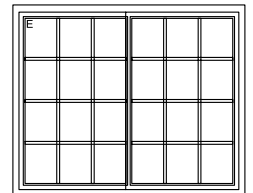

VCA1T058048

# Architectural detail manual

## Horizontal double slider window DF3304

All vinyl

Dim. Col.  
RSO  
CADRE  
FRAME  
GLASS  
VERRE

15 3/4" • 400mm  
15" • 381mm  
8 1/8" • 206mm

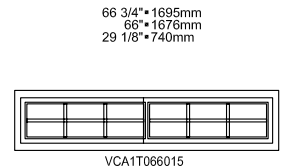
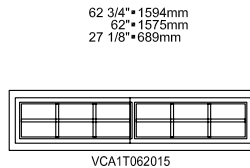
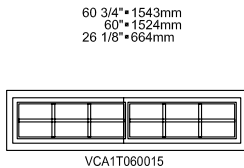

19 3/4" • 502mm  
19" • 483mm  
12 1/8" • 308mm

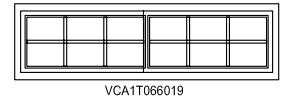
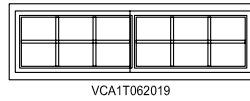
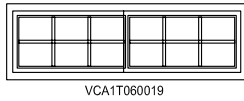

23 3/4" • 603mm  
23" • 584mm  
16 1/8" • 410mm

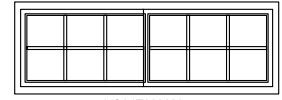
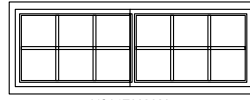
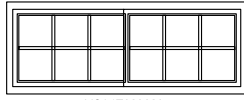

27 3/4" • 705mm  
27" • 686mm  
20 1/8" • 511mm

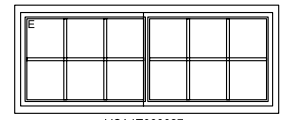
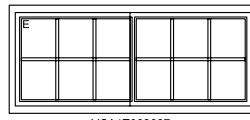
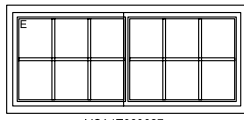

31 3/4" • 806mm  
31" • 787mm  
24 1/8" • 613mm

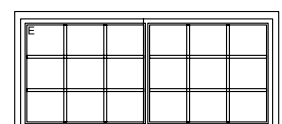
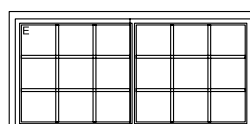
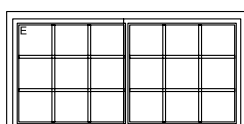

35 3/4" • 908mm  
35" • 889mm  
28 1/8" • 714mm

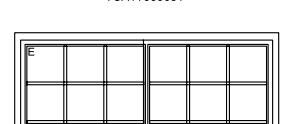
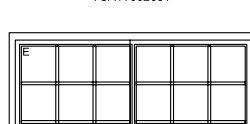

39 3/4" • 1010mm  
39" • 991mm  
32 1/8" • 816mm

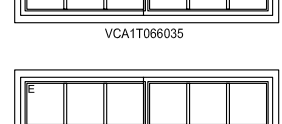
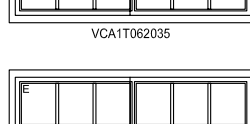
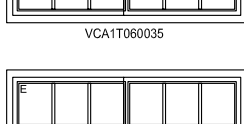

43 3/4" • 1111mm  
43" • 1092mm  
36 1/8" • 918mm

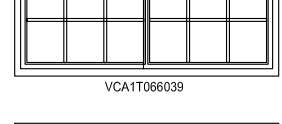
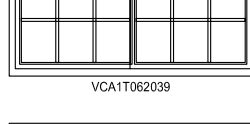
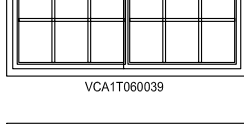

48 3/4" • 1238mm  
48" • 1219mm  
41 1/8" • 1045mm

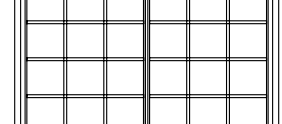
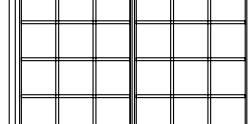
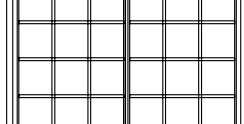



# Architectural detail manual

## Horizontal double slider window DF3304

All vinyl

Dim.Col.  
CADRE  
FRAME  
FRAME  
VERRE  
GLASS

15 3/4"•400mm  
15"•381mm  
8 1/8"•206mm

19 3/4"•502mm  
19"•483mm  
12 1/8"•308mm

23 3/4"•603mm  
23"•584mm  
16 1/8"•410mm

27 3/4"•705mm  
27"•686mm  
20 1/8"•511mm

31 3/4"•806mm  
31"•787mm  
24 1/8"•613mm

35 3/4"•908mm  
35"•889mm  
28 1/8"•714mm

39 3/4"•1010mm  
39"•991mm  
32 1/8"•816mm

43 3/4"•1111mm  
43"•1092mm  
36 1/8"•918mm

48 3/4"•1238mm  
48"•1219mm  
41 1/8"•1045mm

70 3/4"•1797mm  
70"•1778mm  
31 1/8"•791mm

72 3/4"•1848mm  
72"•1829mm  
32 1/8"•816mm

74 3/4"•1899mm  
74"•1880mm  
33 1/8"•841mm



VCA1T070015



VCA1T072015



VCA1T074015

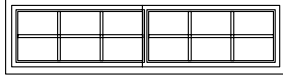

VCA1T070019

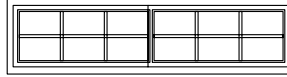

VCA1T072019

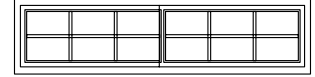

VCA1T074019

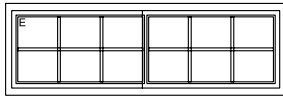

VCA1T070023

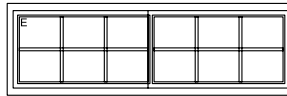

VCA1T072023

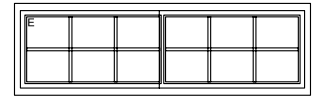

VCA1T074023

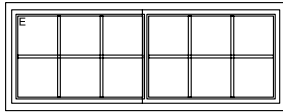

VCA1T070027

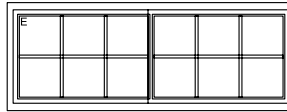

VCA1T072027

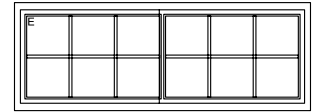

VCA1T074027

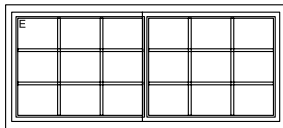

VCA1T070031

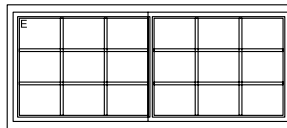

VCA1T072031

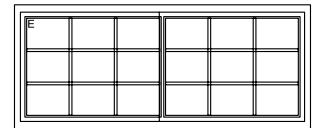

VCA1T074031

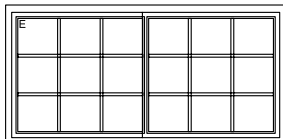

VCA1T070035

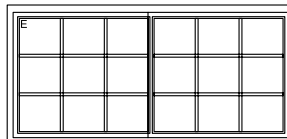

VCA1T072035

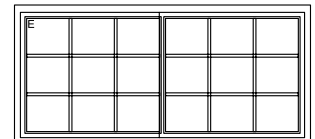

VCA1T074035

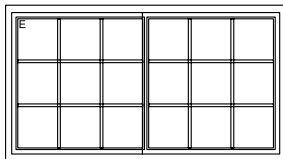

VCA1T070039

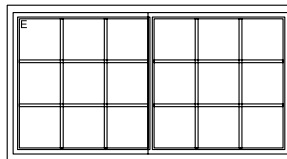

VCA1T072039

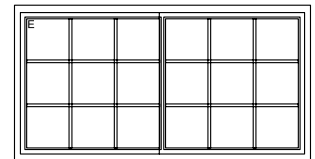

VCA1T074039

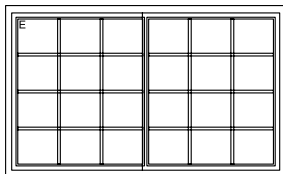

VCA1T070043

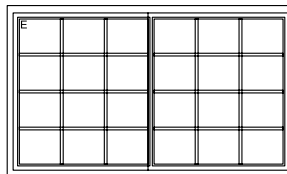

VCA1T072043

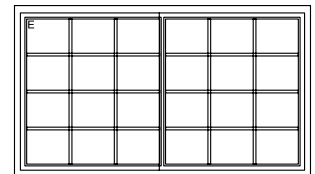

VCA1T074043

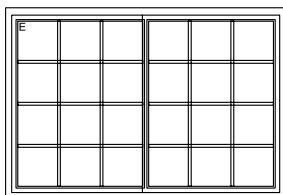

VCA1T070048

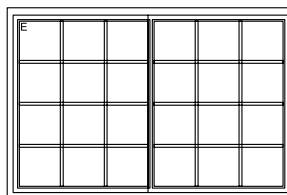

VCA1T072048

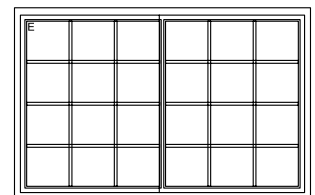

VCA1T074048

# Architectural detail manual

## Horizontal double slider window DF3304

All vinyl

Dim. Col.  
RSC CADRE  
FRAME  
GLASS VERRE

78 3/4" • 2000mm  
78" • 1981mm  
15 3/4" • 37 3/8" • 15 3/4"  
400mm • 949mm • 400mm

86 3/4" • 2203mm  
86" • 2184mm  
17 3/4" • 41 3/8" • 17 3/4"  
451mm • 1051mm • 451mm

94 3/4" • 2407mm  
94" • 2388mm  
19 3/4" • 45 3/8" • 19 3/4"  
502mm • 1153mm • 502mm

15 3/4" • 400mm  
15" • 381mm  
8 1/8" • 206mm

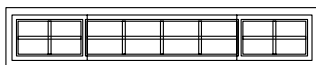

VCA1XT078015

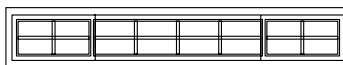

VCA1XT086015

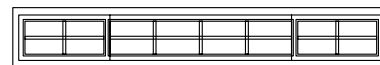

VCA1XT094015

19 3/4" • 502mm  
19" • 483mm  
12 1/8" • 308mm

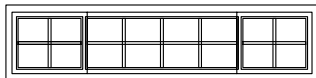

VCA1XT078019

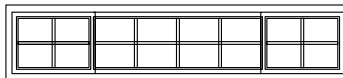

VCA1XT086019

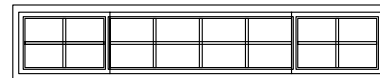

VCA1XT094019

23 3/4" • 603mm  
23" • 584mm  
16 1/8" • 410mm

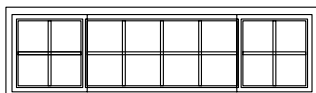

VCA1XT078023

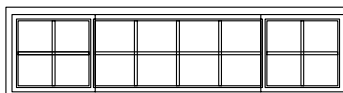

VCA1XT086023

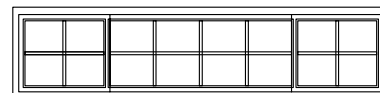

VCA1XT094023

27 3/4" • 705mm  
27" • 686mm  
20 1/8" • 511mm

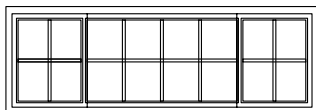

VCA1XT078027

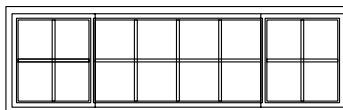

VCA1XT086027

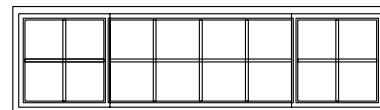

VCA1XT094027

31 3/4" • 806mm  
31" • 787mm  
24 1/8" • 613mm

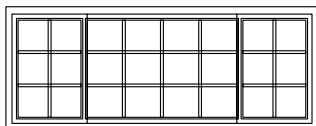

VCA1XT078031

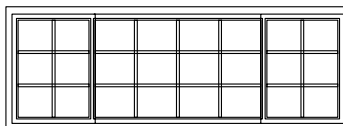

VCA1XT086031

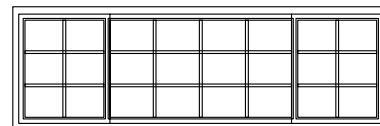

VCA1XT094031

35 3/4" • 908mm  
35" • 889mm  
28 1/8" • 714mm

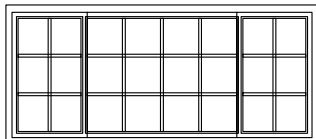

VCA1XT078035

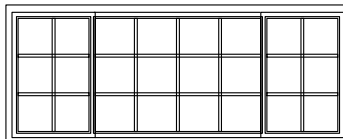

VCA1XT086035

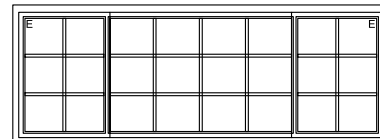

VCA1XT094035

39 3/4" • 1010mm  
39" • 991mm  
32 1/8" • 816mm

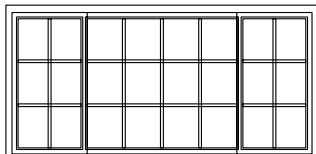

VCA1XT078039

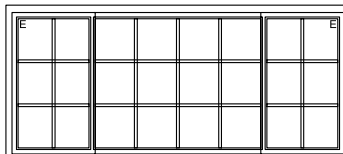

VCA1XT086039

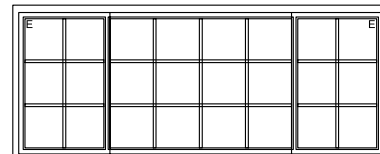

VCA1XT094039

43 3/4" • 1111mm  
43" • 1092mm  
36 1/8" • 916mm

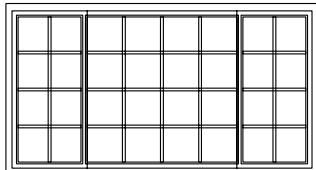

VCA1XT078043

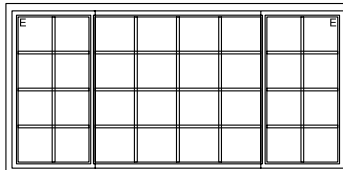

VCA1XT086043

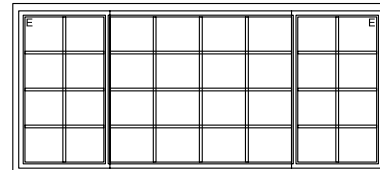

VCA1XT094043

48 3/4" • 1238mm  
48" • 1219mm  
41 1/8" • 1045mm

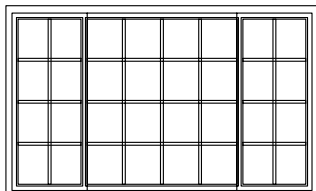

VCA1XT078048

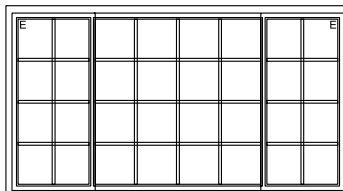

VCA1XT086048

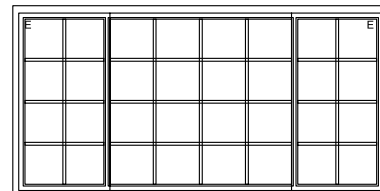

VCA1XT094048

# Architectural detail manual

## Horizontal double slider window DF3304

All vinyl

DF Windows® Collection

Dim.Col.  
RSO  
FRAIS CADRE  
GLASS VERRE

26 3/4"•679mm  
26"•660mm  
9 1/8"•232mm  
22 1/4"•565mm

30 3/4"•781mm  
30"•762mm  
11 1/8"•283mm  
26 1/4"•667mm

34 3/4"•883mm  
34"•864mm  
13 1/8"•333mm  
30 1/4"•768mm

38 3/4"•984mm  
38"•965mm  
15 1/8"•394mm  
34 1/4"•870mm

42 3/4"•1086mm  
42"•1067mm  
17 1/8"•435mm  
38 1/4"•972mm

46 3/4"•1187mm  
46"•1168mm  
19 1/8"•488mm  
42 1/4"•1073mm

54 3/4"•1391mm  
54"•1372mm  
12 1/8"•308mm \*\* 31 1/4"•794mm

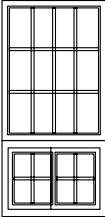

VCA1CT026054

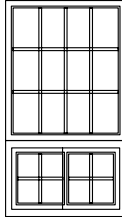

VCA1CT030054

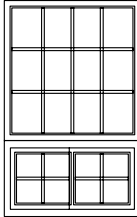

VCA1CT034054

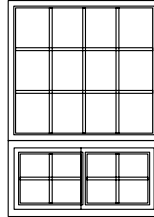

VCA1CT038054

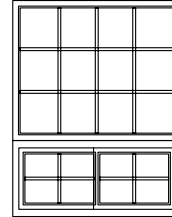

VCA1CT042054

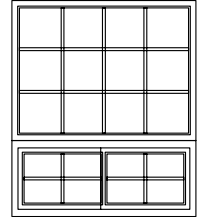

VCA1CT046054

62 3/4"•1594mm  
62"•1575mm  
12 1/8"•308mm \*\* 38 1/4"•997mm

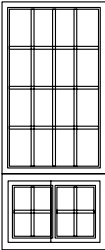

VCA1CT026062

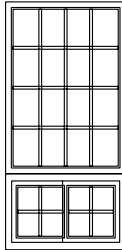

VCA1CT030062

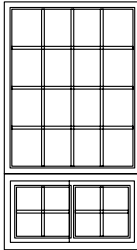

VCA1CT034062

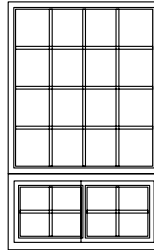

VCA1CT038062

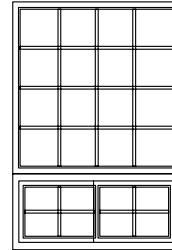

VCA1CT042062

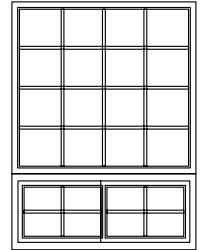

VCA1CT046062

70 3/4"•1797mm  
70"•1778mm  
12 1/8"•308mm \*\* 47 1/4"•1200mm

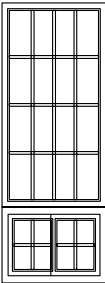

VCA1CT026070

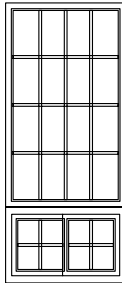

VCA1CT030070

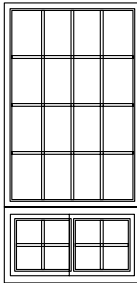

VCA1CT034070

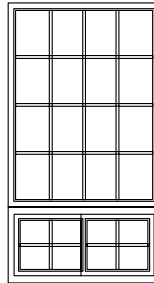

VCA1CT038070

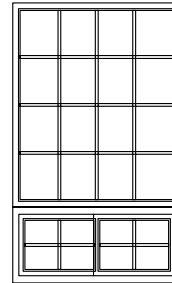

VCA1CT042070

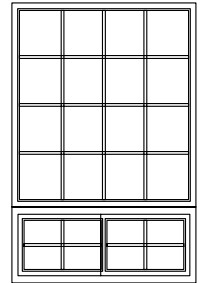

VCA1CT046070

# Architectural detail manual

## Horizontal double slider window DF3304

All vinyl

DF Windows® Collection

Dim.Col.  
RSO CADRE  
FRAME  
GLASS VERRE

50 3/4" • 1289mm  
50" • 1270mm  
21 1/8" • 537mm  
46 1/4" • 1175mm

54 3/4" • 1391mm  
54" • 1372mm  
23 1/8" • 587mm  
50 1/4" • 1276mm

58 3/4" • 1492mm  
58" • 1473mm  
25 1/8" • 639mm  
54 1/4" • 1378mm

54 3/4" • 1391mm  
12 1/8" • 308mm \*\* 31 1/4" • 794mm

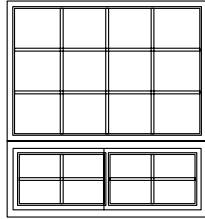

VCA1CT050054

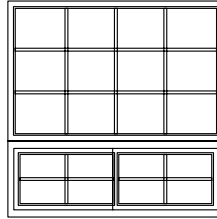

VCA1CT054054

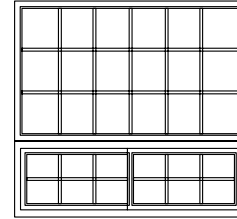

VCA1CT058054

62 3/4" • 1594mm  
12 1/8" • 308mm \*\* 39 1/4" • 997mm

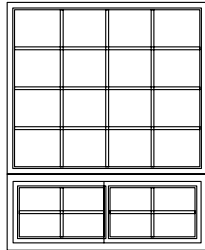

VCA1CT050062

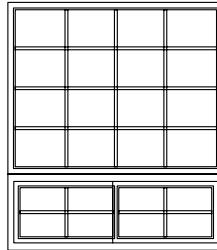

VCA1CT054062

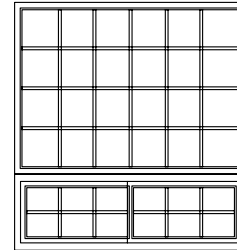

VCA1CT058062

70 3/4" • 1797mm  
12 1/8" • 308mm \*\* 47 1/4" • 1200mm

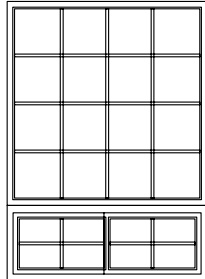

VCA1CT050070

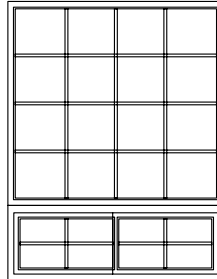

VCA1CT054070

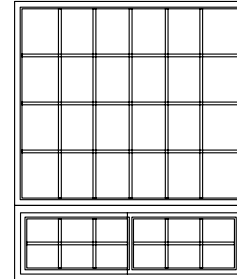

VCA1CT058070

# Architectural detail manual

## Horizontal double slider window DF3304

All vinyl

DF Windows® Collection

Dim. Col.  
RSC  
CADRE  
VERRE  
GLASS

52 3/4" • 1340mm  
52" • 1321mm  
9 1/8" • 232mm \*\* 48 1/4" • 1226mm

60 3/4" • 1543mm  
60" • 1524mm  
11 1/8" • 283mm \*\* 56 1/4" • 1429mm

68 3/4" • 1797mm  
68" • 1727mm  
13 1/8" • 333mm \*\* 64 1/4" • 1632mm

54 3/4" • 1391mm  
54" • 1372mm  
12 1/8" • 308mm \*\* 31 1/4" • 794mm

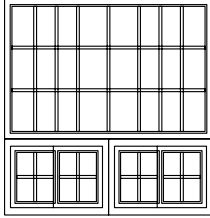

VCA2CT052054

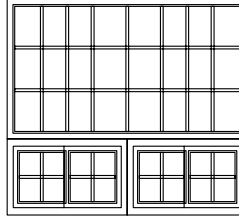

VCA2CT060054

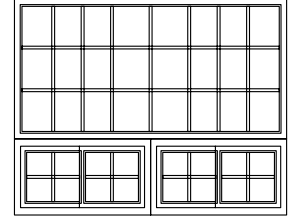

VCA2CT068054

62 3/4" • 1594mm  
62" • 1575mm  
12 1/8" • 308mm \*\* 36 1/4" • 917mm

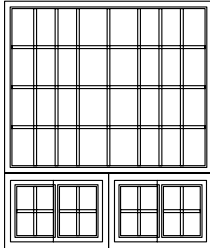

VCA2CT052062

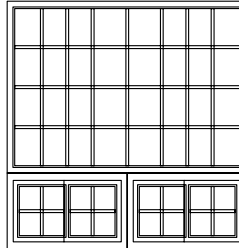

VCA2CT060062

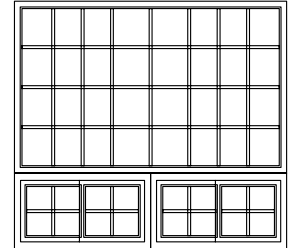

VCA2CT068062

70 3/4" • 1797mm  
70" • 1778mm  
12 1/8" • 308mm \*\* 47 1/4" • 1200mm

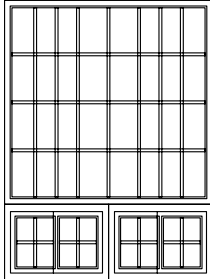

VCA2CT052070

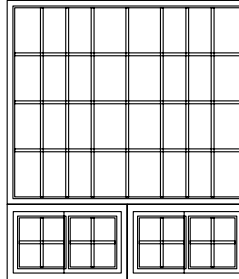

VCA2CT060070

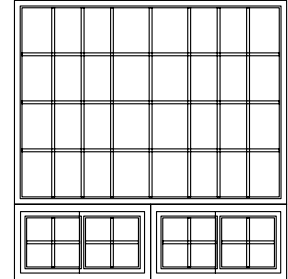

VCA2CT068070

# Architectural detail manual

## Horizontal double slider window DF3304

All vinyl

Dim. Col.  
CADRE  
FRAME  
GLASS  
VERRE

76 3/4"•1949mm  
76"•1930mm  
15 1/8"•384mm \*\* 72 1/4"•1835mm

84 3/4"•2153mm  
84"•2134mm  
17 1/8"•435mm \*\* 80 1/4"•2038mm

92 3/4"•2356mm  
92"•2337mm  
19 1/8"•486mm \*\* 88 1/4"•2242mm

62 3/4"•1594mm  
62"•1575mm  
12 1/8"•308mm \*\* 39 1/4"•997mm

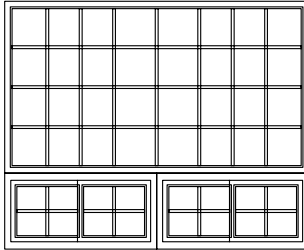

VCA2CT076062

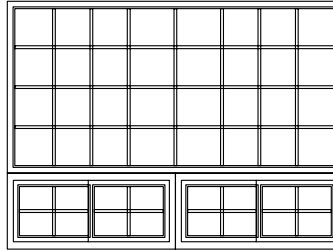

VCA2CT084062

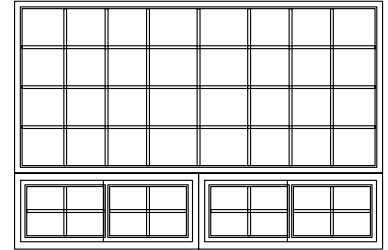

VCA2CT092062

70 3/4"•1797mm  
70"•1778mm  
12 1/8"•308mm \*\* 47 1/4"•1200mm

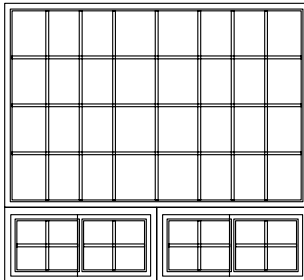

VCA2CT076070

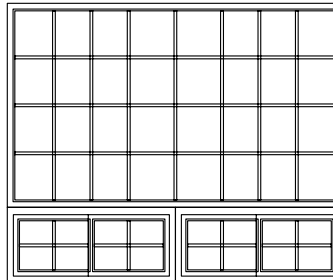

VCA2CT084070

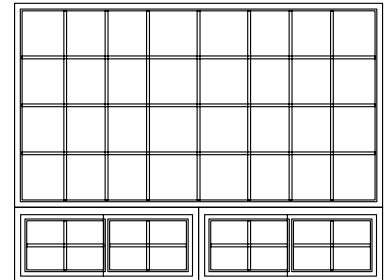

VCA2CT092070

**HORIZONTAL DOUBLE SLIDER GLAZING OPTIONS**

Carrelage scellé  
Internal grilles

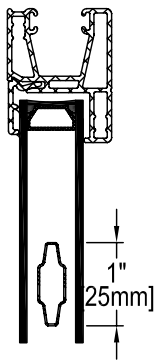

Georgian 1"

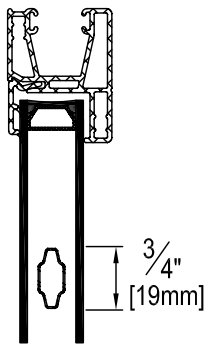

Georgian

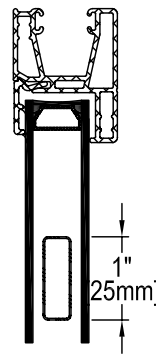

Plat 1"  
1" Flat

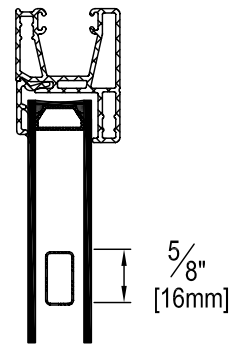

Plat  
Flat

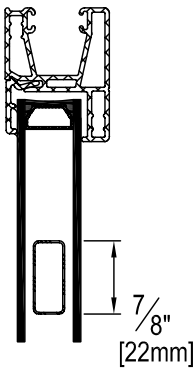

Intercalaire  
Spacer bar

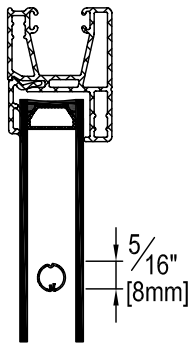

Tubulaire  
Pencil bar

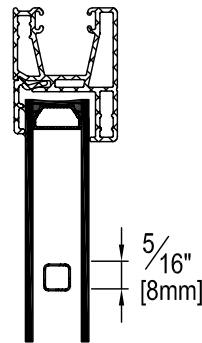

Carré  
Square

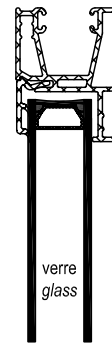

verre  
glass

HORIZONTAL DOUBLE SLIDER GLAZING OPTIONS

Simili barrotin avec intercalaire  
*Simulated divided lite with spacer-bar*

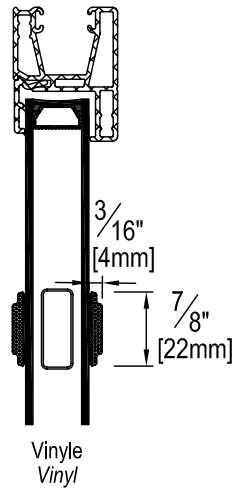

Simili barrotin  
*Simulated divided lite*

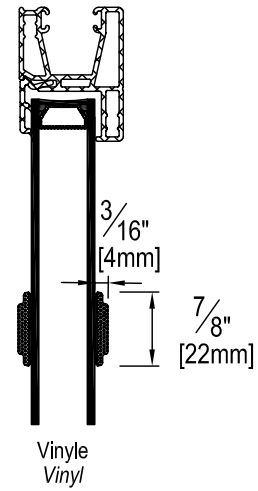



**HORIZONTAL DOUBLE SLIDER TRIM OPTIONS**

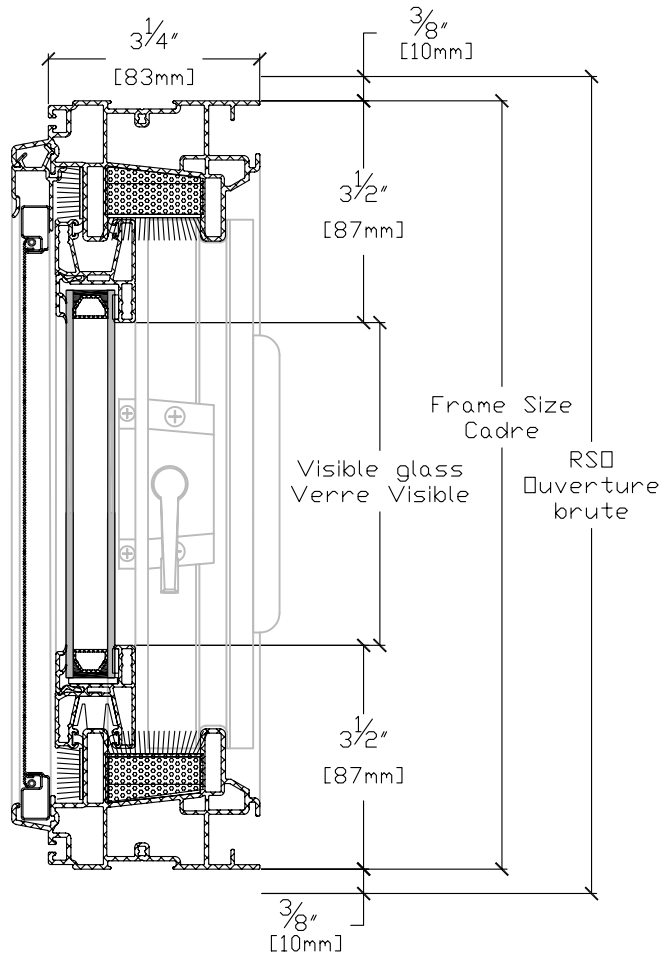

3 1/4" #400  
3 1/4" flush frame #400

**HORIZONTAL DOUBLE SLIDER TRIM OPTIONS**

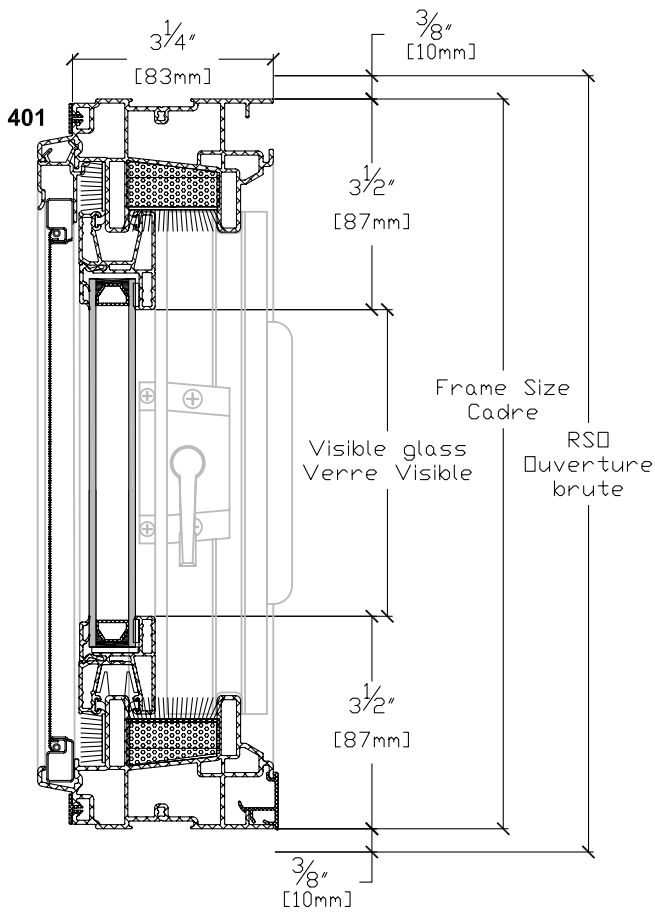

3 1/4" avec 401  
3 1/4" with 401

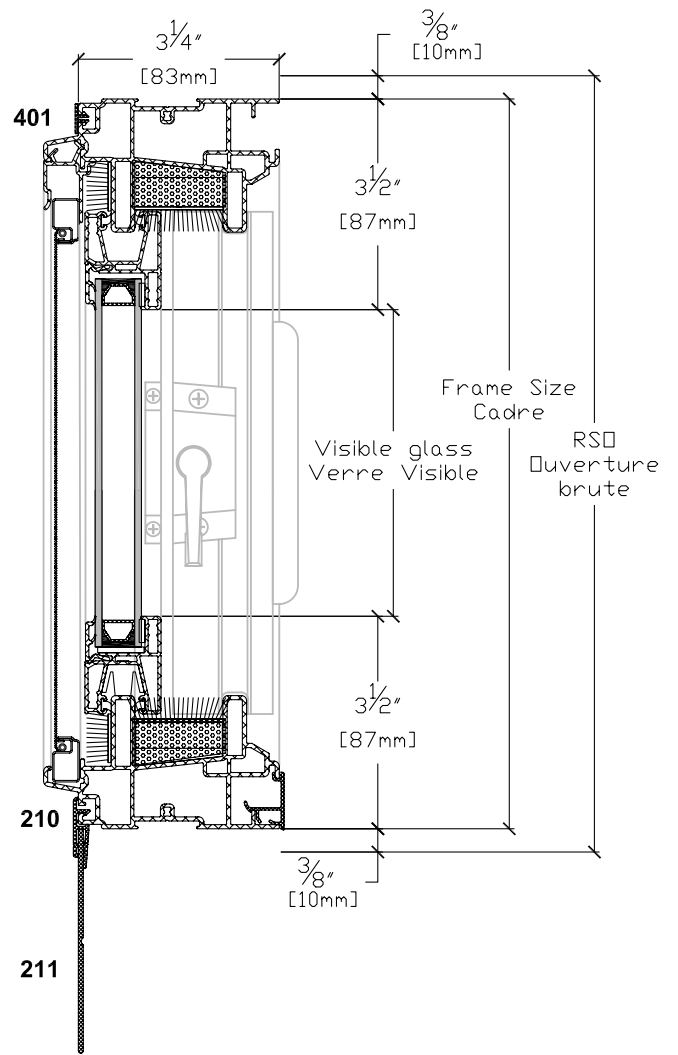

3 1/4" avec 401-210-211  
3 1/4" with 401-210-211

**HORIZONTAL DOUBLE SLIDER TRIM OPTIONS**

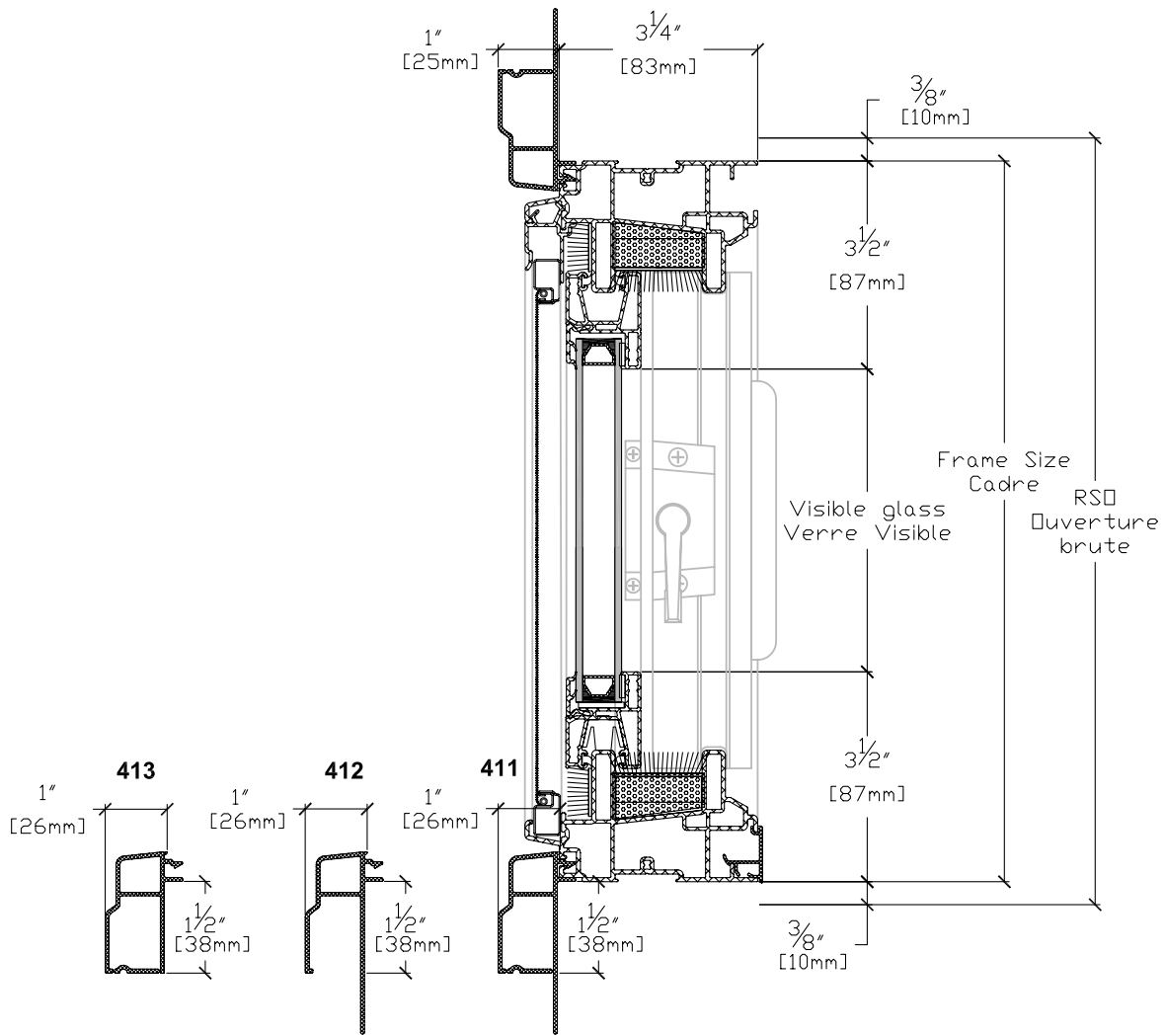

3 1/4" avec 411-412-413  
3 1/4" with 411-412-413

**HORIZONTAL DOUBLE SLIDER TRIM OPTIONS**

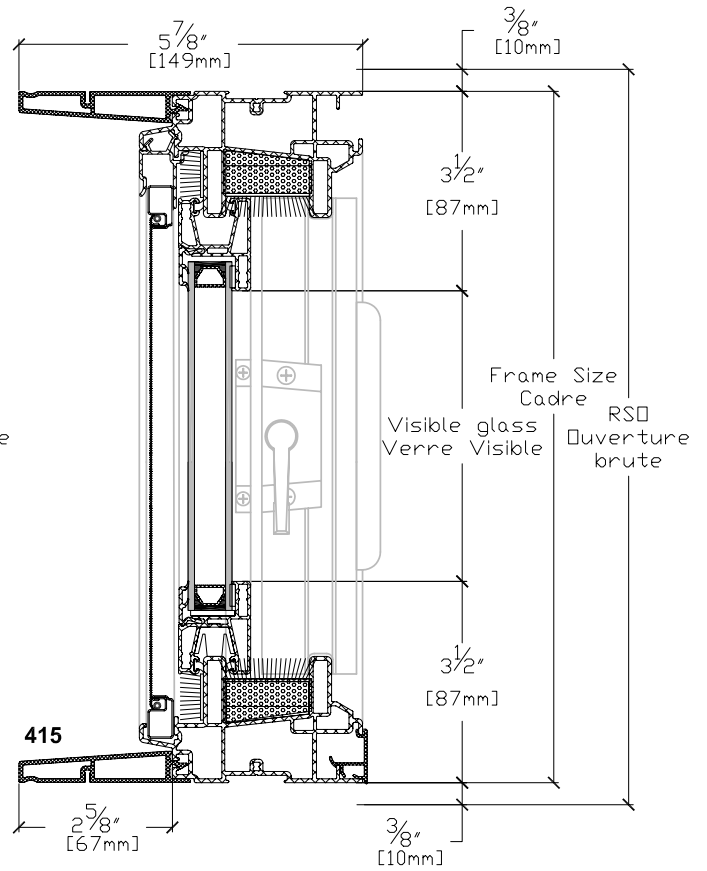
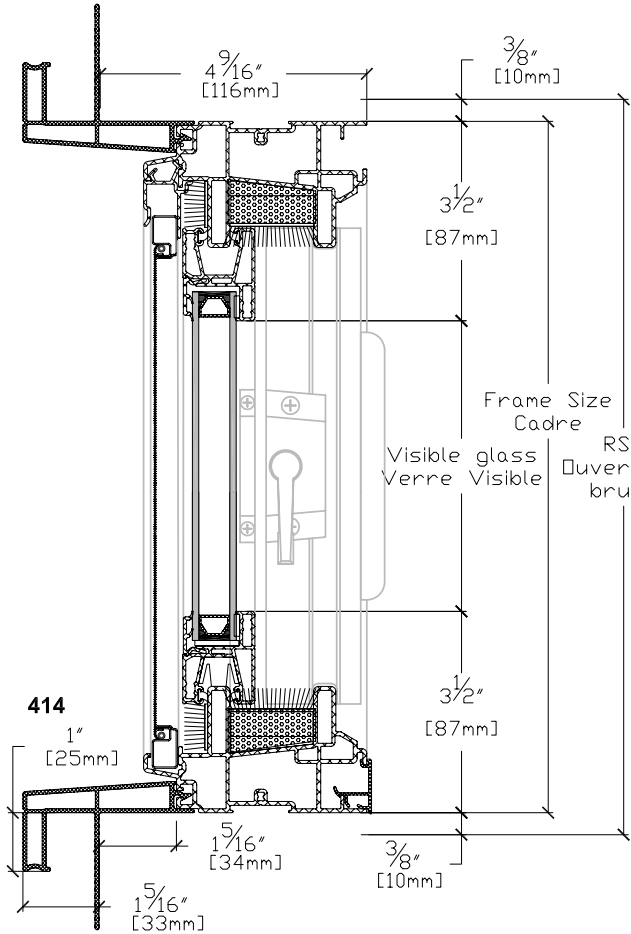

4 9/16" avec 414  
4 9/16" with 414

4 9/16" avec 415  
4 9/16" with 415

**HORIZONTAL DOUBLE SLIDER TRIM OPTIONS**

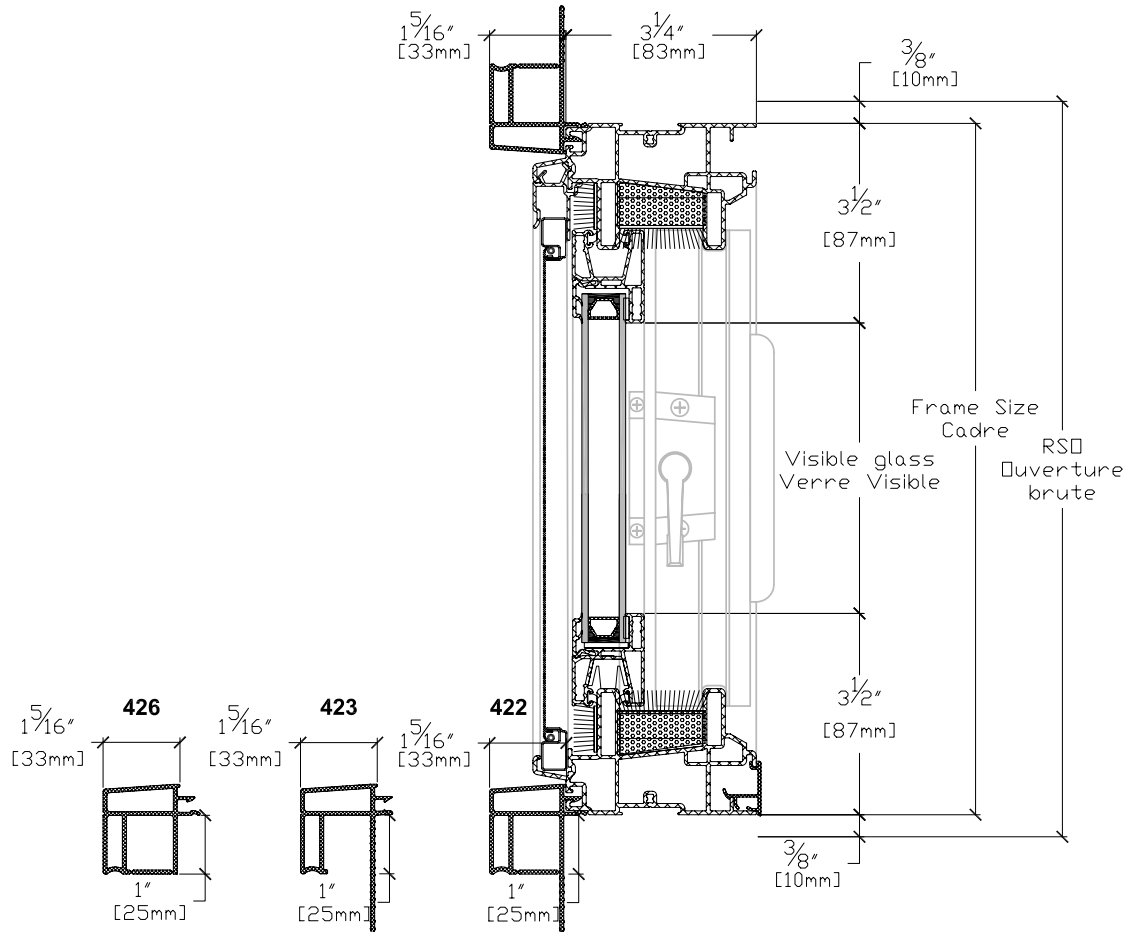

3 1/4" avec 422-423-426

3 1/4" with 422-423-426

**HORIZONTAL DOUBLE SLIDER TRIM OPTIONS**

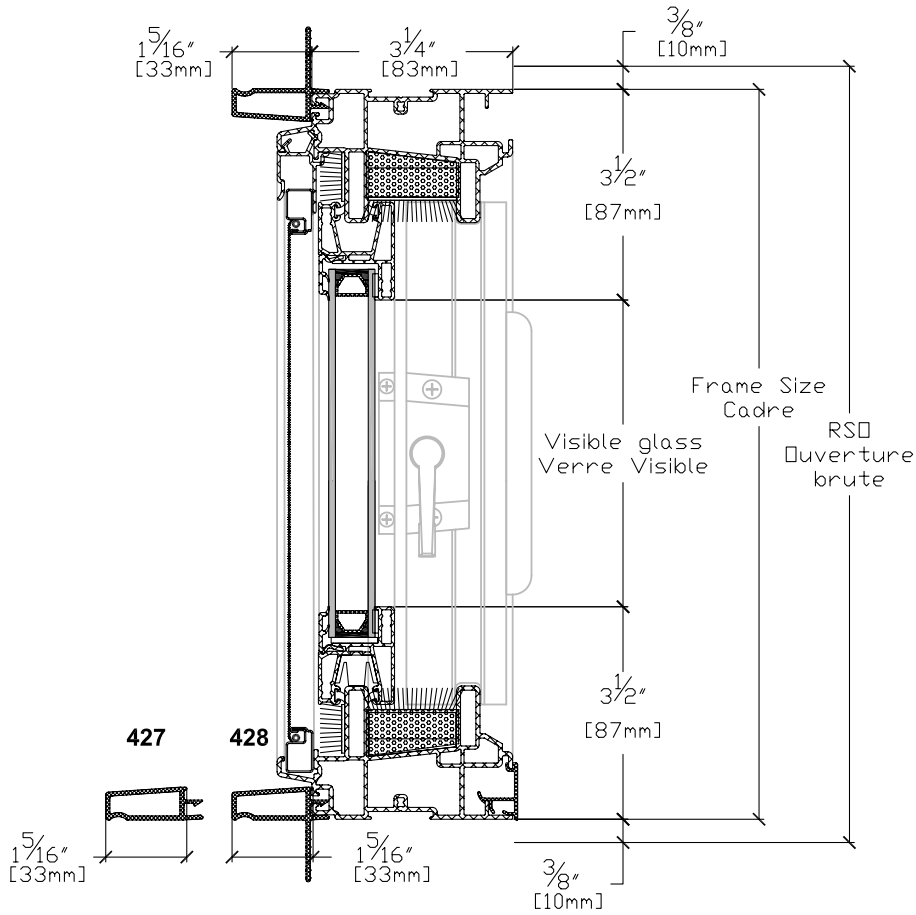

3 1/4" avec 427-428

3 1/4" with 427-428

**HORIZONTAL DOUBLE SLIDER TRIM OPTIONS**

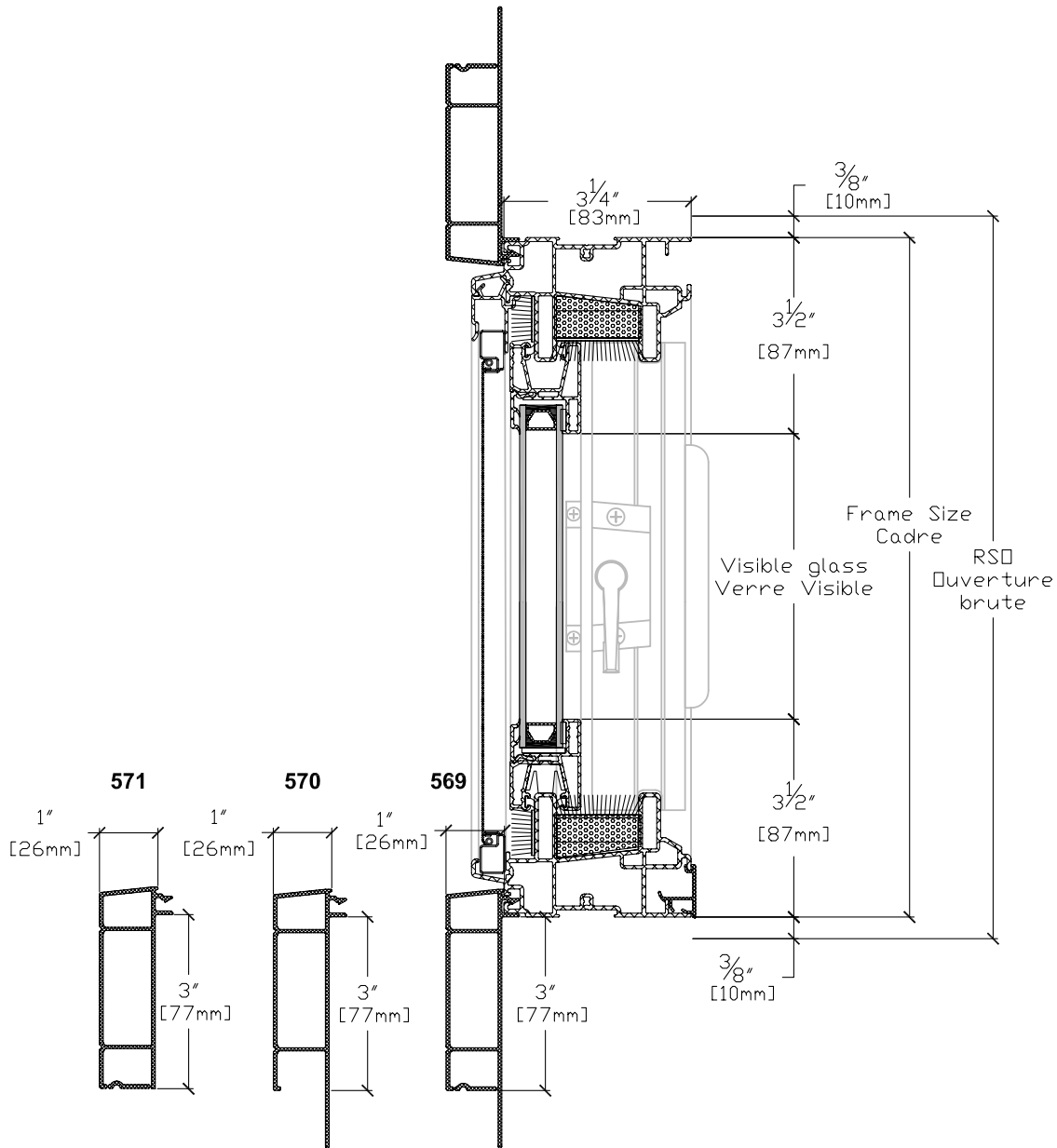

3 1/4" avec 569-570-571  
3 1/4" with 569-570-571

NATURAL JAMB EXTENDER OPTIONS

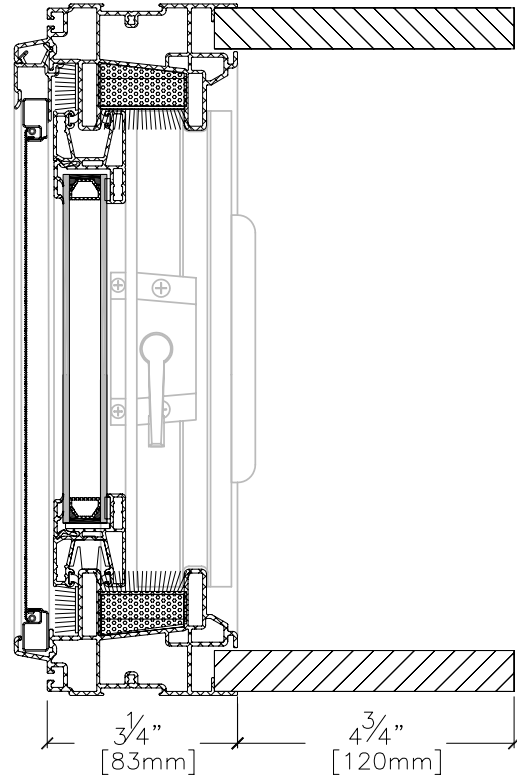
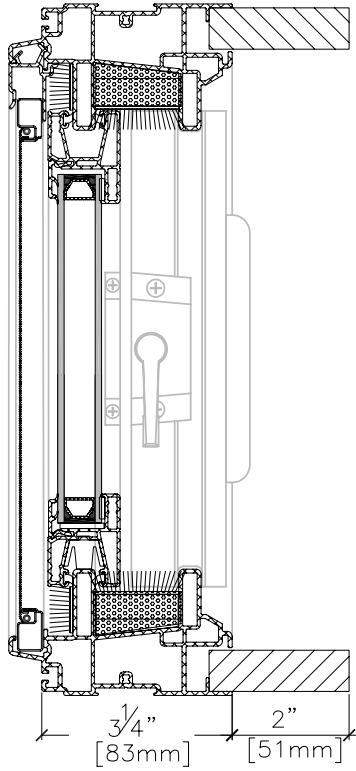



VINYL CLAD JAMB EXTENDER OPTIONS

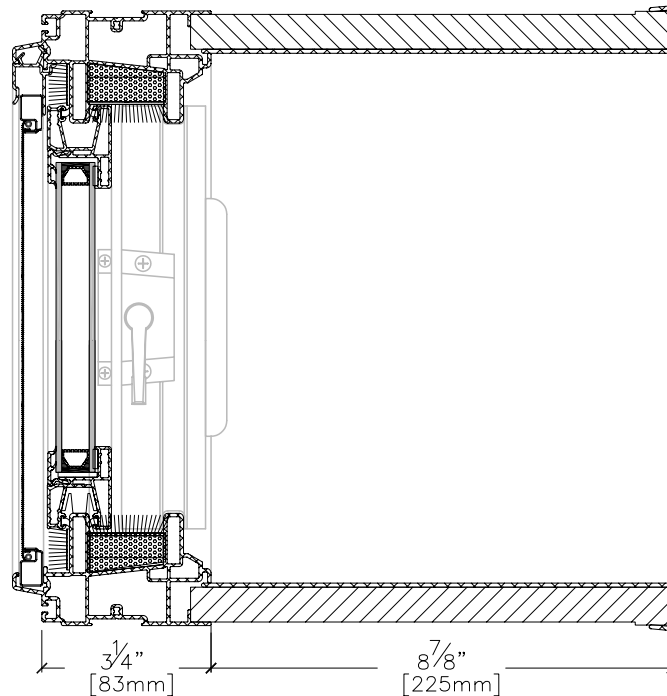
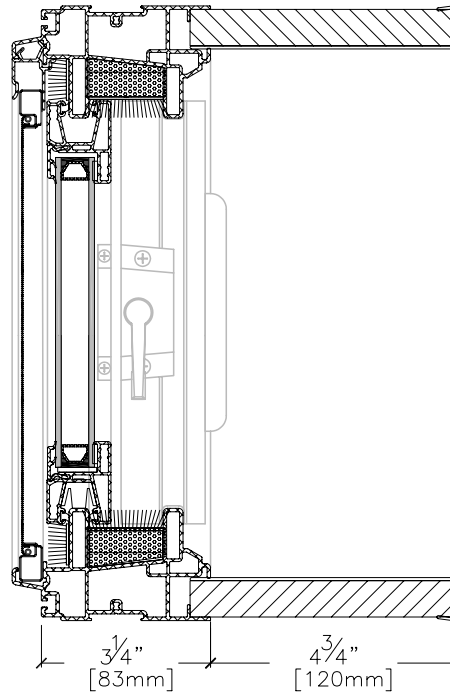
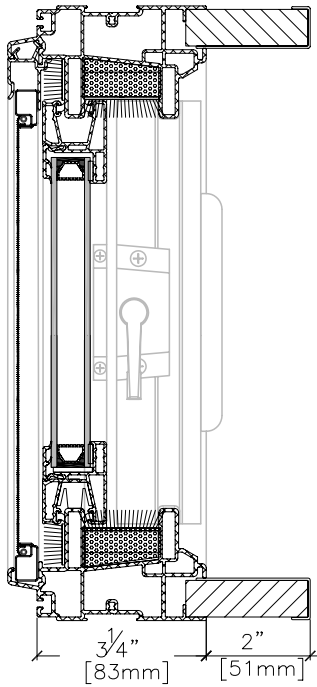

STANDARD MULLION DETAILS

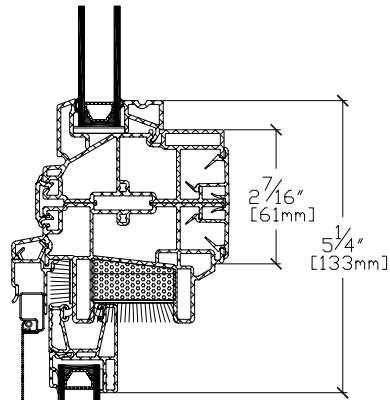

Imposte verre scellé fixe  
Cadre de vinyle  
Transom with fixed lite  
Vinyl frame

OTHER MULLION DETAILS

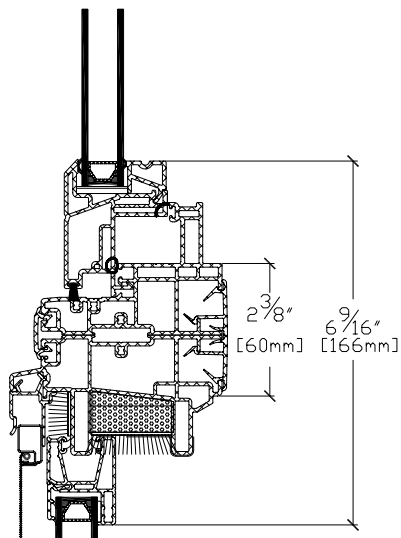

Imposte volet fixe  
Cadre de vinyle  
Transom with fixed sash  
Vinyl frame

## LITE CUT INFORMATION

All vinyl horizontal double slider windows are available with GBG (Grilles between the Glass), and 7/8" Simulated Divided Lites.

### LITE CUT OPTIONS

Special lite cut patterns can include a wide variety of straight line and radius patterns. The illustrations shown here represent just a few of the possibilities. Rectangular, horizontal, vertical and Prairie lite patterns are available in horizontal double slider windows. Uneven, diamond, radius and Gothic lite cuts are available, subject to approval. Approvals are based on the ability to fulfill the design requirement while maintaining the construction integrity of the finished product.

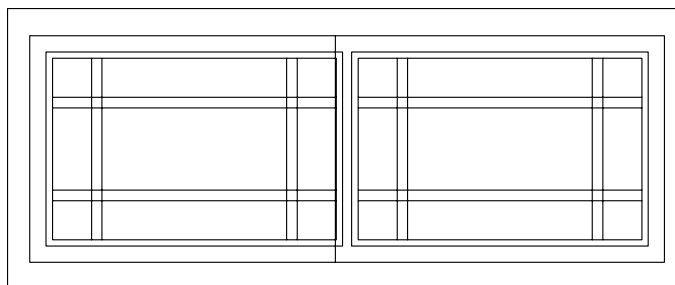

### BAR ALIGNMENT

Alignment of muntin bars from one window to the next is often required by fine architectural design. GBG (Grilles between the Glass), and Simulated Divided Lites may be specified with muntin bars aligned.

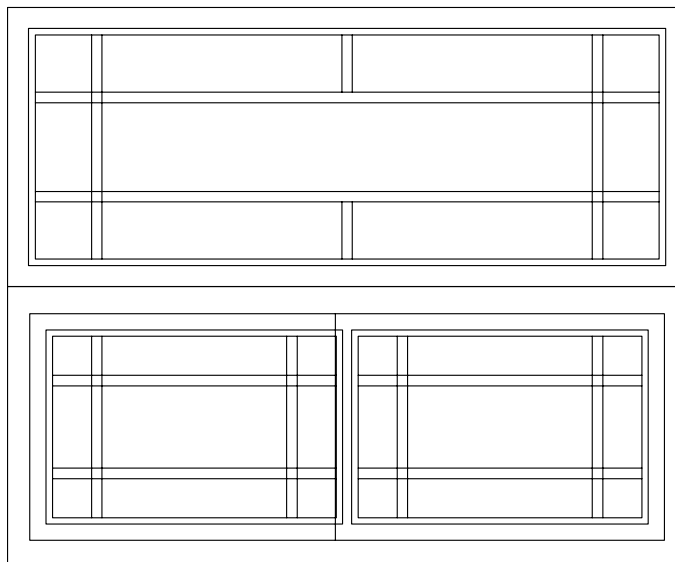

## Combination Assemblies

### Combination Units - All vinyl horizontal double slider

JELD-WEN vinyl horizontal double slider windows can be grouped in almost an infinite number of combinations. They can be mullied directly alongside other operating or fixed windows. Stack them on top or below one another or as part of an elegant Half Round or Quarter Round assembly. Combining them with angular or rectangular Geometrics can create a majestic look. Adding "SDL" (simulated divided lites) or grilles, will accent or provide special effects to your assembly. If standard sizes do not meet your opening requirements, custom sizes may be specified.

Where applications require structural support in the assembly itself, or in the wall section, units may be separated by a specified dimension. If the separation is desired for appearance only, the specified dimension is considered a "spreadmull" and contain filler blocks between the units. In either case, the units are factory assembled and come with exterior and interior mull covers.

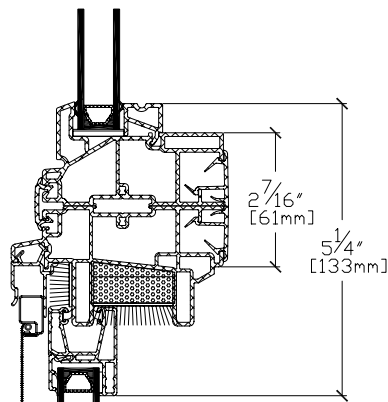

Imposte verre scellé fixe  
Cadre de vinyle  
Transom with fixed lite  
Vinyl frame

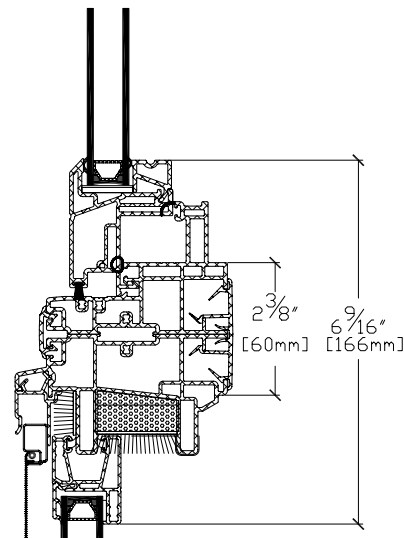

Imposte volet fixe  
Cadre de vinyle  
Transom with fixed sash  
Vinyl frame

#### • How to determine Rough Openings of Multiple Assemblies:

JELD-WEN uses a Rough Opening allowance of 3/4" wider and 3/4" higher than the window assembly. (Contact your Dealer or JELD-WEN for special considerations for angular unit rough openings.)

1. Obtain Frame Dimensions of the units to be mullied.
2. Add Frames together along with any spread mulls.
3. Add 3/4" to the width and 3/4" to the height.

#### • Example:

*R.O. for VCA1T074035 with a fixed lite 15" height stacked above.*

#1: **Width:** The frame width 74"; add 3/4" for R.O. allowance = 74 3/4"

**Height:** Add the frame height 35" to the frame height 15"; add 3/4" for R.O. allowance = 50 3/4"

#2: **Width:** The frame width 74"; add 3/4" for R.O. allowance = 74 3/4"

**Height:** Add the frame height 35" to the frame height 15"; add 1 5/8" for reinforcement; add 3/4" for R.O. allowance = 52 3/8"

# Architectural detail manual

## Horizontal double slider window DF3304



All vinyl

DF Windows® Collection

### Clear Opening and Daylight Specifications DF3304 All vinyl

Unit No.	Clear opening		Clear opening				Daylight Opening		Length of wetherstrip		Unit	
			Width		Height							
	Sq. Ft	Sq. met.	inch	mm	inch	mm	Sq. Ft	Sq. met.	lin. Ft	lin. met.	Sq. Ft	Sq. met.
VCA1T 026 015	0,56	0,05	7,6	194	10,6	270	1,0	0,10	6,6	2,0	2,7	0,25
VCA1T 026 019	0,77	0,07	7,6	194	14,6	371	1,5	0,14	7,6	2,3	3,4	0,32
VCA1T 026 023	0,99	0,09	7,6	194	18,6	473	2,1	0,19	8,6	2,6	4,2	0,39
VCA1T 026 027	1,20	0,11	7,6	194	22,6	575	2,6	0,24	9,6	2,9	4,9	0,45
VCA1T 026 031	1,41	0,13	7,6	194	26,6	676	3,1	0,28	10,6	3,2	5,6	0,52
VCA1T 026 035	1,62	0,15	7,6	194	30,6	778	3,6	0,33	11,6	3,5	6,3	0,59
VCA1T 026 039	1,83	0,17	7,6	194	34,6	879	4,1	0,38	12,6	3,8	7,0	0,65
VCA1T 026 043	2,05	0,19	7,6	194	38,6	981	4,6	0,43	13,6	4,1	7,8	0,72
VCA1T 026 047	2,26	0,21	7,6	194	42,6	1083	5,1	0,47	14,6	4,4	8,5	0,79
VCA1T 030 015	0,71	0,07	9,6	244	10,6	270	1,3	0,12	7,2	2,2	3,1	0,29
VCA1T 030 019	0,98	0,09	9,6	244	14,6	371	1,9	0,17	8,2	2,5	4,0	0,37
VCA1T 030 023	1,24	0,12	9,6	244	18,6	473	2,5	0,23	9,2	2,8	4,8	0,45
VCA1T 030 027	1,51	0,14	9,6	244	22,6	575	3,1	0,29	10,2	3,1	5,6	0,52
VCA1T 030 031	1,78	0,17	9,6	244	26,6	676	3,7	0,35	11,2	3,4	6,5	0,60
VCA1T 030 035	2,05	0,19	9,6	244	30,6	778	4,4	0,40	12,2	3,7	7,3	0,68
VCA1T 030 039	2,31	0,22	9,6	244	34,6	879	5,0	0,46	13,2	4,0	8,1	0,75
VCA1T 030 043	2,58	0,24	9,6	244	38,6	981	5,6	0,52	14,2	4,3	9,0	0,83
VCA1T 030 047	2,85	0,26	9,6	244	42,6	1083	6,2	0,58	15,2	4,6	9,8	0,91
VCA1T 034 015	0,86	0,08	11,6	295	10,6	270	1,5	0,14	7,9	2,4	3,5	0,33
VCA1T 034 019	1,18	0,11	11,6	295	14,6	371	2,2	0,21	8,9	2,7	4,5	0,42
VCA1T 034 023	1,50	0,14	11,6	295	18,6	473	2,9	0,27	9,9	3,0	5,4	0,50
VCA1T 034 027	1,83	0,17	11,6	295	22,6	575	3,7	0,34	10,9	3,3	6,4	0,59
VCA1T 034 031	2,15	0,20	11,6	295	26,6	676	4,4	0,41	11,9	3,6	7,3	0,68
VCA1T 034 035	2,47	0,23	11,6	295	30,6	778	5,1	0,48	12,9	3,9	8,3	0,77
VCA1T 034 039	2,80	0,26	11,6	295	34,6	879	5,9	0,55	13,9	4,2	9,2	0,86
VCA1T 034 043	3,12	0,29	11,6	295	38,6	981	6,6	0,61	14,9	4,5	10,2	0,94
VCA1T 034 047	3,44	0,32	11,6	295	42,6	1083	7,3	0,68	15,9	4,8	11,1	1,03
VCA1T 036 015	0,93	0,09	12,6	321	10,6	270	1,6	0,15	8,2	2,5	3,8	0,35
VCA1T 036 019	1,28	0,12	12,6	321	14,6	371	2,4	0,22	9,2	2,8	4,8	0,44
VCA1T 036 023	1,63	0,15	12,6	321	18,6	473	3,2	0,29	10,2	3,1	5,8	0,53
VCA1T 036 027	1,98	0,18	12,6	321	22,6	575	4,0	0,37	11,2	3,4	6,8	0,63
VCA1T 036 031	2,33	0,22	12,6	321	26,6	676	4,7	0,44	12,2	3,7	7,8	0,72
VCA1T 036 035	2,69	0,25	12,6	321	30,6	778	5,5	0,51	13,2	4,0	8,8	0,81
VCA1T 036 039	3,04	0,28	12,6	321	34,6	879	6,3	0,59	14,2	4,3	9,8	0,91
VCA1T 036 043	3,39	0,31	12,6	321	38,6	981	7,1	0,66	15,2	4,6	10,8	1,00
VCA1T 036 047	3,74	0,35	12,6	321	42,6	1083	7,9	0,73	16,2	4,9	11,8	1,09
VCA1T 038 015	1,01	0,09	13,6	346	10,6	270	1,7	0,16	8,6	2,6	4,0	0,37
VCA1T 038 019	1,38	0,13	13,6	346	14,6	371	2,6	0,24	9,6	2,9	5,0	0,47
VCA1T 038 023	1,76	0,16	13,6	346	18,6	473	3,4	0,32	10,6	3,2	6,1	0,56
VCA1T 038 027	2,14	0,20	13,6	346	22,6	575	4,2	0,39	11,6	3,5	7,1	0,66
VCA1T 038 031	2,52	0,23	13,6	346	26,6	676	5,1	0,47	12,6	3,8	8,2	0,76
VCA1T 038 035	2,90	0,27	13,6	346	30,6	778	5,9	0,55	13,6	4,1	9,2	0,86
VCA1T 038 039	3,28	0,30	13,6	346	34,6	879	6,8	0,63	14,6	4,4	10,3	0,96
VCA1T 038 043	3,65	0,34	13,6	346	38,6	981	7,6	0,71	15,6	4,7	11,3	1,05
VCA1T 038 047	4,03	0,37	13,6	346	42,6	1083	8,4	0,78	16,6	5,0	12,4	1,15
VCA1T 042 015	1,15	0,11	15,6	397	10,6	270	1,9	0,18	9,2	2,8	4,4	0,41
VCA1T 042 019	1,59	0,15	15,6	397	14,6	371	2,9	0,27	10,2	3,1	5,5	0,51
VCA1T 042 023	2,02	0,19	15,6	397	18,6	473	3,8	0,36	11,2	3,4	6,7	0,62
VCA1T 042 027	2,45	0,23	15,6	397	22,6	575	4,8	0,45	12,2	3,7	7,9	0,73
VCA1T 042 031	2,89	0,27	15,6	397	26,6	676	5,7	0,53	13,2	4,0	9,0	0,84
VCA1T 042 035	3,32	0,31	15,6	397	30,6	778	6,7	0,62	14,2	4,3	10,2	0,95
VCA1T 042 039	3,76	0,35	15,6	397	34,6	879	7,7	0,71	15,2	4,6	11,4	1,06
VCA1T 042 043	4,19	0,39	15,6	397	38,6	981	8,6	0,80	16,2	4,9	12,5	1,17
VCA1T 042 047	4,63	0,43	15,6	397	42,6	1083	9,6	0,89	17,2	5,3	13,7	1,27

# Architectural detail manual

## Horizontal double slider window DF3304



All vinyl

DF Windows® Collection

### Clear Opening and Daylight Specifications DF3304 All vinyl

Unit No.	Clear opening		Clear opening				Daylight Opening		Length of wetherstrip		Unit	
			Width		Height							
	Sq. Ft	Sq. met.	inch	mm	inch	mm	Sq. Ft	Sq. met.	lin. Ft	lin. met.	Sq. Ft	Sq. met.
VCA1T 046 015	1,30	0,12	17,6	448	10,6	270	2,2	0,20	9,9	3,0	4,8	0,45
VCA1T 046 019	1,79	0,17	17,6	448	14,6	371	3,2	0,30	10,9	3,3	6,1	0,56
VCA1T 046 023	2,28	0,21	17,6	448	18,6	473	4,3	0,40	11,9	3,6	7,3	0,68
VCA1T 046 027	2,77	0,26	17,6	448	22,6	575	5,4	0,50	12,9	3,9	8,6	0,80
VCA1T 046 031	3,26	0,30	17,6	448	26,6	676	6,4	0,60	13,9	4,2	9,9	0,92
VCA1T 046 035	3,75	0,35	17,6	448	30,6	778	7,5	0,70	14,9	4,5	11,2	1,04
VCA1T 046 039	4,24	0,39	17,6	448	34,6	879	8,5	0,79	15,9	4,8	12,5	1,16
VCA1T 046 043	4,73	0,44	17,6	448	38,6	981	9,6	0,89	16,9	5,1	13,7	1,28
VCA1T 046 047	5,22	0,48	17,6	448	42,6	1083	10,7	0,99	17,9	5,5	15,0	1,39
VCA1T 048 015	1,37	0,13	18,6	473	10,6	270	2,3	0,21	10,2	3,1	5,0	0,46
VCA1T 048 019	1,89	0,18	18,6	473	14,6	371	3,4	0,32	11,2	3,4	6,3	0,59
VCA1T 048 023	2,41	0,22	18,6	473	18,6	473	4,5	0,42	12,2	3,7	7,7	0,71
VCA1T 048 027	2,93	0,27	18,6	473	22,6	575	5,6	0,52	13,2	4,0	9,0	0,84
VCA1T 048 031	3,44	0,32	18,6	473	26,6	676	6,8	0,63	14,2	4,3	10,3	0,96
VCA1T 048 035	3,96	0,37	18,6	473	30,6	778	7,9	0,73	15,2	4,6	11,7	1,08
VCA1T 048 039	4,48	0,42	18,6	473	34,6	879	9,0	0,84	16,2	4,9	13,0	1,21
VCA1T 048 043	5,00	0,46	18,6	473	38,6	981	10,1	0,94	17,2	5,3	14,3	1,33
VCA1T 048 047	5,51	0,51	18,6	473	42,6	1083	11,2	1,04	18,2	5,6	15,7	1,46
VCA1T 050 015	1,45	0,13	19,6	498	10,6	270	2,4	0,22	10,6	3,2	5,2	0,48
VCA1T 050 019	1,99	0,19	19,6	498	14,6	371	3,6	0,33	11,6	3,5	6,6	0,61
VCA1T 050 023	2,54	0,24	19,6	498	18,6	473	4,7	0,44	12,6	3,8	8,0	0,74
VCA1T 050 027	3,08	0,29	19,6	498	22,6	575	5,9	0,55	13,6	4,1	9,4	0,87
VCA1T 050 031	3,63	0,34	19,6	498	26,6	676	7,1	0,66	14,6	4,4	10,8	1,00
VCA1T 050 035	4,17	0,39	19,6	498	30,6	778	8,3	0,77	15,6	4,7	12,2	1,13
VCA1T 050 039	4,72	0,44	19,6	498	34,6	879	9,4	0,88	16,6	5,0	13,5	1,26
VCA1T 050 043	5,26	0,49	19,6	498	38,6	981	10,6	0,99	17,6	5,4	14,9	1,39
VCA1T 050 047	5,81	0,54	19,6	498	42,6	1083	11,8	1,10	18,6	5,7	16,3	1,52
VCA1T 054 015	1,60	0,15	21,6	549	10,6	270	2,6	0,24	11,2	3,4	5,6	0,52
VCA1T 054 019	2,20	0,20	21,6	549	14,6	371	3,9	0,36	12,2	3,7	7,1	0,66
VCA1T 054 023	2,80	0,26	21,6	549	18,6	473	5,2	0,48	13,2	4,0	8,6	0,80
VCA1T 054 027	3,40	0,32	21,6	549	22,6	575	6,5	0,60	14,2	4,3	10,1	0,94
VCA1T 054 031	4,00	0,37	21,6	549	26,6	676	7,8	0,72	15,2	4,6	11,6	1,08
VCA1T 054 035	4,60	0,43	21,6	549	30,6	778	9,0	0,84	16,2	4,9	13,1	1,22
VCA1T 054 039	5,20	0,48	21,6	549	34,6	879	10,3	0,96	17,2	5,3	14,6	1,36
VCA1T 054 043	5,80	0,54	21,6	549	38,6	981	11,6	1,08	18,2	5,6	16,1	1,50
VCA1T 054 047	6,40	0,59	21,6	549	42,6	1083	12,9	1,20	19,2	5,9	17,6	1,64
VCA1T 058 015	1,74	0,16	23,6	600	10,6	270	2,8	0,26	11,9	3,6	6,0	0,56
VCA1T 058 019	2,40	0,22	23,6	600	14,6	371	4,2	0,39	12,9	3,9	7,7	0,71
VCA1T 058 023	3,06	0,28	23,6	600	18,6	473	5,6	0,52	13,9	4,2	9,3	0,86
VCA1T 058 027	3,71	0,34	23,6	600	22,6	575	7,0	0,65	14,9	4,5	10,9	1,01
VCA1T 058 031	4,37	0,41	23,6	600	26,6	676	8,4	0,78	15,9	4,8	12,5	1,16
VCA1T 058 035	5,02	0,47	23,6	600	30,6	778	9,8	0,91	16,9	5,1	14,1	1,31
VCA1T 058 039	5,68	0,53	23,6	600	34,6	879	11,2	1,04	17,9	5,5	15,7	1,46
VCA1T 058 043	6,34	0,59	23,6	600	38,6	981	12,6	1,17	18,9	5,8	17,3	1,61
VCA1T 058 047	6,99	0,65	23,6	600	42,6	1083	14,0	1,30	19,9	6,1	18,9	1,76
VCA1T 060 015	1,82	0,17	24,6	625	10,6	270	3,0	0,27	12,2	3,7	6,3	0,58
VCA1T 060 019	2,50	0,23	24,6	625	14,6	371	4,4	0,41	13,2	4,0	7,9	0,74
VCA1T 060 023	3,19	0,30	24,6	625	18,6	473	5,9	0,54	14,2	4,3	9,6	0,89
VCA1T 060 027	3,87	0,36	24,6	625	22,6	575	7,3	0,68	15,2	4,6	11,3	1,05
VCA1T 060 031	4,55	0,42	24,6	625	26,6	676	8,8	0,81	16,2	4,9	12,9	1,20
VCA1T 060 035	5,24	0,49	24,6	625	30,6	778	10,2	0,95	17,2	5,3	14,6	1,35
VCA1T 060 039	5,92	0,55	24,6	625	34,6	879	11,7	1,08	18,2	5,6	16,3	1,51
VCA1T 060 043	6,61	0,61	24,6	625	38,6	981	13,1	1,22	19,2	5,9	17,9	1,66
VCA1T 060 047	7,29	0,68	24,6	625	42,6	1083	14,6	1,35	20,2	6,2	19,6	1,82

# Architectural detail manual

## Horizontal double slider window DF3304



All vinyl

DF Windows® Collection

### Clear Opening and Daylight Specifications

#### DF3304 All vinyl

Unit No.	Clear opening		Clear opening				Daylight Opening		Length of wetherstrip		Unit	
			Width		Height							
	Sq. Ft	Sq. met.	inch	mm	inch	mm	Sq. Ft	Sq. met.	lin. Ft	lin. met.	Sq. Ft	Sq. met.
VCA1T 062 015	1,89	0,18	25,6	651	10,6	270	3,1	0,29	12,6	3,8	6,5	0,60
VCA1T 062 019	2,60	0,24	25,6	651	14,6	371	4,6	0,43	13,6	4,1	8,2	0,76
VCA1T 062 023	3,31	0,31	25,6	651	18,6	473	6,1	0,57	14,6	4,4	9,9	0,92
VCA1T 062 027	4,03	0,37	25,6	651	22,6	575	7,6	0,71	15,6	4,7	11,6	1,08
VCA1T 062 031	4,74	0,44	25,6	651	26,6	676	9,1	0,85	16,6	5,0	13,3	1,24
VCA1T 062 035	5,45	0,51	25,6	651	30,6	778	10,6	0,99	17,6	5,4	15,1	1,40
VCA1T 062 039	6,16	0,57	25,6	651	34,6	879	12,1	1,13	18,6	5,7	16,8	1,56
VCA1T 062 043	6,87	0,64	25,6	651	38,6	981	13,6	1,27	19,6	6,0	18,5	1,72
VCA1T 062 047	7,59	0,70	25,6	651	42,6	1083	15,1	1,41	20,6	6,3	20,2	1,88
VCA1T 066 015	2,04	0,19	27,6	702	10,6	270	3,3	0,31	13,2	4,0	6,9	0,64
VCA1T 066 019	2,81	0,26	27,6	702	14,6	371	4,9	0,46	14,2	4,3	8,7	0,81
VCA1T 066 023	3,57	0,33	27,6	702	18,6	473	6,5	0,61	15,2	4,6	10,5	0,98
VCA1T 066 027	4,34	0,40	27,6	702	22,6	575	8,2	0,76	16,2	4,9	12,4	1,15
VCA1T 066 031	5,11	0,47	27,6	702	26,6	676	9,8	0,91	17,2	5,3	14,2	1,32
VCA1T 066 035	5,88	0,55	27,6	702	30,6	778	11,4	1,06	18,2	5,6	16,0	1,49
VCA1T 066 039	6,64	0,62	27,6	702	34,6	879	13,0	1,21	19,2	5,9	17,9	1,66
VCA1T 066 043	7,41	0,69	27,6	702	38,6	981	14,6	1,36	20,2	6,2	19,7	1,83
VCA1T 066 047	8,18	0,76	27,6	702	42,6	1083	16,3	1,51	21,2	6,5	21,5	2,00
VCA1T 070 015	2,19	0,20	29,6	752	10,6	270	3,5	0,33	13,9	4,2	7,3	0,68
VCA1T 070 019	3,01	0,28	29,6	752	14,6	371	5,3	0,49	14,9	4,5	9,2	0,86
VCA1T 070 023	3,83	0,36	29,6	752	18,6	473	7,0	0,65	15,9	4,8	11,2	1,04
VCA1T 070 027	4,65	0,43	29,6	752	22,6	575	8,7	0,81	16,9	5,1	13,1	1,22
VCA1T 070 031	5,48	0,51	29,6	752	26,6	676	10,4	0,97	17,9	5,5	15,1	1,40
VCA1T 070 035	6,30	0,59	29,6	752	30,6	778	12,2	1,13	18,9	5,8	17,0	1,58
VCA1T 070 039	7,12	0,66	29,6	752	34,6	879	13,9	1,29	19,9	6,1	19,0	1,76
VCA1T 070 043	7,95	0,74	29,6	752	38,6	981	15,6	1,45	20,9	6,4	20,9	1,94
VCA1T 070 047	8,77	0,81	29,6	752	42,6	1083	17,4	1,61	21,9	6,7	22,8	2,12
VCA1T 072 015	2,26	0,21	30,6	778	10,6	270	3,6	0,34	14,2	4,3	7,5	0,70
VCA1T 072 019	3,11	0,29	30,6	778	14,6	371	5,4	0,50	15,2	4,6	9,5	0,88
VCA1T 072 023	3,96	0,37	30,6	778	18,6	473	7,2	0,67	16,2	4,9	11,5	1,07
VCA1T 072 027	4,81	0,45	30,6	778	22,6	575	9,0	0,84	17,2	5,3	13,5	1,25
VCA1T 072 031	5,66	0,53	30,6	778	26,6	676	10,8	1,00	18,2	5,6	15,5	1,44
VCA1T 072 035	6,51	0,61	30,6	778	30,6	778	12,6	1,17	19,2	5,9	17,5	1,63
VCA1T 072 039	7,36	0,68	30,6	778	34,6	879	14,4	1,33	20,2	6,2	19,5	1,81
VCA1T 072 043	8,21	0,76	30,6	778	38,6	981	16,1	1,50	21,2	6,5	21,5	2,00
VCA1T 072 047	9,07	0,84	30,6	778	42,6	1083	17,9	1,67	22,2	6,8	23,5	2,18
VCA1T 074 015	2,33	0,22	31,6	803	10,6	270	3,8	0,35	14,6	4,4	7,7	0,72
VCA1T 074 019	3,21	0,30	31,6	803	14,6	371	5,6	0,52	15,6	4,7	9,8	0,91
VCA1T 074 023	4,09	0,38	31,6	803	18,6	473	7,4	0,69	16,6	5,0	11,8	1,10
VCA1T 074 027	4,97	0,46	31,6	803	22,6	575	9,3	0,86	17,6	5,4	13,9	1,29
VCA1T 074 031	5,85	0,54	31,6	803	26,6	676	11,1	1,03	18,6	5,7	15,9	1,48
VCA1T 074 035	6,73	0,62	31,6	803	30,6	778	13,0	1,20	19,6	6,0	18,0	1,67
VCA1T 074 039	7,60	0,71	31,6	803	34,6	879	14,8	1,37	20,6	6,3	20,0	1,86
VCA1T 074 043	8,48	0,79	31,6	803	38,6	981	16,6	1,55	21,6	6,6	22,1	2,05
VCA1T 074 047	9,36	0,87	31,6	803	42,6	1083	18,5	1,72	22,6	6,9	24,2	2,24