TABLE OF CONTENTS

Specifications.....	1 - 2
Quick Spec Guide	1 - 3
Clear Opening and Daylight Specifications	1 - 5
General Information	
Multiple Assemblies	1 - 6
Handing and Operation	1 - 7
Elevation Drawing Guide	1 - 8
Elevation Drawings	
22" - 42" Units (1 Wide)	1 - 9
46" - 50" Units (1 Wide)	1 - 10
22" - 42" Units (1 over 1 uneven units)	1 - 11
46" - 50" Units (1 over 1 uneven units)	1 - 12
22" - 42" Units (1 over 1 even units).....	1 - 13
46" - 50" Units (1 over 1 even units).....	1 - 14
Detail Drawings	
Glazing Options - Internal Grilles - Tripane	1 - 15
Glazing Options - Internal Grilles - Dualpane.....	1 - 16
Glazing Options - Simulated Divided Lites & False Mullions - Tripane	1 - 17
Glazing Options - Simulated Divided Lites & False Mullions - Dualpane.....	1 - 18
Jamb Extension Options - Aluminum	1 - 19
Jamb Extension Options - Wood.....	1 - 20
Mullion Details.....	1 - 21
Trim Options - Flush Frame with and without Flange	1 - 22
Trim Options - 1 1/2" Brickmould with and without Flange	1 - 23
Trim Options - 3 1/2" Brickmould with and without Flange	1 - 24
90° Corner Mullion.....	1 - 25

SPECIFICATIONS

MATERIAL

The vinyl and extruded aluminum window profiles meet the AAMA 303-97 performance requirements.

WINDOW FRAME

Vinyl:

All frames are assembled using a fusion welding technology for strength and durability. The depth of the frame is 3 1/4" (83 mm), and the thickness of the outer wall 0.065 inch. The frames are provided with groove for attaching external moldings and come with a built-in adaptor for 1/2-3/4 inch. Closed frame version is also available for replacement.

Aluminum:

The frame cladding is made of extruded aluminum and coated with a baked paint. A nailing fin is integrated into the frame for superior sealing. The mechanical connection with corner injection provides good rigidity and allows application of sealant. The double seal provides optimum sealing.

SASH

Vinyl:

The sash has a thickness of 2 1/4" (nominal) or (54.61 mm), it is assembled using a fusion welding technology for strength and durability.

Aluminum:

The aluminum sash cladding is screwed for easy replacement of parts. Limited points of contact between aluminum and pvc minimize thermal transmittance. The mechanical assembly with double corners on all 4 corners results in a very strong sash.

GLAZING

Sealed unit, 3/4" (19 mm) consists of two panes of glass sealed around an interlayer insulation with double sealing. All insulating glass meet the performance requirements of the standard under IGMAC CAN/CGSB-12.8-97.

GLAZING OPTIONS

The Sealed unit, 3/4 in. (19 mm) is available in clear glass, low-emissivity (low-E) with Argon, tinted or frosted, or any other type of architectural glass upon request. All glasses are available tempered. Sealed unit up to 7/8" is available in option also is a triple glass of 1 1/4" sealed unit.

WEATHERSTRIPPING

Weatherstripping with fin brush is applied around the perimeter of the sash. The double row of weatherstripping coextruded meets AAMA 701 or AAMA 702. A weatherstrip is applied to the entire perimeter of the frame.

HARDWARE

Awning windows have a double lever operator with anticorrosion coating and a multipoint locking system. The finish of the operators is a hardware brand offered by Truth with a folding handle.

WINDOW SCREEN

The insect screen is made in fiberglass (tread 18 x 16) installed in a folded aluminum painted frame, adjusted within the window. The screens are designed to bring air and light while keeping insects out, not to prevent a person or object falling through an open window. For more information on screens or other security devices, contact your retailer of building materials locally.

GRILLES

Simulated divided lite (SDL) made of vinyl inside and outside aluminum, 7/8 in. (23 mm) and 1 3/8 (35 mm) or SDL vinyl inside and aluminum outside 2 5/16 inch (59 mm) fixed permanently on each side of the insulating pane with or without spacer between the glass panes.

Sealed grilles (grilles between the glass) - Georgian style, tubular, square or flat mounted between the glass panes suspended within the empty space.

INSTALLATION

Install vinyl windows in accordance with JELD-WEN installation method. Visit www.jeld-wen.com/resources for instructions.

PERFORMANCE

CSA certified - classified and labeled in accordance with CSA certification program NFRC Certified - (classified and labeled in accordance with NFRC certification program). EnergyStar certified - (classified and labeled according to EnergyStar certification program).

QUICK SPEC GUIDE

SPECIFICATIONS	STANDARD FEATURES	OPTIONAL FEATURES
Colour	<ul style="list-style-type: none"> • White • Black • Commercial Brown • Pebble • Slate 	DF Colour Chart
Module Dimension	<ul style="list-style-type: none"> • Width: 20 3/4" to 50" • Height: 13 3/4" to 42" 	Any size with minimum and maximum parameters
Frame	<ul style="list-style-type: none"> • Exterior Groove • 1/2"-3/4" Integrated Adaptor • Mechanical assembly with injections corners 	
Exterior Moulding	<ul style="list-style-type: none"> • Exterior Groove • 1 1/2" Moulding with or without nailing fin • 3 1/2" Moulding with or without nailing fin 	
Glazing	<ul style="list-style-type: none"> • Clear glazing with insulating spacer 	<ul style="list-style-type: none"> - Triple pane - Low emissivity with argon gas - Frosted - Bronze - Grey - Glue chip - Satin - Laminated - All glasses are available tempered
Hardware	<ul style="list-style-type: none"> • Rotogear operator • Folding handle 	
Hardware Colour	<ul style="list-style-type: none"> • White (device is visible when window is closed) 	
Screen	<ul style="list-style-type: none"> • Fibreglass mesh 	
Colour of Screen Frame	<ul style="list-style-type: none"> • White 	
Grilles		<ul style="list-style-type: none"> - Simulated divided lite (SDL) of 7/8" and 1 3/8" with or without spacer bar - False mullion of 2 5/16" with or without spacer bar Georgian sealed grilles <ul style="list-style-type: none"> - White - Commercial Brown/White - Pebble/White - Slate/White - Black/White - Other colours available upon request Tubular sealed grilles <ul style="list-style-type: none"> - White - Brass - Grey - Pewter

QUICK SPEC GUIDE CONT'D

SPECIFICATIONS	STANDARD FEATURES	OPTIONAL FEATURES
Grilles cont'd		Square sealed grilles - White - Brass - Grey - Pewter Flat sealed grilles - White - Other colours available in duo/white
Frame depth	<ul style="list-style-type: none"> • 4 9/16" behind nailing fin. Overall frame depth of 5 13/16" 	- Closed or opened interior frame - Interior vinyl clad frame extension

CLEAR OPENING AND DAYLIGHT SPECIFICATIONS

Unit No.	Daylight Opening		Length of wetherstrip		Unit	
	Sq. Ft	Sq. met.	lin. Ft	lin. met.	Sq. Ft	Sq. met.
VL10T022 023	1,8	0,17	6,7	2,0	3,5	0,33
VL10T022 031	2,7	0,25	8,0	2,4	4,7	0,44
VL10T022 039	3,5	0,33	9,3	2,8	6,0	0,55
VL10T022 042	3,9	0,36	9,8	3,0	6,4	0,60
VL10T026 023	2,3	0,21	7,3	2,2	4,2	0,39
VL10T026 031	3,4	0,31	8,7	2,6	5,6	0,52
VL10T026 039	4,4	0,41	10,0	3,0	7,0	0,65
VL10T026 042	4,9	0,45	10,5	3,2	7,6	0,70
VL10T030 023	2,7	0,25	8,0	2,4	4,8	0,45
VL10T030 031	4,0	0,38	9,3	2,8	6,5	0,60
VL10T030 039	5,4	0,50	10,7	3,2	8,1	0,75
VL10T030 042	5,8	0,54	11,2	3,4	8,8	0,81
VL10T034 023	3,2	0,30	8,7	2,6	5,4	0,50
VL10T034 031	4,7	0,44	10,0	3,0	7,3	0,68
VL10T034 039	6,3	0,58	11,3	3,5	9,2	0,86
VL10T034 042	6,8	0,63	11,8	3,6	9,9	0,92
VL10T036 023	3,4	0,32	9,0	2,7	5,8	0,53
VL10T036 031	5,1	0,47	10,3	3,1	7,8	0,72
VL10T036 039	6,7	0,62	11,7	3,6	9,8	0,91
VL10T036 042	7,3	0,68	12,2	3,7	10,5	0,98
VL10T038 023	3,7	0,34	9,3	2,8	6,1	0,56
VL10T038 031	5,4	0,50	10,7	3,2	8,2	0,76
VL10T038 039	7,2	0,67	12,0	3,7	10,3	0,96
VL10T038 042	7,8	0,73	12,5	3,8	11,1	1,03
VL10T042 023	4,1	0,38	10,0	3,0	6,7	0,62
VL10T042 031	6,1	0,57	11,3	3,5	9,0	0,84
VL10T042 039	8,1	0,75	12,7	3,9	11,4	1,06
VL10T042 042	8,8	0,82	13,2	4,0	12,3	1,14
VL10T046 023	4,6	0,42	10,7	3,2	7,3	0,68
VL10T046 031	6,8	0,63	12,0	3,7	9,9	0,92
VL10T046 039	9,0	0,83	13,3	4,1	12,5	1,16
VL10T046 042	9,8	0,91	13,8	4,2	13,4	1,25
VL10T048 066	17,2	1,60	18,2	5,5	22,0	2,04
VL10T048 070	18,4	1,71	18,8	5,7	23,3	2,17
VL10T048 074	19,5	1,82	19,5	5,9	24,7	2,29
VL10T048 078	20,7	1,92	20,2	6,1	26,0	2,42
VL10T050 066	18,1	1,68	18,5	5,6	22,9	2,13
VL10T050 070	19,3	1,79	19,2	5,8	24,3	2,26
VL10T050 074	20,5	1,90	19,8	6,0	25,7	2,39
VL10T050 078	21,7	2,02	20,5	6,2	27,1	2,52

MULTIPLE ASSEMBLIES

All hybrid awning windows may be mullered above, below, or beside other hybrid awning windows, or other hybrid window products. Factory assembled mulls are limited in height (99"), width (150"), and a total area (60 square feet).

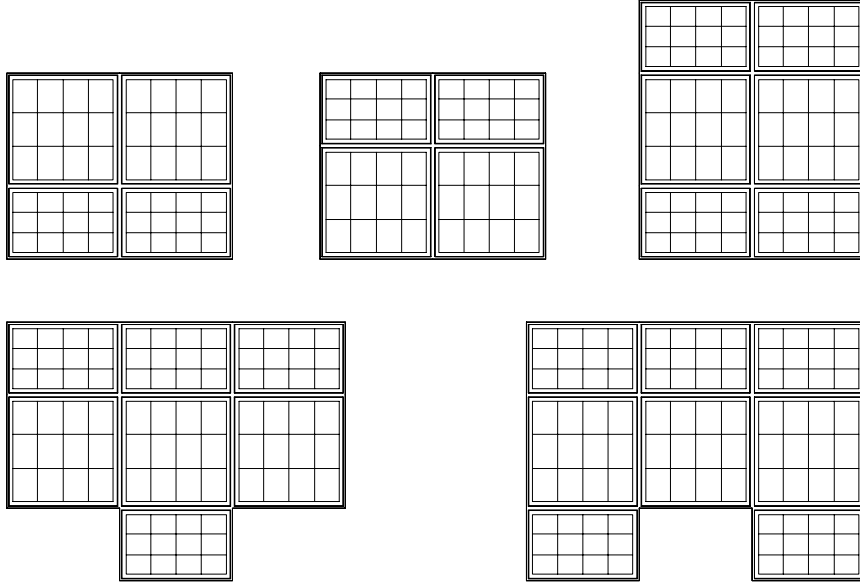

HANDING AND OPERATION

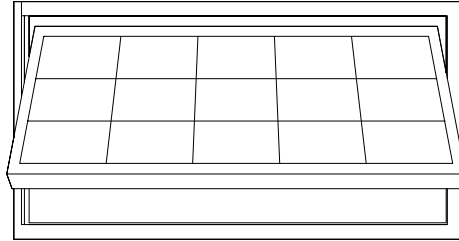

ELEVATION DRAWING GUIDE

Height:
 Rough Opening 42 3/4" - 1086mm
 Frame Size 42" - 1067mm
 Glass Size 35 5/8" - 905mm

Width:
 Rough Opening 34 3/4" - 883mm
 Frame Size 34" - 864mm
 Glass Size 27 5/8" - 702mm

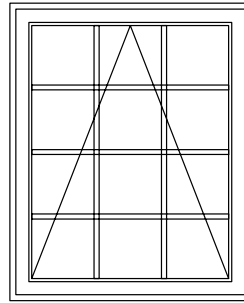

OUTSIDE OF FRAME

VL10T034042

BOOK CODE

'VL' INDICATES
 DF3113 HYBRID AWNING SERIES

THE FIRST DIGIT INDICATES THE NUMBER
 OF UNITS MULLED TOGETHER IN WIDTH

'T' INDICATES DUAL
 GLAZED PRODUCT

THE NEXT THREE NUMBERS INDICATE
 THE UNIT HEIGHT IN INCHES

THE FIRST THREE NUMBERS
 INDICATE THE UNIT WIDTH IN INCHES

GENERAL AWNING NOTES

1. HYBRID AWNING UNITS ARE AVAILABLE AS OPERATING OR STATIONARY UNITS.
2. UNIT ELEVATIONS ARE SHOWN WITHOUT EXTERIOR TRIM.

AWNING PICTURE COMBINATIONS

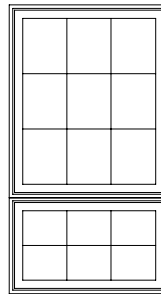

VL10BT042070

INDICATES A TOP FIXED
 SASH COMBINATION,
 UNLESS SPECIFIED,
 LOWER UNIT IS ALWAYS
 23" IN HEIGHT

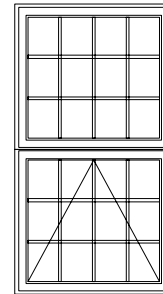

VL10CT038070

INDICATES A TOP
 FIXED SASH
 COMBINATION,
 SPLIT HALF/HALF

22" - 42" Units (1 Wide)

	22 3/4" • 578mm 22" • 559mm 15 5/8" • 397mm	26 3/4" • 679mm 26" • 660mm 19 5/8" • 498mm	30 3/4" • 781mm 30" • 762mm 23 5/8" • 600mm	34 3/4" • 883mm 34" • 864mm 27 5/8" • 702mm	36 3/4" • 984mm 36" • 965mm 29 5/8" • 752mm	38 3/4" • 984mm 38" • 965mm 31 5/8" • 803mm	42 3/4" • 1086mm 42" • 1067mm 35 5/8" • 905mm
Dim. Cat. CADRE VERRE RSO 23 3/4" • 603mm 18 5/8" • 472mm							
22 3/4" • 578mm 22" • 559mm 15 5/8" • 397mm							
31 3/4" • 806mm 24 5/8" • 625mm							
38 3/4" • 1010mm 32 5/8" • 829mm							
42 3/4" • 1086mm 35 5/8" • 905mm							

46" - 50" Units (1 Wide)

Dim. Col.
 RSO CADRE
 FRAME VERRE
 GLASS

23 3/4" • 603mm
 23 3/8" • 594mm
 16 5/8" • 422mm

31 3/4" • 806mm
 31" • 787mm
 24 5/8" • 623mm

39 3/4" • 1010mm
 39" • 991mm
 32 5/8" • 829mm

42 3/4" • 1086mm
 42" • 1067mm
 35 5/8" • 903mm

46 3/4" • 1187mm
 46" • 1168mm
 39 5/8" • 1006mm

48 3/4" • 1236mm
 48" • 1219mm
 41 5/8" • 1057mm

50 3/4" • 1289mm
 50" • 1270mm
 43 5/8" • 1108mm

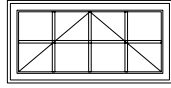

VL10T046023

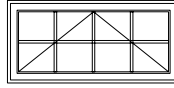

VL10T048023

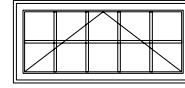

VL10T050023

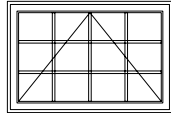

VL10T046031

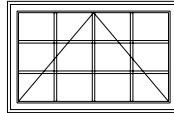

VL10T048031

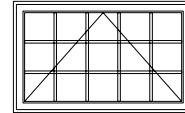

VL10T050031

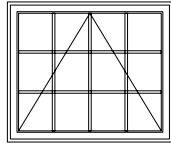

VL10T046039

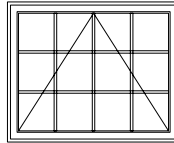

VL10T048039

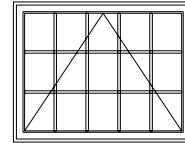

VL10T050039

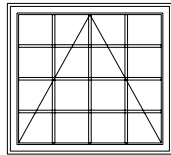

VL10T046042

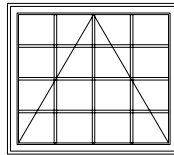

VL10T048042

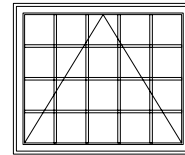

VL10T050042

22" - 42" Units (1 over 1 uneven units)

Dim.Col. CADRE FRAME GLASS VERRE	22 3/4"•578mm 22"•559mm 15 5/8"•397mm	26 3/4"•679mm 26"•660mm 19 5/8"•498mm	30 3/4"•781mm 30"•762mm 23 5/8"•600mm	34 3/4"•883mm 34"•864mm 27 5/8"•702mm	38 3/4"•984mm 38"•965mm 31 5/8"•803mm	42 3/4"•1086mm 42"•1067mm 35 5/8"•905mm
54 16 5/8"•422mm						
62 16 5/8"•422mm						
70 16 5/8"•422mm						
78 16 5/8"•422mm						

46" - 50" Units (1 over 1 uneven units)

RES
 Dim Col
 CADRE
 VERRE

46 3/4" • 1187mm
 46" • 1168mm
 39 5/8" • 1006mm

50 3/4" • 1289mm
 50" • 1270mm
 43 5/8" • 1108mm

54 3/4" • 1391mm
 16 5/8" • 422mm

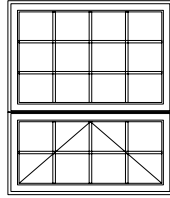

VL10BT046054

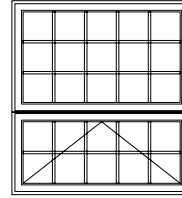

VL10BT050054

62 3/4" • 1594mm
 16 5/8" • 422mm

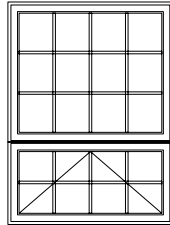

VL10BT046062

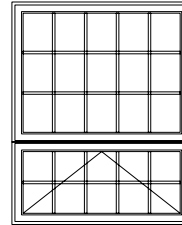

VL10BT050062

70 3/4" • 1797mm
 16 5/8" • 422mm

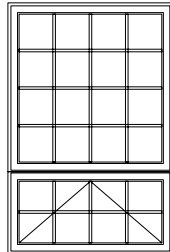

VL10BT046070

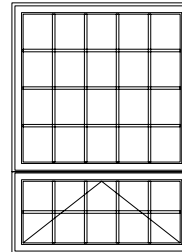

VL10BT050070

78 3/4" • 2000mm
 16 5/8" • 422mm

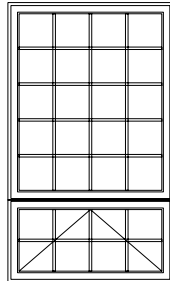

VL10BT046078

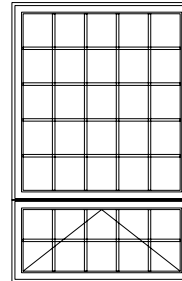

VL10BT050078

22" - 42" Units (1 over 1 even units)

DF On Call FRAME GLASS VERRE	22 3/4" • 578mm 22" • 559mm 15 5/8" • 397mm	26 3/4" • 679mm 26" • 660mm 19 5/8" • 498mm	30 3/4" • 781mm 30" • 762mm 23 5/8" • 600mm	34 3/4" • 883mm 34" • 864mm 27 5/8" • 702mm	38 3/4" • 984mm 38" • 965mm 31 5/8" • 803mm	42 3/4" • 1085mm 42" • 1067mm 35 5/8" • 905mm
38 3/4" • 984mm 38" • 965mm 12 5/8" • 321mm						
VL10CT022038	VL10CT026038	VL10CT030038	VL10CT034038	VL10CT038038	VL10CT042038	
46 3/4" • 1187mm 46" • 1168mm 16 5/8" • 422mm						
VL10CT02246	VL10CT02646	VL10CT03046	VL10CT03446	VL10CT03846	VL10CT04246	
54 3/4" • 1391mm 54" • 1369mm 20 5/8" • 524mm						
VL10CT022054	VL10CT026054	VL10CT030054	VL10CT034054	VL10CT038054	VL10CT042054	
62 3/4" • 1594mm 62" • 1572mm 24 5/8" • 625mm						
VL10CT022062	VL10CT026062	VL10CT030062	VL10CT034062	VL10CT038062	VL10CT042062	
70 3/4" • 1797mm 70" • 1776mm 28 5/8" • 727mm						
VL10CT022070	VL10CT026070	VL10CT030070	VL10CT034070	VL10CT038070	VL10CT042070	
78 3/4" • 1999mm 78" • 1981mm 32 5/8" • 829mm						
VL10CT022078	VL10CT026078	VL10CT030078	VL10CT034078	VL10CT038078	VL10CT042078	

46" - 50" Units (1 over 1 even units)

Dim Col
 RSO
 FRAME CADRE
 GLASS VERRRE

46 3/4" • 1187mm
 46" • 1168mm
 39 5/8" • 1006mm

50 3/4" • 1289mm
 50" • 1270mm
 43 5/8" • 1108mm

38 3/4" • 603mm
 38" • 594mm
 12 5/8" • 321mm

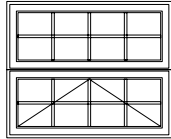

VL10CT046038

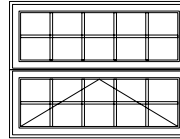

VL10CT050038

46 3/4" • 1187mm
 46" • 1168mm
 16 5/8" • 421mm

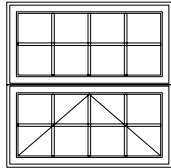

VL10CT04646

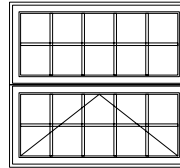

VL10CT05046

54 3/4" • 1397mm
 54" • 1388mm
 20 5/8" • 524mm

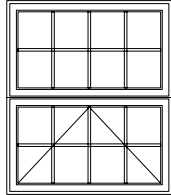

VL10CT046054

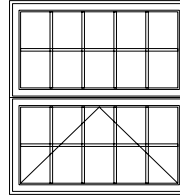

VL10CT050054

62 3/4" • 1594mm
 62" • 1575mm
 24 5/8" • 621mm

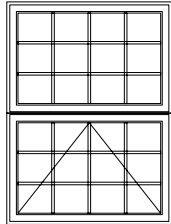

VL10CT046062

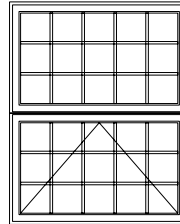

VL10CT050062

70 3/4" • 1797mm
 70" • 1778mm
 28 5/8" • 727mm

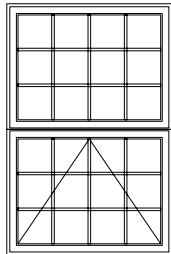

VL10CT046070

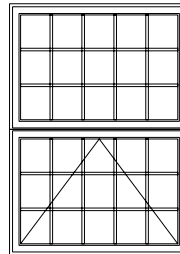

VL10CT050070

78 3/4" • 2000mm
 78" • 1981mm
 32 5/8" • 833mm

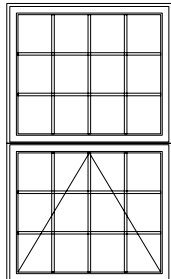

VL10CT046078

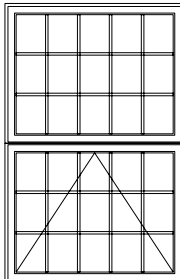

VL10CT050078

GLAZING OPTIONS - INTERNAL GRILLES - TRIPANE

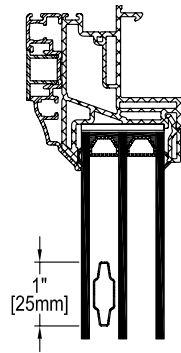

Georgian 1"

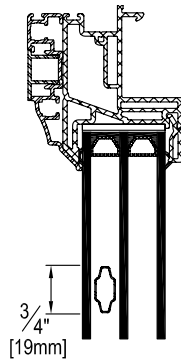

Georgian

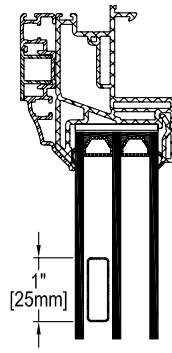

Plat 1"
1" Flat

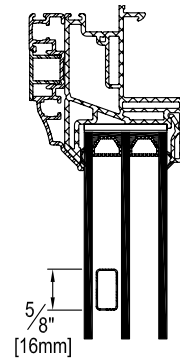

Plat
Flat

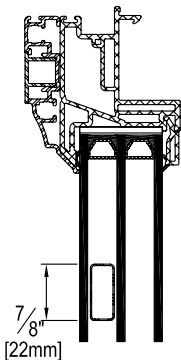

Intercalaire
Spacer bar

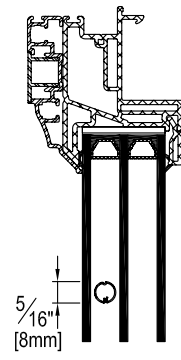

Tubulaire
Pencil bar

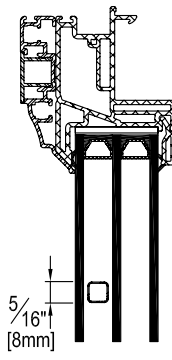

Carré
Square

GLAZING OPTIONS - INTERNAL GRILLES - DUALPANE

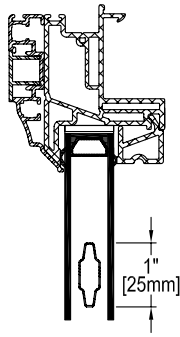

Georgian 1"

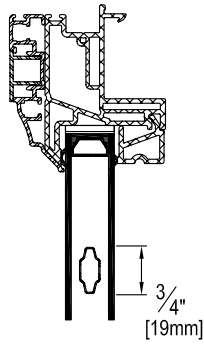

Georgian

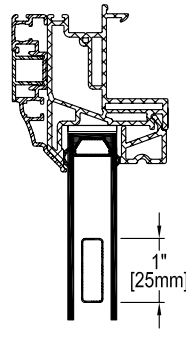

Plat 1"
1" Flat

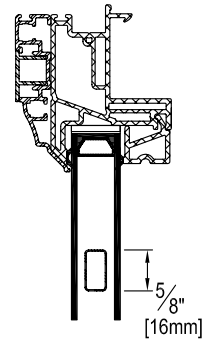

Plat
Flat

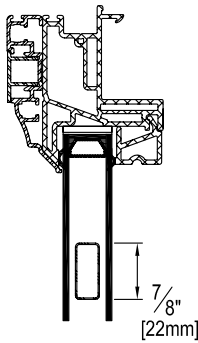

Intercalaire
Spacer bar

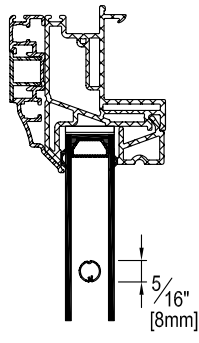

Tubulaire
Pencil bar

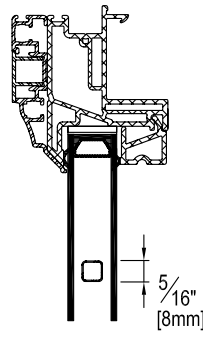

Carré
Square

GLAZING OPTIONS - SIMULATED DIVIDED LITES & FALSE MULLIONS - TRIPANE

Simili barrotin avec intercalaire
Simulated divided lite with spacer-bar

Simili barrotin
Simulated divided lite

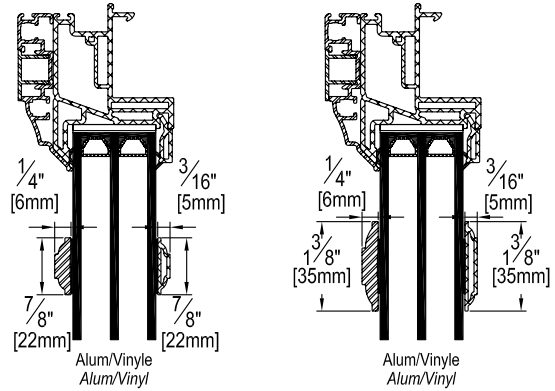
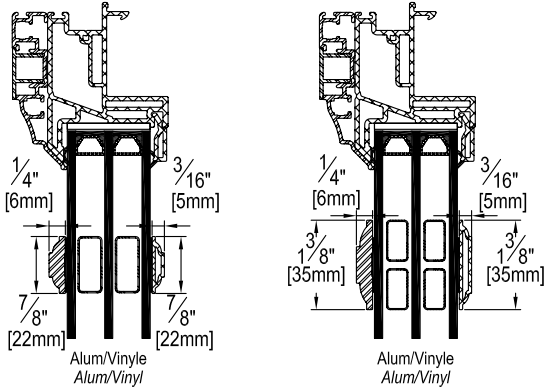

Faux-meneau avec intercalaire
False mullion with spacer-bar

Faux-meneau
False mullion

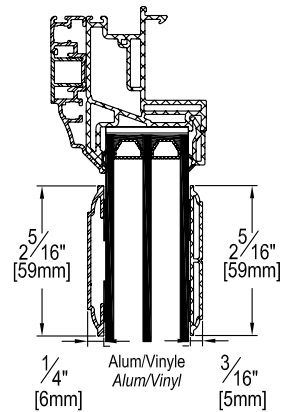
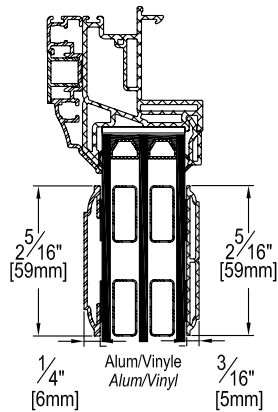

GLAZING OPTIONS - SIMULATED DIVIDED LITES & FALSE MULLIONS - DUALPANE

Simili barrotin avec intercalaire
Simulated divided lite with spacer-bar

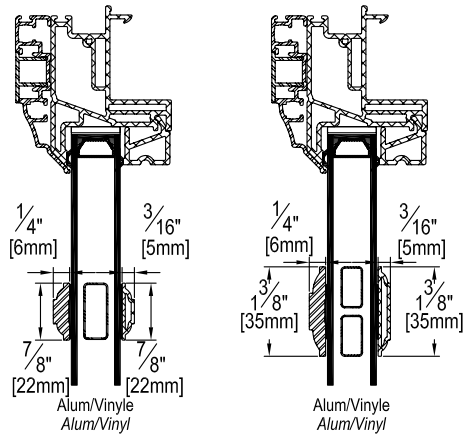

Simili barrotin
Simulated divided lite

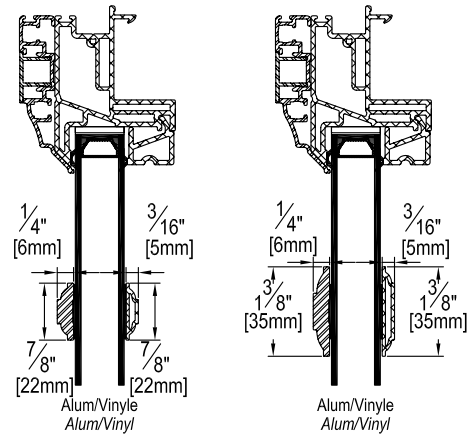

Faux-meneau avec intercalaire
False mullion with spacer-bar

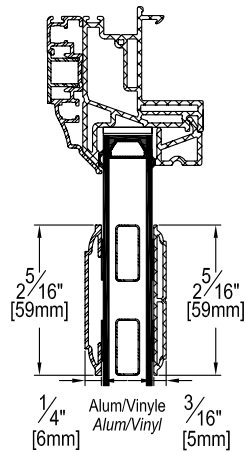

Faux-meneau
False mullion

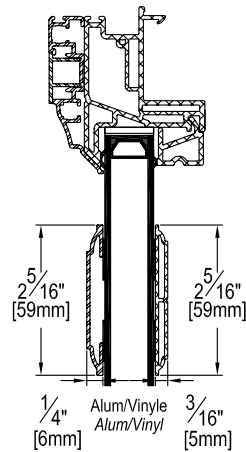

JAMB EXTENSION OPTIONS - ALUMINUM

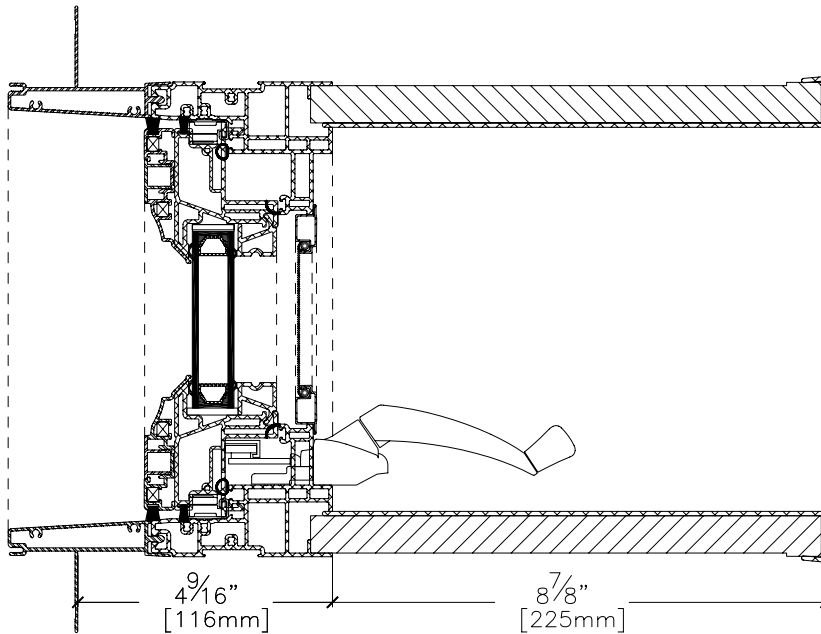
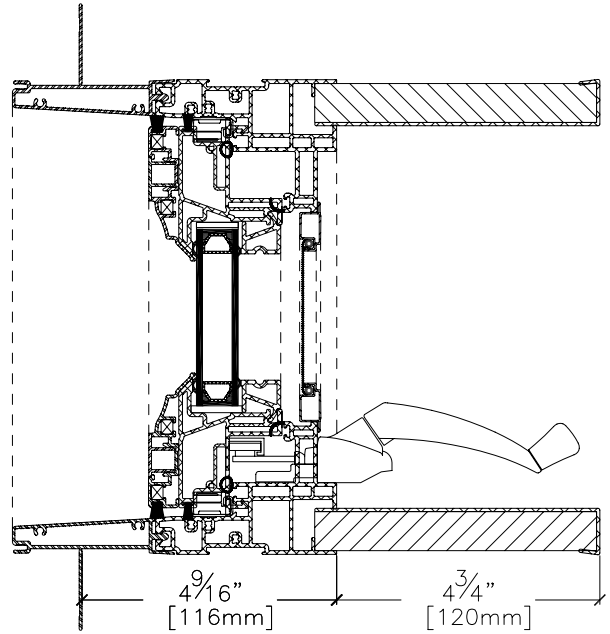
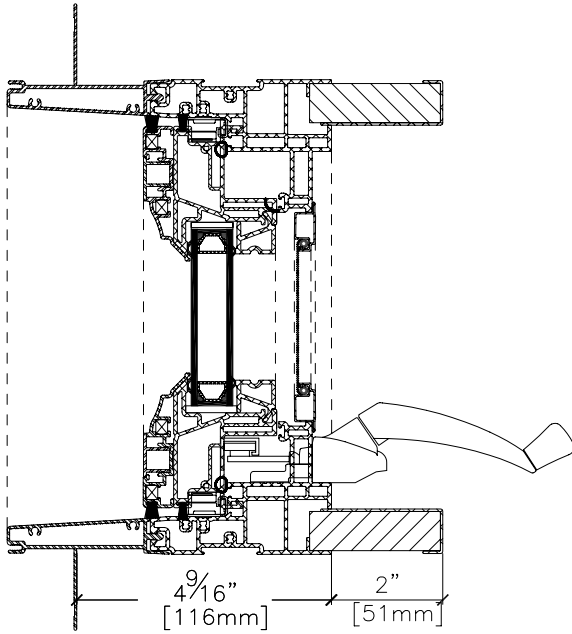

JAMB EXTENSION OPTIONS - WOOD

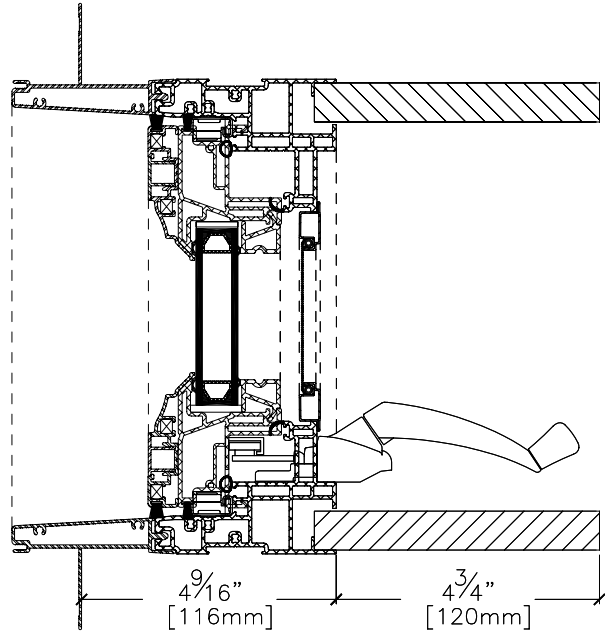
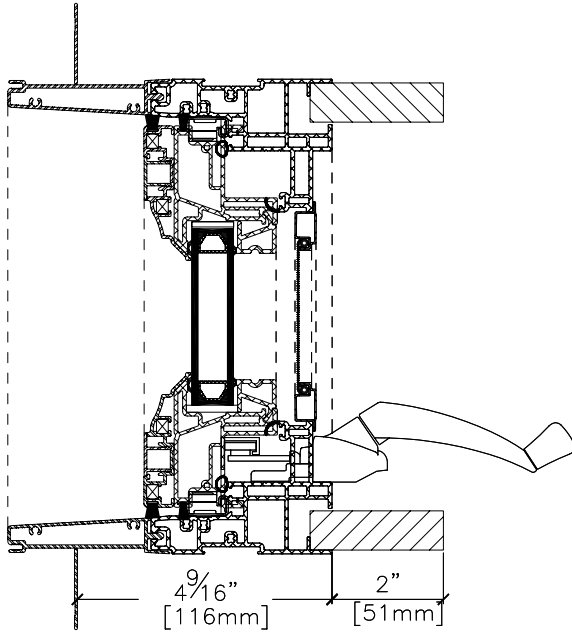

MULLION DETAILS

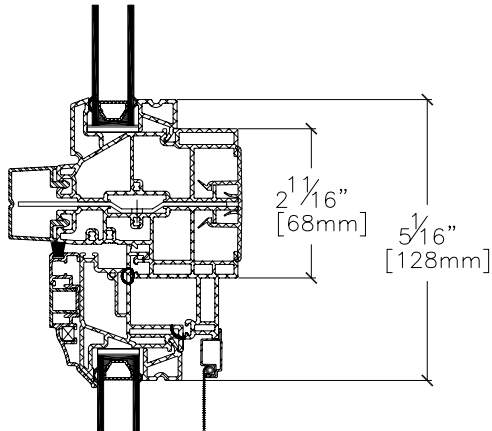

Imposte verre scellé fixe
Cadre de vinyle
Transom with fixed lite
Vinyl frame

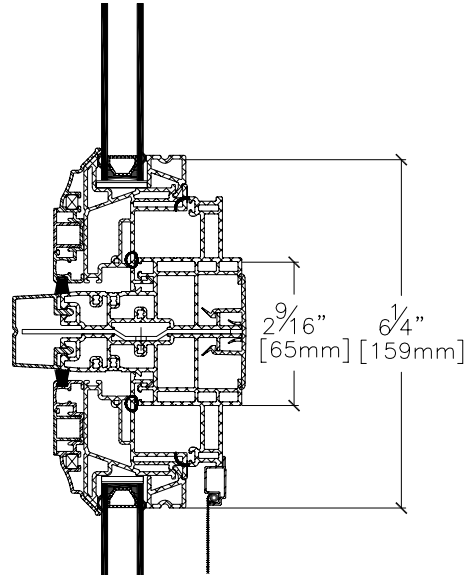

Imposte volet fixe
Cadre de vinyle
Transom with fixed sash
Vinyl frame

TRIM OPTIONS - FLUSH FRAME WITH AND WITHOUT FLANGE

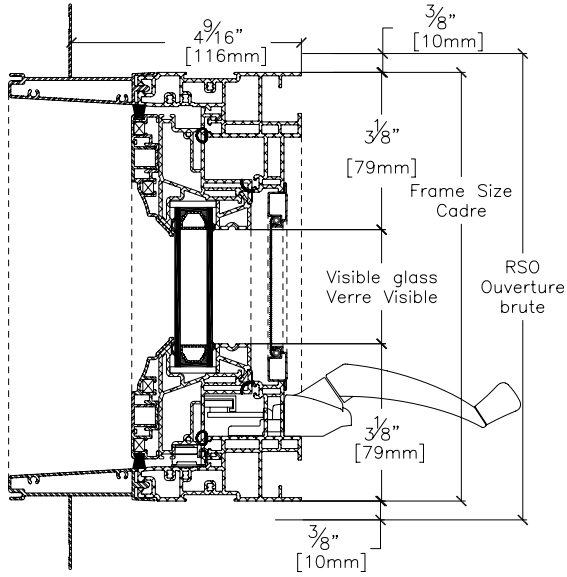

4 9/16" flush avec lame
 4 9/16" flush frame with flange

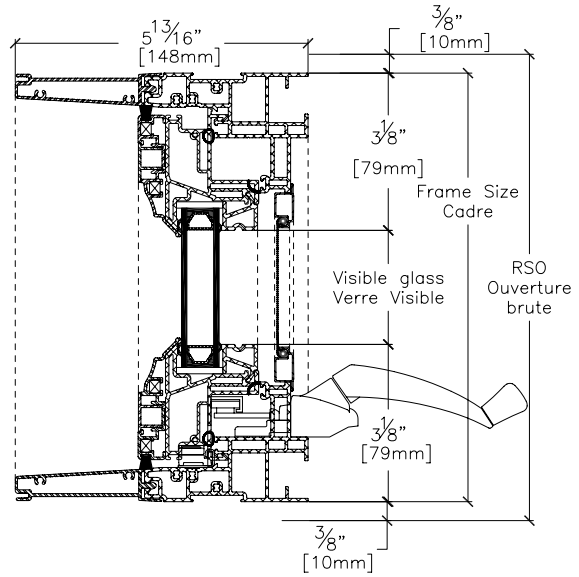

4 9/16" flush sans lame
 4 9/16" flush frame without flange

TRIM OPTIONS - 3 1/2" BRICKMOULD WITH AND WITHOUT FLANGE

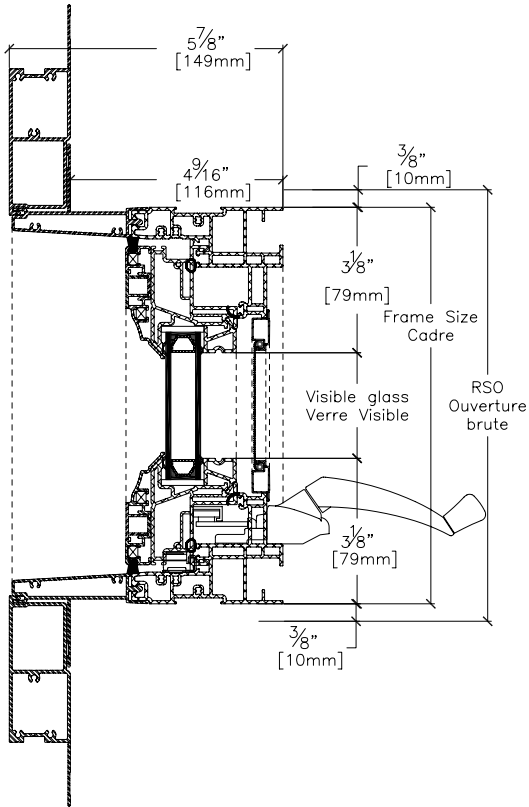

4 9/16" moulure 3 1/2" avec lame
 4 9/16" 3 1/2" brickmould with flange

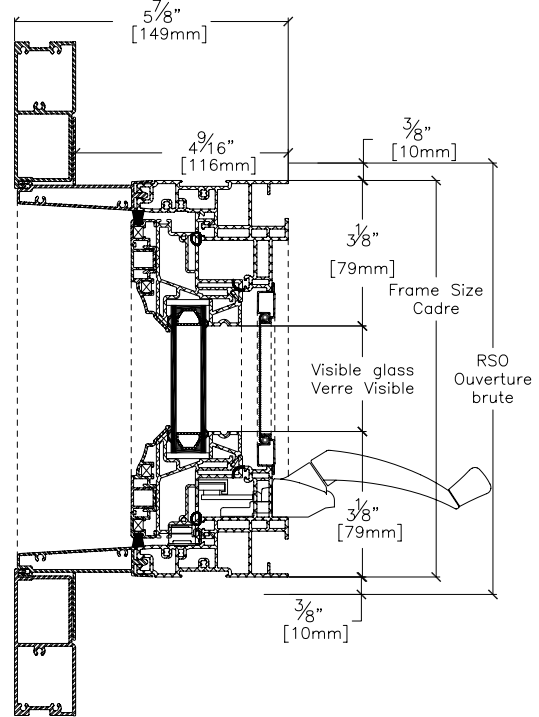

4 9/16" moulure 3 1/2" sans lame
 4 9/16" 3 1/2" brickmould without flange

90° CORNER MULLION

