

KENNARDS
HIRE

LIFTING SOLUTIONS FOR HIRE: ANYTIME, ANYWHERE!

Making light work of lifting solutions that are right for your project.

From large commercial construction and civil infrastructure developments through to smaller, tighter projects, we have the expertise to recommend a lifting solution that's right for you.



Cable Hauling



Glass Handling



Hoists & Winches



Lifting Plant & Equipment



Hydraulics

KEEP IT MOVING

> INDUSTRY SOLUTIONS > EXPERTISE > EASY >



WE'VE GOT YOUR SOLUTION

KENNARDS HIRE LIFT AND SHIFT

Our extensive range of lifting and materials handling will help you get any job done on large commercial construction and civil infrastructure developments. We can recommend the right lifting solution to achieve the safety, compliance and productivity goals for your project. Our range of hoisting, shifting, winching, hydraulic, and materials handling will make light work of all your lifting, shifting and moving requirements.

Our range is comprehensive and well maintained. Plus is backed by the benefits of being a part of the Kennards Hire group. We stock only leading, reputable brands with proven performance. Our highly trained staff understand your needs and we have convenient locations across Australia and New Zealand.

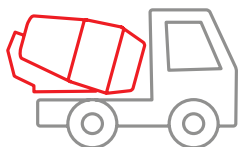

CONSTRUCTION

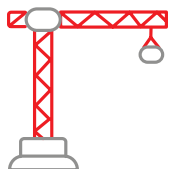

CRANES

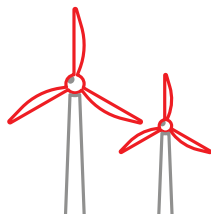

WIND & SOLAR



INFRASTRUCTURE



MINING



MAINTENANCE



LIFTING SOLUTIONS AND EXPERTISE

SOLUTIONS

Kennards Hire offers Tier 1 customers a comprehensive suite of solutions designed to elevate their operational efficiency and safety standards. Our commitment to safety is evident through our rigorous equipment maintenance protocols and adherence to industry best practices, ensuring that our clients can rely on our machinery without compromise.

Our team of experts, equipped with extensive industry knowledge, provides tailored advice and support to help clients select the most suitable equipment for their specific needs. Additionally, we continually invest in innovative technology and cutting-edge equipment, enabling our customers to leverage the latest advancements for optimal performance and productivity. By integrating safety, expertise, and innovation, Kennards Hire delivers unparalleled value and reliability to Tier 1 clients.

OUR EXPERTISE

Understanding your specific project needs is critical to recommending the right lift solutions. Our team of experts bring a combination of training, experience, and skills to recommend and activate lift solutions that achieve safety, compliance and productivity goals for your project.

We have a dedicated team of Lift and Shift Operations Product Specialists across Australia and New Zealand who will work alongside with your teams, engineers and contractors to ensure our equipment meets the targeted outcomes for your project along with the highest degree of safety.

A NEW LIFTING SOLUTION ON METRO TUNNEL PROJECT

Kennards Hire's Lift & Shift has partnered with Pacific Hoists to create a unique remote control system, allowing a 70-tonne load to be lowered into place as part of Melbourne's Metro Tunnel project.

The DC electric over pneumatic JUUKO remote system gives a single person instantaneous control over four air hoists - all at once or in any combination. Previously, each hoist would need to be operated by a different user, with critical delays of several seconds.

This ground-breaking system, created by Pacific Hoists, is now offered through Kennards Hire to customers requiring the most efficient, large-scale lifting solutions currently available.



CLICK OR SCAN
TO READ MORE





KENNARDS HIRE
SERIAL NO. 1106415

WLL12500KG
1106415
LIFTKET
KENNARDS HIRE

WLL12500KG

KENNARDS HIRE

HOISTS & WINCHES

CHAIN BLOCKS - ELECTRIC



DESCRIPTION

- Electric chain blocks ranging from 1T to 25T capacities.
- High duty cycle – up to 60%
- internal patented clutch system
- Wireless control on all hoists/trolleys
- Synchronization available
- Available in 1T – 25T capacities
- Chain lengths available up to 60M

SPECIFICATIONS

SWL	Power
1T	240V
2T	240V
3.2T	415V
6.3T	415V
12.5T	415V
25T	415V

GIRDER TROLLEY - POWERED



DESCRIPTION

- Aids in machinery positioning
- Assists with moving large loads
- Custom beam widths available
- Wireless control
- Powers directly from the hoist

SPECIFICATIONS

SWL	Power	Beam Width
1T/2T	240V	100mm – 310mm
3.2T/6.3T	415V	82mm – 310mm
6.3T/12.5T	415V	140mm – 310mm
12.5T	415V	140mm – 310mm
25T	415V	140mm – 310mm

AIR HOISTS



DESCRIPTION

- Use where electrical units are prohibited.
- 100% duty cycle
- Choice of pendant, rope control & wireless
- Chain lengths available up to 60M

SPECIFICATIONS

S.W.L	Air Consumption
1T	1.2 m3/min @ 6bar
2T	1.2 m3/min @ 6bar
3T	5.5 m3/min @ 6bar
6T	5.5 m3/min @ 6bar
12T	5.5 m3/min @ 6bar
16T	5.5 m3/min @ 6bar
20T	5.5 m3/min @ 6bar
30T	6.5 m3/min @ 6bar

HOISTS & WINCHES CONTINUED

CHAIN BLOCKS - MANUAL



DESCRIPTION

- Various length available
- Capacity to 20T
- Overload protection available

SPECIFICATIONS

SWL	Length
1T	3M, 6M, 12M, 18M, 24M
2T	3M, 6M, 12M
3T	3M, 6M, 12M
5T	3M, 6M, 12M
10T	6M, 12M
20T	6M

WINCHES - ELECTRIC



DESCRIPTION

- Portable and easy to use
- For lifting and pulling applications
- Wireless control available
- Various wire rope lengths
- Tirak winches for elevator installation

SPECIFICATIONS

Model	SWL	Rope Lengths	Weight
TR30	300kg	Up to 200M	25kg
TR50	500kg	Up to 200M	35kg
Tirak X1033P	1000kg (2T Sheaved)	Up to 150M	50kg
Tirak X2053P	2000kg (4T Sheaved)	Up to 150M	132kg

WINCHES - DRUM



DESCRIPTION

- Wireless remote with variable speed control
- Heavy duty cage with return sheave anchor point
- High capacity for both pulling and lifting
- Optional wire and 12 strand rope configurations
- Lengths up to 400M available depending on capacity

SPECIFICATIONS

Model	Capacity	Weight
CP-500	4.1T Pull, 500kg Lift	62kg
CWG-30565	9T Pull, 1.1T Lift	470kg
CWG-30750	18.3T Pull, 2.2T Lift	590kg
CWG-31500	29.1T Pull, 3.5T Lift	1075kg
CWG-34000	41T Pull, 5T Lift	1600kg

GANTRIES

GANTRIES



DESCRIPTION

- Provide portable lifting directly above
- Lightweight aluminium
- Range of beam lengths (2M-8M)
- Some models available for confined space entry

SPECIFICATIONS

Model	Capacity	Height Range*
Mini	1500kg	1.2M – 1.8M
Standard	1500kg	1.7M – 3M
Maxi	1500kg	2.3M – 4M
Mobile	1000kg	1.7M – 3M

SPECIFICATIONS

Model	Capacity	Height Range*
1T Reid	1000kg	2.1M – 2.8M
2T Reid	2000kg	2.1M – 3.1M
3T Reid	3000kg	2.8M – 4M
5T Reid	5000kg	2.8M – 4M

SPECIFICATIONS

Model	Capacity	Height Range*
10T Steel	10,000kg	2.8M – 4.2M
Beam lengths – 3M, 4M & 5M		

CRANE EQUIPMENT

PERSONNEL CRANE CAGES



DESCRIPTION

- Lifting people in a safe manner using a crane
- Designed in strict accordance with Australian Standards
- Multiple sizes available

SPECIFICATIONS

Capacity	S.W.L	Dimensions	Weight
1 Man	250kg	750x750mm	150kg
2 Man	500kg	1200x1100mm	310kg
4 Man	500kg	1200x1100mm	310kg
4 Man	750kg	2400x1200mm	500kg
6 Man	750kg	2400x1200mm	500kg
6 Man (QLD)	750kg	2900x1300mm	615kg



WLT 107

EAS WATER ENGINEERING

LIFTKET

OUTSIDE	FROM
SLAB EDGE	500MM
450MM	800MM
1750MM	2000MM
5000MM	2500MM
8000MM	2500MM
APPROX 1M FOR EACH PERSON	
GREATER THAN 1500MM	
FROM SLAB EDGE	

CRANE EQUIPMENT CONTINUED

CONCRETE KIBBLES



DESCRIPTION

- Designed for easy transfer and placement of materials
- Optional elephant chutes available for tighter access requirements
- Multiple sizes available

SPECIFICATIONS

Model	SWL	Dimensions (mm)	Weight
0.5 Cube	1500kg	1500L, 1630W, 1255H	275kg
1 Cube	3000kg	1705L, 1760W, 1655H	320kg
1.5 Cube	4000kg	1970L, 1850W, 1655H	415kg
2 Cube	5000kg	2760L, 1740W, 1910H	905kg

SPREADER BEAMS



DESCRIPTION

- All lifting applications that require controlled spread
- Fully AS/NZS compliant
- Multiple options and sizes available

SPECIFICATIONS

Model	SWL As spreader	Length	Weight (minus shackles)
Combi 5T	5T @ 60°	1.2M – 1.95M	40kg
Combi 8.6T	8.6T @ 60°	2.1M – 3.6M	76kg
Combi 10T	10T @ 60°	2.38M – 3.9M	260kg
Modular 12T	12T @ 60°	0.5M – 6.5M	120kg
Combi 15T	15T @ 60°	2.25M – 3.69M	95kg
Modular 24T	24T @ 60°	1M – 6M	180kg
Combi 30T	30T @ 60°	4M – 6M	260kg
Combi 50T	50T @ 60°	4M – 6M	360kg
Modular 60T	60T @ 60°	1.5M – 11M	941kg

LOAD CELLS / CRANE SCALES



DESCRIPTION

- Measuring applied loads for accuracy and safety purposes
- Wireless transmitter
- Lightweight and highly versatile

SPECIFICATIONS

Model	Capacity	Weight (Minus shackles)
1007215	2T	1.5kg
1007217	5T	1.8kg
1007220	6.5T	2kg
1007230	12T	4kg
9003237	25T	8kg
1007240	50T	15kg
9004651	55T	18kg
1007250	100T	34kg

TORQUE WRENCHES & HYDRAULICS

TORQUE WRENCHES - BATTERY



DESCRIPTION

- Range of features to provide safe, reliable & easy operation
- Digital display and simple programming for precise output
- Data transfer functionality
- Multiple ranges available

SPECIFICATIONS

Model	Torque Range	Drive	Tool Weight
EBT-72	200-1350Nm	3/4"	6.5kg
EBT-92	800-4000Nm	1"	8.7kg
EBT-119	1400-7000Nm	1.5"	13.9kg

TORQUE WRENCHES - HYDRAULIC



DESCRIPTION

- Allows for fast, calibrated tensioning and removal of nuts
- Compact & easy to use
- 360 degree swivel coupler

SPECIFICATIONS

Model	Torque Range	Drive	Tool Weight
TW1	183 - 1,837Nm	3/4"	2.5kg
TW3	451 - 4,512Nm	1"	5kg
TW5	752 - 7,528Nm	1.5"	8kg
TW8	1,078 - 10,780Nm	1.5"	11kg
TW10	1,551 - 15,516Nm	1.5"	15kg
TW25	3,472 - 34,725Nm	2.5"	35kg

Model	Torque Range	Hex Range	Tool Weight (approx.)
LPC2	232 - 2,414Nm	19-60mm	2.7kg
LPC4	585 - 6,474Nm	34-80mm	6.6kg
LPC8	1,094 - 11,774Nm	41-105mm	11.7kg
LPC30	4,188 - 44,593Nm	85-175mm	41.4kg

HYDRAULIC CYLINDERS/PUMPS



DESCRIPTION

- Wide range of hydraulic cylinders
- Large quantities available
- Tonnage from 5 to 500 Tonne
- Pumps available to 100 Litres
- Range of accessories, e.g. gauges, valves
- Tested to 700bar/10,000psi

HYDRAULIC SYNC LIFTING SYSTEM



DESCRIPTION

- Precise control of lifting and pushing
- Synchronisation up to 4 cylinders
- Ability to link control units enabling to manage up to 12 lift points
- Micro control technology
- Capable of control to millimetre accuracy across lift points
- LCD & Pendant control

GLASS HANDLING

VACUUM LIFTERS



DESCRIPTION

- Lifting and transporting of glass elements
- Range of vacuum lifters up to 1000kg
- Multiple configurations available

SPECIFICATIONS

Model	SWL	Weight
GL-N400/300	300kg	45kg
GL-LN400 - In-line	400kg	45kg
GL-600/800	600kg/800kg	60kg/80kg
GL-KN1000	1000kg	120kg

MOBILE GLASS LIFTERS



DESCRIPTION

- Versatile solution various glass installations
- Full head movement, rotation and side shift
- Multiple capacities available

SPECIFICATIONS

Model	SWL	Max Height (Centre of pads)	Weight
Winlet 350	350kg	2800mm	605kg
Winlet 575	575kg	3600mm	1410kg
Uplifter 625	625kg	4000mm	1050kg
Winlet 1000	1000kg	4100mm	1800kg

GLASS A FRAMES



DESCRIPTION

- Used for lifting & transporting glass sheets
- Forklift & crane compatible
- Various sizes available

SPECIFICATIONS

Model	SWL	Dimensions	Weight
OSA7247	2000kg	1878x1100x1600H	152kg
OSA7263	2000kg	1878x1100x2000H	169kg
STF2000	2000kg	2000x1705x2435H	348kg
STF3000	4000kg	3000x1705x2455H	466kg

HEIGHT SAFETY

CONFINED SPACE

DESCRIPTION

- For safe entry and exit when working in confined spaces
- Multiple options for confined space entry available
- Various mounting brackets & bases for davit systems
- Complies with AS/NZS standards





KENNARDS
HIRE

HILUX
2.8 D-4D

CABLE HAULING

WINCHES



DESCRIPTION

- For a wide range of cable hauling requirements
- Units set up for fibre optic & larger hauls
- Full operators dashboard with adjustment
- Tilt, capacity & speed control on trailer units

SPECIFICATIONS

Model	Capacity	Pull Wheel Size
Fibre optic - Trailer	5Kn - 510kg	500mm/1300mm
Winch - Trailer	30kn - 3000kg	250mm
Winch Skid	6.5T	200mm



DESCRIPTION

- High capacity diesel/hydraulic winch
- Hydraulic outriggers for quick, stable setup
- Heavy duty construction and mine compliant
- Remote foot control for flexible operation

SPECIFICATIONS

Model	Capacity	Pulling capacity
Trailer winch capstan	7000kg	70KN



CABLE HAULING

10T ADJUSTABLE - CABLE DRUM STAND



DESCRIPTION

- Heavy-duty drum stand designed to accommodate drums up to 10 tonnes
- Features adjustable end posts in 100mm increments
- Supplied as a bolted assembly for easy transport and storage
- Certified design
- Galvanised finish
- Foldable legs for access requirements

SPECIFICATIONS

Model	Length	Width	Weight
9005333	2520mm	2100mm	1250kg

JINKER TRAILERS



DESCRIPTION

- For transporting drums efficiently
- Outriggers for enabling control on uneven surfaces
- Battery & hydraulic control system
- Multiple sizes available

SPECIFICATIONS

Model	Capacity	Max Drum
9003387 MANUAL	1500kg	1800mm D – 1500mm W
1010950 BATTERY	2000kg	2200mm D - 1300mm W
9003327 DIESEL	2500kg	2600mm D - 1200mm W

CONT. CABLE HAULING EQUIPMENT



DESCRIPTION

- Cable crimpers & cutters to 60T
- Conduit rollers & guides
- Cable socks & swivels
- Cable jack stands
- Petrol and electric capstan winches
- Duct snakes
- Cable hauling rope

MATERIAL HANDLING

MATERIAL HOISTS – HEAVY DUTY



DESCRIPTION

- Heavy duty material hoists with increased lifting capacity
- Optional attachments for different lifting needs
- 3 Speed winch driven by cordless drill
- Compact design
- Removable counterweights
- Foldable legs for access requirements

SPECIFICATIONS

Model	SWL	Max Height	Weight
GML 800/25 CW	800kg	7.5M	665kg
GML800/15	650kg	4.7M	360kg
SLK25 CW	360kg	6M	229kg
SLK10 CW	450kg	3M	160kg

CRANES - TRACKED



DESCRIPTION

- No license needed
- Tracked pick and carry crane
- 990kg lifting capacity at 1.1M
- 1000kg deck carrying capacity
- 4.5M Reach
- Wireless remote control

SPECIFICATIONS

Model	Capacity	Size
AC2200	990kg	780 x 1525mm

FLOOR CRANE COUNTERWEIGHTED

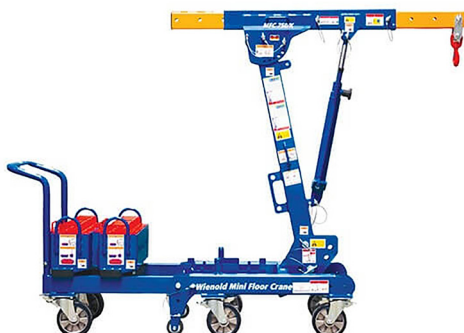

DESCRIPTION

- Versatile with a multi functional chassis
- Various configurations with counterweight placement
- Extendable boom

SPECIFICATIONS

Model	Capacity	Reach	Weight
MFC750	Max 900kg	1.28M +	160kg (650kg with weights)

MATERIAL HANDLING

PROPPING – SYSTEM 60 TONNE



DESCRIPTION

- High capacity modular system
- 60 Tonne (600kN) capacity vertical
- Multiple configurations & lengths

SPECIFICATIONS

Model	Max Capacity	Height Range
System 60	600kN (60 Tonne)	0.5M – 15M

PROPPING – HIGH LOAD

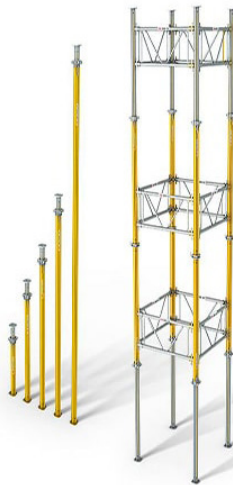

DESCRIPTION

- Lightweight aluminium construction
- Can be used in multiple configurations
- Safe, Easy Setup

SPECIFICATIONS

Model	Height Adjustment	Capacity Range
MP250	1.45 – 2.50M	75.5kN – 59.2kN
MP350	1.95 – 3.50M	91.0kN – 44.2kN
MP480	2.60 – 4.80M	88.5kN – 26.4kN
MP625	4.30 – 6.25M	57.9kN – 21.0kN



MATERIAL HANDLING

CONVEYORS



DESCRIPTION

- Portable and modular
- For sand, soil & rubble
- Works on slopes up to 33 degrees
- Lightweight aluminium body
- Fitted with emergency stop features

SPECIFICATIONS

Model	Power	Speed	Length
9002595	240V	Variable (Most models)	4.5M

TRACKED CARRIER



DESCRIPTION

- Bi-level function on some models
- Loading capacity of 2.5T
- Wireless control

SPECIFICATIONS

Capacity	Width	Height	Weight
2200kg	950mm	365mm	500kg

BATTERY PALLET TRUCKS



DESCRIPTION

- Battery powered with 2T capacity
- Inbuilt charger
- Anti collision device for operator safety

SPECIFICATIONS

Model	Capacity	Width
EPT20	2T	685mm

WHEELIE BIN LIFTERS – CAGED



DESCRIPTION

- Our range of bin lifters can accommodate a wide range of sizes
- Electro-hydraulic mechanism
- Simple, safe and easily controlled

SPECIFICATIONS

Model	Capacity	Tipping Height
1006692	150kg	1800mm
9003234	250kg	1800mm
9004653	600kg	1800mm

SPEAK TO AN EXPERT

NEW SOUTH WALES

LIFT AND SHIFT SILVERWATER

22 Fariola Street,
SILVERWATER NSW 2128

☎ 02 8753 7500

✉ LSSilverwater@kennards.com.au

ALEXANDRIA

5/53 Burrows Road
ALEXANDRIA NSW 2015

☎ 02 8594 4100

✉ LSAlexandria@kennards.com.au

QUEENSLAND

ROCKLEA

59 Balham Road,
ROCKLEA QLD 4106

☎ 07 3710 9444

✉ LSRocklea@kennards.com.au

VICTORIA

DANDENONG

1 Plunkett Road,
DANDENONG VIC 3175

☎ 03 8788 5000

✉ LSDandenong@kennards.com.au

PORT MELBOURNE

323 Williamstown Road,
PORT MELBOURNE VIC 3207

☎ 03 8420 6900

✉ LSPortMelbourne@kennards.com.au

SOUTH AUSTRALIA

HINDMARSH

2 Richard Street,
HINDMARSH SA 5007

☎ 08 8340 7000

✉ LSHindmarsh@kennards.com.au

WESTERN AUSTRALIA

BELMONT

198 Campbell Street,
BELMONT WA 6104

☎ 08 9478 2222

✉ LSBelmont@kennards.com.au

KARRATHA

LOT 1523 Lambert Road,
KARRATHA WA 6714

☎ 08 9144 6100

✉ karratha@kennards.com.au

NEW ZEALAND

EAST TAMAKI

131 Harris Rd,
EAST TAMAKI 2103

☎ 09 273 3129

✉ Liftandshiftauckland@kennardshire.com.au

WE ALSO STOCK A WIDE RANGE OF OTHER EQUIPMENT FOR HIRE, PROVIDING RELIABLE SOLUTIONS FOR A VARIETY OF JOBS.

- ✓ Goods Cages
- ✓ Forklift Attachments
- ✓ Snatch Blocks
- ✓ Lifting Chains
- ✓ Pallet Trucks
- ✓ Battery Pallet Trucks
- ✓ Magnetic Lifters
- ✓ Block Grabs
- ✓ Swift Lifts
- ✓ Skates
- ✓ Hydraulic Jacks
- ✓ Trolleys
- ✓ Conveyors
- ✓ Slings & Shackles
- ✓ Girder Clamps & Trolleys





CONNECT WITH US ON SOCIAL MEDIA

in [linkedin.com/company/kennardshire](https://www.linkedin.com/company/kennardshire)

f [facebook.com/kennardshire](https://www.facebook.com/kennardshire)

@kennardshire

▶ [youtube.com/user/kennardshire](https://www.youtube.com/user/kennardshire)



KEEP IT MOVING



CLICK OR SCAN TO
CONTACT YOUR LOCAL
KENNARDS HIRE
LIFTING SOLUTIONS
EXPERT



AU



NZ