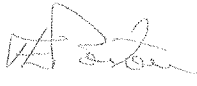

**MICHIGAN STATE**  
**U N I V E R S I T Y**

August 29, 2012

**MEMORANDUM**

**To:** Trustee Finance Committee

**From:** Fred L. Poston 

**Subject:** **Project Approval - Authorization to Proceed**  
College of Music's Community Music School - Renovations

**RECOMMENDATION**

BE IT RESOLVED that the Trustee Finance Committee recommends that the Board of Trustees authorize the Administration to proceed with the project entitled College of Music's Community Music School - Renovations, and to approve a budget of \$1,500,000.

**BACKGROUND**

**Program Need:**

The Community Music School offers opportunities for the study, appreciation, and therapeutic use of music while nurturing the musical development of all individuals. The school is the outreach division of the College of Music. The Community Music School currently occupies leased space at 841 Timberlane, East Lansing, Michigan, owned by the City of East Lansing School District. Michigan State University's lease ends November 30, 2012 and the school district has elected to sell the property.

A new site with the appropriate spaces and acoustical treatments is needed in order to continue the program activities of the school. The property at 4930 Hagadorn Road has been identified and acquired as the new site for the College of Music's Community Music School. The renovations to the space will support the program activities of the School including early childhood development, music therapy, and the seniors New Horizon Band.

**Description of the Project:**

The building is located at 4930 Hagadorn Road in East Lansing. This project involves installation of fire suppression for code compliance as a classroom facility; construction of practice spaces with acoustical treatments that include studios, classrooms for programs such as music therapy, percussion, and early childhood Suzuki; renovation of multi-purpose space for performances; modifications to the heating, ventilation, and air conditioning system as needed to accommodate the renovations; electrical, data, flooring, paint; and parking lot modifications for safety improvements.



OFFICE OF THE  
VICE PRESIDENT FOR  
FINANCE AND  
OPERATIONS

Fred L. Poston  
Vice President and  
Treasurer

Michigan State University  
Hannah Administration Building  
426 Auditorium Road, Room 412  
East Lansing, Michigan  
48824

Phone 517.355.5014  
Fax 517.353.6772  
[www.vpfo.msu.edu](http://www.vpfo.msu.edu)

The Design-Builder is Moore Trosper Construction Company.

Based on an assessment of the factors stated in the Project Planning and Approval process concerning Project Labor Agreements (PLA), the Vice President for Finance and Operations and Treasurer has determined that a PLA would not be required for this project.

**Communication Feedback:**

The campus community was given opportunities to provide feedback during the planning phase and any concerns have been addressed in the project design.

The Office of Campus Planning and Administration has reviewed this project and found it to be consistent with the Campus Master Plan and Planning Principles. The Campus Infrastructure Planning Work Group also supports the recommendation to proceed with the project.

As construction proceeds, the schedule will be reviewed with the campus community.

**Project Cost and Timetable:**

The budget for this Design-Build project is \$1,500,000, which is being funded by the general fund.

Construction is planned to begin in October 2012, with substantial completion in December 2012, and final completion by June 2013.

cc: R. Flinn, M. Haas, J. Kacos, G. Klein, B. Kranz, B. Latta, K. Lindahl,  
M. McCabe, J. Mumma, R. Nestle, D. Quinney, C. Reid

# Michigan State University Campus, East Lansing Alaiedon, Delhi, Lansing, and Meridian Townships

Ingham  
County

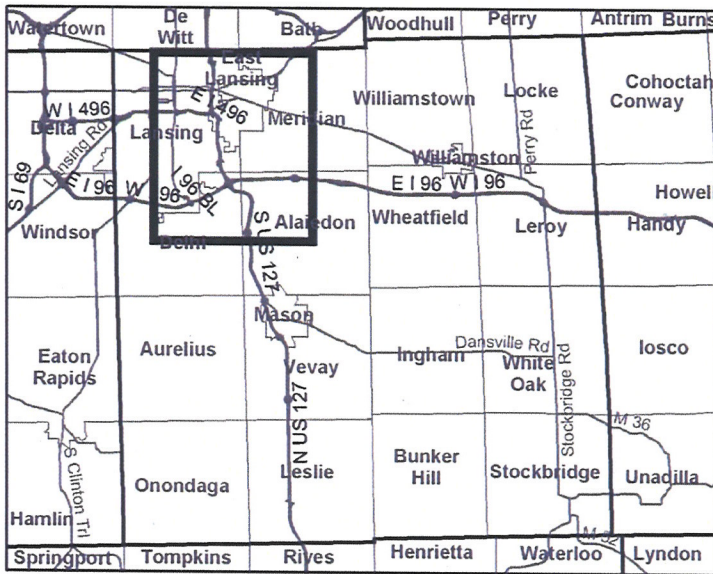

MSU Real Property

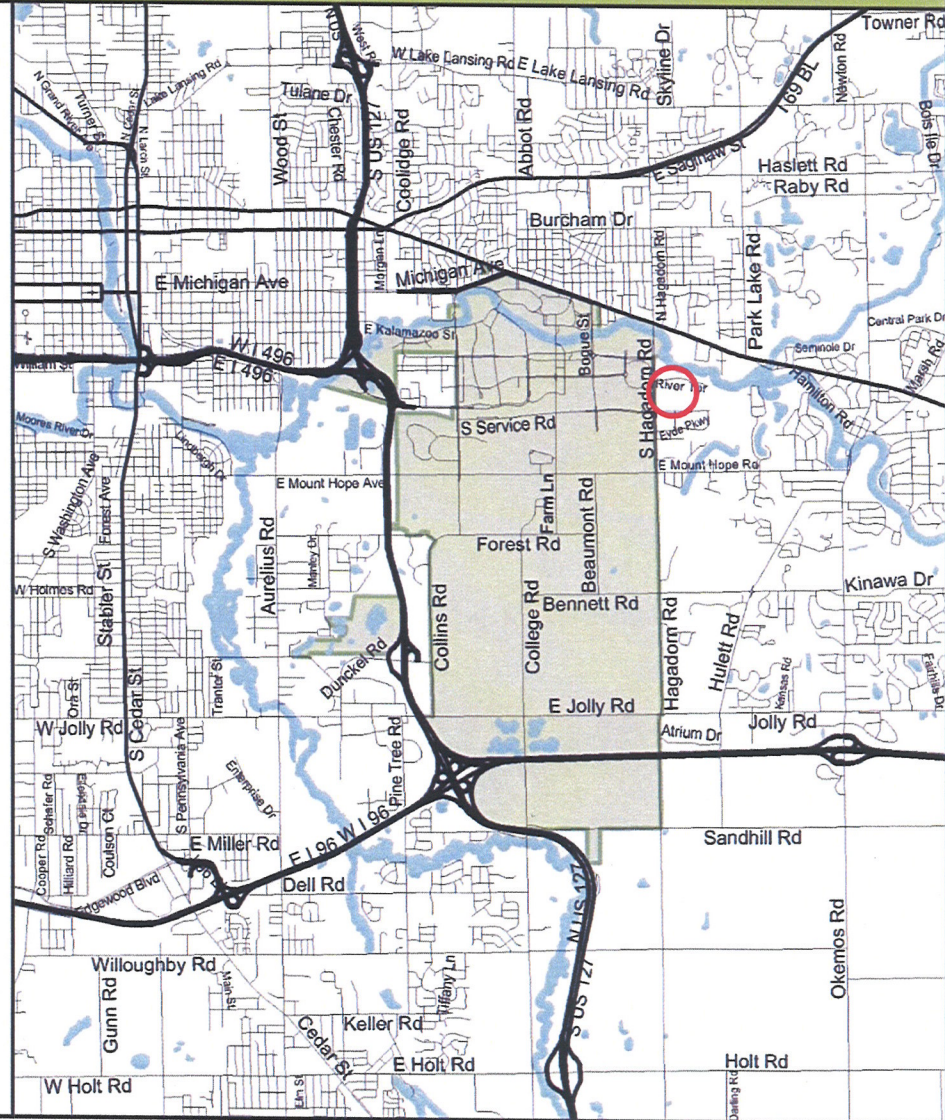

## University Reform Church Property

4930 & 4950 Hagadorn Road, East Lansing, MI 48823  
Meridian Township, Ingham County

Image Year: 2010



Project Approval – Authorization to Proceed  
 College of Music's Community Music School Renovation

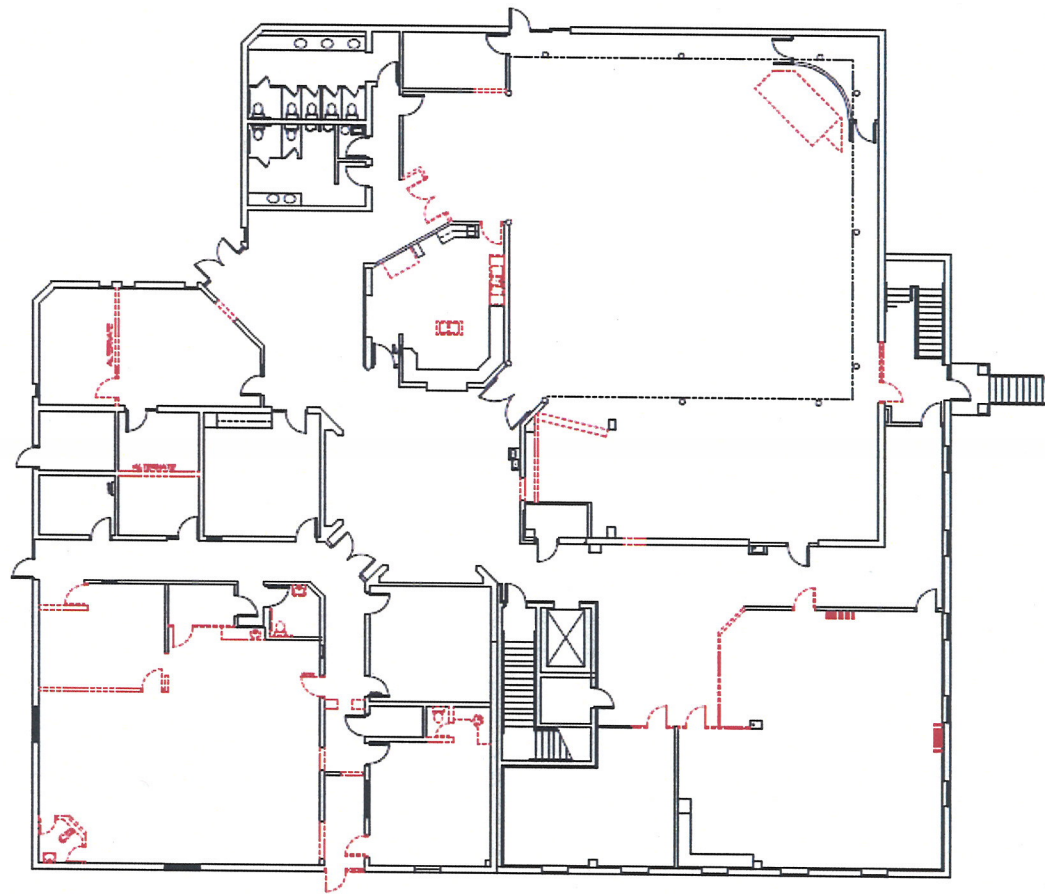

First Floor Demolition

DESIGN BY:  
 MBL INCORPORATED  
 ARCHITECTS

INTERIOR RENOVATIONS FOR  
 MSU Community Music School  
 480 S HADADEN ROAD  
 EAST LANSING, MICHIGAN



2245 Sargent Drive  
 East Lansing, Michigan 48824  
 (517) 335-7100 fax (517) 335-7143  
 pep@rockwood.com

		LATEST DATE FOR REVIEW FRI 20 JULY 2013	SHEET TITLE DEMOLITION FIRST FLOOR
		PROJECT NUMBER 12-39	SHEET NO. D-1

# Project Approval – Authorization to Proceed

## College of Music's Community Music School Renovation

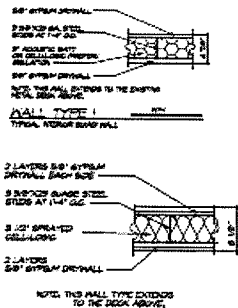
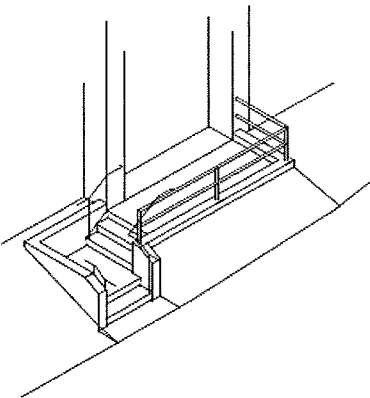
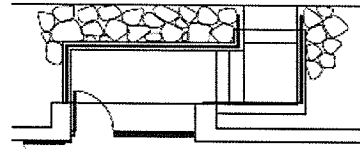

**WALL TYPE 2**  
SEE A RATED WALL CONSTRUCTION FOR ACHIEVING  
RESISTANCE BETWEEN ROOMS. SEAL ALL PENETRATIONS  
AND JOINTS, INCLUDING AT TOP AND BOTTOM TRACKS  
TO A WATER-TIGHT CONDITION.

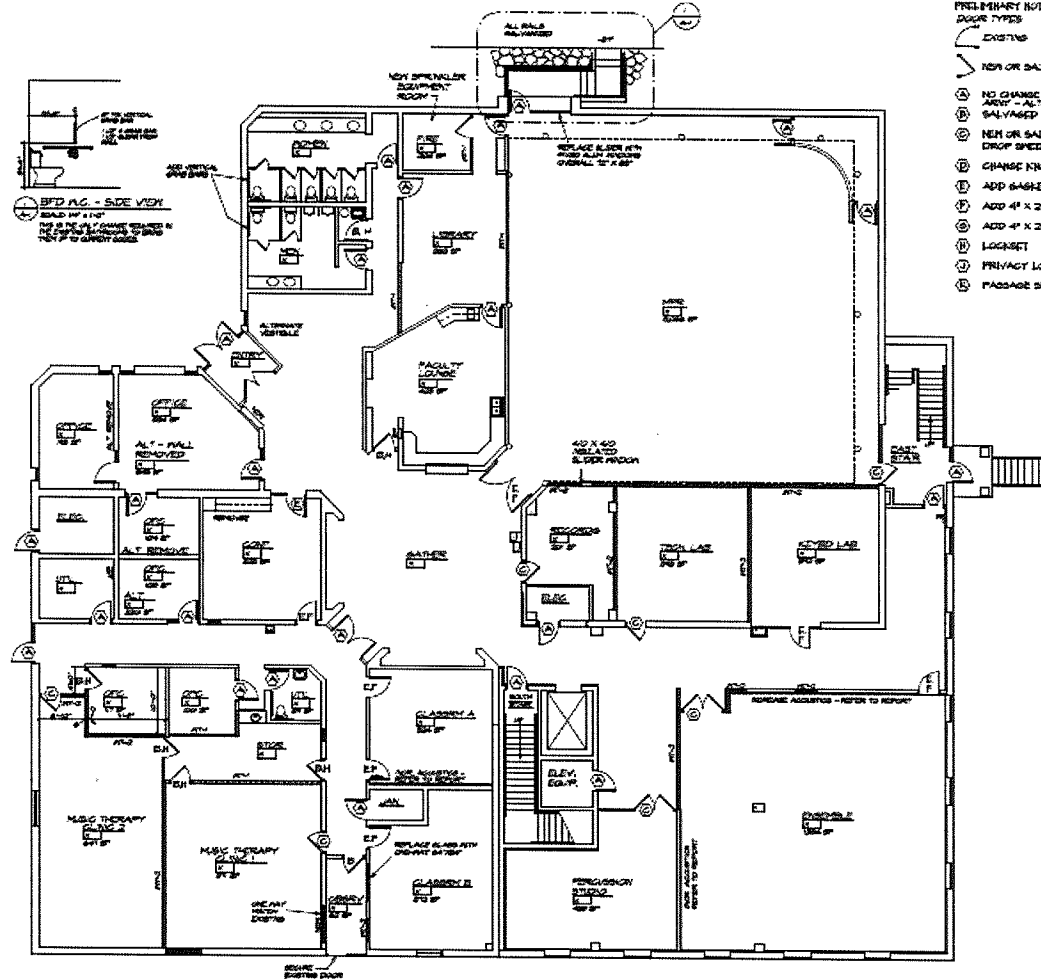

- PRELIMINARY NOTES - MAY 30 - JULY 2012
- DOOR TYPES
- EXISTING
  - NEW OR SALVAGED IN NEW LOCATION
  - NO CHANGE - VERIFY NOISE RATING, ADD SILENCE AREA - ALTERNATE TO REMOVE HARDWARE
  - SALVAGED DOOR, VERIFY FRAME
  - NEW OR SALVAGED 60 X 120 SC HOOD/REIN-FRAMEKIT/ DROP SPECTRUM/RELATED LIGHTGLASS/LOCASIT
  - CHANGE HINGE TO LEVER
  - ADD GASKET/DROP SILENCE
  - ADD 4" X 24" LITE IN INSULATED GLASS.
  - ADD 4" X 24" LITE 1/4" TO FORKED
  - LOCKSET
  - PRIVACY LOCKSET
  - PASSAGE SET

NO.	REVISION	DATE

**EAI**  
Engineering Applications  
E.A.I. LLC

**ROCKWELL DESIGN ARCHITECT**  
232 S. Jackson Drive  
East Lansing, Michigan 48824  
517-337-2823 Fax 517-337-4145  
info@rockwelldesign.com

PROJECT: INTERIOR RENOVATIONS FOR MSU Community Music School  
4400 S. HAGERDORN ROAD EAST LANSING, MICHIGAN

DATE: PREPARED: FIRST FLLOOR

PROJECT NAME: BSA 1206 PPHH 12-2012  
PROJECT DATE: 12/12/12  
DRAWN BY: BSA  
CHECKED BY: A-1  
**NOT FOR CONSTRUCTION**

First Floor Renovations

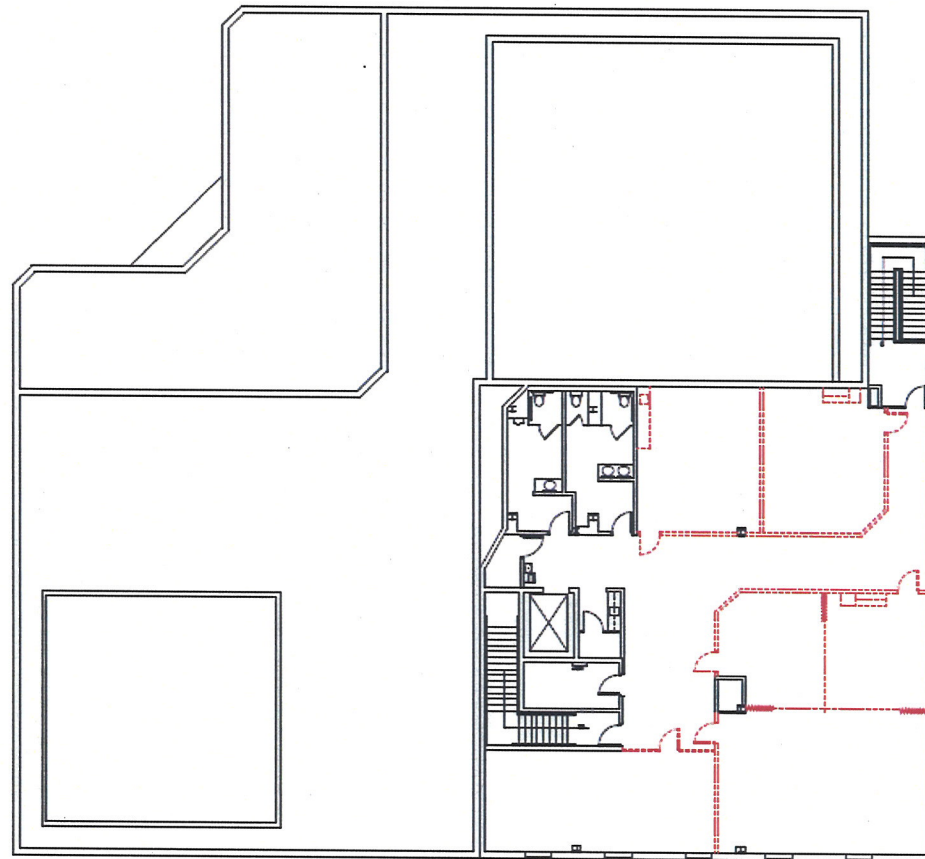

Second Floor Demolition

DRAWN BY:  
 DATE:  
 REVISIONS:  
 1. 12-31-12

INTERIOR RENOVATIONS FOR  
 MSU Community Music School  
 4900 S HAWGREN ROAD  
 EAST LANSING, MICHIGAN



East Lansing, Michigan 48824  
 (517) 270-5750 fax 517-494-1143  
 www.rockwooddesign.com

		LATEST DATE	SHEET TITLE
		DATE REVISION	DEMOLITION
		PROJECT NUMBER	SECOND FLOOR
		12-39	SHEET NO. D-2



**MICHIGAN STATE  
UNIVERSITY**

June 8, 2012

**MEMORANDUM**

**To:** Trustee Finance Committee

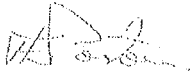
**From:** Fred L. Poston 

**Subject:** **Authorization to Plan**  
College of Music's Community Music School - Renovations



**RECOMMENDATION**

BE IT RESOLVED that the Trustee Finance Committee recommends that the Board of Trustees authorize the Administration to plan for the project entitled College of Music's Community Music School - Renovations.

**BACKGROUND**

**Program Need:**

The Community Music School offers opportunities for the study, appreciation, and therapeutic use of music while nurturing the musical development of all individuals. The school is the outreach division of the College of Music. The Community Music School currently occupies leased space at 841 Timberlane, East Lansing, Michigan, owned by the City of East Lansing School District. Michigan State University's lease ends November 30, 2012 and the school district has elected to sell the property.

A new site with the appropriate spaces and acoustical treatments is needed in order to continue the program activities of the school. The property at 4930 Hagadorn Road has been identified as a potential new site for the College of Music's Community Music School. After the Hagadorn Road property has been acquired, the renovations to the space will support the program activities of the School ranging from early childhood development, music therapy, and the seniors New Horizon Band.

**General Description of the Project:**

The planning of this project is anticipated to include installation of fire suppression for code compliance as a classroom facility; construction of practice spaces with acoustical treatments that include studios, classrooms for programs such as music therapy, percussion, and early childhood Suzuki; renovation of multi-purpose space for performances; modifications to the heating, ventilation, and air conditioning system as needed to accommodate the renovations; electrical, data, flooring, and paint.



OFFICE OF THE  
VICE PRESIDENT FOR  
FINANCE AND  
OPERATIONS

Fred L. Poston  
Vice President and  
Treasurer

Michigan State University  
Hannah Administration Building  
426 Auditorium Road, Room 412  
East Lansing, Michigan  
48824

Phone 517.355.5014  
Fax 517.353.6772  
www.vpfo.msu.edu

The Community Music School in East Lansing is anticipated to be located at 4930 Hagadorn Road, at the intersection of Shaw Lane.

Based on an assessment of the factors stated in the Project Planning and Approval process concerning Project Labor Agreements (PLA), the Vice President for Finance and Operations and Treasurer has determined that a PLA would not be required for this project.

**Communication Plan:**

During the planning phase, the campus community will be given opportunities to provide feedback on the project as it is being designed. Input from the project planning team will be solicited during the design phase.

**Preliminary Project Cost Information:**

Based on cost experience for similar projects and current pricing information, the preliminary project cost estimate is \$1,350,000. This estimate may change as planning progresses and the project scope is further defined.

The source of funds for the project is expected to be the general fund.

cc: R. Flinn, M. Haas, J. Kacos, G. Klein, B. Kranz, B. Latta, K. Lindahl,  
M. McCabe, J. Mumma, R. Nestle, D. Quinney, J. Forger, C. Reid

CP12900