



**DEPARTMENT OF ENVIRONMENTAL PROTECTION
BUREAU OF WATER & SEWER OPERATIONS**

**REVISED SUPPLEMENT TO THE NEW YORK STATE DEPARTMENT
OF HEALTH HANDBOOK FOR CROSS CONNECTION CONTROL**

This supplement was last revised on (6/10)

Introductory Note:

This supplement will help you prepare backflow prevention plans for submittal. It is a guide only and should not be used as a substitute for experience in the planning and design of backflow prevention device installations. If you are not experienced with this type of work, we suggest that you consult with a professional.

To avoid the expense and delay necessitated by the removal and reinstallation of containment devices, we suggest that you have your plans approved by DEP before proceeding with installation.

For new facilities, aesthetic considerations and architectural design is an unacceptable reason for granting exemptions. The architectural design must accommodate the containment devices, not the other way around.

Please note that the filing Professional Engineer or Registered Architect is expected to review the potential for hazard posed by the occupancy of the premises.

Based upon this review, the filing Professional Engineer or Registered Architect should select an appropriate containment device in accordance with the latest revision of the DEP Cross Connection Control Risk Assessment.

**OVERVIEW OF THE NYC ENVIRONMENTAL PROTECTION
CROSS-CONNECTION CONTROL PROGRAM**

For the Protection of the Water Supply System by Containment

WHO IS AFFECTED

Owners of properties that pose an actual or potential risk of contamination to New York City’s water supply. This includes property with any of, but not limited to, the following facilities:

* BAKERY	* AUTO BODY / REPAIR SHOPS
* BIDETS	* BEAUTY SALONS OR BARBER SHOPS
* CAR WASH	* BUTCHERS (INCLUDES FISH MARKETS & LIVE STOCK)
* CHEMICALS USED IN PROCESSING e.g. DYE PLANTS, PHOTO LABORATORIES	* CHEMICALLY TREATED BOILERS
* COMMERCIAL LAUNDRY FACILITIES WITH 2 OR MORE COIN OPERATED MACHINES	* DRY-CLEANING ESTABLISHMENTS
* DELICATESSEN /PREMISES WHERE FOOD IS BEING PREPARED	* COMMERCIAL KITCHENS / RESTAURANTS
* DENTAL OFFICES /LABORATORIES	* LARGE BOILERS (MORE THAN 350000 BTU)
* DISTILLED BREWERIES	* BOOSTER PUMPS
* FUNERAL PARLORS	* HOTELS AND/OR MOTELS
* GREENHOUSES	* GAS STATIONS AND/OR MINI MARTS WITH SODA MACHINES OR COFFEE LINES
* IN-GROUND IRRIGATION SPRINKLER	* HEAT EXCHANGERS WITH WATER (SINGLE WALL)
* WELLS (GROUNDWATER)	* PHARMACY
* MULTIPLE WATER SERVICES	* PRESSURE TANKS
* SEWAGE TREATMENT OR HANDLING	* PRIVATE WELLS
* VETERINARY OFFICES / LABORATORIES	* SWIMMING POOLS / COMMERCIAL SWIMMING POOLS
* WAREHOUSES (WITH TOXIC CHEMICALS STORAGE)	* METAL MANUFACTURING, CLEANING, PROCESSING OR FABRICATING PLANTS
* WATER REUSE / RECYCLING	* WATER COOLED EQUIPMENT OR CHILLERS
* MEDICAL OFFICES / LABORATORIES (INCLUDES PSYCHOLOGY & PSYCHIATRIC OFFICES THAT ADMINISTER MEDICATION)	* WATER STORAGE TANKS

WHAT LAW REQUIRES

Owners must install special plumbing devices, known as a backflow prevention device(s) on the water service pipes that supply their property. The device prevents water from flowing back into the City’s drinking water supply. Owners must obtain the approval of plans submitted to the Department of Environmental Protection (DEP) before installing the device and have the device tested by a state certified backflow-prevention device tester at least once a year. DEP’s Bureau of Water and Sewer Operations is charged with enforcing Part 5 Section 5-1.31 of the State Sanitary Code and Title 15, Chapter 20 of the Rules of the City of New York (RCNY).

HOW TO COMPLY

Step 1: A Professional Engineer (PE) or Registered Architect (RA) must prepare and submit two sets of plans and two applications originals (form GEN-236 New York City Version) for the installation of Backflow Prevention Device(s) to the Bureau of Water and Sewer Operations, Division of Permitting and Inspections for approval. All submissions must have original ink signatures and original ink or impression seals. Plans and applications must be corrected and resubmitted as necessary until acceptable.

Step 2: When the plans are approved, the Division of Permitting and Inspections issues a plan approval letter to the customer and returns one copy of the approved plans to the PE or RA of record.

Step 3: The device(s) must be:

- ❖ Installed by a New York City Licensed Master Plumber in accordance with the approved plans (installations must also meet the Building Department’s and the Bureau of Customer Service’s requirements).
- ❖ Tested by a State Certified Backflow Prevention Device Tester who is either a Licensed Master Plumber or employed by one.
- ❖ Inspected by a PE or RA and certified that they have found the installation to be in accordance with the approved plans.

Step 4: Finally, a completed “Report on Test and Maintenance of Backflow Prevention Device” (form GEN-215B), certifying the job, must be submitted to DEP within thirty days of installation of the device.

Step 5: Annual Inspection: At least once a year, the device must be inspected, maintained and tested, by a state certified tester. The results of the test must be reported to the department by filing Form GEN 215B with parts A & B properly completed.

Note: Be aware that some plumbers may provide “Turn Key” installation.

If you believe that your premise does not require a Backflow Prevention Device, you may have a Professional Engineer, Registered Architect, or Licensed Master Plumber submit a request for Exemption to the DEP Cross Connection Control Unit for consideration. If approved an exemption letter will be issued.

Steps for Installing Backflow Prevention Device

The following steps must be taken for the preparation, submission and approval of plans and the installation of backflow prevention devices for CONTAINMENT of facilities:

- Step 1: A Professional Engineer (PE) or Registered Architect (RA) must prepare and submit two sets of plans and two applications originals (form GEN 236 New York City Version) for the installation of Backflow Prevention Device to the Bureau of Water and Sewer Operations, Division of Permitting and Connections for approval. All submissions must have original ink signatures and original ink or impression seals. Plans and applications must be corrected and resubmitted as necessary until acceptable.
- Step 2: When the plans are approved, the Division of Permitting and Connections issues a plan approval letter to the customer and returns one copy of the approved plans to the PE or RA of record.
- Step 3: Device(s) must be:
- Installed by a New York City Licensed Master Plumber in accordance with the approved plans (installations must also meet the Building Department's and the Bureau of Customer Service's requirements)
 - Tested by a State certified Backflow Prevention Device Tester who is either a Licensed Master Plumber or employed by one
 - Inspected by a PE or RA and certified that they have found the installation to be in accordance with the approved plans.
- Step 4: Submit the "Report on Test Maintenance of Backflow Prevention Device" (Form GEN 215B), certifying the job to DEP within thirty days of device installation.

DEP will refer improper installations to the owner, PE or RA, or both. Improper installations must be corrected and re-certified (with Form GEN 215B) until acceptable. All installations are subject to inspection and verification.

Guidelines for Filling out Proposal of Backflow Prevention Device(s) Installation

General:

- Provide two sets of plans and two GEN 236 application forms bearing the original signature and seal of the applicant.
- All services of the same facility shall be protected and listed on the application.
- Backflow Prevention (BFP) Device(s) shall be NYS – DOH approved.
- No strainers are allowed between the water meter and the device. If required, strainer shall be approved type installed on the street side of the meter.
- No take offs are allowed on the street side of the device except approved combined services.
- Piping to be unbranched and unrestricted from main to device except for meter.
- The device shall be installed between the meter and the meter test tee.
- Meter test tee shall be capped or plugged.
- For RPZ and RPD devices where the proposed installation has to be below grade (i.e. Cellar or Basement), the applicant shall provide time calculations for full device failure up to the submersion of device discharge port. The time shall exceed 8 hours; otherwise, device(s) shall be installed above grade.
- Need to provide Elevation Plan, Floor Plan, Plot Plan, Engineering Report and notes.

Floor Plan

- Show a minimum of 30 in. clearance from the side of the device to the farthest wall or obstruction.
- Show a minimum of 8 in. clearance from the side of the device to the closest wall or obstruction.
- Show size of the meter.
- Plan view showing every BFP in conjunction with the water meter, test tee, meter inlet control valve (MICV) and meter outlet control valve (MOCV).
- Drainage details for RPZ's must be shown.

Elevation Plan:

- Provide a minimum of 30 in. clearance space from the centerline of device to floor.
- Provide a maximum of 60 in. clearance space from the centerline of device to floor.
- Provide a minimum clearance of 12 in. from the device to the ceiling.
- Air gap between the RPZ's relief port and the drain must be:
 - 2 in. air gap for device size of ¾ in. to 1 in.
 - 3 in. air gap for device size of 1 ¼ in. to 1 ½ in.
 - 4 in. air gap for device of 2 in. or larger
- If there is no gravity drainage, device shall be installed above grade. Sump Pump is not acceptable for gravity drainage.

Plot Plan:

- Show north arrow
- Show the size of water service
- Site plan for the entire facility must show the closed property line and labeling of all water service lines, mains, streets, location of BFP.

Notes:

- Print the drainage area in sq. ft. if you are installing in the basement or the cellar.
- If the BFP is installed more than 60 in. from the centerline above the floor, an OSHA approved platform, scaffold or ladder must be provided for maintenance and testing.

Between point of entry and BFP, the pipes must be stenciled "FEED TO BACKFLOW PREVENTER, DO NOT TAP OR CONNECT TO THIS LINE." at 5 ft intervals, and at all wall and floor penetration

APPLICATION FOR APPROVAL OF BACKFLOW PREVENTION DEVICES

[] FEE: \$350 PER SERVICE CONNECTION

PRINT OR TYPE ALL ENTRIES EXCEPT SIGNATURES

Please complete items 0 through 13.

		0. Block #	0a. Lot #	FOR DEPARTMENT USE ONLY				
1. Name of Facility:		2. County:	0b. Tentative Lot #					
3. Exact Location of Facility; i.e., Street Address:								
3a. City	3b. State New York	3c. Zip	4. Contact Person:	4a. Phone Number(s):				
5. Location of Device(s): (Attach additional sheets if required)				6. Manufacturer, Model No. and Size of Device(s):				
5a. # of Fire Services:	5b. # of Domestic Services:	5c. # of Combined Services:	5d. Total # of Services:	5e. Total # of Buildings:				
7. Name, Title & Phone No. of Property Owner: Full Mailing Address: _____ _____ _____			8. Type of Submission					
			[] As Built			[] Initial Device Installation		
			[] Replace Existing Device			8a. [] New Service		
			[] Existing Service			8b. [] New Building		
[] New Extension			[] Major Renovation					
[] Existing Building			Owner's Signature: _____ Date: _____					
9. Print Name and Address of Design Engineer or Architect: _____ _____ _____			10. NYS License #:					
			[] PE [] RA [] Other			10a. Telephone #:		
			10b. FAX #:			10c. Date:		
			Original Ink Signature & Seal Required on both copies.			11. Water System Pressure (psi) at Point of Connection: Max _____ Avg _____ Min _____		
			12. Estimated Installation cost:					

13. Degree of Hazard:		List of Processes or reasons which lead to degree of hazard checked:	
[] Hazardous			
[] Non-Hazardous with Hazardous Fixtures			
[] Aesthetically Objectionable			
14. Public Water Supply Name: NEW YORK CITY		Name of Supplier's Designated Representative:	
Mailing Address:		Daniel Chou	
NYC - DEP		Title: Cross-Connection Control Unit	
Bureau of Water & Sewer Operation		The degree of hazard shown in (13) above is in conformity with the latest DEP	
Cross-Connection Control Unit		Cross Connection Control Risk Assessment	
3rd Floor Low-Rise			
59-17 Junction Boulevard			
Flushing, NY 11373			
Telephone No.: (718) 595-5463		Signature:* _____ Date: _____	
Facsimile No.: (718) 595-5252		* Your signature endorses proposal	

NOTE: Two copies of this form and two copies of all plans, specifications and supporting materials must be submitted to: New York City, Department of Environmental Protection, Bureau of Water & Sewer Operations, Cross-Connection Control Unit, 3rd Floor Low-Rise, 59-17 Junction Boulevard, Flushing, NY 11373.

INSTRUCTION FOR FORM GEN 236 (NYC VERSION)
APPLICATION FOR APPROVAL OF BACKFLOW PREVENTION DEVICES

- 0 to 4a) Fill in as appropriate. Be sure to include the block and lot numbers.
- 5) Be as specific as possible. (e.g. “8’ N of Elm Street and 12’ South of Main Street”)
- 5a, b, c) Fill in the number of services for the entire facility.
- 5d) This is the total of 5 a, b, and c.
- 5e) Fill in the total number of buildings in the facility. All adjacent buildings under the same ownership, occupancy or operation are considered part of the facility. Distant buildings with the same water, heating or other shared, common or interconnected systems are considered part of the same facility. If you have doubts or uncertainties, feel free to elaborate at length on additional sheets.
- 6) Note Manufacturer, model & size of each device.
- 7) Indicate name, mailing address & phone number of property owner. Be sure this information is current. Failure to provide correct property owner mailing address will result in delayed notification.
Be sure to use original ink seal & signatures on both originals.
- 8, a, b) Check the applicable boxes
- 9) Print name & company (if any) of the design engineer or architect. (Do not use the name of the firm in place of the P.E.’s or R.A.’s name). Fill in the complete mailing address.
Be sure to use original ink seals & sign on both originals.
- 10) Include NYS License number in blank. Check appropriate category.
- 10 a, b) Be sure to enter all applicable phone/fax numbers.
- 10c) Enter date application is signed.
- 11) Make sure that water system pressure at point of connection is included.
- 12) Be sure to include these estimates. No blanks permitted. Use fair market value if you are working for free.
- 13) Choose one of the Degree of Hazard and list the reasons. If you decided to choose Double Check Valve Assembly (DCVA), you are required to give the proper reasons.
- 14) To be completed by Water Supplier.

If you need additional space, use the back or attach additional sheets. If so, please indicate “Continued on back” or “See Additional Sheets” as appropriate.

Definitions for Commonly Used Cross-Connection Terms

AFF – Above finished floor.

Airgap – means the unobstructed vertical distance through the free atmosphere between the lowest opening from a pipe, RPZ discharge port, drain line or faucet supplying water to a tank, plumbing fixture floor drain, or any other device. This approved airgap shall be at least double the diameter of the supply pipe, measured vertically, above the overflow of the vessel; and in no case less than one inch. For RPZ's, an airgap may be based on twice the effective diameter of the relief port.

Airgap Fitting – is a manufactured device which fits on the RPZ's discharge port and is designed to serve as an airgap. When a manufacturer's airgap fitting is used and a drain pipe carries the relief port discharge to a drain or sewer, an additional free atmosphere airgap is needed between the end of the relief port discharge pipe and the drain or sewer opening.

Acceptable Backflow Prevention Device – is an acceptable airgap, approved reduced pressure zone device (RPZ), or approved double check valve (DCV, DCVA). Approved devices are those that are listed by The New York State Department of Health.

Aesthetically Objectionable – refers to substances (e.g. stagnant water, hot water) which if introduced into the water supply system, could be a nuisance to other water customers but would not adversely affect human health.

Approved Device – RPZ or DCV, which has been listed by The New York State Department of Health as an acceptable backflow prevention device. Others are not acceptable.

Backflow – The reversal of the normal flow of water caused by either backpressure or backsiphonage.

Containment – the means which isolate customers' entire facility from the public water system so as to provide the protection necessary to prevent contamination of the public water supply in the event of contamination within the customers' facilities.

DCV – double check valve, device with two single, independently acting check valves, including tightly closing shutoff valves located at each end of the assembly and suitable connections for testing the watertightness of each check valve, and listed by the New York State Department of Health.

Hazardous Facility – is one in which substances may be present which if introduced into the public water system would or may endanger or have an adverse effect on the health of other water customers.

Horizontal Alignment - the distance from the middle of the device to the nearest front or back wall, and the distance to the nearest side wall. (In some cases, reference can be made to a column, curb, or some fixed conspicuous object).

MOCV – Meter Outlet Control Valve, the line valve that is used in conjunction with the test tee to test the meter. This valve shall be located on the house side of the test tee in order to prevent water flow to and from the facility during meter testing.

RPZ – Reduced Pressure Zone Backflow Prevention Device. A device containing two independently acting check valves on both sides of an automatically operated pressure differential relief valve, all located between two resilient seated shutoff valves. Acceptable devices must be listed by the New York State Department of Health.

Side Clearance – is the clear horizontal distance between the side of the device to the nearest side wall (i.e. wall parallel to the water flow).

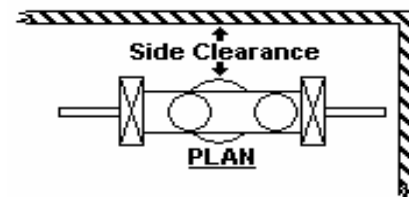

Test Tee – a tee used for testing the meter.

Vertical Position – distance above the finished floor AND the

INSTRUCTION FOR COMPLETION OF
“Report on Test and Maintenance of Backflow Prevention Device”
(FORM GEN-215B)

Use a separate form for each device

Initial Test and Certification: complete all 4 parts

Annual Re-Certification: complete parts A and B only

Part A: To be completed in ALL cases:

Part B: Certified Backflow Prevention Device Tester must fill out this portion in All cases:

- Be sure to answer Question 1. If the answer is “YES”, explain in the space provided. A connection for a properly installed and certified parallel device should not be construed as a connection. Hose cocks and spigots must be considered as connections. Tees must be considered as outlets unless they have been PERMANENTLY plugged or sealed. (Tees may be plugged by welding on blank flanges or by screwing in a plug and cutting the plug off flush with the face of the tee). Plugged tees will only be acceptable for old work. Tees on the street side of the backflow prevention device will not be allowed on new jobs. Risers, feeds to boilers and the like must be construed as connections.
- Indicate INITIAL TEST or Re-CERTIFICATION
- Clearly print, type or rubber stamp: Name, Certified Tester # and Certified Tester Expiration Date
- Include the line pressure (taken at number 1 test cock with shutoff valve number 1 closed)
- Include the pressure drop across the first check valve (the pressure differential between the second and the third test cocks).
- Completion time of test refers to the time of day (e.g. 8:00 am).
- If there is no water meter, indicate this on the form.

Part C: Complete For INITIAL TEST Only!

- The Professional Engineer or Registered Architect (PE/RA) must complete Part C.
- Be sure to fill in the **“Water Supplier Approval #”**
- Indicate whether you are the designer of record or not
- Indicate minor changes if there are any. Use back or additional pages as required.
- Indicate “See Back” or “See Additional Pages” as appropriate. If a device different than the approved device is used, the PE or RA must specify that the submission is acceptable and will not cause any adverse hydraulic effects
- If the installation changes meet DEP requirements while deviating from the approved plans, the job may be resubmitted for re-approval or an As-built Record Drawing may be submitted
- When the installation deviates from the approved plans and required minimums are not satisfied, the job should NOT be certified.

Part D: The Professional Licensed Master Plumber must complete Part D

- Be sure to fill in the Building Department Number (ARA #, ALT#, NB#, etc). Use of sticker is preferred.
- Indicate if you are the Licensed Master Plumber of record or not
- Indicate Licensed Master Plumber’s Name. Licensed Master Plumber’s License #. Licensed Master Plumber’s Telephone Number. Use Original Ink Signature Raised Impression Seal of Licensed Master Plumber & Date

*The Tester, the PE or RA & the Licensed Master Plumber should all sign the same form for each particular device.
 For each of the completed forms, USE ORIGINAL INK SIGNATURES & ORIGINAL INK OR RAISED IMPRESSION SEALS.*

Mail one completed Form to:
 Department of Environmental Protection
 Division of Permitting & Inspections
 Cross Connection Control Unit
 59-17 Junction Boulevard, 3rd Fl. Low-Rise Flushing, NY 11373

ACCEPTABLE DOUBLE CHECK VALVE (DCV) ASSEMBLIES

COMPANY	MODEL SERIES	SIZE (IN INCHES)											
		0.50	0.75	1.00	1.25	1.50	2.00	2.50	3.00	4.00	6.00	8.00	10.00
AMES	2000SS							H+V↑	H+V↑	H+V↑	H+V↑	H	H
	2000B	H+V↑	H+V↑	H	H+V↑	H+V↑	H+V↑						
	COLT200a							H+V↑	H+V↑	H+V↑			
	MAXIM200a							H+V↑	H+V↑				
	COLT200Na							H↑i↓o	H↑i↓o	H↑i↓o			
MAXIM200Na							H↑i↓o	H↑i↓o					
BUCKNER	24100		H	H	H	H	H						
CLA-VAL	D-2		H	H	H	H							
	D-4						H	H	H	H	H	H	H
	DC6LW		H+V↑	H		H	H						
	DC7L (W/Y)							H	H+V↑	H+V↑	H+V↑	H	H
	DC8L (W/Y)									H+V↑	H+V↑	H+V↑	
	DC8N (W/Y)							N	N	N↑	N↑	N	
DC8V (W/Y)							Z	Z	Z	Z	Z		
CONBRACO	40-100		H	H		H	H	H	H	H	H	H	H
	4SG-100							H+V↑	H+V↑	H+V↑	H+V↑	H+V↑	
	4SG-100U							H↑i↓o	H↑i↓o	H↑i↓o	H↑i↓o	H↑i↓o	
	DC (aka 4S-100)	H+V↑						H+V↑	H+V↑	H+V↑	H+V↑	H+V↑	H+V↑
	40-106-A2				H								
40-106-997				H									
FEBCO	805 YD							H	H+V↑	H+V↑	H+V↑	H	H
	850	H+V↑	H+V↑	H+V↑	H+V↑	H+V↑	H+V↑	H+V↑	H+V↑	H+V↑	H+V↑		
	870									H+V↑	H+V↑	H	
	870V									H+V↑	H+V↑	H+V↑	
	870 -N SHAPE							H	H				H
870V- Z SHAPE							H	H					
FLOMATIC	DCVE		H	H		H	H						
	DCV		H	H			H	H	H	H	H	H	
HERSEY/ GRINNEL	NO. 2								H	H	H	H	H
	FDC		H			H	H						
	HDC		H	H		H	H						
KENNEDY	1373									H	H	H	H
ORION	BDC		H	H		H	H		H	H			
WATTS	007	H+V↑	H↑i↓o	H↑i↓o		H↑i↓o	H↑i↓o	H↑i↓o	H↑i↓o				
	007MIQT			H↑			H↑						
	007M2QT				H+V↑	H+V↑							
	007M3QT		H			H							
	709							H↑i↓o	H↑i↓o	H↑i↓o	H+V↑	H+V↑	H+V↑
	719QT					H	H						
	719AQT					H							
	U719QT					H							
	774							H	H	H+V↑	H+V↑	H+V↑	H
	757							H+V	H+V	H+V	H+V	H	H+V
757a							H+V↑	H+V↑	H+V↑	H+V↑			
757Na							H↑i↓o	H↑i↓o	H↑i↓o	H↑i↓o			
WILKINS	350							H+V↑	H+V↑	H+V↑	H+V↑	H+V↑	H+V↑
	350A							H	H	H+V↑	H+V↑	H+V↑	
	950XL		H+V↑	H	H	H	H						
	950XL OS&Y					H	H						
	950XLT		H	H									
	950XLU		H	H		H	H						
450							H↑i↓o	H↑i↓o	H↑i↓o	H↑i↓o	H↑i↓o	H↑i↓o	

ACCEPTABLE REDUCED PRESSURE ZONE (RPZ) DEVICES

COMPANY	MODEL SERIES	SIZE (IN INCHES)													
		0.25	0.375	0.50	0.75	1.00	1.25	1.50	2.00	2.50	3.00	4.00	6.00	8.00	10.00
AMES	4000SS									H	H	H	H		
	4000B			H	H	H	H	H	H						
	4000BM2					H									
	Colt400									H	H	H			
	Maxim400									H	H				
	Colt400N									H↑↓	H↑↓	H↑↓			
	Colt400Z									H↑↓	H↑↓	H↑↓			
	Maxim400N									H↑↓	H↑↓				
Maxim400Z									H↑↓	H↑↓					
BUCKNER	24000				H	H	H	H	H						
CLA-VAL	RP-2				H	H	H	H							
	RP-4								H	H	H	H	H	H	H
	RP-4V											H			
	RP6LW				H	H	H	H	H						
	RP6VW				H	H		H	H						
	RP7L (W/Y)									H	H	H	H	H	H
	RP8L (W/Y)									H		H	H	H	H
	RP8N (W/Y)										N	N	N	N	N
RP8V (W/Y)										Z	Z	Z	Z	Z	Z
CONBRACO	40-200	H	H	H	H	H	H	H	H	H	H	H	H	H	H
	40-200A2S				H	H									
FEBCO	825 Y				H	H	H	H	H						
	825 YA				H	H		H	H						
	825 YD									H	H	H	H	H	H
	860			H	H	H	H	H	H	H	H	H	H	H	H
	880-N									H	H	H	H	H	H
	880V-Z									H	H	H	H	H	H
FLOMATIC	RPZIE			H	H										
	RPZE				H	H		H	H						
	RPZ				H	H	H	H	H	H	H	H	H	H	
	RPZII			H	H										
HERSEY/ GRINNEL	6CM									H	H	H	H	H	H
	FRP-2				H	H	H	H	H						
ORION	BRP				H	H		H	H		H	H			
WATTS	U009				H	H		H	H						
	009				H	H		H	H						
	009QT	H	H	H						H	H				
	U009QT				H										
	909				H	H	H	H	H	H	H	H	H	H	H
	909QT				H+V↑	H+V↑									
	909M1QT						H	H	H						
	919QT				H+V↓	H+V↓	H+V↓	H+V↓	H+V↓						
	957									H	H	H			
	957N									H↑↓	H↑↓	H↑↓			
	957Z									H↑↓	H↑↓	H↑↓			
	U009M2AQT					H		H	H						
	009M2QT					H	H	H	H						
	009M3QT				H										
994									H	H	H	H			
WILKINS	375				H	H				H	H	H	H	H	H
	375A											H	H	H	
	475									H↑↓	H↑↓	H↑↓	H↑↓	H↑↓	
	475V									H↑↓	H↑↓	H↑↓	H↑↓	H↑↓	
	975XL	H	H	H	H	H	H	H	H						
	975XLV				H↑↓	H↑↓									
	975XLU				H	H		H	H						
	975XLMS				H	H	H	H	H						
	975XLBMS				H	H	H	H	H						
	975XLSE				H↑↓↑	H↑↓↑	H↑↓↑	H↑↓↑	H↑↓↑						
	975XLSEU				H↑↓	H↑↓	H↑↓	H↑↓	H↑↓						

ACCEPTABLE DOUBLE CHECK DETECTOR (DCD) ASSEMBLIES

COMPANY	MODEL SERIES	SIZE (IN INCHES)											
		0.50	0.75	1.00	1.25	1.50	2.00	2.50	3.00	4.00	6.00	8.00	10.00
AMES	C300									H			
	3000 SE							H			H+V↑**	H+V↑**	
	3000 SS							H+V↑**	H+V↑**	H+V↑**	H+V↑**	H	H
	3000B						H						
CLA-VAL	DD7LY								H*	H+V↑*	H+V↑*	H*	H*
	DD8LY									H+V↑*	H+V↑*	H+V↑*	
	DD8NY- N									H+V↑	H+V↑	H*	
	DD8VY - Z									H	H	H	
CONBRACO	40-600								H*	H*	H*	H*	H*
	DCDA (aka 4S-600)							H+V↑	H+V↑	H+V↑	H+V↑	H+V↑	H+V↑
	4SG-600							H+V↑	H+V↑	H+V↑	H+V↑	H+V↑	
	4SG-600U							↑↓V	↑↓V	↑↓V	↑↓V	↑↓V	
FEBCO	806 YD								H*	H+V↑**	H+V↑**	H**	H**
	856							H	H	H+V↑**	H+V↑**	H+V↑**	
	876							H	H	H+V↑**	H+V↑**	H**	H
	876V							H	H	H+V↑**	H+V↑**	H+V↑**	
HERSEY/ GRINNEL	DDC-II								H**	H**	H**	H**	H**
WATTS	007 DCDA						H+V↑**	H+V↑**	H*				
	709 DCDA								H↑↓o**	H↑↓o**	H+V↑*	H+V↑*	H+V↑*
	757							H+V	H+V	H+V	H+V	H	H+V
	757A							H+V↑	H+V↑		H+V↑		
	774 DCDA								H	H+V↑	H+V↑	H	H
	757a-DCDA-BF							H+V↑	H+V↑	H+V↑			
WILKINS	757a-DCDA-GV							H+V↑	H+V↑	H+V↑			
	350DA							H+V↑	H+V↑	H+V↑	H+V↑	H+V↑	H+V↑
	350ADA							H+V↑	H+V↑	H+V↑	H+V↑	H+V↑	
	450DA									H↑↓o	H↑↓o		

ACCEPTABLE REDUCED PRESSURE DETECTOR (RPD) ASSEMBLIES

COMPANY	MODEL SERIES	SIZE (IN INCHES)													
		0.25	0.375	0.50	0.75	1.00	1.25	1.50	2.00	2.50	3.00	4.00	6.00	8.00	10.00
AMES	5000CIV									H	H	H	H	H	H
CLA-VAL	18														H*
	RD7LY									H*	H*	H*	H*	H*	H*
CONBRACO	40-700										H*	H*	H*	H*	
FEBCO	826YD									H*	H**	H**	H**	H**	H**
HERSEY/ GRINNEL	6CM RPDA										H*	H*	H*	H*	
WATTS	909 RPDA									H	H**	H**	H**	H**	H**
WILKINS	375DA									H	H	H	H	H	
	375ADA									H	H	H	H	H	H
	475DA											H↑↓o	H↑↓o		
	475DAV											H↑↓o		H↑↓o	

NOTES:

- * - These devices are acceptable as Backflow Prevention Devices, check with the Bureau of Water & Energy Conservation for acceptability as Detector Checks.
- ** - These devices are acceptable as Detector Checks by the Bureau of Water & Energy Conservation as of June 7, 1994.
- H - Horizontal installation
- ↑ - Vertical installation (flow up) (W/Y) - Non-rising stem and outside stem & yoke, respectively
- ↓ - Vertical installation (flow down) N - "N" Configuration: refer to manufacturer's literature II -4" x 4" x 8" Manifold"
- ↑↓o - Vertical up inlet and vertical down outlet Z - "Z" Configuration: refer to manufacturer's literature III -6" x 6" x 10" Manifold"

SOURCES: New York Department of Health, Office of Public Health, Center for Environmental Health, Environmental Health Manual, Alicia Spencer Technical Reference, Item No. PWS 14, Dated: 04/15/94 & Supplements 05/03/94, 11/22/94, & 7/17/95; 6/26/97; 10/15/98; 3/10/99; 7/21/99; 1/27/00; 5/10/00; NYC DEP Bureau of Water & Energy Conservation, Water Meter Approval List, Dated: 06/07/94.



**DEPARTMENT OF ENVIRONMENTAL PROTECTION
BUREAU OF WATER AND SEWER OPERATIONS**

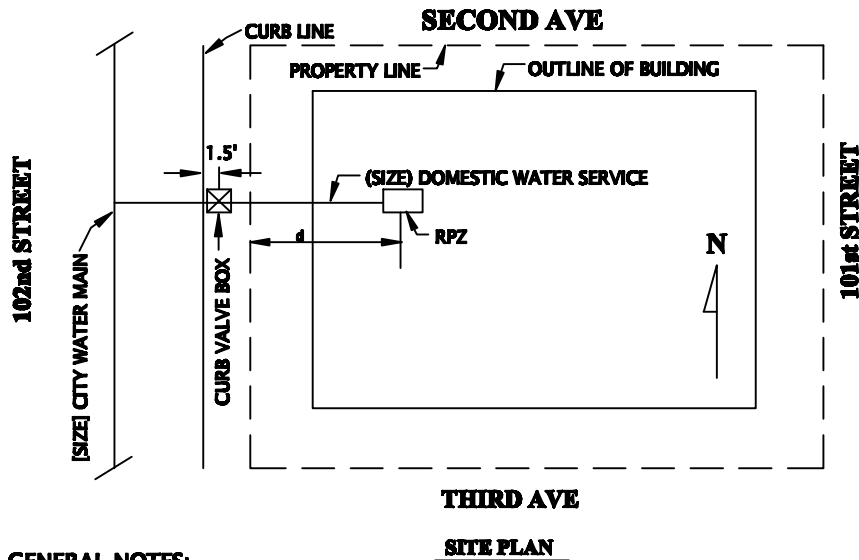

GENERAL NOTES:

1. THE INSTALLATION OF BFP SHALL MEET ALL NYC DEP CROSS-CONNECTION CONTROL UNIT AND NYS DOH REQUIREMENTS.
2. UNLAWFUL TO REMOVE THIS DEVICE FOR ANY REASON UNLESS DEP IS NOTIFIED.
3. EACH BFP DEVICE SHALL BE TESTED ANNUALLY BY NEW YORK STATE CERTIFIED TESTER.
4. ROOM WHERE BFP DEVICE IS TO BE LOCATED HAS HEATING AND LIGHTING.
5. THE PE/RA IS RESPONSIBLE FOR CHECKING THAT THE DEVICE IS INSTALLED ACCORDING TO APPROVED PLAN AND SIGNING THE CERTIFICATION STATEMENT ON FORM GEN 215B.
6. BETWEEN POINT OF ENTRY AND BFP, PIPES MUST BE STENCILED " FEED TO BACKFLOW PREVENTER. DO NOT TAP OR CONNECT TO THIS LINE" AT 5' INTERVALS, AND AT ALL WALL AND FLOOR PENETRATIONS.
7. CALCULATE TIME FOR FULL DEVICE FAILURE TO SUBMERSION OF DEVICE DISCHARGE PORT (DETAILED), MUST EXCEED 8 HOURS. OTHERWISE DEVICE MUST BE INSTALLED ABOVE GRADE.

DETAIL NOTES:

1. SPECIFY SIZE & TYPE OF METER.
2. SPECIFY SIZE & MODEL OF RPZ.
3. SEE TEXT FOR ADDITIONAL REQUIREMENTS.
4. SHOW DIRECTION OF THE FLOW IN ALL VIEWS.
5. TEST TEE MAY FACE UP, DOWN OR SIDWAYS. TEST TEE MUST BE CAPPED OR PLUGGED.
6. FIVE (5) TIMES PIPE DIAMETER (MINIMUM).
7. THREE (3) TIMES PIPE DIAMETER (MINIMUM).
8. THIRTY (30) INCH MINIMUM CLEARANCE SPACE FROM SIDE OF DEVICE TO FARTHER WALL OR OBSTRUCTION.
9. IF HEIGHT > 60", AN OSHA APPROVED LADDER OR PLATFORM IS REQUIRED.
10. IF THE HEIGHT OF VALVE HANDLE > 66", AN OSHA APPROVED LADDER IS REQUIRED.

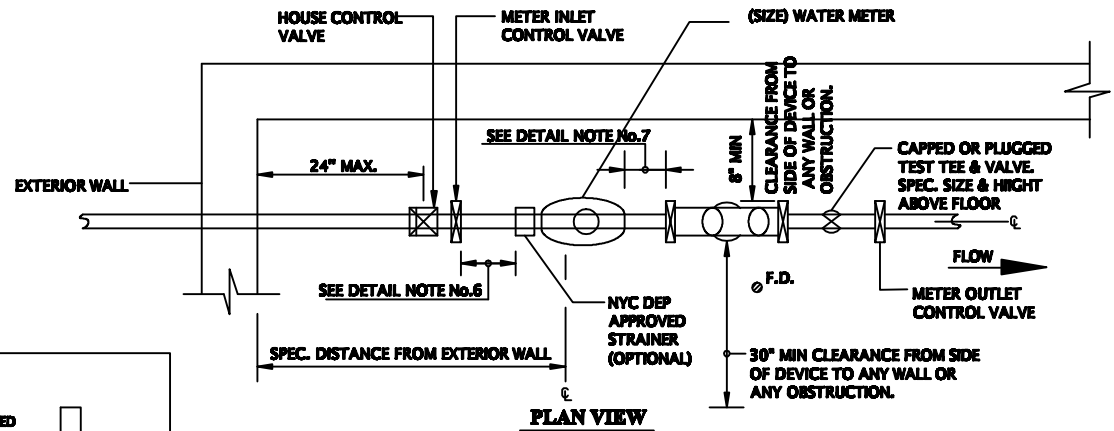
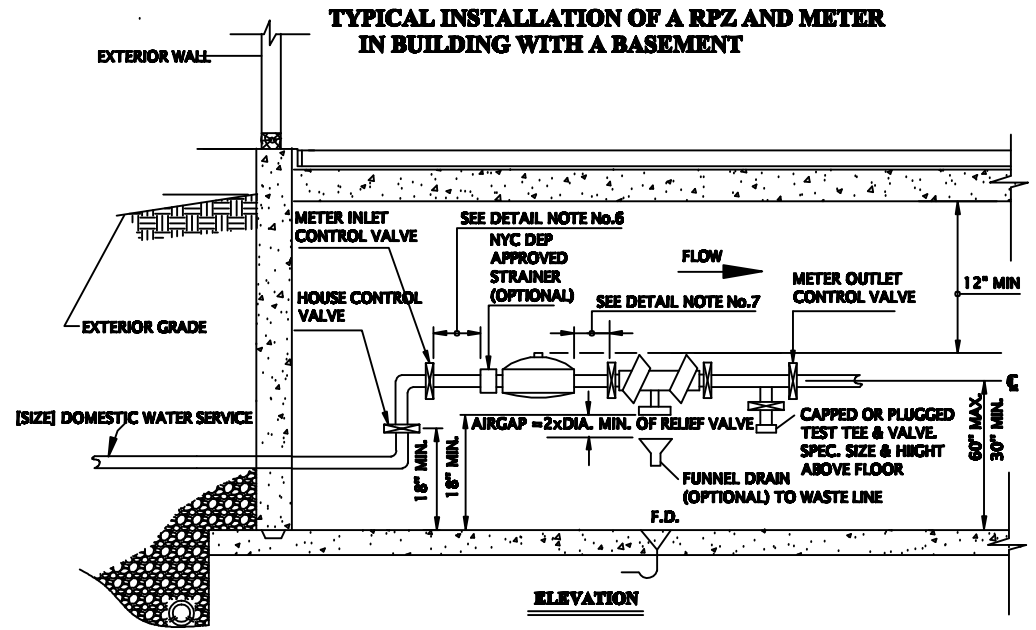
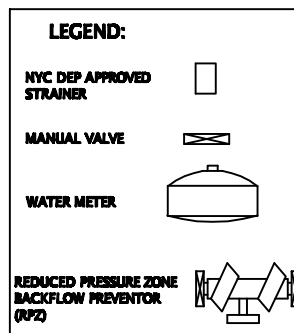

PROPOSED REDUCED PRESSURE ZONE INSTALLATION AT

COUNTY : _____ BLOCK : _____ LOT(S) : _____

ENGINEER'S OR ARCHITECT'S SIGNATURE & SEAL _____

DATE: _____



**DEPARTMENT OF ENVIRONMENTAL PROTECTION
BUREAU OF WATER AND SEWER OPERATIONS**

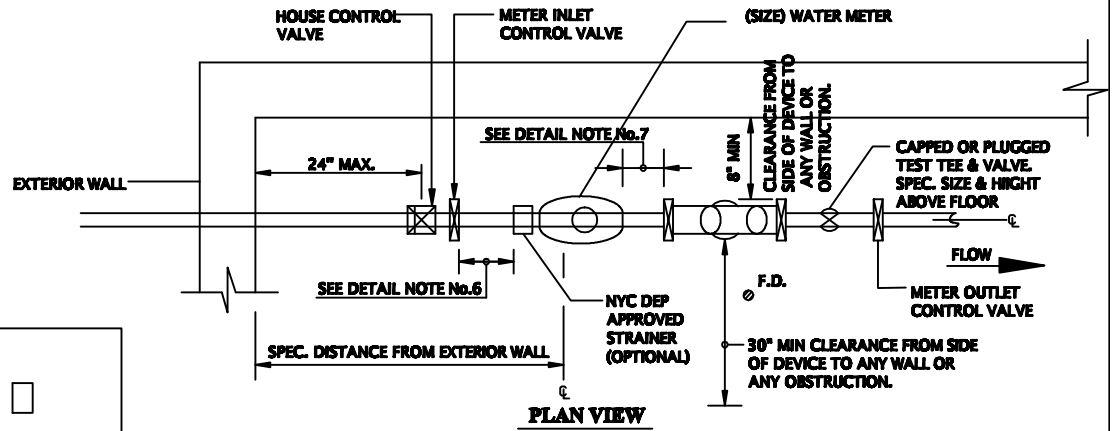
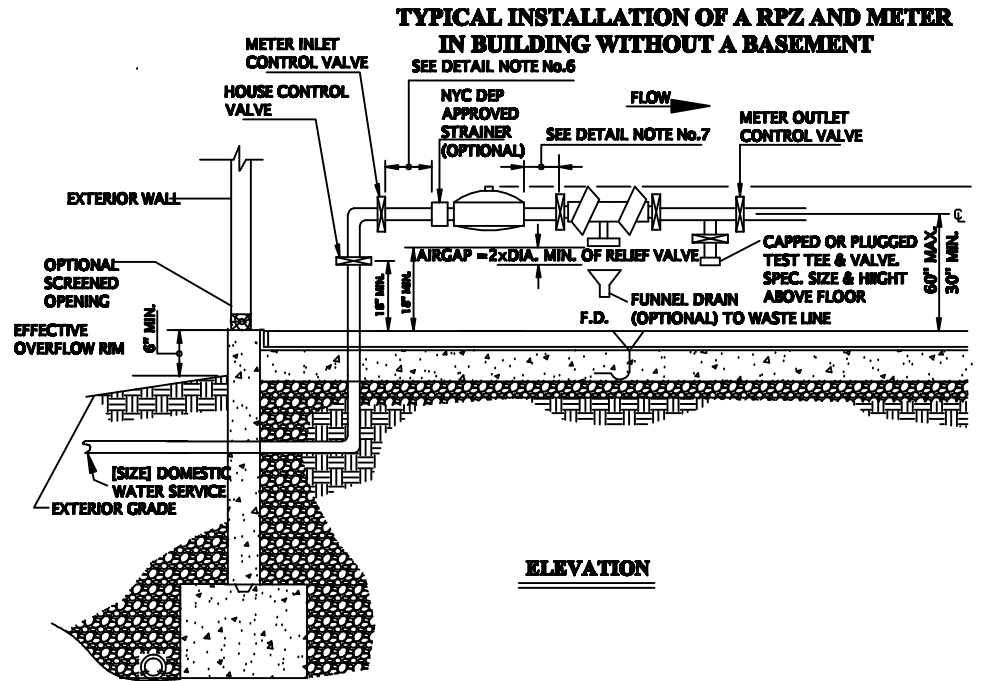
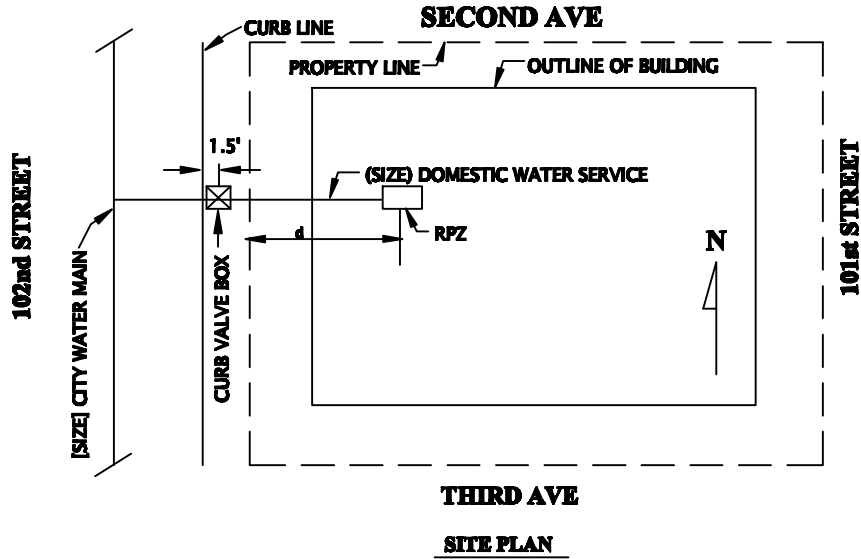

GENERAL NOTES:

1. THE INSTALLATION OF BFP SHALL MEET ALL NYC DEP CROSS-CONNECTION CONTROLL UNIT AND NYS DOH REQUIREMENTS.
2. UNLAWFUL TO REMOVE THIS DEVICE FOR ANY REASON UNLESS DEP IS NOTIFIED.
3. EACH BFP DEVICE SHALL BE TESTED ANNUALLY BY NEW YORK STATE CERTIFIED TESTER.
4. ROOM WHERE BFP DEVICE IS TO BE LOCATED HAS HEATING AND LIGHTING.
5. THE PE/RA IS RESPONSIBLE FOR CHECKING THAT THE DEVICE IS INSTALLED ACCORDING TO APPROVED PLAN AND SIGNING THE CERTIFICATION STATEMENT ON FORM GEN 215B.
6. BETWEEN POINT OF ENTRY AND BFP, PIPES MUST BE STENCILLED " FEED TO BACKFLOW PREVENTER. DO NOT TAP OR CONNECT TO THIS LINE" AT 5' INTERVALS, AND AT ALL WALL AND FLOOR PENETRATIONS.

DETAIL NOTES:

1. SPECIFY SIZE & TYPE OF METER.
2. SPECIFY SIZE & MODEL OF RPZ.
3. SEE TEXT FOR ADDITIONAL REQUIREMENTS.
4. SHOW DIRECTION OF THE FLOW IN ALL VIEWS.
5. TEST TEE MAY FACE UP, DOWN OR SIDEWAYS. TEST TEE MUST BE CAPPED OR PLUGGED.
6. FIVE (5) TIMES PIPE DIAMETER (MINIMUM).
7. THREE (3) TIMES PIPE DIAMETER (MINIMUM).
8. THIRTY (30) INCH MINIMUM CLEARANCE SPACE FROM SIDE OF DEVICE TO FARTHER WALL OR OBSTRUCTION.
9. IF HEIGHT > 60", AN OSHA APPROVED LADDER OR PLATFORM IS REQUIRED.
10. IF THE HEIGHT OF VALVE HANDLE > 66", AN OSHA APPROVED LADDER IS REQUIRED.

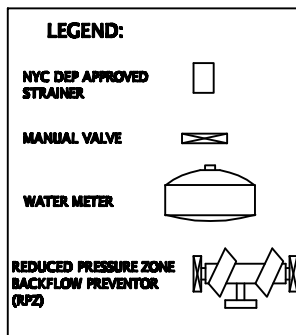

PROPOSED REDUCED PRESSURE ZONE INSTALLATION AT

COUNTY : _____ **BLOCK :** _____ **LOT(S) :** _____

ENGINEER'S OR ARCHITECT'S SIGNATURE & SEAL

DATE: _____



**DEPARTMENT OF ENVIRONMENTAL PROTECTION
BUREAU OF WATER AND SEWER OPERATIONS**

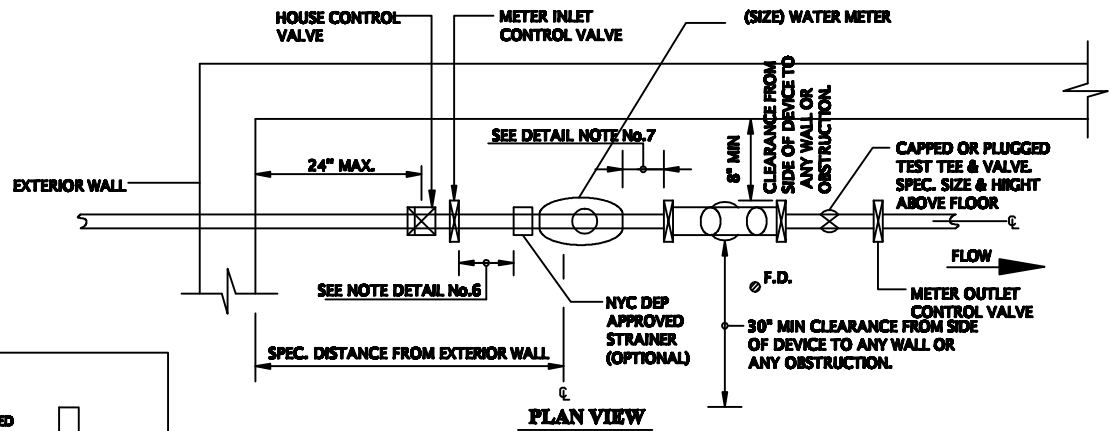
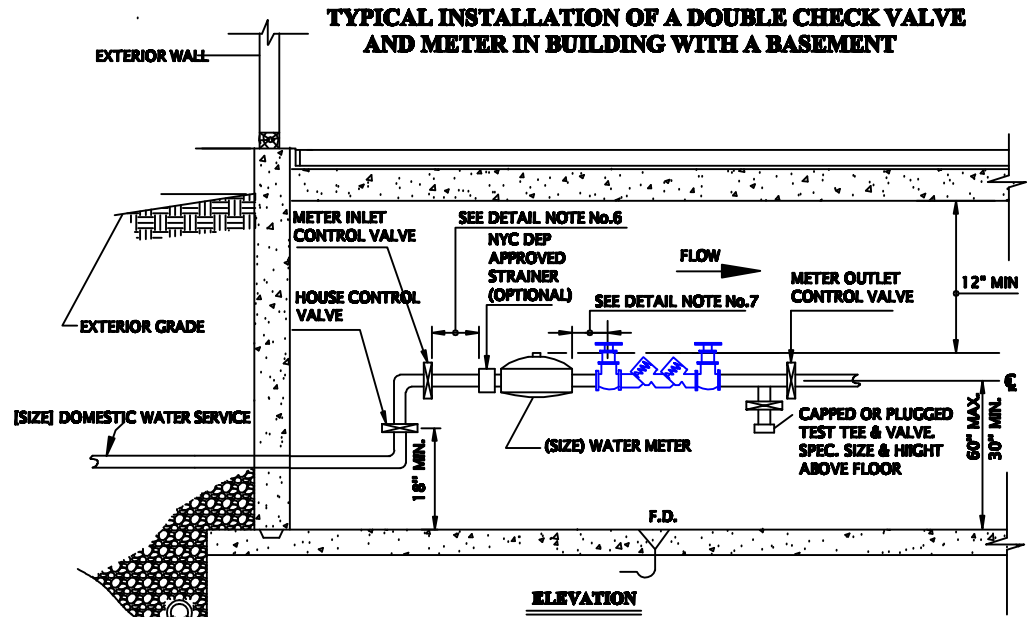
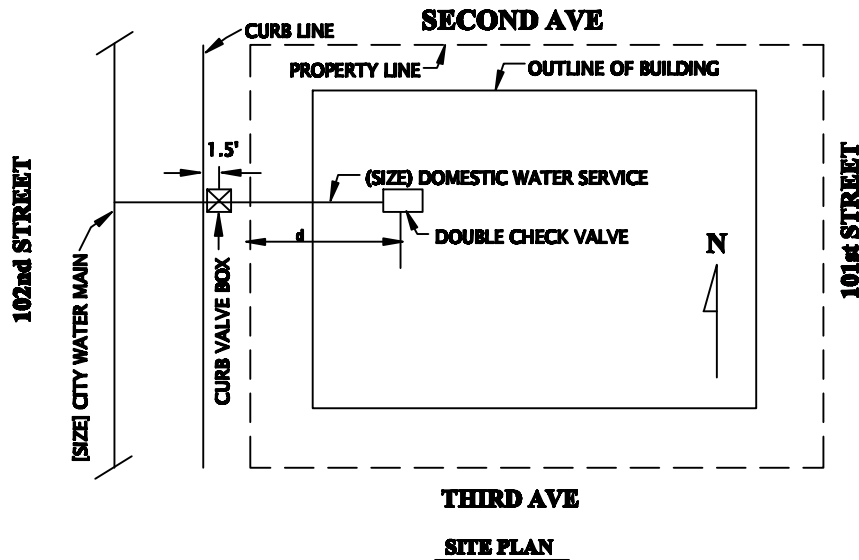

GENERAL NOTES:

1. THE INSTALLATION OF BFP SHALL MEET ALL NYC DEP CROSS-CONNECTION CONTROLL UNIT AND NYS DOH REQUIREMENTS.
2. UNLAWFUL TO REMOVE THIS DEVICE FOR ANY REASON UNLESS DEP IS NOTIFIED.
3. EACH BFP DEVICE SHALL BE TESTED ANNUALLY BY NEW YORK STATE CERTIFIED TESTER.
4. ROOM WHERE BFP DEVICE IS TO BE LOCATED HAS HEATING AND LIGHTING.
5. THE PE/RA IS RESPONSIBLE FOR CHECKING THAT THE DEVICE IS INSTALLED ACCORDING TO APPROVED PLAN AND SIGNING THE CERTIFICATION STATEMENT ON FORM GEN 215B.
6. BETWEEN POINT OF ENTRY AND BFP, PIPES MUST BE STENCILLED "FEED TO BACKFLOW PREVENTER. DO NOT TAP OR CONNECT TO THIS LINE" AT 5' INTERVALS, AND AT ALL WALL AND FLOOR PENETRATIONS.

DETAIL NOTES:

1. SPECIFY SIZE & TYPE OF METER.
2. SPECIFY SIZE & MODEL OF DOUBLE CHECK VALVE.
3. SEE TEXT FOR ADDITIONAL REQUIREMENTS.
4. SHOW DIRECTION OF THE FLOW IN ALL VIEWS.
5. TEST TEE MAY FACE UP, DOWN OR SIDWAYS. TEST TEE MUST BE CAPPED OR PLUGGED.
6. FIVE (5) TIMES PIPE DIAMETER (MINIMUM).
7. THREE (3) TIMES PIPE DIAMETER (MINIMUM).
8. THIRTY (30) INCH MINIMUM CLEARANCE SPACE FROM SIDE OF DEVICE TO FARTHER WALL OR OBSTRUCTION.
9. IF HIGHT>60", AN OSHA APPROVED LADDER OR PLATFORM IS REQUIRED.
10. IF THE HIGHT OF VALVE HANDLE>66", AN OSHA APPROVED LADDER IS REQUIRED.

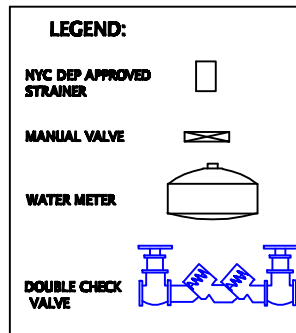

PROPOSED DOUBLE CHECK VALVE INSTALLATION AT

COUNTY : _____ BLOCK : _____ LOT(S) : _____

ENGINEER'S OR ARCHITECT'S SIGNATURE & SEAL _____

DATE: _____



**DEPARTMENT OF ENVIRONMENTAL PROTECTION
BUREAU OF WATER AND SEWER OPERATIONS**

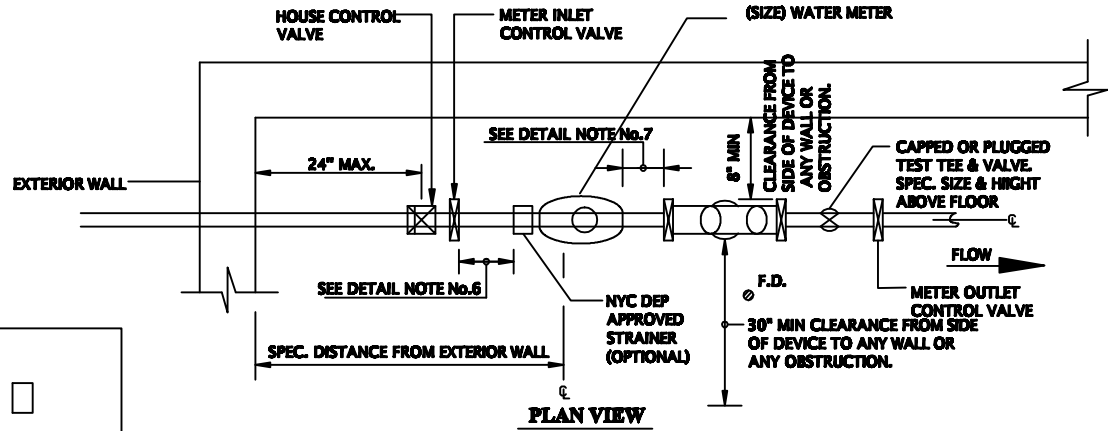
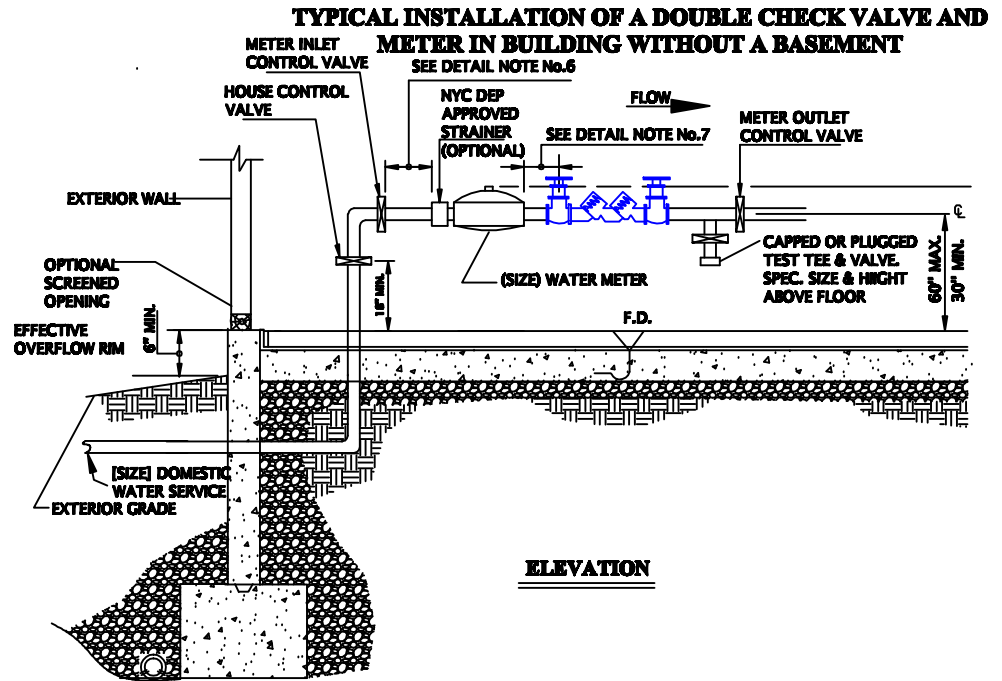
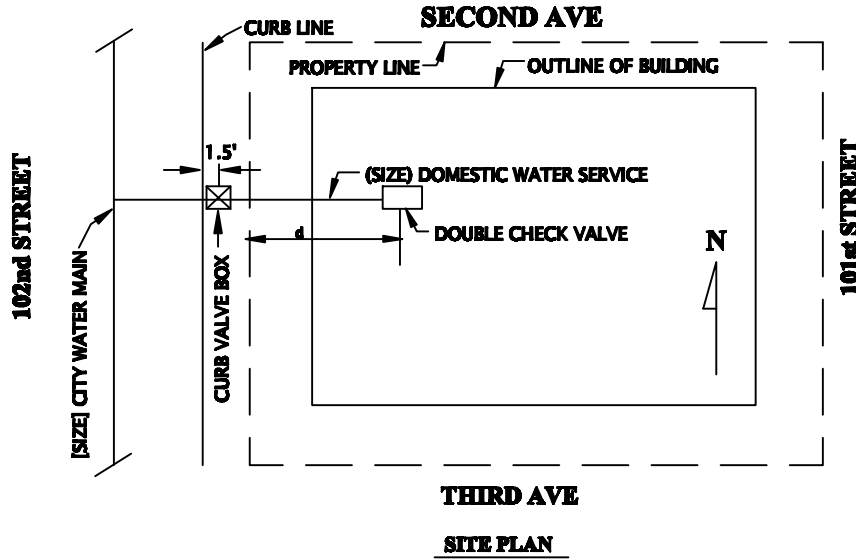

GENERAL NOTES:

1. THE INSTALLATION OF BFP SHALL MEET ALL NYC DEP CROSS-CONNECTION CONTROLL UNIT AND NYS DOH REQUIREMENTS.
2. UNLAWFUL TO REMOVE THIS DEVICE FOR ANY REASON UNLESS DEP IS NOTIFIED.
3. EACH BFP DEVICE SHALL BE TESTED ANNUALLY BY NEW YORK STATE CERTIFIED TESTER.
4. ROOM WHERE BFP DEVICE IS TO BE LOCATED HAS HEATING AND LIGHTING.
5. THE PE/RA IS RESPONSIBLE FOR CHECKING THAT THE DEVICE IS INSTALLED ACCORDING TO APPROVED PLAN AND SIGNING THE CERTIFICATION STATEMENT ON FORM GEN 215B.
6. BETWEEN POINT OF ENTRY AND BFP, PIPES MUST BE STENCILLED " FEED TO BACKFLOW PREVENTER. DO NOT TAP OR TAP OR CONNECT TO THIS LINE" AT 5' INTERVALS, AND AT ALL WALL AND FLOOR PENETRATIONS.

DETAIL NOTES:

1. SPECIFY SIZE & TYPE OF METER.
2. SPECIFY SIZE & MODEL OF DOUBLE CHECK VALVE.
3. SEE TEXT FOR ADDITIONAL REQUIREMENTS.
4. SHOW DIRECTION OF THE FLOW IN ALL VIEWS.
5. TEST TEE MAY FACE UP, DOWN OR SIDEWAYS. TEST TEE MUST BE CAPPED OR PLUGGED.
6. FIVE (5) TIMES PIPE DIAMETER (MINIMUM).
7. THREE (3) TIMES PIPE DIAMETER (MINIMUM).
8. THIRTY (30) INCH MINIMUM CLEARANCE SPACE FROM SIDE OF DEVICE TO FARTHER WALL OR OBSTRUCTION.
9. IF HEIGHT > 60", AN OSHA APPROVED LADDER OR PLATFORM IS REQUIRED.
10. IF THE HEIGHT OF VALVE HANDLE > 66", AN OSHA APPROVED LADDER IS REQUIRED.

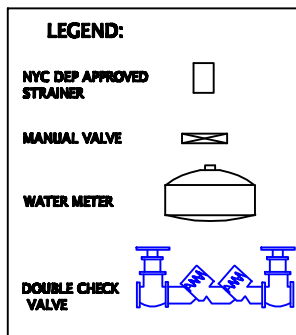

PROPOSED DOUBLE CHECK VALVE INSTALLATION AT

COUNTY : BLOCK : LOT(S) :

ENGINEER'S OR ARCHITECT'S SIGNATURE & SEAL

DATE:

**DEPARTMENT OF ENVIRONMENTAL PROTECTION
BUREAU OF WATER AND SEWER OPERATIONS**

CROSS CONNECTION CONTROL RISK ASSESSMENT - REVISED MAY 2010

General Domestic

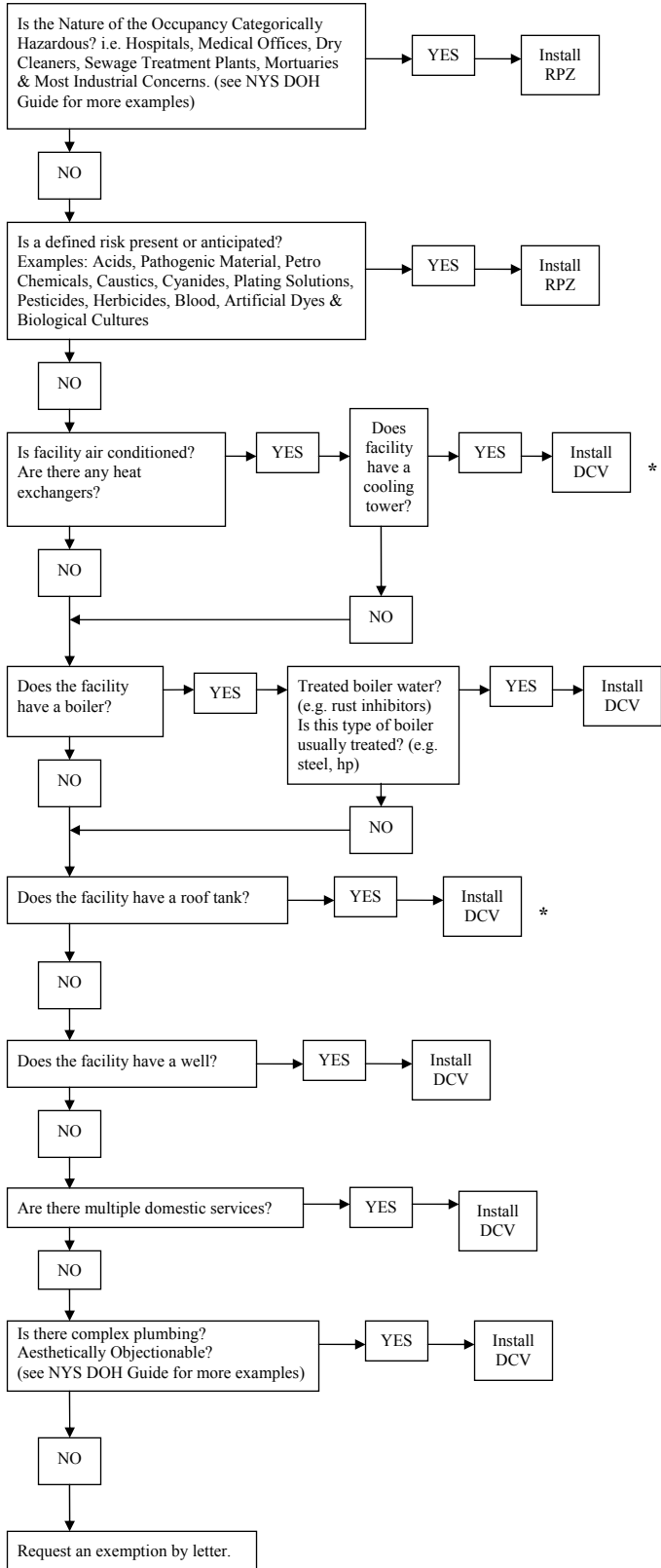

General Fire Sprinkler/Standpipe

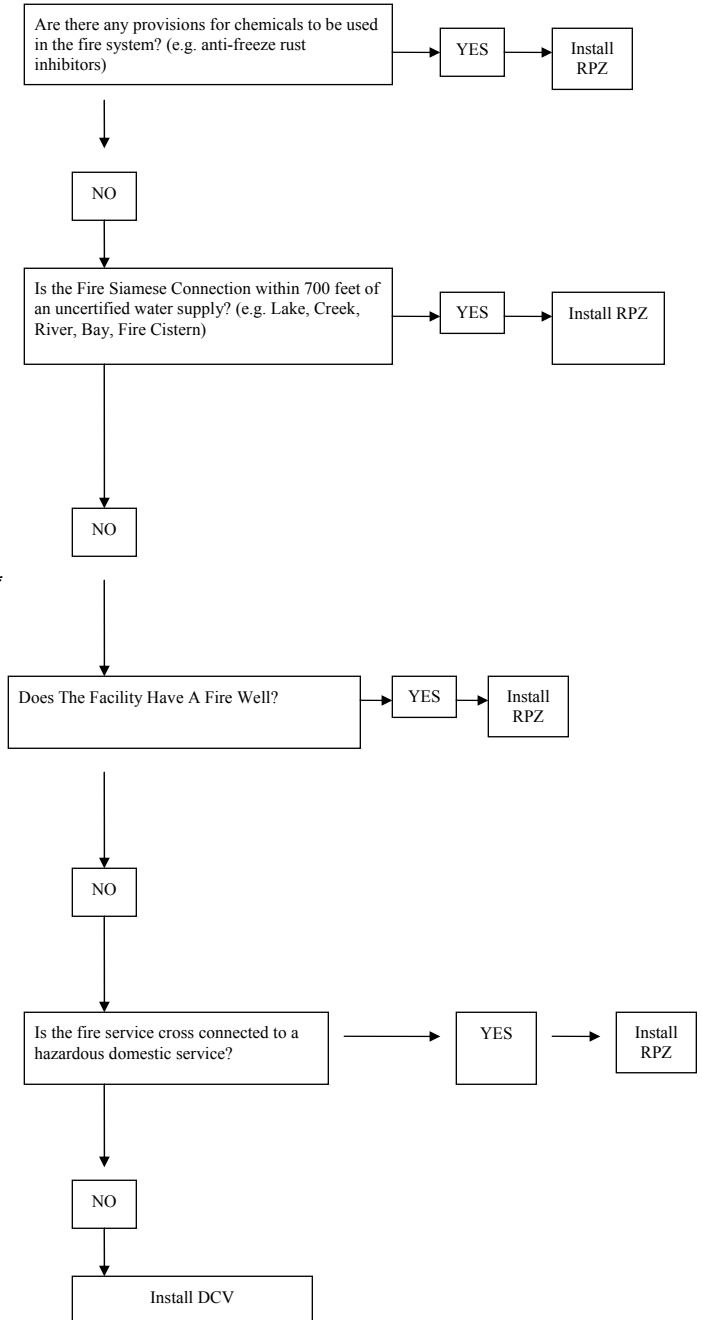

* For facilities with roof tanks, cooling towers or treated boilers, DCV's may be installed provided that internal protective devices are installed in accordance with the Department of Building requirements.

DCV = approved Double Check Valve Assembly
RPZ = approved Reduced Pressure Zone Device

**INSTRUCTIONS FOR GETTING A BACKFLOW PREVENTER EXEMPTION
(FOR DOMESTIC SERVICE ONLY)**

1. Use Risk Assessment to determine that the facility does not require a Backflow Prevention Device.
2. **Type** a letter on your letterhead following the format of the sample letters. Do not omit any of the points. We require **TWO** copies.
3. Describe the building and it's occupancy in detail (*Example – The first floor will contain a clothing store and a stationary store. The second and third floors will contain residential units only*).
4. **For a facility with a Domestic Service only:**
 - a) Use the sample letter that corresponds to your facility (residential, mixed use or non-residential) as a guide.
 - b) Provide information about the type of domestic service.
5. If plans have been submitted to the Building Department or if plans have been drawn up by a P.E./R.A. the letter should be signed and sealed by the same P.E./R.A.
6. Submit One copy to:
NYC-DEP
Division of Permitting & Inspections
3rd Floor Low-Rise
59-17 Junction Blvd.
Flushing, NY 11373
7. If an exemption is denied, the owner, his engineer or architect must submit two (2) sets of plans to install the backflow prevention device.

Form for Backflow Prevention Device Exemption for a Facility with One Domestic Service Only

If the facility meets ALL of the conditions that are stated in the sample letter below, TYPE a letter on your letterhead giving us all of the information shown on the sample letter. Do not omit any of the points. Submit to the Cross-Connection Control Unit for approval. NOTE: Where we show (bracketed italicized items), you must provide the appropriate information for your facility.

PE / RA / LMP LETTERHEAD

(Date)

DEP Bureau of Water & Sewer Operation
 Cross-Connection Control Unit
 59-17 Junction Blvd. 3rd Floor Low-rise
 Flushing, NY 11373

Re: Backflow Prevention Device exemption for a
 Facility with a domestic service only
(Address)

Block: Lot: County:

Gentlepeople:

Based on the information provided below we respectfully request a review of the *(existing building with existing service, existing building with new service, building being renovated, future building)* with regards to backflow prevention requirements.

The referenced location *(is/will be) (residential/commercial/educational/industrial/etc.)*, and *(is/will be)* supplied by only one service for domestic purposes, which is *(size)* inch and no fire services. *(Describe building and occupancy in detail. Include number of floors and, if residential, the number of units.)*

The facility *(does/will)* **NOT** contain any of the following:

- | | |
|---|--|
| BAKERY | AUTO BODY / REPAIR SHOPS |
| BIDETS | BEAUTY SALONS OR BARBER SHOPS |
| CAR WASH | BUTCHERS (INCLUDES FISH MARKETS & LIVE STOCK) |
| CHEMICALS USED IN PROCESSING e.g.
DYE PLANTS, PHOTO LABORATORIES | CHEMICALLY TREATED BOILERS |
| COMMERCIAL LAUNDRY FACILITIES WITH 2 OR MORE
COIN OPERATED MACHINES | DRY-CLEANING ESTABLISHMENTS |
| DELICATESSEN /PREMISES WHERE FOOD IS BEING
PREPARED | COMMERCIAL KITCHENS / RESTAURANTS |
| DENTAL OFFICES /LABORATORIES | LARGE BOILERS (MORE THAN 350000 BTU) |
| DISTILLED BREWERIES | BOOSTER PUMPS |
| FUNERAL PARLORS | HOTELS AND/OR MOTELS |
| GREENHOUSES | GAS STATIONS AND/OR MINI MARTS WITH SODA MACHINES OR
COFFEE LINES |
| IN-GROUND IRRIGATION SPRINKLER
WELLS (GROUNDWATER) | HEAT EXCHANGERS WITH WATER (SINGLE WALL) |
| MULTIPLE WATER SERVICES | PHARMACY |
| SEWAGE TREATMENT OR HANDLING | PRESSURE TANKS |
| VETERINARY OFFICES / LABORATORIES | PRIVATE WELLS |
| WAREHOUSES (WITH TOXIC CHEMICALS STORAGE) | SWIMMING POOLS / COMMERCIAL SWIMMING POOLS |
| | METAL MANUFACTURING, CLEANING, PROCESSING OR
FABRICATING PLANTS |
| | WATER COOLED EQUIPMENT OR CHILLERS |
| | WATER STORAGE TANKS |
| WATER REUSE / RECYCLING | |
| MEDICAL OFFICES / LABORATORIES
(INCLUDES PSYCHOLOGY & PSYCHIATRIC OFFICES THAT
ADMINISTER MEDICATION) | |

Based on this information and a detailed and thorough inspection of the *(existing building/plans)*, we believe this building is non-hazardous and does not require a backflow prevention device. We are fully aware that if any of the above conditions change, the installation of an appropriate backflow prevention device may be mandatory.

 Property Owner's Name
 Property Owner's Mailing Address
 Owner's Phone Number
 Owner's Signature

 PE/RA or Plumber's Name:
 License Number: *(if not on letterhead)*
 Phone Number: *(if not on letterhead)*
 PE/RA or LMP Seal & Signature

If you wish, you may adapt this specification to your labeling requirements. There are also several types of proprietary labels available, many of which are appropriate for identifying feed lines to backflow prevention devices.

SPECIFICATION FOR PIPE IDENTIFICATION

Pipe must be continuously stenciled or labeled:

FEED TO BACKFLOW PREVENTER, DO NOT TAP OR CONNECT TO THIS LINE.

From:

To:

The lettering shall be two (2) inches high, in a bold, condensed, sans serif, gothic font, using capitals only.

Identification shall be stenciled onto a prepared background using an acceptable permanent paint. Labels must be rot and water proof. Self adhesive labels must have a permanent water proof adhesive. Non-adhesive labels shall be attached using a permanent proof adhesive. Sample shall be submitted to the engineer for approval.

Color:

For domestic lines, black letters on a white background.

For fire lines, white letters on a red background.

NEW YORK STATE DEPARTMENT OF HEALTH
BUREAU OF PUBLIC WATER SUPPLY PROTECTION
GUIDELINES FOR DESIGNING
BACKFLOW PREVENTION ASSEMBLY INSTALLATIONS
SUPPLEMENT TO THE 1981 CROSS CONNECTION CONTROL MANUAL
JANUARY 1992

Purpose

The purpose of these guidelines is to augment and/or clarify those guidelines outlined in the January 1981 Cross Connection Control manual. These guidelines reflect accepted design considerations based on experience in implementing cross connection control programs and policies set forth by the American Water Works Association, Environmental Protection Agency, USC Foundation for Cross Connection Control and Hydraulic Research and state and local health departments. Pending revisions to the manual, these guidelines should clearly outline what an acceptable design and installation constitutes. They are to be reasonably interpreted and will be updated as new design solutions and technologies are offered.

General Installation Details

I. Clearances

All double check valve (DCV) and reduced pressure zone (RPZ) backflow prevention assemblies are designed for in-line service and must be installed to prevent freezing, flooding and mechanical damage with adequate space to facilitate maintenance and testing. Ideally, the installation should not require platforms, ladders or lifts for access. Adequate clearances from floors, ceilings and walls must be provided to access the test cocks and to allow the repair and/or removal of the relief valve and check valves, as follows:

- All assemblies shall be installed with a centerline height from 30 inches to 60 inches above the floor. Any installation at a greater height shall be provided with a fixed platform, a portable scaffold or a lift meeting OSHA standards.
- All RPZ devices must have an 18 inch minimum clearance between the bottom of the relief valve and the floor to prevent submersion and provide access for servicing the relief valve.
- A minimum of 12 inches of clear space shall be maintained above the assembly to allow for servicing check valves and for operation of shut-off valves.
- A minimum of 30 inches of clear space shall be maintained between the front side of the device and the nearest wall or obstruction.
- At least 8 inches clearance should be maintained from the back side of the device to the nearest wall or obstruction. This clearance may need to be increased for models that have mounted test cocks or relief valves that would be facing the back wall.

II. Miscellaneous Considerations

- All assemblies shall be adequately supported and/or restrained to prevent lateral movement. Pipe hangers, braces, saddles, stanchions, piers, etc., should be used to support the device and should be placed in a manner that will not obstruct the function of or access to the relief valve.

- Strainers are recommended prior to each backflow prevention assembly on non-fire fighting water lines. No strainer is to be used in a fire line without the approval of the insurance underwriters or the authority having jurisdiction.
- The assembly should be sized hydraulically, taking into account both the volume requirements of the service and the head loss of the assembly. The head loss of the assembly is not necessarily directly proportional to flow. (Refer to the manufacturer's head loss curves).
- Before selection and installation, refer to manufacturer's literature for temperature ranges. All assemblies must be protected from freezing temperatures and if installed where temperatures will reach 110 degrees F or above, a hot water type assembly be used. Consult manufacturer's specification for recommendations.
- Thermal water expansion and/or water hammer downstream of the assembly can cause pressure. To avoid possible damage to the system and assembly, use water hammer arresters, surge protectors or expansion tanks as appropriate.
- All assemblies should be specified and installed with the manufacturer supplied resilient seated shut-off valves integral to the assembly.
- Water lines should be thoroughly flushed before installing the assembly. Most test failures on new installations are the result of debris fouling one of the check valves or the relief valve.
- All assemblies must be installed horizontally unless they are specifically approved for vertical installation. (Ref. Technical Reference PWS-14).
- Parallel installations should be considered at those facilities where water service cannot be interrupted. Manifold installations may also be used on any water line larger than 10 inches.
- Assemblies shall not be installed in areas containing corrosive, toxic or poisonous fumes or gases which could render the assembly inoperable or pose a safety hazard to personnel.
- Because of the inherent design of a reduced pressure backflow assembly, fluctuating supply pressure on an extremely low flow or static flow conditions may cause nuisance dripping and potential fouling of the assembly. While not effective in all cases, the installation of a soft seated check valve immediately ahead of the RPZ will often hold the pressure constant to the assembly in times of fluctuating supply pressure.
- Where the distance between the water meter and the device is greater than 10 feet, all exposed piping should be stenciled "Feed Line To Backflow Prevention Device- DO NOT TAP" at 5 foot intervals.

Drainage

Drainage for backflow prevention assemblies shall be provided for all installations of DCV or RPZ to accommodate discharge during testing or draining of the unit and for RPZ relief valve discharges, as follows:

- For RPZ devices, drainage capacity shall be sized to accommodate both intermittent discharges and a catastrophic failure of the relief valve. Refers to manufacturer's flow curves to determine maximum discharge rate based on supply pressure or on-site pressure; whichever is greater.

- Discharge from relief valves must be readily detectable to maintenance personnel either visually or by means water level alarms, flow indicator light, etc.
- All drainage from RPZ's must be by gravity drains. Sump pumps are not allowed unless they are sized to accommodate the maximum discharge rate and connected to emergency power supplies.
- An air gap must be maintained between the RPZ relief valve opening and any discharge piping. The air gap must be at least twice the dimension of the effective opening of the valve; but in no case less than 1 inch.
- Manufacturer's air gap fittings may be utilized provided that they maintain a proper air gap and do not enclose or cover the relief valve. These fittings are only sized to handle intermittent and low flow discharge. Additional drainage capacity may be required to accommodate a catastrophic relief valve failure.
- Discharge piping from relief valves using manufacturer's air gap fittings shall be terminated a minimum of 2 inch above any floor drain or other receiving receptacle.
- Discharge piping connected to a storm sewer shall be equipped with backwater check valve.
- Discharge piping connected to a sanitary sewer shall be trapped and equipped with a backwater check valve.
- Discharge piping from pits or other structures must be terminated above grade in an area not subject to flooding (generally one foot above the 100 year flood elevation). The terminal end of the discharge piping must have a rodent screen and may need to be supported by a headwall. Flap valves should also be considered to prevent entry of cold air.
- All exterior drains shall be kept free of snow during winter.

Pit Installations

Primarily due to considerations for access, safety and gravity drainage, it is preferred that backflow prevention devices not be installed in pits. Where pit installations are proposed, however, they shall be designed:

- To be watertight with watertight manholes or access doors extending a minimum of 6 inches above grade and located to allow natural light into the pit during testing/maintenance.
- With stairways, ladders or step irons.
- For crane access for installing and removing large assemblies.
- With adequate horizontal and vertical clearances to allow access to the device.
- With a full flow screened gravity drain.
- With sump pumps or gravity daylight drains for all DCVA installations.
- With floor pitched to the drain.

- With adequate ground cover to prevent freezing.
- With surface grading to divert runoff away from the entrance way.
- Semi-buried pits or berm installations may be necessary to satisfy gravity drainage requirements.

Above Grade Installations- Protective Enclosures

An above grade installation is generally necessary to provide gravity drainage from RPZ devices. The additional benefits of improved access and enhanced safety are also realized with an above grade installation. Two companies, “Hot Box” and “Hydrocowl”, have designed prefabricated insulated enclosures that provide heat, gravity drainage and removable access panels for servicing and testing. As an alternate, wood frame, fiberglass, steel, masonry or precast concrete structures may be utilized. All enclosures shall be designed:

- With a floor elevation that is at least 6 inches above finished grade.
- To provide adequate clearances around the device to access the test cocks, shutoff valves, check valves and relief valve.
- With electric heaters or heat trace wire for any water service used year round.
- With provisions for natural or artificial light.
- With full flow gravity drains according to the drainage requirements.
- With security measures such as locking doors and panels, flow alarms or flow indicator lights, power indicator lights, etc.

Installation within a Building

Where containment at the property line cannot be achieved or is waived based on extenuating circumstances, installation within a building is often desirable as the unit can be installed in a mechanical room or other area that has heat and light. Access and drainage considerations must also be satisfied and the devices should be located to avoid electrical panels, areas of excessive heat, etc.

1. Above grade installations shall be provided with adequate clearances and discharge can be directed to floor drains or through a sidewall above grade via screened louvers, scuppers, pipe sleeves with flap valves, etc., in accordance with the drainage requirements.
2. Below grade or basement installations are acceptable for DCVA’s. RPZ’s are only allowed below grade where one or more of the following conditions can be met:
 - Where an adequate gravity drainage system is provided to accommodate a relief valve failure.
 - Where water level alarms are installed to detect flow from the device and alert maintenance or security personnel.
 - Where sump pumps are sized to accommodate a relief valve failure and are connected to emergency power.

- Where the floor area and volume below the device could accommodate discharge from a relief valve failure. For 2 inch and smaller units, 2,000 cubic feet is generally acceptable. For larger units, the time to submerge the device based on the maximum discharge rate and floor area/volume should be no less than 8 hours.

In any of the above cases, the property owner must be made aware of the potential for water damage in the event of a discharge.

Submission and Approval of Plans

In accordance with Section 10 of the Cross Connection Control manual, the submission of plans and specifications for the installation of backflow prevention assemblies must include the following:

1. A site plan (to scale or with dimensions) of the facility containing a general location map, name and address of facility, property lines, buildings, the size and location of public water mains(s) and all fire and domestic water services, meter pits, yard piping and hydrants, pumper connection(s), interconnections, and the location of the proposed backflow prevention device(s):
2. A plumbing floor plan (plan view) or partial floor plan indicating water services, name and address of facility, water meter layout, proposed backflow prevention device(s), booster pump system, floor drains(s) and all nearby objects (examples: electrical panels, boilers, chillers, storage tanks, fire pumps, fire sprinkler risers, etc.). The plan must be drawn to scale or with dimensions indicated from walls and all nearby objects:
3. A vertical cross section(s) of the proposed installation with elevations from floor, ceiling, outside grade and all nearby objects.
4. All drawings must include the name and address of the facility, be stamped and signed by the designer and have a clear space for approval stamps.

Engineer's Report

An engineering report must be included with the plan submittal. The report must describe the project in detail. Items that should be included or described in the report include:

- General use of water within the facility.
- Size and description of all fire and domestic water services.
- Number of floors within the facility.
- Actual or estimated maximum flow demand.
- Pressures – existing and after the installation of the backflow prevention device.
- Description of the fire fighting system – indicate the A.W.W.A. Manual M-14 class of sprinkler service.

- Description of the proposed installation of the backflow prevention device – indicate the location of backflow prevention device, drainage, lighting, heating, access to unit, square footage of the floor level where the backflow prevention is to be located.

Description of the existing or proposed booster pump system, answering the following questions:

1. After the installation of the proposed backflow prevention device(s), will the Net Positive Suction Head (NPSH) required for the proper operation of the booster pump system be adequate?
2. After the installation of the backflow prevention device(s) in the suction line to the booster pump system, will the booster pump system operate properly at peak demand to deliver adequate pressure to the highest elevation and /or most remote fixture unit or any other operation requiring a certain pressure?

Note: The New York State Uniform Fire Prevention and Building Code Part 902.4c requires the minimum pressure at water outlet at all times to be as follows:

Fixture – non flush valve – 8 psi

Fixture – flush valve – 15 psi

3. Does the booster pump system have a pressure cutoff switch in the suction line? What is the pressure setting of the switch? An existing or proposed cutoff switch must be set at the following setting:

For a cutoff switch where the backflow prevention device is located upstream of the booster pump(s) - set at 10 psi

For a cutoff switch where the backflow prevention device is located downstream of the booster pump(s) - set at 20 psi

4. The need for dual backflow prevention device. Does the facility need a continuous water supply?
5. The elevation and location of the 100 year flood plain in relation to the facility. A reduced pressure zone (RPZ) backflow prevention device must generally be installed 1 foot above the 100 year flood plain elevation.
6. An inventory of any existing containment devices to include the make, model, size and serial number of the device. Current annual test reports must also be submitted. The degree of hazard for these services must be determined to insure that the device provides the correct protection.

Certified Testing and Completed Works Approval

After an approval of plans has been issued and the assembly has been installed, it must be tested by a certified tester. The designer (or water supplier) is then responsible to certify that the installation was done in accordance with approved plans; or describe any changes or submit “As Built” plans as appropriate.

The initial test result and certification are then submitted to the water supplier and approving agent for issuance of a Completed Works Approval. DOH- Form 1013 has been designed for both the certified test results and the designer’s certification of the installation.

After issuance of the Completed Works Approval, the assembly must be tested at least annually by a certified tester with the results reported to the water supplier.

§20-04 BACKFLOW PREVENTION DEVICES, WATER HAMMER ARRESTERS, PUMPS AND SEPARATION VALVES

(a) Backflow Prevention Devices

Reduced Pressure Zone devices (RPZ’s) and Double Check Valve Assemblies are backflow prevention devices. Backflow prevention devices shall be installed to prevent possible backflow / backsiphonage from a commercial property or dwelling unit into a City water main, private water main, or internal water main. A property owner shall install an approved backflow prevention device in every water service pipe that has a potential cross connection hazard, as determined by the Commissioner.

(b) Backflow Prevention Device Requirements

Backflow prevention devices shall be installed to address potential hazard, as follows:

DEP CONTAINMENT REQUIREMENT

DEGREE OF HAZARD	PROTECTION REQUIRED
Hazardous Facilities	Air Gap or Reduces Pressure Zone Device
Aesthetically Objectionable	Double Check Valve Assembly
Non-Hazardous Facilities with Hazardous Fixtures (such as treated boilers, cooling towers, etc.)	Double Check Valve Assembly (Provided that internal protective devices are installed for the hazardous fixtures in accordance with Department of Building requirements).
Non- Hazardous Facilities	None

Subject to review by the Department, the degree of hazard shall be determined by the property owner’s Licensed Professional Engineer, Registered Architect or Licensed Master Plumber in accordance with guidelines established by the New York State Department of Health.

(c) Cross Connection Control Reviews

A cross Connection Control Review shall be required prior to approval of a permit application for installation of a corporation stop (tap) or wet connection that will be used to supply water to a property that poses a backflow hazard. A Cross Connection Control Review shall also be required prior to installation of a two (2) inch corporation stop (tap) or wet connection.

(d) Installation of Backflow Prevention Devices

Where the Commissioner determines that a facility poses a potential hazard to the City Water Supply, he or she shall direct the building owner or customer to install an approved backflow prevention device in the service pipe.

A Licensed Master Plumber shall submit an application to the Department of Buildings for a permit or an approval to install a RPZ or a Double Check Valve Assembly. RPZ's and Double Check Valve Assemblies shall be installed in accordance with plans approved by the Department. A Licensed Professional Engineer or Registered Architect shall inspect and certify that the complete installation conforms to plans approved by the Department.

A building owner or customer who fails to install a backflow prevention device as directed by the Commissioner shall be subject to the issuance of notices of violation, cease and desist orders, other civil and criminal actions and proceedings, and such fines, penalties and other enforcement measures as may be imposed pursuant to section 24-346 of the Administrative Code, including but not limited to the termination of the water supply to the building or to any portion thereof or a facility therein which the Environmental Control Board or the Commissioner may deem necessary to prevent or alleviate any hazard to the City Water Supply.

The customers shall pay any fees which the New York City Water Board may establish in connection with the termination or restoration of Water service to the customer.

(e) Backflow Prevention Device Testing Requirements

Each RPZ or Double Check Valve must be tested upon installation and at least once annually, thereafter, by a backflow prevention device tester who is certified by the New York State Department of Health. A test report certifying that the backflow prevention device is operating properly must be submitted to the Department.

Defects in any device tested shall be repaired within thirty (30) days, and the repair shall be followed by a retest. Retest results shall be submitted to the Department within thirty (30) days of completion of the repair.

Failure of a building owner or customer to provide an annual test report certifying that an existing backflow prevention device installed pursuant to this section or otherwise is properly operating shall be a violation of these rules.

(f) Suspension of Service Due to Backflow

Where a backflow is detected from premises into a City water main or a private water main, the water supply to the premises may be terminated by the Department.

Prior to restoration of water service, a Licensed Master Plumber must certify to the Department that the backflow has been eliminated, and an approved backflow prevention device has been installed.

The customers shall pay any fees that the New York City Water Board may establish in connection with the termination or restoration of water service to the customer.