

# **BCC SUBMISSION GUIDE**

## **DOB NOW & BIS APPLICATIONS**

Update: December 2024

# Table of Contents

- 1. Building Code Compliance (BCC).....5
- 2. BCC Website .....7
  - 2.1. Calendly Appointment.....8
  - 2.2. BCC Guides, Procedures & Resources .....9
- 3. Submission Requirements.....12
  - 3.1. BCC Plan Exam Transmittal Form.....13
  - 3.2. SCA Owner Info.....14
  - 3.3. Property Ownership Certification.....15
  - 3.4. Fee Exempt Document.....16
  - 3.5. Public Design Commission (PDC)/ Landmarks (LPC).....17
  - 3.6. TR4/ Soil Report.....18
  - 3.7. Asbestos.....19
  - 3.8. Artwork on EQ's.....20
  - 3.9. DHCR.....21
  - 3.10. HPD-2 .....22



# Table of Contents (Cont'd)

<b>4. Submission Process.....</b>	<b>23</b>
4.1. OneDrive Folder Structure.....	26
<b>5. Plan Review.....</b>	<b>33</b>
<b>6. Resubmission.....</b>	<b>35</b>
<b>7. Appointment.....</b>	<b>40</b>
<b>8. Approval.....</b>	<b>41</b>
<b>9. Post Approval Amendment (PAA) .....</b>	<b>42</b>
<b>10. Withdrawal.....</b>	<b>44</b>
<b>11. Supersede .....</b>	<b>48</b>
<b>12. CCD1 Request.....</b>	<b>51</b>
<b>13. Zoning &amp; Egress Review Request.....</b>	<b>52</b>
<b>14. Certificate of Compliance (COC).....</b>	<b>53</b>

# Table of Contents (Cont'd)

15. Boiler Equipment (BE).....	56
16. Schedule of Occupancy.....	57
17. Place of Assembly .....	58
18. FDNY filings – FA/ FPP/ FS.....	63
19. Non-file/ permit exempt projects.....	64
20. BCC Mailbox .....	65
21. FAQs.....	66
<b>22. DOB Resources</b>	
20.1. Login to DOB NOW.....	68
20.2. Special & Progress Inspections vs. Work Types .....	69
20.3. Waiver and Deferral Document Request List .....	70
20.4. DOB NOW: Build - Filings Resources.....	71
20.5. DOB NOW Training.....	72
20.6. DOB NOW: Build Frequently Asked Questions.....	73

# 1. Building Code Compliance (BCC)

- DOB's "6th Borough" Office for school construction
- All DOB Services including: Plan Approval, Permits, Inspections, Close-out
- Processing is done in two systems

Use online filing **DOB NOW: Build** for:  
Plan Examination, Permits, and Close-out

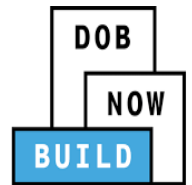

Use **BCC 2.0**: SCA Regulatory System for:

Checking application Status, Objections checklist,  
Permit checklist, Reviewing IFA Reports, Track Close-out  
Submissions, Access Edocs Drawings and Documents,  
Sends auto-emails with regulatory milestones

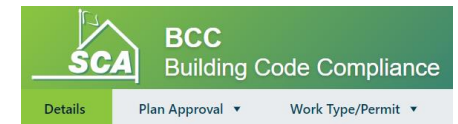

# 1. Building Code Compliance (BCC)

- **BCC 2.0 Access**
  - Fill out an ITF-1B confidentiality and non-disclosure agreement and email [planreview@nycsca.org](mailto:planreview@nycsca.org) to create a BCC System account. The same Citrix account can be used with other SCA systems for collaboration. Citrix accounts are sometimes called “CON” accounts.
- Use Microsoft **OneDrive** for collaboration
  - Email [planreview@nycsca.org](mailto:planreview@nycsca.org) to request for OneDrive folder access and link
  - If you require access to OneDrive remember to include DOB Number, Plan Examiner and list all of the people on the team who require access (name and email address is required)

# 2. BCC Website

<http://www.nycsca.org/Doing-Business/SCA-Plan-Examination>

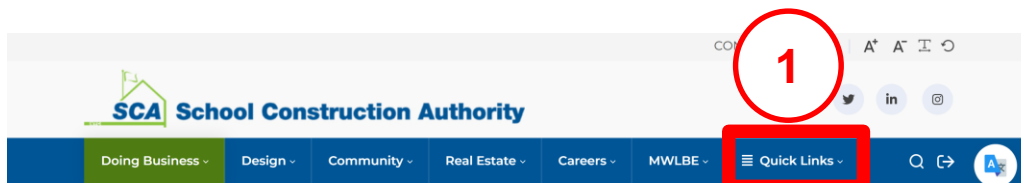

## DOB NOW: Build Submissions

All new submissions are done directly in DOB NOW and **must** indicate **SCA as owner type**. Please refer to the **DOB NOW-SCA Submissions Guide** for our special requirements. The following document types are required for all SCA filings:

- **SCA transmittal with LLW Number(s)**, email address for OneDrive access and all the filings, and drawings being uploaded and submitted.
- **Design Commission Approval City Owned / New York City Landmarks Preservation Commission Memorandum Letter.**

BCC job number will not be created until initial and all subsequent filings and completed drawings are submitted in DOB NOW. Once your submission is accepted and a BCC-job number and Plan Examiner is assigned, expect an email from **Microsoft OneDrive**. Save this email to collaborate on files and drawings with your Plan Examiner.

Partial submissions will not receive a BCC number or Examiner and be marked incomplete in DOB NOW and returned to the applicant for resubmission. The exception is new buildings and building additions requesting partial examination for Zoning Only.

This guide provided by DOB covers **Supersede** and **Withdrawal** requests.

## Working with BCC System

BCC System is used to track both new filings and older BIS filings. When your job has been **Disapproved**, an auto generated email will alert you. Find "red marks" on the drawings in your OneDrive folder. Login to BCC System to find objections and to track status. Use DOB NOW for resubmissions to appear on the Plan Examiner's BCC System Dashboard.

Use DOB NOW for resubmissions to appear on the Plan Examiner's BCC Dashboard.

Bidset

Obtaining Bid Information

Request for Qualifications and Expression

Advertised Bids

Limited Bids

Request for Proposal

SCA Connect

Vendor Access System

Public **2** Public Schools

LCMS 2.0 Training and Information

**SCA Plan Examinations**

# 2.1. Calendly Appointment

<http://www.nycsca.org/Doing-Business/SCA-Plan-Examination>

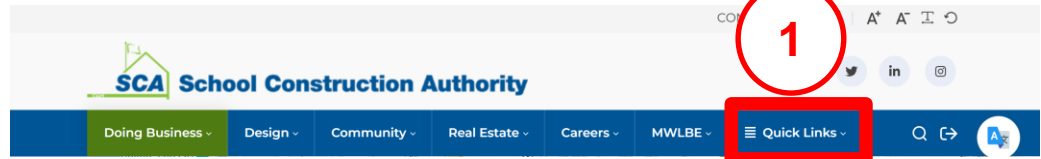

3

## SCA Plan Examinations

### SELF-SERVICE FOLLOW-UP PLAN EXAMINATIONS

Ariful Gaffar - agaffar@nycsca.org	calendly.com/025849	(718) 472-8528
Chris Brink - cbrink@nycsca.org	calendly.com/cbrink	(718) 752-5194
Ellen Dodson - edodson@nycsca.org	calendly.com/edodson-1	(718) 752-5594
Gabriela Arevalo - garevalo@nycsca.org	calendly.com/garevalo1	(718) 472-8362
Manoj Alex - malex@nycsca.org	calendly.com/malex	(718) 472-8793
Mark Villasin - mvillasin@nycsca.org	calendly.com/mvillasin	(718) 472-8487
Mohammad Saleh - msaleh@nycsca.org	calendly.com/msaleh-1	(718) 472-8449
Nadezda Gallas - ngallas@nycsca.org	calendly.com/ngallas	(718) 472-8735
Haiyan Chen - hchen3@nycsca.org	calendly.com/hchen3-nycsca	(718) 472-8252
Patrick Daly - pdaly@nycsca.org	calendly.com/pdaly-1	(718) 472-8655
Philip Killwey - pkillwey@nycsca.org	calendly.com/pkillwey	(718) 752-5613
Sang Oh Choo - schoo@nycsca.org	calendly.com/schoo-1	(718) 752-5461
Shihfeng Huang - shuang@nycsca.org	calendly.com/shhuang	(718) 472-8794
Yuliy Berezovskiy - yberezovskiy@nycsca.org	calendly.com/yberezovskiy	(718) 752-5654
Zheng Zhong - ZZHONG@nycsca.org	calendly.com/z_zhong	(718) 772-8609

Bidset

Obtaining Bid Information

Request for Qualifications and Expression

Advertised Bids

Limited Bids

Request for Proposal

SCA Connect

Vendor Access System

Public **2** Public Schools

LCMS 2.0 Training and Information

**SCA Plan Examinations**

# 2.2. BCC Guides, Procedures & Resources

<http://www.nycsca.org/Doing-Business/Environment-Regulatory-Compliance#Building-Code-Compliance-13>

The image shows a screenshot of the SCA website with several elements highlighted by red boxes and numbered callouts:

- 1**: The "Doing Business" menu item in the top navigation bar.
- 2**: The "Environment Regulatory Compliance" link in the main navigation menu.
- 3**: The "Building Code Compliance" link in the sub-menu.
- 4**: The "Guides and Procedures" section on the right-hand page.
- 5**: A list of guides and procedures on the left-hand page, with a red arrow pointing to the "Permit Exempt (Non-filed) Project Guide Video" item.

The list of guides and procedures includes:

- Fire Alarm Guide
- Fire Protection Plan Guide
- Permits Guide
- Public Assembly Guide
- Fire Suppression System Guide
- Permit Exempt (Non-filed) Project Guide Video
- Plan Exam Objection Response Video
- Support of Excavation Sheeting & Shoring Guide
- Temporary Fuel Storage Guide
- Concrete Procedures
- Resolving Violations Procedures
- (EQ) Fence Shed Scaffold Chute Guide

# 2.2. BCC Guides, Procedures & Resources

<http://www.nycsca.org/Doing-Business/Environment-Regulatory-Compliance#Building-Code-Compliance-13>

**1** Doing Business

**2** Environment Regulatory Compliance

**3** Building Code Compliance

**4** Resources

**5**

- BCC OG 2018-05 Electrical Letters
- BCC OG 2018-06 CID BCC Report Names
- BCC OG 2019-02 Close Out Documents Rev. 1
- BCC OG 2019-03 FDNY Access Prior Code Buildings
- BCC OG 2019-05 Owner Email
- BCC OG 2020-01 Certificate of Substantial Completion
- BCC OG 2020-02 Fire Protection Plans
- BCC OG 2020-03 Asbestos Close Out Procedure
- BCC OG 2022-01 Alternate Public Protection

# 2.2. BCC Guides, Procedures & Resources

<http://www.nycsca.org/Doing-Business/Environment-Regulatory-Compliance#Building-Code-Compliance-13>

The image shows a screenshot of the SCA website with several red annotations and boxes highlighting specific elements:

- 1**: A red circle around the SCA logo.
- 2**: A red circle around the "Environment Regulatory Compliance" link in the navigation menu.
- 3**: A red circle around the "Building Code Compliance" link in the sub-menu.
- 4**: A red circle around the number "4" in the "Resources" section, which is linked to the "Associated Documents" box.
- 5**: A red circle around the number "5" in the "Associated Documents" list.

The "Associated Documents" list includes:

- BCC Transmittal Form
- NYC Department of Building Application and Permitting Information
- Construction Equipment Removal Letter
- DOB NOW: Build Landmarks Exemption Memo

The "Resources" section includes:

- BCC Operational Guidelines
- Associated Documents

The "Building Code Compliance" section includes:

- Building Code Compliance
- Construction Inspection
- & Environmental Hygiene
- Safety

The "Environment Regulatory Compliance" section includes:

- Environment Regulatory Compliance

### 3. Submission Requirements

- Applicant will submit the project in **DOB NOW**
- Some projects are still **BIS** applications: BPP, Alt-1 No-Work.
- Jobs filed through BCC must be **Standard Plan Exam Review**. **NO** Directive 14.
- Always choose **Fee Exempt**
- **Leasing projects** (the owner is NOT SCA) should be filed/ reviewed by DOB directly, not BCC.

4. Filing Review Type\*

Standard Plan Examination ▼

5. Job/Project Types\*

Directive 14 acceptance requested ?  Yes  No

# 3.1. BCC Plan Exam Transmittal

- BCC Plan Exam Transmittal is **required**
- List name, email and phone number for all people who will need access to the OneDrive folder
- If a BCC# was previously assigned, make sure to add it to the transmittal

Required Documents			
Created On ↑	Document Name	Document Status	Prior To
7/13/2020 4:45 PM	Landmark Approval	Submitted	Approval
7/13/2020 4:45 PM	NYCSCA - BCC Plan Examination Transmittal	Submitted	Approval
7/13/2020 4:45 PM	Plans/Sketch - Mechanical Systems	Submitted	Approval
7/13/2020 4:45 PM	DEP ACP-20/ACP-21: Asbestos Project Conditional Co...	Required	Permit Issuance
7/13/2020 4:45 PM	DPL-1: Design Professional Seal & Signature	Submitted	Approval



NYC SCA BUILDING CODE COMPLIANCE (BCC) PLAN EXAMINATION  
Transmittal

School Name: (One Form for Each School)		Building ID: *	School Code:
School Address:			
LLW(s): *	Job Description	BCC Job # (if assigned)	

All emails listed will be invited to a OneDrive folder.  
Email [PlanReview@nycsca.org](mailto:PlanReview@nycsca.org) for troubleshooting.

Applicant: *	Email Address: *	Direct Line or Cell Phone: *
Filing Representative: *	Email Address: *	Direct Line or Cell Phone: *
Other Contact:	Email Address:	Direct Line or Cell Phone:
Other Contact:	Email Address:	Direct Line or Cell Phone:
Other Contact:	Email Address:	Direct Line or Cell Phone:
Other Contact:	Email Address:	Direct Line or Cell Phone:
Other Contact:	Email Address:	Direct Line or Cell Phone:
Other Contact:	Email Address:	Direct Line or Cell Phone:
Other Contact:	Email Address:	Direct Line or Cell Phone:

Notes:

**Appointment Instructions:**

- Appointments scheduled with "Calendly" only if necessary. Links are here: <http://www.nycsca.org/Doing-Business/SCA-Plan-Examination>.
- Typically resubmissions do **not** require an appointment.
- Appointment can be **cancelled** if examiner has determined an appointment is not required.
- Applicants are responsible for changing or canceling appointments by using "Calendly."
- Please be considerate of the examiners time.
- Applicants must resubmit revised drawings and other documents with a detailed A11 listing drawing numbers and objections response to OneDrive **prior** to the appointment.

## 3.2. SCA Owner Info

- Building Owner is the Borough CPO

First	Last	Chief Project Officer	Official Email Address for DOB NOW
Robert	Murphy	Staten Island	<a href="mailto:SCAOWNER-S@NYCSCA.ORG">SCAOWNER-S@NYCSCA.ORG</a>
Dean	Johanson	Manhattan	<a href="mailto:SCAOWNER-M@NYCSCA.ORG">SCAOWNER-M@NYCSCA.ORG</a>
Colin	Albert	Brooklyn	<a href="mailto:SCAOWNER-B@NYCSCA.ORG">SCAOWNER-B@NYCSCA.ORG</a>
Gordon	Tung	Bronx	<a href="mailto:SCAOWNER-X@NYCSCA.ORG">SCAOWNER-X@NYCSCA.ORG</a>
Joseph	Scalisi	Queens	<a href="mailto:SCAOWNER-Q@NYCSCA.ORG">SCAOWNER-Q@NYCSCA.ORG</a>

Owner Information\*

Email*	Owner Type*	Name*
SCAOWNER-Q@NYCSCA.ORG	School Construction Authority	JOSEPH SCALISI
Relationship to Owner	Business Name/Agency Name*	Street Address*
CHIEF PROJECT OFFICER	NYC SCHOOL CONSTRUCTION AUTHORITY	25-01 Jackson Avenue
City*	State*	Zip Code*
LONG ISLAND CITY	NY	11101
Telephone Number		
7184728603		
Is the deed holder a non-profit organization?*		
<input type="radio"/> Yes <input checked="" type="radio"/> No		

# 3.3. Property Ownership Certification

- Property ownership certification is **NOT** required when owner type is SCA
- Applicant should upload the Service Notice dated 8/10/2021 into DOB NOW: Document



August 10, 2021

## SERVICE NOTICE

### New Required Document in DOB NOW: *Build* – Property Ownership Certification ([Local Law 160 of 2017](#))

Beginning August 16, 2021, for jobs created on or after August 16, 2021, applications for New Building and Alteration-CO in DOB NOW: *Build* will require a [Property Ownership Certification Form](#) to proceed with a permit request.

#### Who is required to submit the Property Ownership Certification form?

All applicants for a New Building (NB) or Alteration-CO (Alt-CO), except for those listed below, must submit the form.

Exceptions:

- jobs on government-owned properties
- an application filed by a tenant for work to be performed in a unit or space occupied by the tenant

The [Property Ownership Certification form will not be listed in the DOB NOW: \*Build\* Documents section for applications that have the Owner Type as NYC Agency, NYCHA/HHC, Other Government Owned and Operated or \[School Construction Authority\]\(#\). For work by a tenant on a tenant-occupied space, the owner must select in the \*\*Owner Arrears\*\* part of the \*\*Statements & Signatures\*\* section of the filing, this Exception: a portion of the property is occupied by a tenant who is not an owner of the property or responsible for any covered arrears owed with respect to the property. The form will be listed in the Documents section of the filing, and the applicant should select \[Request Waiver from the Action column for the Property Ownership Certification form\]\(#\).](#)

# 3.4. Fee Exempt Document

- Upload latest DOF ACRIS Report
- <https://a836-acris.nyc.gov/CP/>

Required Documents*		
Document Name ▲	Document Status ▼	Prior To ▲ ▼
Design Commission Approval City Owned (Exterior Work)	Prefiling Waiver Requested	Approval
Design Commission Sign Off City Owned (Exterior Work)	Required	Letter of Completion
DPL-1: Design Professional Seal & Signature	Pending	Approval
Fee Exempt Supporting Document: DOF ACRIS Report or BIB letter	Pending	Approval
Plans/Sketch - Sidewalk Shed	Pending	Approval

NYC Finance

**70 -02 54 AVENUE** Borough: QUEENS  
Block: 2503 Lot: 31

**2020 - 2021 Final Assessment**

Final Assessment Roll for 2020-2021 | City of New York  
Taxable Status Date January 5, 2020

**EXPLANATION OF ASSESSMENT ROLL**

Owner Name DEPARTMENT OF EDUCATION  
Property Address 70 -02 54 AVENUE 11378  
Billing Name and Address DEPARTMENT OF EDUCATION

119 W. 23RD ST. STE 903  
NEW YORK NY 10011-6342

Tax Class 4  
Building Class W1 - PUBLIC ELEMENTARY, JUNIOR OR SENIOR HIGH

**Property Owner(s)**  
DEPARTMENT OF EDUCATION

**Land Information**

Lot Size  
Frontage (feet) 204.00  
Depth (feet) 538.00  
Land Area (sqft) 100,000  
Regular / Irregular Irregular

Number of Buildings 1  
Building Size  
Frontage (feet) 170.00  
Depth (feet) 330.00  
Stories 4  
Extension N

**Assessment Information**

Description	Land	Total
ESTIMATED MARKET VALUE	3,920,000	24,244,000
MARKET AV	1,764,000	10,909,800
MARKET EX		10,909,800
TRANS AV	1,764,000	10,071,720
TRANS EX		10,071,720

**Taxable/Billable Assessed Value**

Assessed Value 0

Subject To Adjustments, Your 2020/21 Taxes Will Be Based On

**Exemption Information**

Code	Description	Exempt Value
13356	PARKS DEPT NYC	10,909,800

**Market Value History**

Tax Year	Market Value
2020 - 2021	24,244,000
2019 - 2020	23,529,000
2018 - 2019	23,529,000

# 3.5. Public Design Commission/ Landmarks

- Do **NOT** request waivers/or deferrals for Design Commission Approval City Owned (Exterior Work) OR Landmark
- Upload the Memorandum Letter for both items
- Enter the word “School” for Landmark approval #

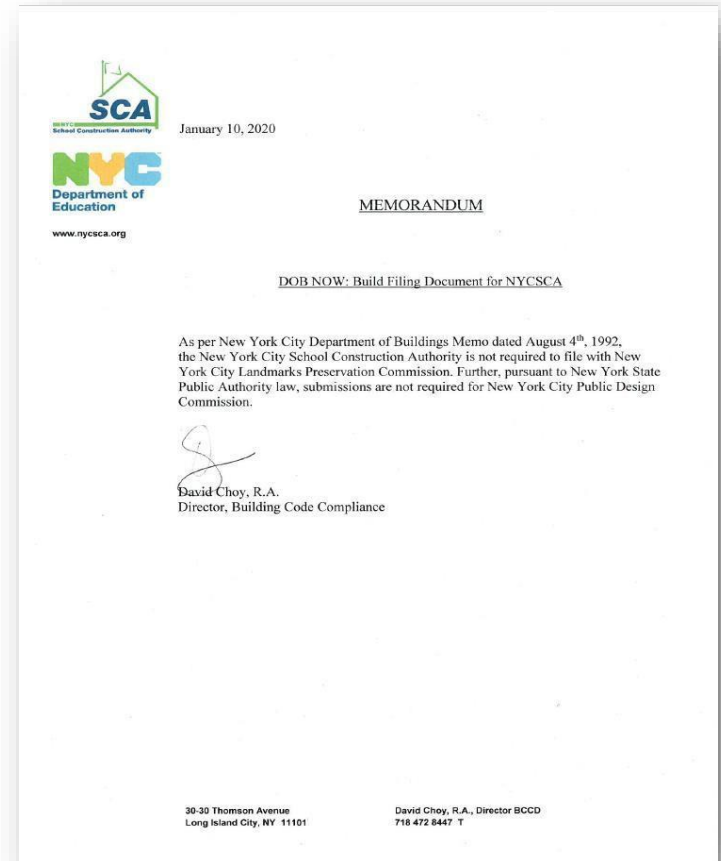

Additional Considerations, Limitations or Restrictions	
Landmark*	Landmark approval number*
L - LANDMARK	SCHOOL

# 3.6. TR4/ Soil Report

- Soil report and TR4 are required **prior to approval** for all SCA jobs (NB, Alt-CO, Alt) required boring.
- Applicant of boring drawings must be matched with applicant on TR4
- TR4 section 3 must show the borings and the test pits to match the report
- TR4 must be **flattened**. Editable version (with blue fills) would be rejected because it would crash examiners' computer.
- TR4 & TR1 (Initial & final) for "Boring/test pits" must be submitted by the same applicant.

**NYC BUILDINGS** TR4: Technical Report  
Soil Investigation  
*Must be typewritten.*

Orient and affix BIS job number label here

**1 Location Information** *Required for all applications.*

House No(s) Street Name  
Borough Block Lot BIN CB No.  
Work on Floor(s) Apt/Condo No(s)

**2 Applicant Information** *Required for all applications.*

Last Name First Name Middle Initial  
Business Name Business Telephone  
Business Address Business Fax  
City State Zip Mobile Telephone  
E-Mail License Number  
 P.E.  R.A.

**3 Required Borings / Test Pits** *Required for all applications.*

Number of Test Pits as Required as per NYC Construction Codes:

**NYC BUILDINGS** TR4: Technical Report  
Soil Investigation  
*Must be typewritten.*

Orient and affix BIS job number label here  X00678506

**1 Location Information** *Required for all applications.*

House No(s) 120 Street Name Anderson Ave  
Borough Bronx Block 2504 82 BIN CB No.  
Work on Floor(s) OSP (Open Space) Apt/Condo No(s)

**2 Applicant Information** *Required for all applications.*

Last Name En Huei First Name Joe Middle Initial  
Business Name YU & Associates, Inc. Business Telephone (201)791-0075  
Business Address 200 Riverfront Boulevard Business Fax (201)791-4533  
City Elmwood Park State NJ Zip 07407 Mobile Telephone (201) 815-0699  
E-Mail jmartinez@yu-associates.com License Number 069402  
 P.E.  R.A.

**3 Required Borings / Test Pits** *Required for all applications.*

Number of Test Pits as Required as per NYC Construction Codes: 3 Borings

## 3.7. Asbestos

- Always select **DEP Variance (V5) Letter** for all filings unless
  - ACP5 has been submitted or
  - Exempt from asbestos requirements
- If any changes are required on the asbestos submission, A PAA is required for the I1 application and **ALL** other subsequent filings/ work types
- No PAA is required for PW1 change from V5 to ACP20/21. Applicant can simply upload ACP21 as required documents of V5 prior to permit and ACP20/21 prior to LOC.\*

Required Documents*		
Document Name ▲	Document Status ▼	Prior To ▲
DEP ACP-20/ACP-21: Asbestos Project Conditional Completion Form/Asbestos	Submitted	LOC Issuance
DEP Variance (V5) letter	Accepted	Permit Issuance
Design Commission Approval City Owned (Exterior Work)	Accepted	Approval
Design Commission Sign Off City Owned (Exterior Work)	Required	LOC/CofO

\*Update: December 2024

## 3.8. Artwork on EQ's

- Applicant (not owner) to select “Yes” on question 11
- Select “Capital funding” on question 12
- Refer to LL 163 of 2021
- <https://www.nyc.gov/assets/buildings/pdf/ll163artwork-sn.pdf>

### Artwork on Temporary Protective Structures

11. Are you opting out of the requirement to install artwork on temporary protective structures (sidewalk sheds, construction fences, and supported scaffolds that have been installed for at least 90 days)? If no is selected, an approval letter from the NYC Department of Cultural Affairs (DCLA) will be a Required Document. (NYC Building Code 3307.11)\*

Yes  No

12. Reason: (select one)\*

~~Property is City-owned and funding has not been appropriated for the display of artwork.~~

Project receives capital funding from New York City and funding has not been appropriated for the display of artwork.

The DCLA City Canvas art program has not yet been implemented.

The proposed alternative artwork has not yet been approved by DCLA.

Other

# 3.9. DHCR

- DHCR flag “Yes” indicates the building contains at least **one rent-regulated unit** identified by NYS Homes and Community Renewal (HCR)
- DHCR Document is required when DHCR flag “Yes” and the applicant answers “No” on PW1 section 26.
- DHCR Document Waiver or deferral is **NOT** permitted in DOB NOW.
- Applicant to upload AI1 with a statement “Scope of work is only in school portion. DHCR is not applicable for SCA project portion”
- AI1 with the statement will satisfy DHCR Document requirement.

NYC Department of Buildings  
Property Profile Overview

<b>30-90 14 STREET</b>	<b>QUEENS 11102</b>	<b>BIN# 4005712</b>
14 STREET	30-90 - 30-90	Health Area : 300
		Census Tract : 79
		Community Board : 401
		Buildings on Lot : 1
<a href="#">View DCP Addresses...</a>	<a href="#">Browse Block</a>	Tax Block : 517
		Tax Lot : 6
		Condo : NO
		Vacant : NO
<a href="#">View Zoning Documents</a>	<a href="#">View Challenge Results</a>	<a href="#">Pre - BIS PA</a>
		<a href="#">View Certificates of Occupancy</a>
Cross Street(s):	30 DRIVE, 31 AVENUE	
DOB Special Place Name:		
DOB Building Remarks:		
Landmark Status:		Special Status: N/A
Local Law:	NO	Loft Law: NO
SRO Restricted:	NO	TA Restricted: NO
UB Restricted:	NO	DOT Protected Street: N/A
Environmental Restrictions:	N/A	Grandfathered Sign: NO
Legal Adult Use:	NO	City Owned: NO
<b>DHCR Flag:</b>	<b>YES</b>	DHCR Number of Units: 0017
RRP Work:	NO	BIB Work: No
Additional BINs for Building:	NONE	

Document Name	Applicable Work Type(s)	Prior to Stage	Waiver	Deferral
DHCR Document	All Work Types	Filing	No	No



# 3.10. HPD-2

- HPD2: Clinton Special District Anti-Harassment checklist
- Section 3: Select “ Other area within Clinton Special District”
- Complete section 1, 2, 3, 7 and upload the form into DOB NOW: Document
- This form must be flattened before it is submitted.



## HPD2: Clinton Special District Anti-Harassment Checklist

Form must be typewritten

Job No. \_\_\_\_\_

### 1 LOCATION INFORMATION *(required for all applications)*

House No(s)	Street Name	Work Proposed on Floor No(s)		
Borough	Block	Lot	BIN	CB No.

### 2 APPLICANT OF RECORD *(required for all applications)*

Last Name	First Name	Middle Initial
Business Name		Business Phone
Business Address		Business Fax
City	State	Zip
Mobile Phone		License Number
Email	<input type="checkbox"/> PE <input type="checkbox"/> RA	

### 3 CLINTON SPECIAL DISTRICT LOCATION *(check area that applies)*

- Preservation Area *(complete Sections 4, 5 and 7 only)*
- Perimeter Area *(complete Sections 4, 6 and 7 only)*
- Other area within Clinton Special District, therefore exempt from requirements in Sections 4, 5 and 6, go directly to Section 7.



## 4. Submission Process

- **Application Processing Unit (APU)** – Reviews that all information is accurate on documents & plans and all subsequent applications are submitted. (PW1, plans, energy drawings, transmittal, etc.).
- BCC job number will **NOT** be created until **initial and all subsequent filings and completed plan sets** are submitted in DOB NOW.
- Partial submissions will **NOT** receive a BCC# or Examiner and will be marked incomplete in DOB NOW and returned to the applicant for resubmission. The **exception** is NB and Addition (Alt-CO) applications requesting partial examination for **Zoning & Egress Review Only**.
- All plans must include **DOB NOW job#** with the extension (I1, S1, S2...)

# 4. Submission Process

## DOB NOW

- Once your DOBNOW submission is accepted, a **BCC# & Examiner** will be assigned and an email notification is sent to all stakeholders on the PW1 (AOR/filing rep). A **OneDrive link** is sent to all stakeholders listed on the transmittal.
- Application Processing Unit will upload DOBNOW documents (drawings, Transmittal and the PW-1) into the OneDrive folder.

## BIS

- BIS applications (Builders paving plan, ALT1 no work)
- Applicant submits in BIS and sends email to Planreview with one forms PDF and one drawings PDF.
- Once your BIS submission is accepted, a **BCC# & Examiner** will be assigned and an email notification is sent to all stakeholders on the PW1 (AOR/filing rep). A **OneDrive link** is sent to all stakeholders listed on the transmittal.
- Planreview will upload The two PDF documents (drawings and the forms) into the OneDrive folder.

# 4. Submission Process

Once complete submission is accepted, you will receive:

- Confirmation from BccNotification@nycsca.org
- OneDrive Link

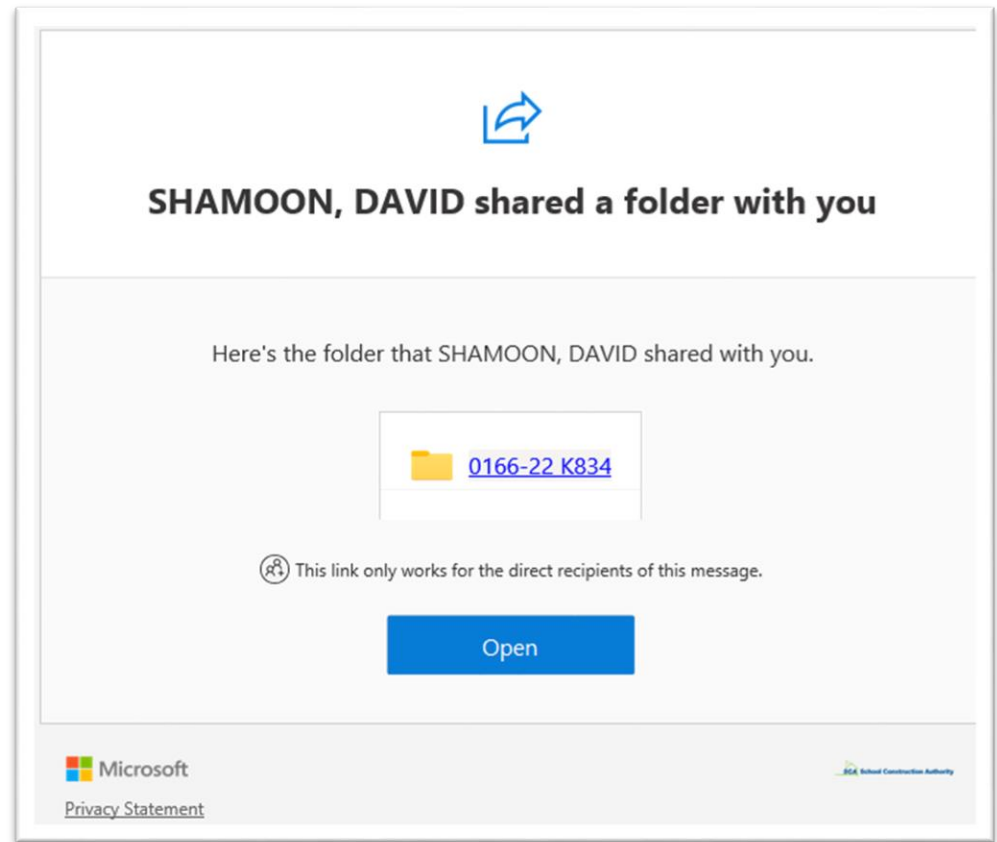
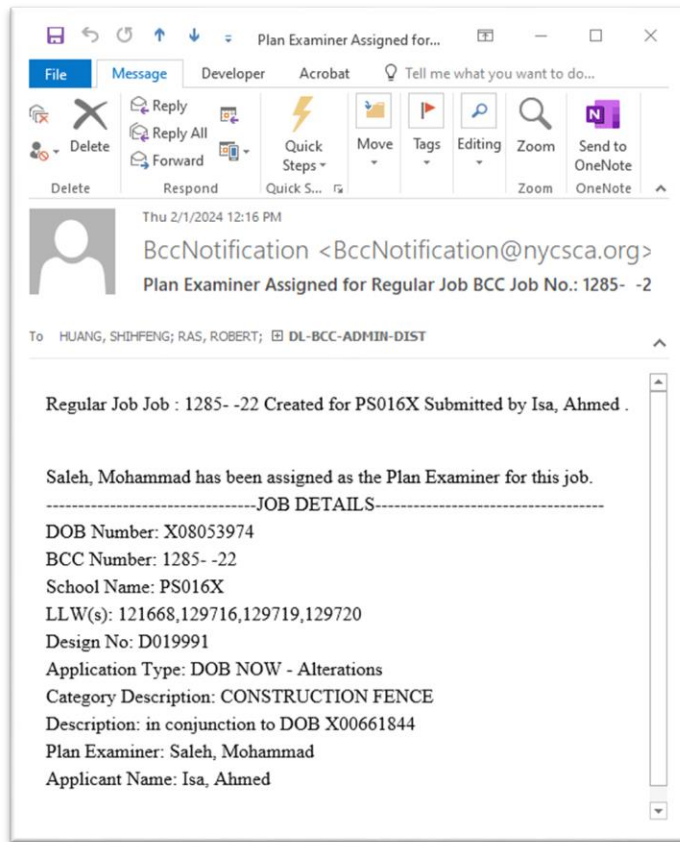

# 4.1. OneDrive Folder Structure

## 4.1.1. DOB NOW/ BIS: Initial Submission

- Application Process Unit to create Initial folders and to upload the documents
- Folder naming structure: BCC job# + Bldg ID + Filing type (No change on current folder naming structure)

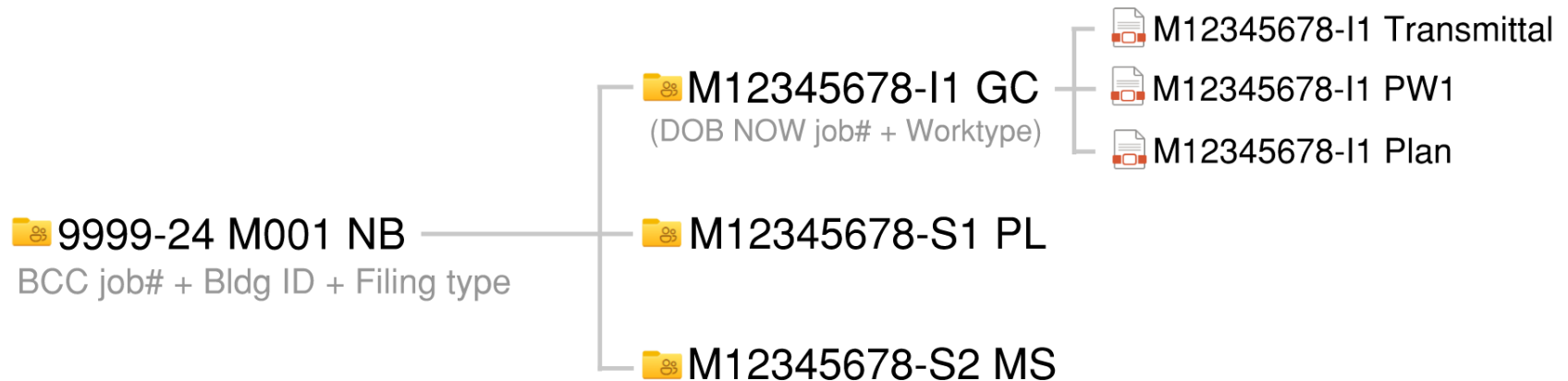

# 4.1. OneDrive Folder Structure

## 4.1.2. DOB NOW/ BIS: Plan Review

- Examiner to save Markups in the folders

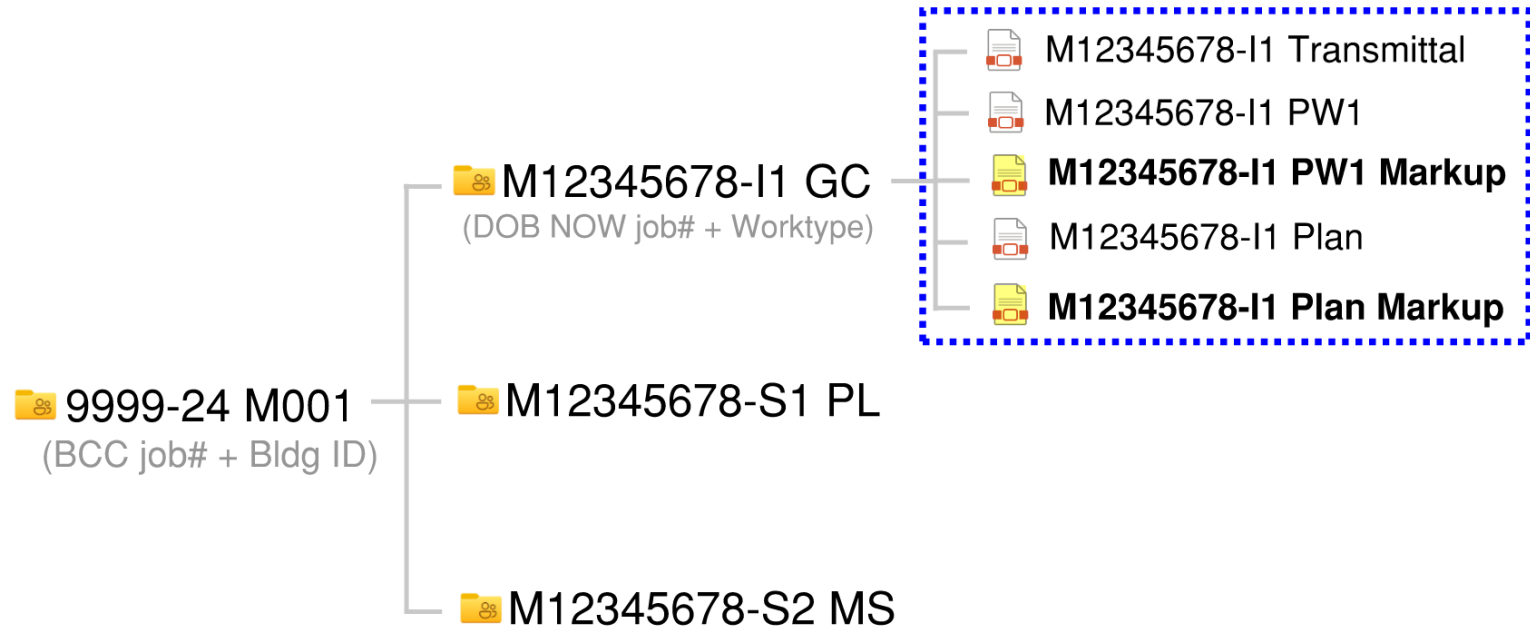

# 4.1. OneDrive Folder Structure

## 4.1.3. DOB NOW/ BIS: 1st Resubmission

 Applicant/ Expeditor to create **"Archive" folder** and to relocate the outdated files to the Archive folder

- It is recommended Applicant/ Expeditor to create sub-folders in the Archive folder
- If examiner is unable to find plans/ documents for this resubmission, s/he will disapprove the job in BCC 2.0 without review.

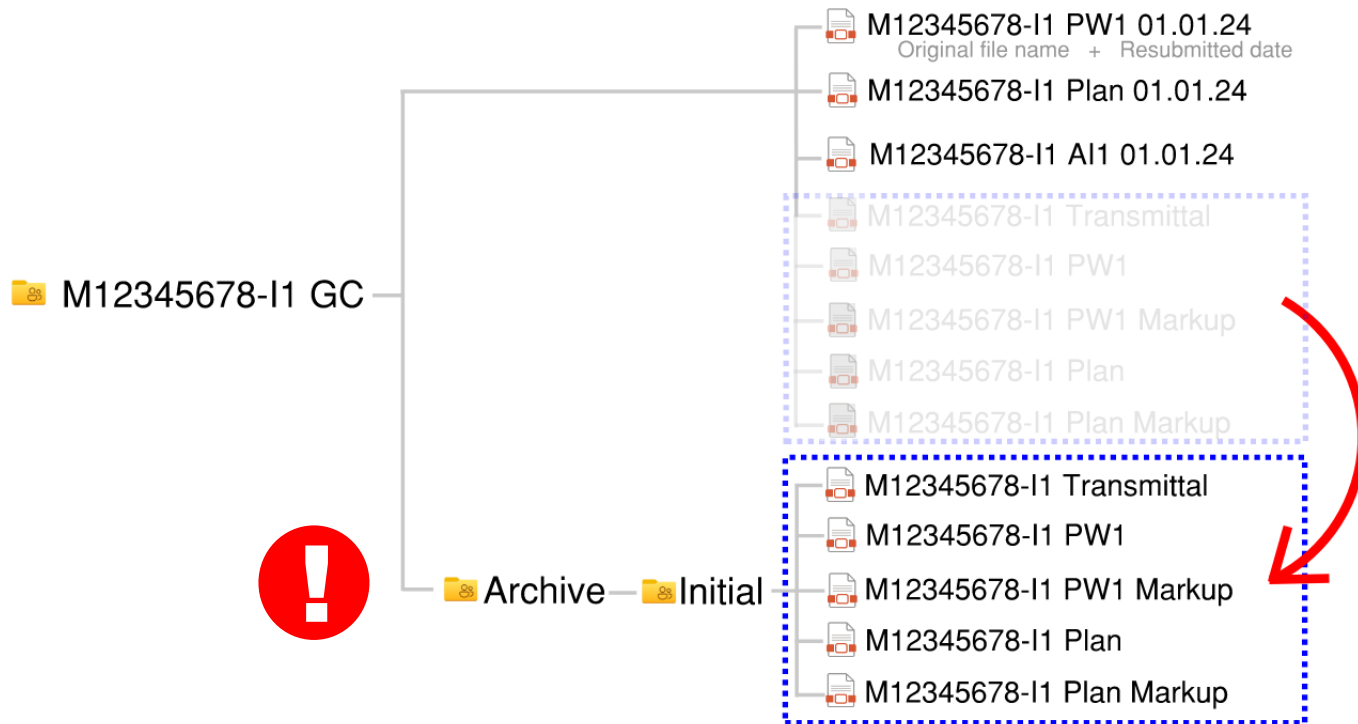

# 4.1. OneDrive Folder Structure

## 4.1.4. DOB NOW/ BIS: Plan Review for 1st Resubmission

- Examiner to save Markups in the folders (if applicable)

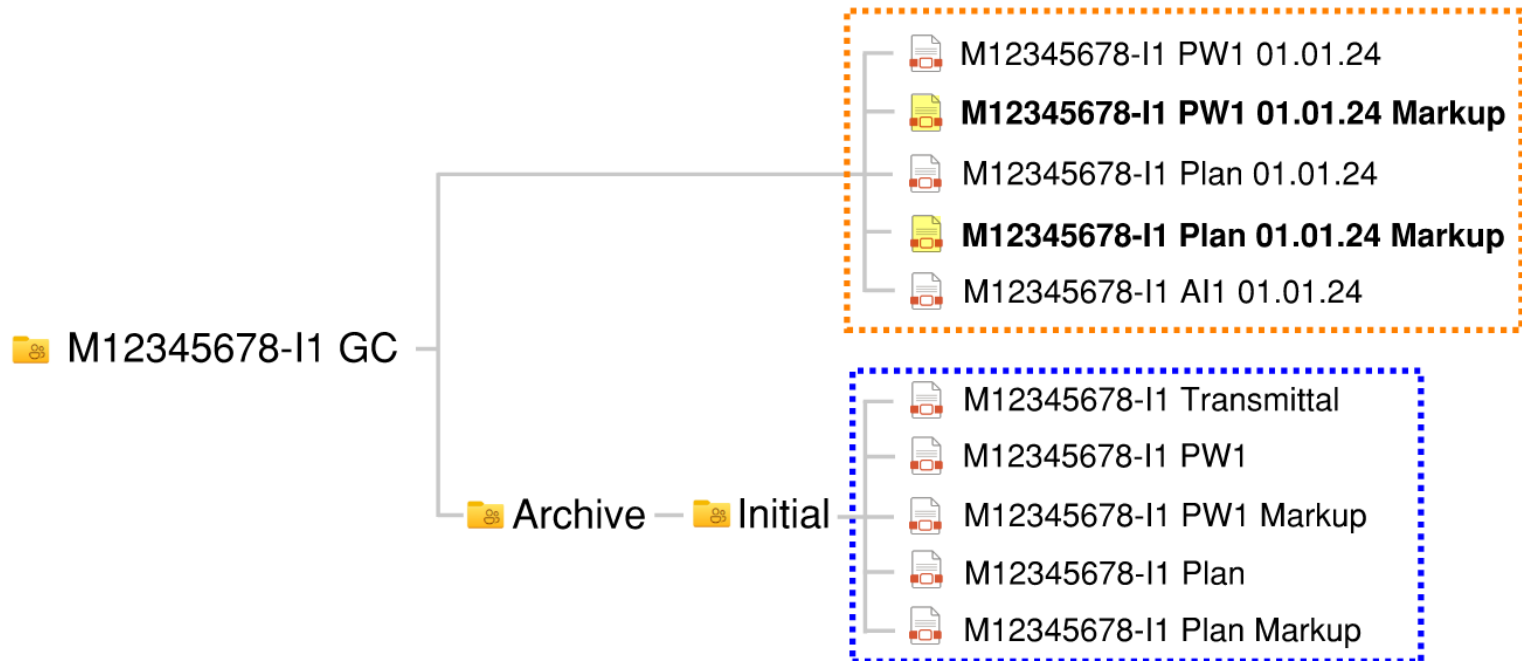

# 4.1. OneDrive Folder Structure

## 4.1.4. DOB NOW/ BIS: 2<sup>nd</sup> Resubmission



Applicant/ Expeditor to relocate the outdated files to the Archive folder

It is recommended Applicant/ Expeditor to create sub-folders in the Archive folder

- If examiner is unable to find plans/ documents for this resubmission, they will disapprove the job in BCC 2.0 without review.

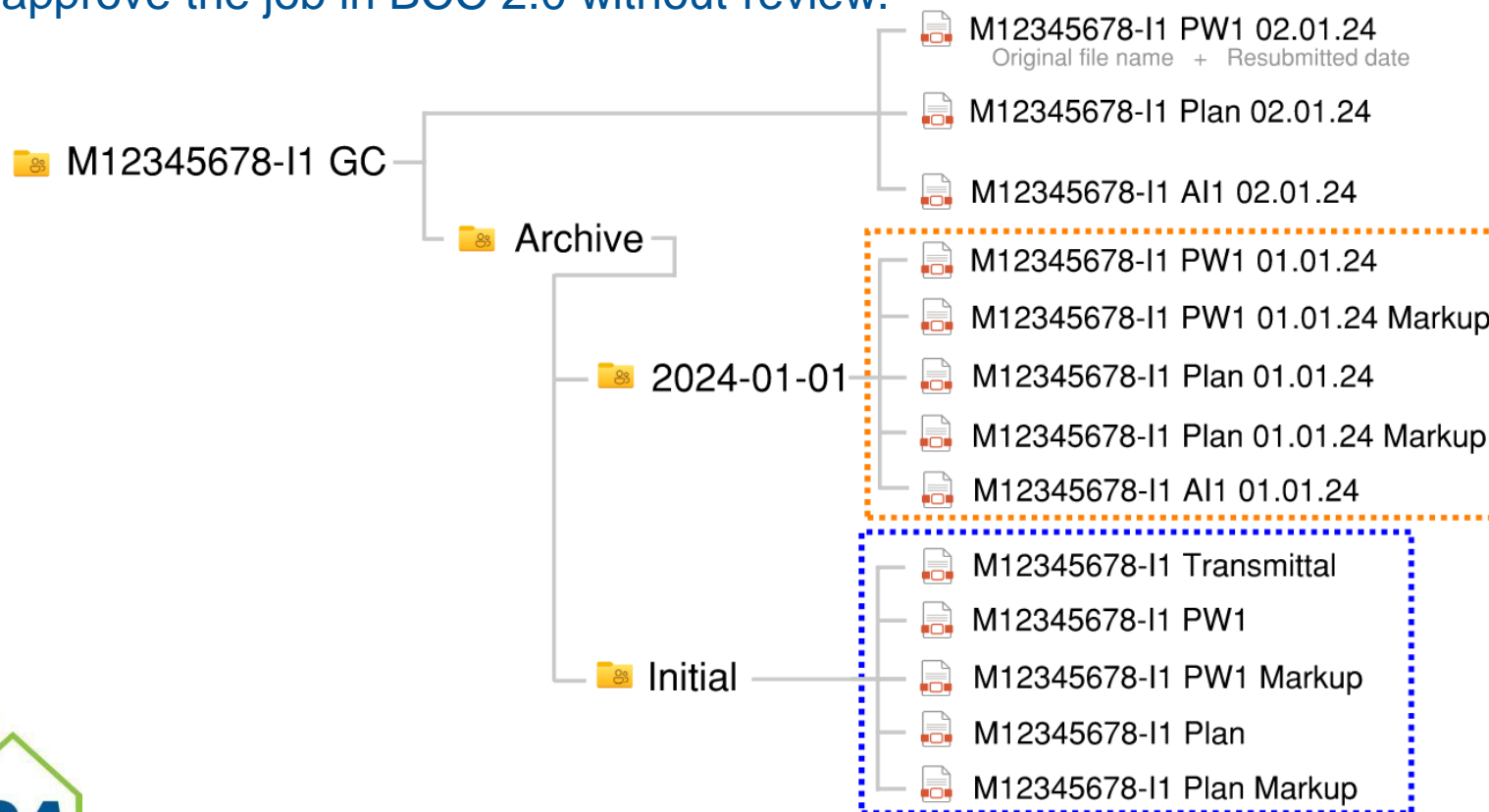

# 4.1. OneDrive Folder Structure

## 4.1.5. DOB NOW: PAA

- Same rules above apply to DOB NOW PAA

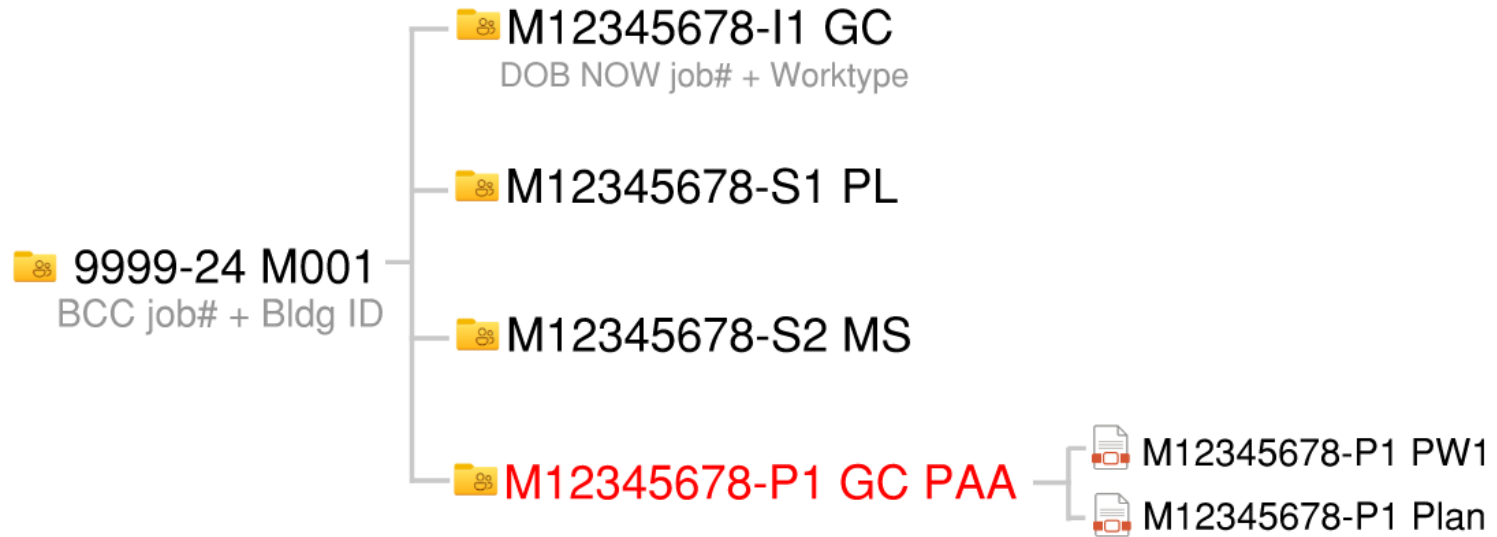

# 4.1. OneDrive Folder Structure

## 4.1.6. BIS: PAA

- Same rules apply to BIS PAA
- The only difference is the folder naming structure

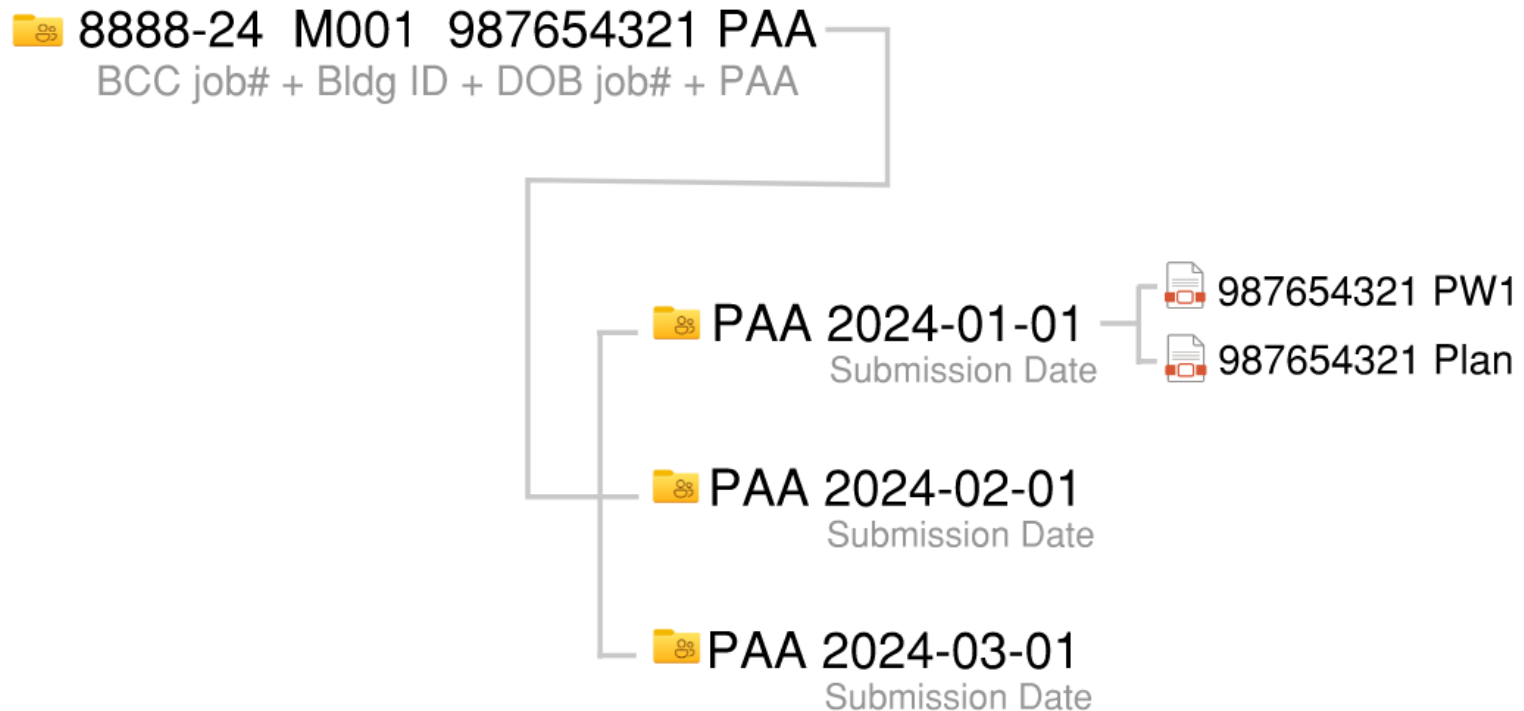

# 5. Plan Review

- When the submission is accepted by the Application Processing Unit or Plan Review Unit, the project is assigned to a BCC Plan Examiner.
- The project will be reviewed for compliance with the 2022 NYC Construction Codes, Zoning Resolutions and all applicable Rules and Procedures.
- When the work is to be done in phases the temporary egress plans must include all of the work phases. Refer to [BCC Temp Egress Plan Procedure](#).
- After the objections are issued and red marks have been added to the drawings and forms in the OneDrive folder the Plan Examiner will process the application in both the BCC system and the DOB NOW system. Applications filed in BIS will only be processed in the BCC system. All of the other checklists on the status report will also be populated at this time.

# 5. Plan Review

- Applicant must refer to the BCC Report:
  - Plan Approval Checklist for comments
  - Objection Checklist for objections
- For NB and Alt-1 applications, the applicant must also refer to the BCC Report: Approval Checklist

**1**

BCC Building Code Compliance

Objections Checklist

Save Cancel Manage Checklist Print

**JOB INFO**

School ID: P.S. 116  
Building ID: M098 Borough: Manhattan  
Address: 508 West 212th Street  
Block/Lot/Bin: 2229/112/1064871

Job No: 0916--23 DOB No: M00951887 App. Type: DOB NOW - Alterations  
Category Description: GENERAL CONSTRUCTION  
Design: D022054 Package: N/A SHPO: Flood Hazard: Open Objections: 2 of 31  
LLW: 133346 134067 Const. Inspector: N/A  
Review: Full Review Description: Mini-Building Removal (to be filed separately by contractor) and playground redevelopment.

**DISTRIBUTION**

Lead Applicant: Caravella, Robert  
Plan Examiner: Kilwey, Philip  
Close-out Inspector: Providence, David  
Project Officer: EKUNDAYO ALAMUTU PO Ext:

Seq	Objection Description	Current Status	Updated Date	Reason	Comment
1	APPLICATION (PLANS): 28-104.7.1 - DRAWING IS INCOMPLETE AND/OR UNCLEAR IN THAT: SEE REDMARKS ON PLANS UPLOADED TO THE ONEDRIVE FOLDER.	OPEN			
2	APPLICATION (PLANS): BC 28-104.7.1 - THE DRAWING LIST ON THE TITLE SHEET DOES NOT MATCH THE SUBMITTED DRAWINGS, IN THAT: DRAWING COUNT IS INCORRECT.	COMPLETED	06/26/2024		

**1**

BCC Building Code Compliance

Plan Approval

Save Cancel Print

**JOB INFO**

School ID: P.S. 116  
Building ID: M098 Borough: Manhattan  
Address: 508 West 212th Street  
Block/Lot/Bin: 2229/112/1064871

Job No: 0916--23 DOB No: M00951887 App. Type: DOB NOW - Alterations  
Category Description: GENERAL CONSTRUCTION  
Design: D022054 Package: N/A SHPO: Flood Hazard: Open Objections: 2 of 31  
LLW: 133346 134067 Const. Inspector: N/A  
Review: Full Review Description: Mini-Building Removal (to be filed separately by contractor) and playground redevelopment.

**DISTRIBUTION**

Lead Applicant: Caravella, Robert  
Plan Examiner: Kilwey, Philip  
Close-out Inspector: Providence, David  
Project Officer: EKUNDAYO ALAMUTU PO Ext:

Bid Review: No Full Self-Certification: No Objection Self-Certification: No Full Review: Yes

Seq. No.	Received	Assigned	Reviewed	Status	Comment	Filing Type	Examiner	Status U...
3	03/28/2024	03/28/2024	04/04/2024	Code Co	Resubmission 3/27/24 is incomplete. All markups have not been corrected. OneDrive folder is missing the revised PW-1 form	Initial Filing	Philip J Kilwey	Philip J Kilwey

**2**

## 6. Resubmission

- **OneDrive** folder is used to resubmit revised drawings PDF, revised PW-1 PDF with response to objections (AI-1) PDF and or back/forth communications with the examiner.
- All forms/documentations and plans submitted on OneDrive must be **flattened** to process in Bluebeam.
- When uploading new documents to the OneDrive folder Organize the **latest** documentations in the current folder. Move outdated documentations into an archive folder to distinguish the new documents from the previous documents.
- See 4.1 OneDrive Folder Structure.

## 6. Resubmission

- During resubmission, the **plans** should be re-submitted by the applicant in the **OneDrive ONLY**. **NO** plans should be uploaded in DOB NOW regardless of any plan changes.
- If the **PW-1** is revised in DOB NOW, a PDF must be added to the OneDrive folder for the second review.
- An **AI-1** must be provided responding to the objections and clearly indicating detail, note number or drawing number, (e.g., **See sheet A101, General Note, item 5 for the note.**) No plan review can be performed without the completed AI-1 responses.

 Applicant must click the **SUBMIT** button in DOB NOW for resubmission.

## 6. Resubmission

- When the application is resubmitted in the DOB NOW the Applications Processing Unit (APU) will add the application to the Plan examiners dashboard under resubmission in review.
- The Plan Examiner will review the documents, update the BCC report and either approve or disapprove the application in BCC and DOB NOW.
- If the application is disapproved the applicant will repeat the resubmission process.

# 6. Resubmission

- **Frequent issues during resubmission:**
  - Applicant must click the SUBMIT button in DOB NOW for resubmission
  - Applicant must upload the latest **Drawings, PW1**, and **AI1** in the OneDrive for review
  - Special Inspections on drawings do not match with PW1
  - PW1-Schedule A and B do not match with the drawings
  - Do NOT wait for PW1 revision at the last minute
  - DOB job# is missing/ or incorrect on drawings/ AI1
  - Request archive drawings/ background information from A&E
  - PW1 Mechanical Scope of Work is not complete and does not match the drawing.

# 6. Resubmission

- Frequent issues during resubmission:



Any additional supporting documents, should be combined as one PDF file and upload with transmittal, e.g., AI1

- When uploading Required Documents, always select DOB NOW designated document name
- Do **NOT** select “Other Documents” and create new document name
- Do **NOT** upload Plan/Sketch under “Other Documents”

Additional Supporting Documents					Required Documents				
Created On	Document Name	Docume...	Prior To		Created On	Document Type	Docume...	Prior To	
3/29/2023 2:01 PM	Other Documents - Backflow Prevention Asses	Accepted	Approval		9/29/2022 3:55 PM	House Number Verification: TC	Submitted	CofO	
3/29/2023 2:03 PM	Other Documents - Vitrinite APVL for Grease an	Accepted	Approval		9/29/2022 3:55 PM	Street Tree Site Plan	Submitted	CofO	
4/3/2023 1:37 PM	Other Documents - Boring and Soil Report	Accepted	Approval		9/29/2022 3:55 PM	Final Survey	Required	CofO	
4/3/2023 1:38 PM	Other Documents - Detention System Design.	Accepted	Approval		9/29/2022 3:55 PM	NYSCSA Exhibit 2	Required	LOC Issuance	

# 7. Appointment

- This is a fully electronic process and typically resubmissions do **NOT** require an appointment.
- Applicants who would like to make an appointment can schedule online with **Calendly**. All appointments are conducted over **Microsoft Teams**
- Appointments can be canceled by an examiner if they determine an appointment is not required.
- Applicants are responsible for changing or canceling appointments by using “Calendly.” Please be considerate of the Examiners time.
-  Applicants must resubmit revised drawings, PW-1 and other documents with a detailed **AI-1** listing drawing numbers and objections response to the OneDrive folder at least one day prior to the appointment.
- Requests for **expedited** appointments should be made by an SCA Design Manager (DM), SCA Design Project Manager (DPM), or by working with BCC management.

## 8. Approval

- **Plans** - When the application is ready to approve, submit **separate** plan set PDF for each filing (I1, S1, S2, etc.) in order for the examiner to approve accordingly. The **EN** drawings must be filed as a separate plan set PDF for each associated applicable application.
- **Supporting Documents** - When the application is ready to approve, submit **ONE** PDF file including all supporting documentations (if applicable).
- The Plan examiner will approve the drawings and upload them into the DOB NOW. The drawings and the supporting documents will also be sent to the Application Processing Unit (APU) for uploading to Edocs.
- The Project Officer can download the approved documents from Edocs as needed.
- The applicant can download the approved documents from DOB NOW.

# 9. Post Approval Amendment (PAA)

**BIS jobs:** Email [PLANREVIEW@nycsca.org](mailto:PLANREVIEW@nycsca.org) for BIS filed Post Approval Amendments

- Any BIS PAA should include a BCC transmittal, drawings, PW1, AI1 and/or additional required forms. Documents will be uploaded to the OneDrive by Planreview. A OneDrive link is sent to all stakeholders listed on the transmittal.
- When adding or deleting a Special Inspection, provide a PW1 and indicate the Special Inspection change in the section 24 comment box. A revised TR1 is **not** required.
- When BIS PAA is Disapproved the plan examiner will issue comments in the BCC system: Plan Approval Checklist.
- The BCC system will send an automatic email to the applicant of record regarding approval and/or disapproval.
- If PAA is disapproved, the applicant shall resolve issues and upload the corrected forms and drawings to the OneDrive folder.
- All resubmissions must be sent to the PlanReview mailbox. Do **NOT** email Examiner directly.

# 9. Post Approval Amendment (PAA)

**DOB NOW jobs:** Must use **DOB NOW** for PAAs

- Once your DOBNOW PAA is submitted the application Processing unit will add the application to the examiner's dashboard.
- The applicant must upload DOB NOW documents (drawings and the PW-1) into the OneDrive folder.
- One PDF for the **Drawings** & one PDF for the **PW1** and **AI1** form. AI1 to list all detailed changes.
- Job# for PAA shall be recorded as B00000000-**P1**, not B00000000-I1
- The BCC system will send an automatic email to the applicant of record regarding approval and/or disapproval.

**Question: For a PAA, if I am only revising one sheet, do I need to upload a complete set or just the one sheet?**

Only revised sheet(s). BCC will keep the process the same for BIS and DOB NOW at the SCA and accept **only amended drawings** for PAA's. (this DOB FAQ is not applicable for SCA jobs) The previously approved drawings that are unaltered remain in force.

# 10. Withdrawal: Filing & PAA

When the project (with DOB NOW#) has been filed with BCC:

- Email [PERMITS@NYCSCA.ORG](mailto:PERMITS@NYCSCA.ORG) with copy of the **withdrawal form** including **AI1** with the reason to withdraw
- The Application Processing Unit (APU) will send the form to the examiner and add it to their dashboard
- Only Owner's signature needs to be provided to withdraw filing
- The examiner will review and process the approval/disapproval in the Plan Approval Checklist in BCC system
- An auto email will be sent to the applicant of record
- All resubmittals must be sent to [PERMITS@NYCSCA.ORG](mailto:PERMITS@NYCSCA.ORG)

# 10. Withdrawal: Filing & PAA

- It is not permitted to withdraw work type individually in DOB NOW. It must withdraw filing. E.g., S1 has GC and MS work types; it is not permitted to withdraw MS individually. In order to withdraw MS, S1 filing must be withdrawal entirely.
- It is permitted to withdraw applicant or lab in DOB NOW without the form when the application is filed after 7/1/2019.

Login to DOB NOW to submit Jobs, Filings & Applications

Enter your eFiling or DOB NOW Licensing account information

Email:

Password:

I'm not a robot

**1**

[Need more help? Contact us.](#)

Let us know how we can help you by filling out the form below: General inquiries will receive a response within approximately 3 business days. Requests for supersedes and withdrawals may take up to 3 weeks to be processed.

Help us help you by selecting the appropriate Module (the tool you have a question about). Items marked with \* are required.

Module\*

Question Category\*

Job/Filing Reference Number Type

Reference Number

License Number, if applicable

What is your role for this filing?

Explain Question\* (Maximum limit: 500 Characters)

Supporting Information Upload

Your Name:

Your Phone:

Email Address\*

I'm not a robot

**2**

[Additional Information](#)      [Superseding Letter](#)      [Withdrawal Request](#)

**DOB NOW BUILD**      **NYC Buildings**

## Withdrawal Letter

Effective March 6, 2023, withdrawal requests for DOB NOW: *Build* filings are submitted within DOB NOW and do not require completion of this letter except:

- Requests to withdraw a filing (not a stakeholder)
- Withdraw the concrete testing lab on the TR2
- Withdrawal requests for DOB NOW filings created prior to July 1, 2019 in pre-filing status but payment has been submitted
- supersede requests for Electrical, Elevator, Place of Assembly, Temporary Place of Assembly filings.

Refer to the [Supersede and Withdrawal Guide](#) for instructions. Only if applicable, upload this completed letter to [www.nyc.gov/build](#)

Date:

DOB NOW: *Build* Job Filing Number(s):   
(ex. M00123456-11)

Property Address including Borough:

Check One:

**Withdrawal of filing (if legalization is selected as the Filing Type, the filing cannot be withdrawn)**

~~Withdrawal of:  (role of stakeholder being withdrawn)~~  
(ex. PW1 Applicant, Concrete Testing Lab, Owner, etc.)

Owner:	Stakeholder (being withdrawn):
By signing below, you are acknowledging you are the current owner of the property.	Name: <input type="text"/>
Name: <input type="text"/>	Email: <input type="text"/>
Signature: <input type="text"/>	License/Registration No.: <input type="text"/>
Notary Seal or Signature (if no professional seal at right): <input type="text"/>	Signature: <input type="text"/>
	Professional Seal (if applicable): <input type="text"/>

**Owner must sign**

Submission of this letter does not constitute acceptance by the Department of Buildings until DOB NOW reflects the requested change.



# 10. Withdrawal: Filing & PAA

When a permit has been issued to a project:

- The PO must call for an inspection. The inspector will open an **Inspection Report** and verify that no work was done.
- **The open Inspection Report** must be closed by the inspector to confirm no work was performed.
- BIS application: Withdrawal is still done with a PW1 with owner and applicant's signature. Email to Planreview mailbox.

Refer to [DOB Supersede & Withdrawal Guide](#) for more details



### Supersede and Withdrawal Guide

Updated November 2023

Supersede of:	Method	Requestor	Filing Status (Pending Request)	Permit Status (Pending Request)	Filing Status (Request Approved)	Permit Status (Request Approved)	Fee	DOB Review
Applicant (PW1)	DOB NOW: <b>Build – Job Filings</b> dashboard, select 'Supersede' under Filing Action ★	Superseding Applicant and Owner (applicant submits)	<b>On Hold – Pending Supersede of Applicant of Record</b>	<b>On Hold – Pending Supersede of Applicant of Record</b>	Prior status restored	Prior status restored	\$130★	Yes★
Contractor/Licensee (PW2)	DOB NOW: <b>Build – Work Permits</b> dashboard, select 'Renew Work Permit' under Filing Action then choose 'Renew Permit with changes'	Contractor/Licensee	No change	<b>Permit Issued</b> upon QA review	No change	<b>Permit Issued</b>	\$130	QA Review
Electrical Contractor/Electrical Permit	New electrical contractor pulls a new permit for the work and includes permit number of superseding application in job description.	Electrical Contractor	No change	No change	Permit Issued	Permit Issued	\$40	No

# 11. Supersede

- Submit supersede request in DOB NOW: Build
- Supersede request is a **2-step** process:
  - **Step 1** – Supersede Request for Approved Jobs:
    - AI1: In lieu of plans, applicants must submit AI1 with a statement:  
*Submitted herewith for Approval is (Name#1); to supersede (Name#2) as the applicant of record for the (DOB job#). I (Name#1) takes responsibility for this filing as per AC 28-104.2.1.5 and ensure compliance with the NYC Construction Codes and applicable laws and rules. No drawings being submitted at this time.*  
*Option 1: No amended plans to be submitted* ←  

Or

*Option 2: Revise drawings will be submitted as a post approval amendment.*  
→  
When submitted, applicant must delete the option that does not apply.
  - When supersede request is approved, follow step 2 below.

# 11. Supersede

- Supersede (cont'd)
  - **Step 1** – Supersede Request for Permitted Jobs:
    - Applicants must submit AI1 for all supersede requests and follow the screenshot:

The screenshot shows a form titled "Documents/ Waiver" with the following questions and options:

Question	Yes	No
Are you submitting updated plans?	<input type="radio"/>	<input checked="" type="radio"/>
Are you submitted an AI1 form (minor plan or other non-plan changes)?	<input checked="" type="radio"/>	<input type="radio"/>
None of the above - Request waiver to keep existing plans and documents	<input type="radio"/>	<input checked="" type="radio"/>

- See statement above for AI1 statements.
- When supersede request is approved, follow step 2 below.

# 11. Supersede

- Supersede (cont'd)
  - **Step 2** – PAA is required if amended plans are to be submitted (applicable for approved and permitted jobs)
    - If amended plans to be submitted, applicant must file PAA

# 12. CCD1 Request

- Two ways to submit CCD1 request:
  - CCD1 can be entered directly into BCC 2.0 by the applicant if they have access
  - Submit **ONE flattened PDF** to [CCD1@nycsca.org](mailto:CCD1@nycsca.org)
- Do **NOT** use DOB NOW to submit SCA CCD1 request unless it is directed by the SCA
- Any attachments (drawings or other documents) must be formatted on 11" x 17" paper or smaller
- CCD1 form

# 12. CCD1 Request

## Required Submissions:

- Explain the reason for CCD1 - State in detail the **practical difficulty** that is
  - Describe proposed work and locations causing the issue
  - Provide details and circumstances of the request
  - Give full description of request with code sections
- Provide the analysis as to **equally safe alternative**
  - Stipulations and special additional measures to be taken
  - Demonstrate equivalence to the code requirements
- Drawings plans sections details signed and sealed with dimensions and notes to explain (if needed)
- If existing condition or completed work explain that no problem have been seen
- Photos of the location when available
- Special inspection sign off TR1 when applicable
- Submit any supporting documents, e.g. sign offs, agency approvals, inspection reports

# 13. Zoning & Egress Review Request

1. Applicant to submit BCC Transmittal, zoning and egress plan set to **PLANREVIEW@nycsca.org**
2. **BCC#** and **Examiner** will be assigned
3. **OneDrive folder** will be created
4. Examiner to **raise objections** in BCC system
5. Examiner to **record status** in BCC system. Auto email will be sent to the applicant of record.
6. When a job in “Z/E disapproved” status without DOB NOW job#, applicant to upload zoning and egress plan set to OneDrive and email **PLANREVIEW@nycsca.org**

Job No: 0582- -24  
Job Status: Filed Project  
Zoning/Egress Status: Zoning/Egress In Review







### Plan Approval

SCHOOL INFO	JOB INFO	DISTRIBUTION
School ID: K382 EARLY DEMOLITION Building ID: K382 Borough: Brooklyn Address: <a href="#">425 Ovington Avenue</a> Block/Lot/Bin: <a href="#">5873/77/3328827</a>	Job No: 0582- -24 DOB No: <b>B00000000</b> App. Type: DOB NOW - New Buildings Category Description: NEW BUILDING Design: N/A Package: N/A SHPO: <input type="checkbox"/> Flood Hazard: <input type="checkbox"/> Open Objections: 13 of 13 LLW: <a href="#">115945</a> Const. Inspector: N/A Review: Full Review Description: Zonina Analysis.	Lead Applicant: <a href="#">Mueller, John</a> Plan Examiner: <b><a href="#">Brink, Christopher</a></b> Close-out Inspector: Project Officer: <a href="#">GEORGE WAKIM</a> PO Ext.: 5416
Bid Review: <input type="text" value="No"/>	Full Self-Certification: <input type="text" value="No"/>	Objection Self-Certification: <input type="text" value="No"/>
Full Review: <input type="text" value="Yes"/>		

Seq. No.	Received	Assigned	Review...	Status	Comment	Filing Type	Examiner	Status ...
Job Filing: B00000000-11 GC - GENERAL CONSTRUCTION								
1	08/22/2024	08/22/2024		Zoning/Egress In Review		Initial Filing	<a href="#">Christopher...</a>	Carmen Mateo

# 14. Certificate of Compliance (COC)

NYC Buildings							
CERTIFICATE OF COMPLIANCE							
Address: 339 MORRIS AVENUE, BRONX						Issued On: 08/22/2023	
BIN:2000957	Item	Location	Efficiency	Manufacturer Name	Capacity	Job Filing Number	Number of Items
Ventilation Systems	RF-09	ROOF	1 SEER	Cook	2585 CFM	X00386292-I1	1
	Item Description		EXHAUST FAN				
	Model Name and Number		225ACE 225C5B				
	Serial Number		325SI90279-00/0011801				

One item per row

## How many devices can be added on a MS filing?

A max. of (50) devices can be filed/ added to the same job filing. Additional devices can be added on a subsequent filing.

# 14. Certificate of Compliance (COC)

- Equipment Specification Table must be completed

**M00030896-11**

Plans/Work (PW1)

Zoning Information

Scope of Work

Cost Affidavit (PW3)

Technical Report

Technical Report (TR1)

Documents

Work Permit (PW2)

Statements & Signatures

## Mechanical Scope of Work

### Equipment Specification Table

+ Add

### Equipment Specification Table

Sub-category	Heating and Air Conc	Item Name	AIR HANDLING UN...	Item Description	AHU-1
Location	ROOF	Number of Items	1	Capacity Number	11000
Capacity Units	CFM	Equipment Efficiency	15.9	Equipment Units	EER
Manufacturer Name	ANNEXAIR	Is a Certificate of Compliance (Equipment Use Permit) Needed?	Yes		
Model Name and Number	ERP-E-09-EW05-HE-D-HR-ASTP				
Serial Number	---				

# 14. Certificate of Compliance (COC)

- The school has around (400) mechanical units that will require COCs. DOB NOW only allows for (50) units per filing. I can submit additional 7 filings for the mechanical equipment, but how should the total SUM BTUs input to DOB NOW? Should I only include the BTU units for the equipment on each filing or should the all the info for the entire Mechanical scope be on the I1 filing?

All the info for the mechanical should be on the I1 filing, so the requirement for commissioning can be determined.

- **Should the same set of dwgs be uploaded for all I1 and S1-S7 filings?**

No. One set of dwgs uploaded for I1 is acceptable. A11 to clarify the purpose of S1-S7 is sufficient. No duplicated set is required to be uploaded for S1-S7 filings.

- **Is PAA required to update COC (e.g. serial #)?**

No. COC can be updated without a PAA.

The equipment spec table can be modified up **until TR Final certification is completed** – this includes adding new items. The equipment spec table can be modified by **all Stakeholders.**

Before the job is ready for signoff, COC must match with the approved plans. Applicant must submit PAA for I1 to match the drawings with the final COC.

# 15. Boiler Equipment (BE)

- Boiler Equipment (BE) Work Type consists of three components: Boiler (BL), Fuel Burner (FB), and Fuel Storage (FS).

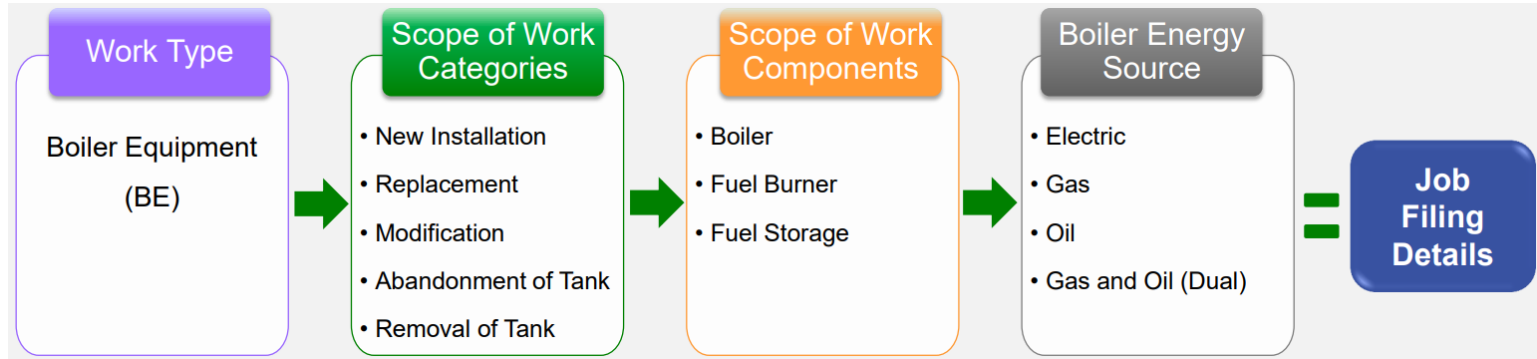

- How many devices can be added on a Boiler Equipment filing?**

A maximum of 10 devices can be filed/added to the same Job Filing. Ten new Boilers can be installed, along with 10 new associated Fuel Burners and 10 new associated Fuel Storage tanks. All Boiler devices on the same Job Filing must have the same Proposed Information.



## **Can I add additional boiler equipment to an approved filing with a PAA?**

No, once the filing is submitted, additional boiler equipment cannot be added.

- If the job is in disapproved/ plan review status, withdraw and refile.
- If the job is in approved/ permit status, file subsequent filing.

# 16. Schedule of Occupancy

- Formerly Schedule A
- Existing **BIS** NB/Alt1 jobs that need a CO must obtain COs via DOB NOW
- Prior to CO request, **BIS** jobs must file a Schedule of Occupancy Filing in DOB NOW reviewed by **DOB** Plan Examiners
- Keep the record as **generic** as possible in order to avoid filing an Alt-CO applications for minor changes in occupancy. E.g., list “mechanical/ electrical rooms” for telecommunication rooms, boiler rooms, electrical closets, HW rooms, gas meter room, etc.; list “classrooms” for laboratoires, dance studio, exercise room, etc.
- Refer to DR 1.3.2.1 for Occupancy Classifications

Occupancy Classification	Occupancy Group	Description Of Use	Live Load(lb s/sq.ft.)	Max Person Permitted	Zoning Use Group	Dwelling or Rooming Units	Occupancy Type
Floor: Floor Number(s) - 1							
Existing							
Proposed	Educational	E	Academies and schools	OG	120	III(B)	Not Applicable
Description Of Use Comments		Existing: Proposed: <b>CLASSROOMS</b> MUSIC CLASSROOMS, LABORATORIES, DANCE STUDIO					
Floor: Floor Number(s) - 1							
Existing							
Proposed	Educational	E	Academies and schools	OG	120	III(B)	Not Applicable
Description Of Use Comments		Existing: Proposed: <b>MECHANICAL/ ELECTRICAL ROOMS</b> TELECOMMUNICATION ROOMS, BOILER ROOMS, ELECTRICAL CLOSETS, HW ROOMS, EMERGENCY GENERATOR ROOM <b>STORAGE ROOMS</b> REFUSE/RECYCLING ROOM					

# 17. Place of Assembly: Sign

- For a cafeteria, PA sign occupant total is only for dining area. Do **NOT** include servery and kitchen.
- For an Auditorium, PA sign should list max occupants for the seating area and the platform/ stage area.\*

Note: Occupant load analysis on plans is for egress calculation, not for PA sign.

- Name of establishment on PACO should **NOT** include school name, only space name. E.g., cafeteria is acceptable; PS196 cafeteria is unacceptable.

Number	Name	Occupancy	Area	Gross vs. Net	Area per Occupant	Occupant Load
C01	Student Dining	A-3	10005 SF	Net	15	667
C03	Boy's Toilet					
C04	Girl's Toilet					
C05	Kitchen	F-2	1923 SF	Gross	200	10
C05G	Servery	A-3	943 SF	Gross	200	5

**NYC Buildings**

**PLACE OF ASSEMBLY**  
CERTIFICATE OF OPERATION

Certificate Number: \_\_\_\_\_ Borough: \_\_\_\_\_  
 Premises Address: \_\_\_\_\_ Block/Lot: \_\_\_\_\_  
 Issued On: 08/14/2020 BIN: \_\_\_\_\_  
 Related NB/A1 Job No: \_\_\_\_\_

Name of Establishment: **CAFETERIA**

Floors: 001  
 Occupancy Classification and Description: A-3 **CAFETERIA** Number of Persons: 667

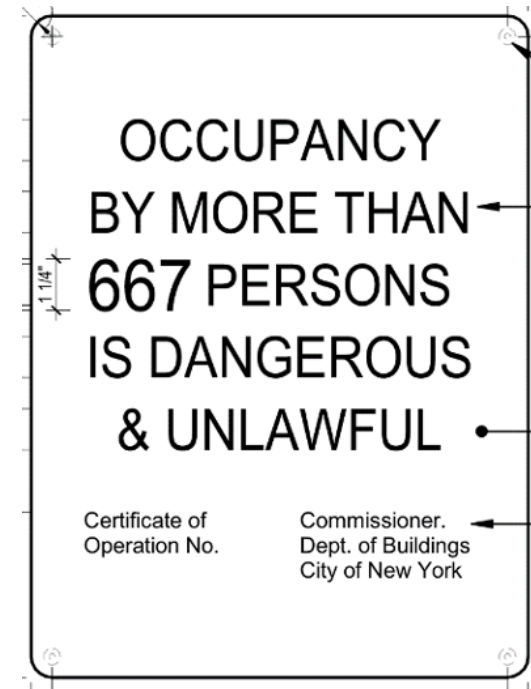

# 17. Place of Assembly: Schedule of Occupancy

- Each PA room on every floor must be listed **separately** on Schedule of Occupancy. E.g., cafeteria and auditorium are on 1<sup>st</sup> floor. One row (A-3) for cafeteria; one row (A-3) for auditorium.
- When Schedule of Occupancy is amended, PA's name of establishment and occupancy load on PA filing to match with Schedule of Occupancy and plans.

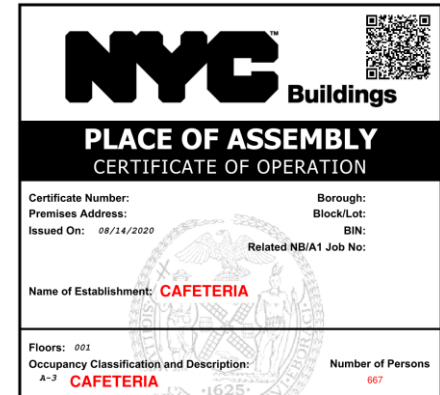

## Cafeteria

2022 BC

(BC 508.1 exception 5)

- Dining and Servery are listed under A-3 = (672) occ. load
- Kitchen is listed under F-2 = (10) occ. load

Number	Name	Occupancy	Area	Gross vs. Net	Area per Occupant	Occupant Load
C01	Student Dining	A-3	10005 SF	Net	15	667
C03	Boy's Toilet					
C04	Girl's Toilet					
C05	Kitchen	F-2	1923 SF	Gross	200	10
C05G	Servery	A-3	943 SF	Gross	200	5

Occupancy Classification	Occupancy Group	Description Of Use	Live Load(lb/s/sq.ft.)	Max Person Permitted	Zoning Use Group	Dwelling or Rooming Units	Occupancy Type
Floor: Floor Number(s) - 1							
Existing							
Proposed	Assembly	A-3	Cafeteria -school up to grade 12 EDU	OG	672	III(B)	Not Applicable
Description Of Use Comments		Existing: STUDENT DINING 667, SERVERY Proposed: STUDENT DINING 667, SERVERY					
Floor: Floor Number(s) - 1							
Existing							
Proposed	Factory and Industrial	F-2	Commercial Kitchen Adjoining Dining Facility	OG	10	III(B)	Not Applicable
Description Of Use Comments		Existing: KITCHEN Proposed: KITCHEN					

# 17. Place of Assembly: Schedule of Occupancy

## Multipurpose Room

- When one space that is used as both an auditorium (A-3) and a gymnasium with seating (A-4), create a single floor/use record and select the Occupancy Group of **the most intensive use (highest hazard/most people)**. In the Description of Use comments enter text about all uses.
- Do **NOT** use Gymatoriums and Cafetoriums because the terms are used in the SCA Program of Requirements but are not recognized in the DOB system/ Building Code. List “**Multipurpose Room**” on Name of Establishment on PA application.
- Provide **all proposed primary/ alternate layouts** on PA application - Typically furniture and aisle layout must be shown
- To match / clarify the occupant load shown on PA application, Schedule of Occupancy should include **detailed descriptions**
- DOB NOW: PA application – Alternate plans can be added up to 25

# 17. Place of Assembly: Schedule of Occupancy

## Multipurpose Room

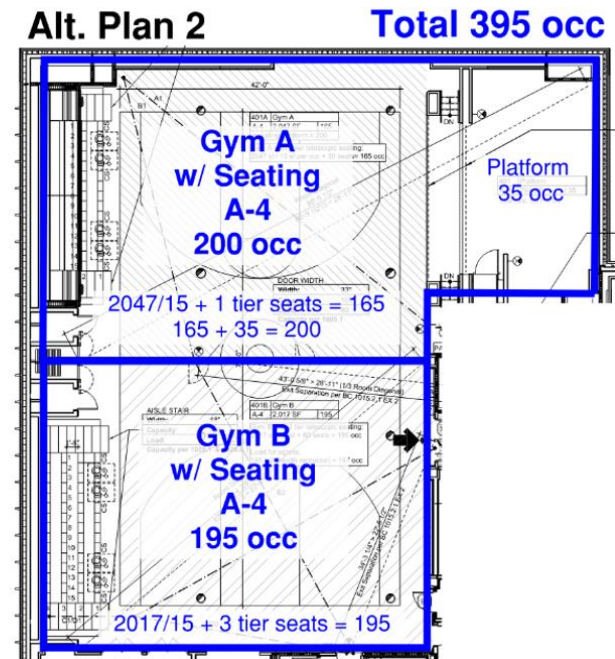
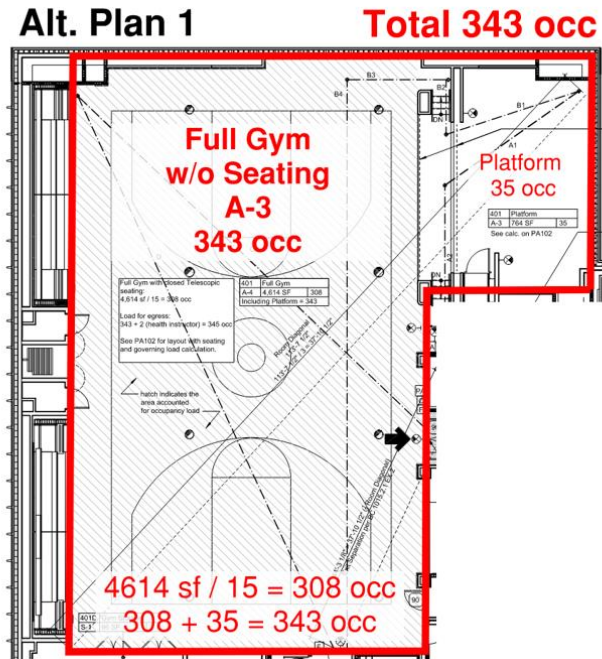
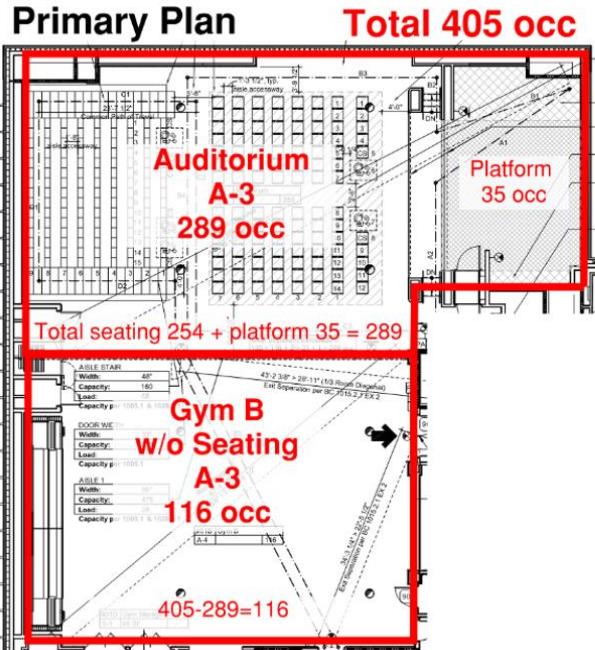

Occupancy Classification	Occupancy Group	Description Of Use	Live Load (lb/s/sq. ft.)	Max Person Permitted	Zoning Use Group	Dwelling or Rooming Units	Occupancy Type
Floor: Floor Number(s) - 1							
<b>Existing</b>							
<b>Proposed</b>	Assembly	A-3	School Auditorium - EDU	OG	405	III(B)	Not Applicable
<b>Description Of Use Comments</b>		<b>Existing:</b> <b>Proposed:</b> A-3 AUDITORIUM (289= 254 + PLATFORM) + A-3 GYM B W/O SEATING (116) = 405; A-3 GYM W/O SEATING (308 + PLATFORM) = 343; A-4 GYM A W/ SEATING (200=165 + PLATFORM) + A-4 GYM B W/ SEATING (195) = 395					

# 17. Place of Assembly: PACO

## Multipurpose Room

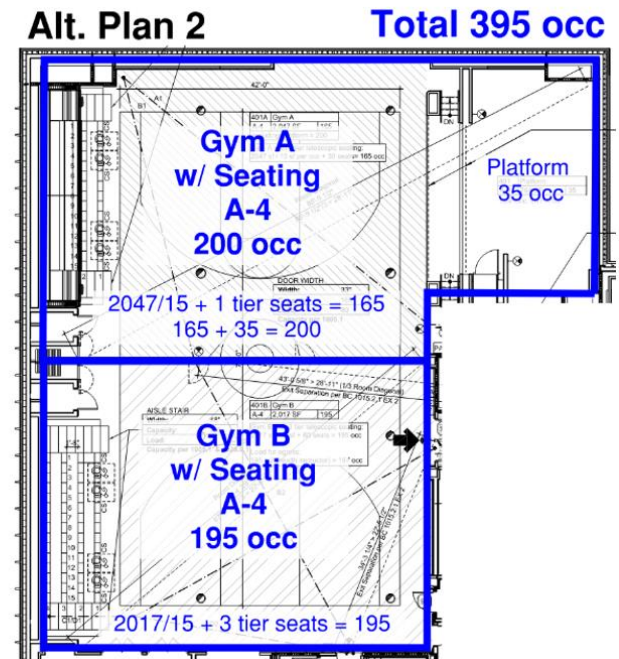
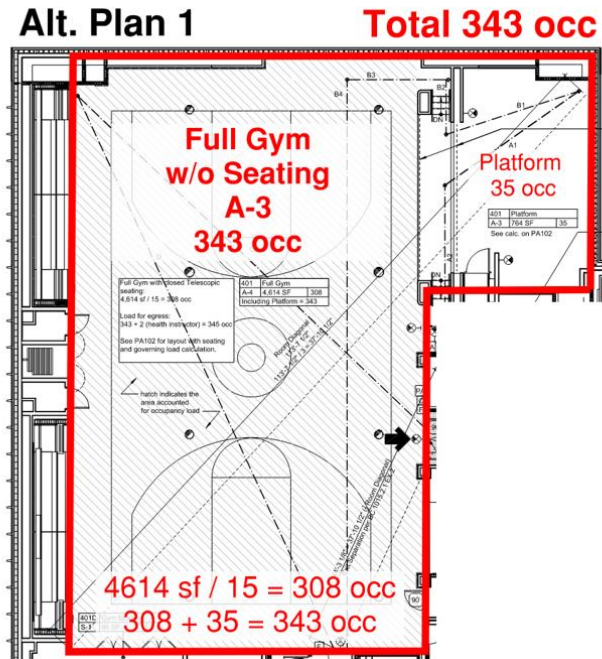
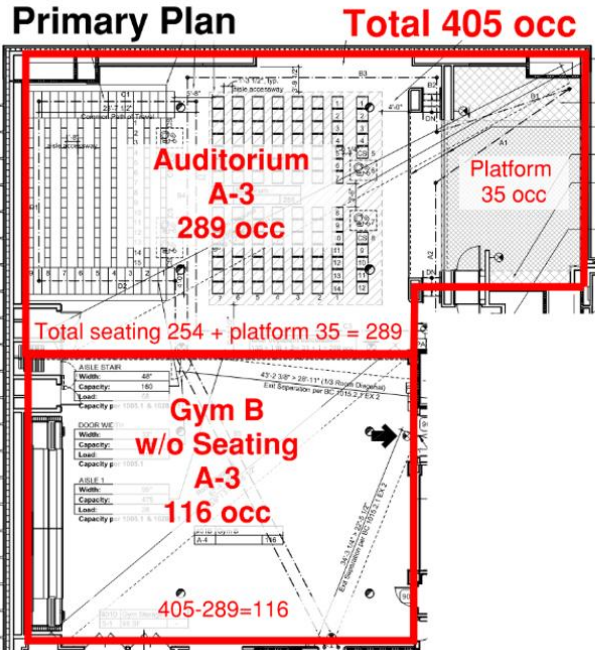

Plan Type	Occupancy Designation	Description	Code	Number of Persons	Cabaret
Primary Plan	Other	A3Auditorium+A3GymB w/o Seat		405	No
Alternate Plan 1	Other	A3 Gym w/o Seat		343	No
Alternate Plan 2	Other	A4GymA w Seat+A4GymB w Seat		395	No

When using "Other" for Occupancy Designation, the description line can only accept 30 characters max.

# 18. FDNY filings – FA/ FPP/ FS

- As per Local Law 195 of 2018, effective June 2, 2019, all Fire Alarm (FA), Fire Suppression (FS), and Fire Protection Plan (FPP) must be filed and approved by **FDNY**.
- Applicant must submit the approved documents to BCC for **record only**.
  - Applicant must obtain FDNY approval first
  - Once FDNY is approved, submit FDNY Approved Documents / Drawing to BCC by email [planreview@nycsca.org](mailto:planreview@nycsca.org)
- More details on BCC Website:
  - [Fire Alarm Guide](#)
  - [Fire Suppression Guide](#)
  - [Fire Protection Plan Guide](#)

# 19. Non-file/ Permit Exempt Projects

- Some work may be exempt from permit per AC 28-105.4 and 1RCNY 101-14 but CID inspection is still required.

**1** Doing Business

**2** Environment Regulatory Compliance

**3** Building Code Compliance

**4** Guides and Procedures

**5** Permit Exempt (Non-filed) Project Guide Video

Getting Started

Contracting with Us

Prequalification Process

Business Development

Subcontractor

Adding/Updating Vendor Information

Safety Manual & Checklists

PLA & Labor Law Compliance

Insurance

Construction Process

Environment Regulatory Compliance

Furniture and Equipment

Getting Paid

Legal

Office of Inspector General

SCA COVID-19 Info Portal

FAQs

Building Code Compliance

Construction Inspection

& Environmental Hygiene

Safety

Building Code Compliance Plan Review and Permitting

Business Development

Subcontractor

Adding/Updating Vendor Information

Safety Manual & Checklists

PLA & Labor Law Compliance

Insurance

Construction Process

Environment Regulatory Compliance

The New York City School Construction Authority's Building Code Compliance Division (formerly referred to as the Facilities Inspection Division or FID) carries out the mission of the New York City Department of Buildings (DOB) in accordance with a Memorandum of Understanding between DOB and SCA. Through its experienced professional staff of plan examiners, permit processors, and inspectors, BCC helps to facilitate:

- Plan review and permitting, which are done at SCA headquarters, not a DOB borough office, and are fee exempt.
- Resolving violations, which are a prerequisite to completion of close-out and transfer.
- Conducting final inspections and obtaining Certificates of Occupancy.

The following resources provide in detail how the SCA facilitates DOB plan reviews, permitting, and sign-offs.

Guides and Procedures

- Construction Inspection Guide\*

- Fire Alarm Guide
- Fire Protection Plan Guide
- Permits Guide
- Public Assembly Guide
- Fire Suppression System Guide
- Permit Exempt (Non-filed) Project Guide Video
- Plan Exam Objection Response Video
- Support of Excavation Sheeting & Shoring Guide
- Temporary Fuel Storage Guide
- Concrete Procedures
- Resolving Violations Procedures
- (EQ) Fence Shed Scaffold Chute Guide

## 20. BCC Mailbox

Send your request to	Request
<a href="mailto:planreview@nycsca.org">planreview@nycsca.org</a>	BIS filings & PAA BPP filings Zoning & Egress Review Request FDNY filings – FA, FS, FPP Alt I – No Work filing OneDrive folder Access BCC 2.0 System Access Citrix access Permit Exempt Submission Questions General Questions
<a href="mailto:permits@nycsca.org">permits@nycsca.org</a>	Permit Requests for BIS and DOB NOW Application Processing Unit email Questions regarding DOB NOW
<a href="mailto:foldersdrawings@nycsca.org">foldersdrawings@nycsca.org</a>	Request Approval/ Accepted plans, forms and documentations

# 21. FAQs

**Q.1. The scope includes underground pre-cast concrete structures and currently is filed under GC work type. DOB NOW system does not allow me to add TR2 and TR3. What to do?**

TR2 or TR3 can only be added under EA, ST, FO, or SOE work type. File a subsequent filing to add TR2/TR3 requirements.

For site civil work, recommend to have GC+EA work type when TR2/ TR3 is required.

**Note:** Same concept applies to exterior ramp: There is footing and foundation proposed for exterior ramp. Recommend to file GC+FO work type in order to add proper Special Inspections and Progress Inspections.

Refer to [https://www.nyc.gov/assets/buildings/pdf/dob\\_now\\_technical\\_reports.pdf](https://www.nyc.gov/assets/buildings/pdf/dob_now_technical_reports.pdf)

**DOB  
NOW** **Technical Reports**  
*Updated August 2024*

Special Inspections	Code Section	Work Type(s)
Concrete Design Mix ( <b>TR3</b> )	BC 1911.5 (2014), BC 1905.3 (2022)	EA*, ST*, FO*, SOE*
Concrete Sampling and Testing ( <b>TR2</b> )	BC 1911.10 (2014), BC 1905.6 (2022)	EA*, ST*, FO*, SOE*

# 21. FAQs



## Q.2. How to request reinstatement?

BCC does not require reinstatement once approval is obtained

## Q.3. When can I create subsequent filings?

A subsequent filing can be created in DOB NOW: Build when an initial filing is in pre-filing status as well as permit status.

## Q.4. How do I know the scope of work needs a permit or not?

Refer to 1RCNY 101-14: Categories of work that may or may not require a permit

[https://www.nyc.gov/assets/buildings/rules/1\\_RCNY\\_101-14.pdf](https://www.nyc.gov/assets/buildings/rules/1_RCNY_101-14.pdf)

## Q.5. Can I waive the TR2 and TR3?

On the Concrete Scope of Work section, the following question must first be answered as Yes.

Is the proposed total concrete placement less than 50 cubic yards? Yes

Then, to waive the TR2 and TR3, answer the following question as Yes:

Are you proportioning your concrete without field experience or trial mixtures? Yes

The below selections will waive the TR2 only:

Are you proportioning your concrete without field experience or trial mixtures? No

Would you like to waive the requirement for testing of fresh concrete sampling (TR2)? Yes

There is no option to waive only the TR3.

# 21. FAQs

## Q.6. How to file generator work?

Oil-fired generator: MS for the generator(s); BE for the fuel storage; EL for the electrical

Gas-fired generator: MS for the generator(s); PL for the gas; EL for the electrical

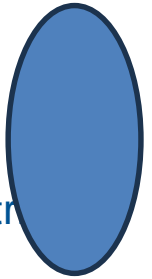

# 22.1. DOB Resources – Login to DOB NOW

**!** On June 3, 2024, DOB NOW integrated with NYC.ID, requiring all returning and new users to **have an NYC.ID account to login to DOB NOW.**

- See DOB Step-By-Step guides for more details

<https://www.nyc.gov/site/buildings/industry/dob-now-registration-tips.page>

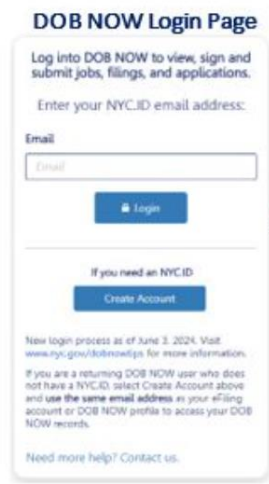

automatically redirects →



← automatically redirects

# 22.2. DOB Resources

## Special & Progress Inspections vs. Work Types

[https://www.nyc.gov/assets/buildings/pdf/dob\\_now\\_technical\\_reports.pdf](https://www.nyc.gov/assets/buildings/pdf/dob_now_technical_reports.pdf)



Technical Reports – Updated August 2024

### Technical Reports

*Updated August 2024*

Special Inspections	Code Section	Work Type(s)
Subgrade Inspection	BC 1704.7.1 (2014), BC 1705.6 (2022)	AN, SG, ST, FO, EA, SOE, PMM
Subsurface Conditions – Fill Placement & In-Place Density	BC 1704.7.2 (2014), BC1704.7.3 (2014), BC 1705.6 (2022)	AN, SG, ST, FO, EA, SOE, PMM
Subsurface Investigations (Borings/Test Pits) <b>(TR4)</b>	BC 1704.7.4 (2014), BC 1705.6 (2022)	PL, SG, GC, FO, EA, SOE, PMM

# 22.3. DOB Resources

## Waiver and Deferral Document Request List

[https://www.nyc.gov/assets/buildings/pdf/dob\\_now\\_build\\_waiver\\_and\\_deferral\\_doc\\_request\\_list.pdf](https://www.nyc.gov/assets/buildings/pdf/dob_now_build_waiver_and_deferral_doc_request_list.pdf)

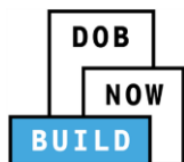

### WAIVER AND DEFERRAL DOCUMENT REQUEST LIST – Updated August 26, 2024

Document Name	Applicable Work Type(s)	Prior to Stage	Waiver	Deferral
DEP ACP-5: Asbestos Assessment Report	PL, SP, SD, AN, CC, SH, SF, FN, SG, MS, ST, GC, FO, EA, SE, PMM, FD, GR, SL	Approval	Yes	Yes
DEP Certification of Insurance	GC, FO, EA	Permit Issuance	No	No
DEP Stormwater Construction Permit	GC, FO, EA, SE, FD	Approval	No	No

# 22.4. DOB Resources

## DOB NOW: Build - Filings Resources

<https://www.nyc.gov/site/buildings/industry/dob-now-build.page>

The screenshot shows the NYC Department of Buildings website navigation. The 'Industry' tab is active. A red arrow points from the 'Using DOB NOW' link in the left sidebar to a red-bordered box containing the following list:

- Alteration filings (GC, FO, EA, SE and PMM) ([FAQ](#) and [Resources](#))
- Mechanical Systems filings ([FAQ](#) and [Resources](#))
- New Buildings, Alteration-CO and Occupancy for BIS Jobs filings ([FAQ](#) and [Resources](#))
- Place of Assembly and Temporary Place of Assembly filings ([FAQ](#) and [Resources](#))
- Plumbing, Sprinkler and Standpipe filings ([FAQ](#) and [Resources](#))
- Sidewalk Shed, Supported Scaffold, Fence and Sign filings ([FAQ](#) and [Resources](#))

# 22.5. DOB Resources

## DOB NOW Trainings

<https://www.nyc.gov/site/buildings/industry/dob-now-training.page>

Permits & Plan Exam

After Hour Variances

Obtain CO

Required Items

## DOB NOW Training

### Recent Trainings

Training Type	Topics	Materials
Design Professionals & Filing Representatives	<ul style="list-style-type: none"> <li>• General Construction (GC)</li> <li>• Foundation (FO)</li> <li>• Earthwork (EA)</li> <li>• Support of Excavation (SE)</li> <li>• Protection &amp; Mechanical Methods (PMM)</li> </ul> <p>New features (improved search, exporting jobs, etc.)</p>	<p><a href="#">DOB NOW: Build Design Professional Training Presentation</a></p> <p>View a previous version of this training: <a href="#">DOB NOW: Build Design Professional Training Webinar</a></p>



# 22.6. DOB Resources

## DOB NOW: Build Frequently Asked Questions

<https://www.nyc.gov/site/buildings/industry/dob-now-build-faqs.page>



NYC Buildings

Español ▶ Translate ▼ Text-Size

Home DOB Tenant Property or Business Owner **Industry** Safety Codes Search

Design Professionals Construction Professionals Licensing building UP

Permits & Plan Exam

After Hour Variances

## DOB NOW: *Build* Frequently Asked Questions

### General Construction

- What kind of work is included in the General Construction (GC) work type? +
- What work types can be combine filed with a General Construction application? +
- How do I add Plumbing to a General Construction (GC) filing? +
- How do I select a final inspection by a registered design professional? +

