



Safety Program & Procedures Manual

2009

© NYCSCA 2009
Environmental and Regulatory Compliance (ERC)
Safety Unit
Long Island City, New York 11101
Phone (718) 472-8466
Fax (718) 472-8460
Email: SafetyDirector@nycsca.org

Table of Contents

<i>Preface</i>	15
Introduction	15
Objectives of the Program	15
The Mission of the NYCSCA Safety Unit	15
Using this Book	16
<i>Part 1: Introduction</i>	19
Responsibilities	19
Subcontractor's Responsibilities	25
Public Safety	27
Safety Meetings	29
Enforcement	31
Worker's Safety Education, Training and Promotion	32
Reporting Of Accident/incident Or Damage	35
Claim Procedure	36
Jobsite Incident/Accident Report Format	38
<i>Part 1 Form: Job Site Incident/Accident Form</i>	41
<i>Part 1 Form: C2- New York State Employer's Report of Work-Related Accident/Occupational Disease</i>	45
<i>Part 1 Form: Contractor Designated Competent Site Supervisor</i>	47
<i>Part 1 Form: Subcontractor Competent Foreman</i>	57
<i>Part 1 Checklist: Preconstruction Safety</i>	61
<i>Part 1 Checklist: Safety Unit Pocket Guide</i>	67
<i>Part 2: General Safety & Health Provisions</i>	71
Introduction	71
SCA General Requirements	71
Special Projects	72
Safety Training and Education	73
First Aid and Medical Attention	73
Fire Protection and Prevention	74
Housekeeping	74
Illumination	74
Sanitation	74

Vermin control _____	76
Change rooms _____	76
Personal Protective Equipment _____	76
Means of Egress _____	76
Employee Emergency Evacuation Plans _____	76
Noise Mitigation _____	71
<i>Part 2 Form: Receipt of Safety Manual for Special Projects</i> _____	79
<i>Part 3: Concrete & Masonry Construction</i> _____	83
Introduction _____	83
SCA General Requirements _____	83
Lockout and Tagout Procedures _____	85
Requirements for Cast in Place Concrete _____	85
Reinforcing Steel _____	86
Removal of Formwork _____	87
Requirements for Pre-cast Concrete _____	87
Requirements for Masonry Construction _____	87
<i>Part 4: Confined Space Entry</i> _____	89
Introduction _____	89
Basic Terminology _____	89
SCA General Requirements _____	89
Purpose _____	89
Responsibility _____	89
Requirements _____	90
Isolation _____	92
Purging, Inerting, Flushing, or Ventilating _____	92
Testing _____	92
Permit System _____	93
Training _____	93
Duties _____	94
Rescue and Emergency Services _____	95
Post Entry Review _____	96
Program Review _____	96
<i>Part 4 Form: Confined Space Entry Procedure Worksheet</i> _____	97
<i>Part 4 Appendix A: Permit-Required Confined Space Decision Flow Chart</i> _____	105

Part 5: Cranes, Derricks, Elevators & Hoists	107
Cranes and Derricks	107
SCA General Requirements	107
Material Hoists, Personnel Hoists, and Elevators	112
Part 5 Checklist: Pre-Lift Setup Checklist	123
Part 5 Form: Notification of Crane (NOC)	127
Part 5 Form: Sample Crane Inspection	131
Part 6: Demolition	141
Introduction	141
SCA General Requirements	141
Preparatory Operations	141
Stairs, Passageways and Ladders	142
Chutes	143
Removal of Debris through Floor Openings	143
Removal of Walls, Masonry Section and Chimneys	143
Manual Removal of Floors	144
Removal of Walls, Floor and Material with Equipment	144
Storage	145
Removal of Steel Construction	145
Part 7: Electrical	147
Introduction	147
SCA General Requirements	147
Basic Terminology	148
Approval	148
Examination, installation, and use of equipment	148
Guarding of live parts	148
General requirements for temporary wiring	149
Cabinets, boxes, and fittings	150
Fixture wires – General	150
Equipment for general use	150
Interrupting and isolating devices	151
Mobile and portable equipment	151
Protection of Employees	152
Passageways and open spaces	152

Load ratings	152
Fuses	152
Cords and cables	153
Controls	153
Equipment and circuits	153
Tags	153
Deteriorating agents	153
Protection against corrosion	153
Part 8: Excavations	155
Introduction	155
Basic Terminology	155
General Requirements	155
Surface encumbrances	157
Underground installations	157
Access and egress	157
Exposure to vehicular traffic	158
Exposure to falling loads	158
Warning system for mobile equipment	158
Hazardous atmospheres	158
Stability of adjacent structures	159
Protection of employees from loose rock or soil	159
Inspections	160
Fall protection	160
Protection of Employees in Excavations	160
Design of sloping and benching systems	160
Design of support systems, shield systems, and other protective systems	161
Materials and equipment	162
Installation and removal of support	163
Shield systems	163
Part 8 Appendix A: Soil Classification	165
Scope and application	165
Basic Terminology	165
Classification of soil and rock deposits	166
Acceptable visual and manual tests	166

<i>Part 8 Appendix B: Sloping & Benching</i>	169
Scope and application	169
Basic Terminology	169
Soil classification Requirements	169
Slope Configurations	170
Excavations Made in Soil Types	172
<i>Part 8 Appendix C: Timber Shoring for Trenches</i>	177
Scope	177
Soil Classification	177
Presentation of Information	177
Basis and limitations of the data	178
Use of Tables	178
Examples to Illustrate the Use of Tables C-1.1 through C-1.3.	179
Notes for all Tables	180
<i>Part 8 Appendix D: Aluminum Hydraulic Shoring for Trenches</i>	193
Scope	193
Soil Classification	193
Presentation of Information	193
Basis and limitations of the data	194
Use of Tables	194
Example to Illustrate the Use of the Tables	195
Footnotes and general notes for Tables D-1.1, D-1.2, D-1.3, and D-1.4	195
Aluminum Hydraulic Shoring Typical Installations	197
Alternatives to Timber Shoring	206
<i>Part 8 Appendix E: Selection of Protective Systems</i>	208
Diagrams	208
<i>Part 8 Checklist: Sample Pre-Excavation</i>	213
<i>Part 8 Checklist: Trench & Excavation</i>	217
Trench & Excavation Checklist	219
<i>Part 9: Fall Protection</i>	221
Introduction	221
Basic Terminology	221
Fall Protection Systems	222
Fall Protection Systems Criteria And Practices	225

Training	231
Part 10: Fire Protection	233
Introduction	233
Basic Terminology	233
SCA General Requirements	233
Fire Protection	234
Flammable and Combustible Liquids	237
Part 10 Checklist: Temporary Heating Plan	245
Part 10 Appendix A: Enforcement of Smoking Prohibition	249
Part 10 Checklist: Hot Work Checklist	253
Part 10 Checklist: Pre-Roofing Safety Checklist	257
Part 11: Hand & Power Tools	261
Introduction	261
SCA General Requirements	261
General Requirements	261
Personal protective equipment	263
Switches	263
Hand Tools	263
Electric power-operated tools	264
Pneumatic power tools	264
Fuel powered tools	264
Hydraulic power tools	265
Powder-actuated tools	265
Abrasive Wheels and Power Tools	265
Other requirements	267
Woodworking Tools	267
Radial Saws	267
Jacks – lever and ratchet, screw, and hydraulic	268
Air Receivers	268
Part 12: Materials Handling, Storage, Use and Disposal	271
Introduction	271
Rated Capacity Tables	277
Part 13: Personal Protective Equipment	297
Introduction	297

Basic Terminology _____	297
SCA General Requirements _____	297
Personal Protective Equipment _____	297
Safety Belts, Lifelines, and Lanyards _____	301
Safety Nets _____	301
<i>Part 14: Public Protection</i> _____	303
Introduction _____	303
Sidewalk Sheds _____	303
SCA General Requirements _____	303
Diagrams _____	308
<i>Part 14 Form: Site Safety Plan Submission</i> _____	303
<i>Part 14 Form: Site Safety Plan Sign-Out Sheet</i> _____	315
<i>Part 14 Checklist: Site Safety Plan Checklist</i> _____	319
<i>Part 14 Checklist: Sidewalk Bridge Inspection</i> _____	323
<i>Part 14 Fact Sheet: New Inspection Maintenance Log Requirement</i> _____	327
<i>Part 15: Scaffolds</i> _____	331
Introduction _____	331
Basic Terminology _____	331
SCA General Requirements _____	332
Scope and application _____	335
General Requirements _____	335
Capacity _____	335
Scaffold platform construction _____	336
Criteria for supported scaffolds _____	337
Criteria for suspension scaffolds _____	338
Access _____	340
Use _____	343
Fall Protection _____	344
Falling object protection _____	347
Additional requirements applicable to specific types of scaffolds _____	348
Tube and coupler scaffolds _____	348
Fabricated frame scaffolds _____	348
Plasterers', decorators', and large area scaffolds _____	349
Bricklayers' square scaffolds _____	349

Horse scaffolds	349
Form scaffolds and carpenters' bracket scaffolds	349
Roof bracket scaffolds	349
Outrigger scaffolds	350
Pump jack scaffolds	350
Ladder jack scaffolds	351
Window jack scaffolds	351
Crawling boards	351
Step, platform, and trestle ladder scaffolds	351
adjustable suspension scaffolds	352
Catenary scaffolds	353
Float scaffolds	353
Interior hung scaffolds	353
Needle beam scaffolds	354
Multi-level suspended scaffolds	354
Mobile scaffolds	354
Repair bracket scaffolds	355
Stilts	355
Aerial lifts	356
<i>Part 15 Appendix A Drawings and Illustrations</i>	359
Introduction	359
<i>Part 15 Appendix B Licensed Master or Special Rigger Responsibilities</i>	369
Applicability	369
Basic Terminology	369
Planning	369
Supervision of Rigging Operations Other Than Critical Picks	369
Supervision of Critical Picks	370
Rigging Crew	370
Specialty Crew	370
Qualifications for Designation as a Rigging Foreman	371
Designation of a Rigging Foreman	371
Photo Identification Card	372
Responsibility	372
Failure to Comply with Rules	372

Part 15 Appendix C: Supervisory Responsibilities	373
Applicability	373
Planning	373
Supervision of Sign Hanging Operations Other Than Critical Picks	373
Supervision of Critical Picks	374
Sign Hanging Crew	374
Qualifications for Designation as a Sign Hanging Foreman	374
Designation of a Sign Hanging Foreman	375
Photo Identification Card	375
Part 15 Appendix D: Requirements Operating Suspension Scaffolds	377
Applicability	377
Minimum Requirements	377
Certificate of Fitness	378
Recognized Scaffold Safety Training Courses and Apprenticeship Programs	379
Compliance	380
Part 15 Checklist: Daily Supported Scaffold Inspection Version 1	381
Part 15 Checklist: Daily Suspended Scaffold Inspection Version 1	385
Part 15 Checklist: Daily Supported Scaffold Inspection Version 2	389
Part 15 Checklist: Daily Suspended Scaffold Inspection Version 2	393
Part 16: Signs, Signals, & Barricades	397
Introduction	397
Basic Terminology	397
SCA General Requirements	397
Accident Prevention Signs and Tags	397
Danger Signs	397
Caution Signs	398
Exit Signs	398
Safety Instruction Signs	398
Directional Signs	398
Traffic Signs	398
Accident Prevention Tags	398
Additional Rules	399
Signaling	399
Crane and Hoist Signals	399

Barricades _____	399
Part 17: Stairways & Ladders _____	401
Introduction _____	401
Basic Terminology _____	401
SCA General Requirements _____	401
General Requirements _____	402
Stairways _____	402
Temporary Service _____	403
Stairrails and Handrails _____	403
Ladders _____	404
Use _____	407
Training Requirements _____	409
Part 17 Appendix A: Ladders _____	411
Ladders _____	411
Structural Ramps and Runways _____	411
Platforms _____	412
Special Requirements for Power Buggies _____	412
Part 18: Steel Erection _____	415
Introduction _____	415
Basic Terminology _____	415
Scope _____	415
Site Layout, Site Specific Erection Plan and Construction Sequence _____	417
Hoisting and Rigging _____	417
Structural Steel Assembly _____	419
Column Anchorage _____	421
Beams and Columns _____	422
Open Web Steel Joists _____	423
Attachment of Steel Joists and Steel Joist Girders _____	424
Landing and placing loads _____	424
Systems Engineered Metal Buildings _____	425
Falling Object Protection _____	426
Training _____	427
Part 18 Checklist: Pre-Steel Erection Checklist _____	429
Part 18 Appendix A: Site-specific Erection Plan _____	435

Guidelines _____	435
Part 18 Appendix B: Testing Slip-Resistance of Walking/Working Surfaces. _____	437
Complying With Slip Resistance of Skeletal Structural Steel _____	437
Part 18 Appendix C: Illustrations of Bridging Terminus Points _____	439
Part 18 Appendix D: Illustration of the Use of Control Lines to CDZs _____	441
Illustration of the Use of Control Lines to DZs _____	441
Part 18 Appendix E: Training _____	443
Training Requirements _____	443
Part 18 Appendix F: Perimeter Columns _____	445
About Perimeter Columns _____	445
Part 18 Appendix G: Guardrail Systems _____	447
Fall Protection Systems Criteria and Practices _____	447
Safety Net Systems _____	448
Part 18 Appendix H: Drawings _____	453
Illustration of a Clipped End _____	453
Staggered Connections _____	454
Part 19: Welding & Cutting _____	455
Introduction _____	455
SCA General Requirements _____	455
Cylinders _____	456
Fuel Gas _____	456
Hose _____	457
Torches _____	458
Regulators and Gauges _____	458
Oil and Grease Hazards _____	458
Arc Welding and Cutting _____	458
Ventilation and Protection in Welding, Cutting and Heating _____	460
Part 19 Form: Hot Work Permit Procedure _____	463
Glossary _____	467

Table of Forms

Job Site Incident/Accident Form	41
C2- New York State Employer's Report of Work-Related Accident/Occupational Disease	45
Contractor Designated Competent Site Supervisor	47
Subcontractor Competent Foreman	57
Receipt of Safety Manual for Special Projects	79
Confined Space Entry Procedure Worksheet	97
Notification of Crane (NOC)	127
Sample Crane Inspection	131
Site Safety Plan Submission	303
Site Safety Plan Sign-Out Sheet	315
Hot Work Permit Procedure	463

Table of Checklists

Preconstruction Safety	61
Safety Unit Pocket Guide	67
Pre-Lift Setup Checklist	123
Sample Pre-Excavation	213
Trench & Excavation	217
Temporary Heating Plan	245
Hot Work Checklist	253
Pre-Roofing Safety Checklist	257
Site Safety Plan Checklist	319
Sidewalk Bridge Inspection	323
Daily Supported Scaffold Inspection Version 1	381
Daily Suspended Scaffold Inspection Version 1	385
Daily Supported Scaffold Inspection Version 2	389
Daily Suspended Scaffold Inspection Version 2	393
Pre-Steel Erection Checklist	429

Preface

INTRODUCTION

The NYCSCA has established this Safety Program & Procedures Manual, herein after called “SCA Safety Manual” in order to guide and direct the management, staff, and contractors working on all NYC school buildings of their obligation to adhere to the policies and procedures set forth within this program thereby promoting a safe work environment for all SCA personnel, school occupants, workers and the general public. In addition, every Contractor/Subcontractor is responsible to provide a safe working environment for each of its employees that meet all current City, State and Federal safety laws, standards and regulations. In the event there is a conflict between any governing safety regulations the highest standard established by either or any shall apply. The primary focus will be to prevent injury and property loss or damage to the public such as the school occupants, pedestrians and workers as a consequence of negligence and wrongful acts of commission or omission by Contractor employees or SCA Personnel. The New York City School Construction Authority (NYCSCA) is committed to safety and considers effective safety management a shared responsibility. Each employee of an Owner Controlled Insurance Program (OCIP) eligible contractor, regardless of position, shall be required to accept their safety responsibilities and shall be held accountable for such performance.

OBJECTIVES OF THE PROGRAM

The intent of this program is to assist the SCA in using every practicable means to protect school personnel, public and workers from accidents and health hazards. Its objectives are to develop and maintain a safe and healthful workplace, which promotes safe behaviors, compliments production, and avoid both injuries to persons and damage to NYC School property and adjacent structures. SCA Management and supervisors will ensure the use of protective equipment and controls to minimize the potential hazards of the work or as the activity requires. This will apply to all SCA and Contract operations. Both the Construction Management Division and the SCA Safety Unit are committed to the program and its strict enforcement.

THE MISSION OF THE NYCSCA SAFETY UNIT

Educate SCA Personnel, General Contractors, and Subcontractors of current City, State, Federal and SCA mandated safety rules and regulations. Accident prevention will be an integral part of all Construction procedures.

Enforce all current applicable safety rules and regulations in a firm, fair and consistent manner.

Provide optimum protection to the students, teachers, school personnel, and the general public during all new construction and renovation of NYC School Buildings. The SCA Safety Unit will seek to implement and maintain an effective and comprehensive safety program to prevent and/or reduce potential exposure to construction hazards and minimize accidents/incidents.

USING THIS BOOK

Before using The New York City School Construction Authority Safety Program & Procedures Manual, it is important to understand the terminology and symbols used in this manual.

Basic Terminology

Term	Definition
Capital Improvement Project (CIP)	A smaller project consisting of one or more capital category, i.e. roof and boiler replacements, electrical work, security systems, room conversions, and transportable classrooms. CIP projects may not have their own budgets; many CIP projects will be funded by one Certificate to Proceed (CP).
Competent person	A person capable of identifying existing and predictable hazards in the surroundings or working conditions which are unsanitary, hazardous, or dangerous to employees, and who has authorization to take prompt corrective measures to eliminate them.
Contract	A written agreement by and between the owner and a contractor/subcontractor or between a subcontractor and their subcontractor(s).
Contractor, Subcontractor, and Sub-subcontractor(s)	Any individual, firm or corporation pre-qualified and/or approved by the SCA to perform work on an SCA Project.
Emergency Work	Work to be done immediately to correct a hazardous condition.
Employer	A contractor, subcontractor, or sub-subcontractor(s).
General Contractor (GC)	Prime contractor performing the construction work.
General Contractor Safety Coordinator	Employee of the GC that is responsible to coordinate project safety with all contractors and sub-contractor of any tier. The general contractor safety coordinator works with the GC, the SCA, and insurance company safety personal to promote a safe working environment on the specific SCA project.
Insured	Includes the owner, et al, and the CM, GC, subcontractor or sub-subcontractors.

Term	Definition
Line Project	A major project such as a new school, major modernization, addition or athletic field. Line project may involve many capital categories or types of work in one project and are funded through their own OMB Certificate to Proceed (CP).
Occupied School Building/Premise/Project	Any building occupied by school children, educational program participants, educational staff or school administrators at anytime including but not limited to before and after school hours, weekends, and holidays.
OCIP	Owner Controlled Insurance Program – Owner (NYCSCA) provides liability and workmen’s compensation for all approved contractors and sub contractors
Owner	New York City Department of Education (DOE)
Owners Representative	New York City School Construction Authority (NYCSCA)
Photo I.D.	Information badge worn while on any occupied SCA project. The photo I.D. is to be readily visible at all times and is to contain a clear, current photo; the name of the person in the photo; the name of the company the person is working for; along with the address and phone number of the company.
Public	Any individual that is not part of the construction personnel.
Qualified	One who, by possession of a recognized degree, certificate, or professional standing, or who by extensive knowledge, training, and experience, has successfully demonstrated his ability to solve or resolve problems relating to the subject matter, the work, or the project.
SCA Insurance Administrator	An employee of the owner’s representative responsible for obtaining certificates of insurance, providing claims servicing, and auditing insurance related controls.
Servicing Insurance Broker	The broker representing the NYCSCA who issues Certificate of Insurance to contractors prior to working on projects.
Subcontractor, and Sub-subcontractor(s)	Any individual, firm or corporation pre qualified and/or approved by the SCA to perform work on SCA projects.

Symbols



The **Attention** icon represents important information that the reader must consider while working on a procedure or requirement.



The **Example** icon represents an example or further explanation designed to help the reader further understand the concept or requirement being introduced.



The **Exception** icon identifies when a procedure, requirement, or object type does not apply to the section.



The **Note** icon represents information that is of special interest to the reader. It alerts the reader to useful information which might indicate a shortcut or make it easier to complete a procedure or requirement.



The **Requirement** icon represents information that the reader needs to know before completing the procedure or task.



The SCA Requirement icon represents a standard which may be more stringent than other government standards.



The **Warning** icon represents critical information, that if ignored can cause harm or the inability to complete a procedure.

Part 1: Introduction

RESPONSIBILITIES

School Construction Authority Project Team Responsibilities

All levels of SCA Management are responsible for providing a work environment which maximizes occupational safety and minimizes hazards to the occupants, SCA and Contractor Personnel and the Public. Employees are expected to give complete support and cooperation to all phases of safety programs. This includes compliance with established rules and regulations applicable to their own actions and conduct; use of personal protective equipment; and otherwise performing their duties in a safe manner. Each employee is entitled, as well as expected, to report all job-related unsafe and unhealthy working conditions to his/her supervisor. All supervisors are expected to correct adverse conditions brought to their attention. Every School Construction Authority (SCA) employee and every SCA representative is responsible to be properly attired; to possess and wear, in a visually prominent location a photo identification tag; and to wear appropriate personal protective equipment (PPE), including hard hat and work boots, when physically present on any active SCA construction project.

Role of the SCA Safety Unit

Serve as principal staff advisor and technical consultant on safety matters. As such it shall provide direction, guidance and coordinate the efforts of both management and supervisors in planning, directing and evaluating all safety program elements and interpreting safety policies and procedures. In furtherance of these efforts it shall:

- a. Arrange and conduct ongoing safety training seminars for SCA Staff, Contingent Staff, consultants and Contractors.
- b. Provide technical assistance in the filing of accident and investigation reports to ensure that they are complete and accurate. Collect, analyze and disseminate data concerning the accident experience. Maintain accident information and records.
- c. Develop recommendations for corrective measures and accident prevention programs.
- d. Review Site Safety Plans submitted by Contractors
- e. Prepare monthly safety status reports for the President and CEO, Vice President, Environmental and Regulatory Compliance (VP ERC), Director Safety Unit, Vice President Construction Management (VP CM) and Chief Project Officers (CPO's)
- f. Inspect work sites and issue safety inspection reports to Construction Management: Project Officers (PO), Senior Project Officers (SPO's), Chief Project Officers (CPO's) and Vice President Construction Management (VP CM)
- g. Verify, through site inspections, that applicable safety rules and regulations are implemented and code compliance is being applied.

SCA Safety Director Responsibilities

1. Making periodic field inspections of work areas to monitor contractor's safety activities and enforce the School Construction Authority Safety Manual.
2. Interfacing with Construction Management, and General Contractor's senior management and safety representatives for the total elimination of unsafe conditions and/or acts as necessary.
3. Advising the Project Officers in the following areas:
 - a. Accident investigation.
 - b. Preparation for pre-construction meetings, safety meetings, etc.
 - c. Required contractor training.
 - d. Referring Health issues such as asbestos and lead to the School Construction Authority Industrial Hygiene Division (IEH)
 - e. Development of statistical information for accident/injury tracking and trending.
 - f. Accompany officials on inspections.
 - g. Determine personal protective equipment needs.
 - h. Provide education and reference materials as requested for specific safety related issues.
4. Overseeing the Safety Officers written Safety Compliance Inspection Reports; Follow-up Inspection Reports; 24-Hour and 48-Hour Notice; Stop Work Orders; and Releases from Stop Work Orders.
5. Providing direction to Safety Officers with regard to site specific emergency situations.
6. Conducting Hazard recognition surveys (workers compensation and general liability) and furnishing reports to the Project Officer with copies to OCIP, and the School Construction Authority CPO, PO, CM, and GC as necessary.
7. Produce monthly safety report that summarizes loss control activity.
8. Provide expert advice and support to SCA as requested.

SCA Safety Officer Responsibilities

1. Reviewing approved site safety plans to ensure contractor's compliance.
2. Reviewing Contractor's training records, Permits and Licenses relevant to site specific construction activities.
3. Conducting un-announced site specific safety compliance inspections on all assigned projects. Inspections shall include but not limited to the active work areas, staging/material storage areas, scaffolding and perimeter sidewalk bridging.
4. Identify site specific safety deficiencies and discuss safety recommendations for correction and compliance with the Site Supervisor and Project Officer and sometimes the Competent Foreman of various trades.
5. Provide written Safety Inspection Report and photos within 24 hours of conducting Safety Inspections. Reports shall be distributed to Project Officers (PO's), Senior Project Officers (SPO's), Chief Project Officers (CPO's), SCA Safety Director and VP of Environmental and Regulatory Compliance.
6. Issuing Stop Work Orders to the Contractor to cease any operation (s) which poses an imminent danger to workers, school occupants or pedestrians. Stop Work Orders shall be issued to Contractors on projects requiring site safety plans when the contractor has failed to provide same. Stop Work Order is to be distributed to the Contractor, Project Officer, Senior Project Officer;

Chief Project Officer; VP of Construction Management and VP of Environmental and Regulatory Compliance (ERC).

7. Conducting 72 hour re-inspection of jobsite when a Stop Work Order has been issued.
8. Conducting an accident/incident investigation as directed by the Safety Director and submitting a written report in regard to relevant circumstances.
9. Discussing problems relating to safety with the SCA Safety Director; the SCA Project Officer; and appropriate site personnel.
10. Attend and participate in safety meetings either during regular surveys or upon request of the SCA field representatives. Pre-construction meetings for major operations to introduce safety standards that are required of trades during the operation.

Senior Project Officer (SPO) Responsibilities

1. Managing projects within their assigned borough. Enforce contract requirements for all safety procedures and programs.
2. In accordance with the policy and directives of the SCA, prepare and issue written instructions to all supervisory and inspection personnel under his/her jurisdiction. These instructions will outline their responsibilities for accident prevention and provide methods of enforcing the safety regulations at the jobsite.
3. Assigning a Project Officer (PO) to each school project.
4. Hold periodic safety meetings with the SCA supervisory personnel under their supervision and with the Contractor's senior management on site.
5. Remain currently advised of the accident history and the accident prevention status of all work under their supervision including the maintenance of a continuing record of each contractor's safety performance.
6. Personally investigate all serious accidents and ensure that all other accidents are properly and fully investigated by SCA Personnel.
7. Overseeing activities among Project Officers; Construction Managers (CM) and General Contractor (GC) .
8. Holding periodic meetings to assess safety compliance and activities with above-mentioned personnel.

SCA Project Officer (PO) Responsibilities

1. Planning and executing all work in order to comply with the stated objectives of the "SCA Safety Manual" and loss prevention responsibilities. This includes security on the job site.
2. Prior to allowing the start of work, the PO shall obtain a Site Safety Plan from the Contractor and submit to the Safety Unit for review. The Site Safety Plan (4 copies) shall be accompanied by the Site Safety Plan Submission Form. No field work shall commence until the Plan is approved and returned to the PO and implemented at the site..
3. Requiring the General Contractor's (GC's) safety representative be present for all weekly and/or other special scheduled safety meetings.
4. Working in conjunction with School Construction Authority Safety Director as well as assigned School Construction Authority Safety Officers.
5. Requiring compliance with all applicable federal, city, and state safety and health standards (e.g., NYC Chapter 33, Industrial Code Rule #23, OSHA 1910 where applicable, and OSHA 1926) and all SCA mandated safety requirements.

6. The responsibility for the enforcement of the safety provisions of a contract rests with the Project Officer. Prompt action at the field level should be taken to correct deficiencies. If the PO cannot gain immediate compliance from the Contractor, the PO shall immediately refer the matter to the SPO and CPO for Construction Management. The SCA PO shall verify the Contractor's Safety compliance within 24 hours of receipt of the Safety inspection report. Written verification response shall be distributed to the same recipients of the original safety report, ie. CPO, SPO, PO, Safety Director, Safety Officer, and Administrative Staff. .
7. Authorizing necessary action when the deficiencies remain uncorrected beyond the time frame established in the safety report . The Project Officer is to initiate a work authorization request for an on call contractor to correct all open deficiencies in accordance with current Construction Management Policy & Procedures Manual .
8. If all reasonable attempts to have the Contractor comply with the site safety plan or other applicable safety procedures have failed, the PO will issue a stop work order. The PO will maintain a written record of the violation(s) found and steps taken to secure the Contractor's voluntary compliance. The PO shall immediately stop work on any operation that poses an immediate danger to students, school or SCA staff, pedestrians or workers. Contractor Evaluation – Stop Work Orders will be reviewed by Construction Management to determine if the Contractor is to be issued an “unsatisfactory” or “marginal” evaluation.
9. Review and sign all accident reports for accidents occurring at jobsites under their supervision. Ensure that the reports are complete and that the action indicated to prevent a recurrence is adequate and effective. Where such action is deemed inadequate, the appropriate action will be noted in the report. Steps are to be taken to ensure that the appropriate measures are implemented.
10. Walking through an on-site safety inspection with the assigned School Construction Authority Safety Officer, or representative of the SCA Insurance Provider or Broker.
11. Report to SCA Safety Officer all accidents, injuries and occurrences at the time of the event. Obtain the required documentation from the injured worker/contractor's job foreman or competent person of the operation that involved the injury or property damage, such as the SCA Jobsite Incident Report (attached herein) within 24 hours of the accident. The SCA's Insurance company is to be notified within 24 hours and an Employer's Report of Work-Related Accident/Occupational Disease, C-2 (attached herein)is to be completed and submitted. Distribute documents in accordance with the Reporting of Accident/Incident or Damage section included herein.
12. In the event of a potential asbestos or other hazardous materials release contact the SCA Director of IEH (Industrial & Environmental Hygiene) immediately.

Contractor and Contractor's Personnel Responsibilities

General Contractor

The General Contractor responsibilities include:

1. Presenting a corporate Safety and Health Program describing policies and procedures for total management of the safety and health environment of its employees and all other persons and property affected by its construction operations. These policies and procedures should be in the form of a Job Safety Analysis or detailed means & methods addressing the anticipated exposures of the job.
2. Providing a competent Site Supervisor on site at all times during construction including when sub contractors are present. On all projects less than \$500,000, the competent Site Supervisor shall possess at a minimum a 10 Hour OSHA Certification and for all projects above \$500,000, competent Site Supervisor shall have a 30-Hour OSHA Certification or a 40 hour Site Safety Manager's certification from NYC Department of Buildings. The OSHA certification shall be issued within the previous (5) years. Where applicable the site supervisor shall be a “Registered

Superintendent” in accordance with the rules established by the New York City Department of Buildings.

3. Obtaining all required permits and submitting the required site safety plans to SCA Safety Unit.
4. Designation of site specific competent site Supervisor (form attached herein)and safety representative as well as Competent foreman for each subcontractor (form attached herein) with emergency contact phone numbers for all key personnel (24 hrs/day-7days/wk)
5. Compliance with all City, State and Federal safety laws and regulations as well as SCA policies and procedures within the SCA Safety Manual.
6. Contractor's superintendent or safety supervisor is required to report accidents or injuries immediately upon happening but no less than 24 hours after the occurrence. Form C-2 is to be filled out and submitted to the SCA within 24 hours with all pertinent information. (Reference Accident/Incident reporting format contained herein)
7. Reporting a work related fatality immediately to the School Construction Authority Safety Director; Project Officer; Local authorities; OSHA within eight (8) hours; and NYCDOB (B.E.S.T. Squad).
8. Enforcing the use of Personal Protective Equipment (PPE) as specified by OSHA 29 CFR, Part 1926 and SCA Safety Manual. PPE is also recommended in certain applications as dictated by Material Safety Data Sheets.

9. Corrective action which is to be taken at the time of the safety inspection but not more than 24 hours from issuance of the safety inspection report. Immediate compliance is encouraged and will be noted as such in the safety report.
10. Providing written verification to the SCA Project Officer of the corrective action(s) taken for safety observations.
11. Cooperation with SCA Project Management and the Safety Unit during all pre-planning, audits and accident investigations.
12. A safety orientation for newly hired employees described in the contractor’s Safety Program.
13. Providing proper training and education to employees. All workers performing work at the site are required, at a minimum, to possess a 10 Hour OSHA Construction Training Certification Issued within the previous 5 years.
14. Documenting and submission of daily safety inspections, toolbox meetings and all contractor weekly safety meetings.
15. Maintaining proper control of hazardous products (Hazard Communication Program, Storage and Use)
16. Recognizing and controlling excessive noise levels.
17. Contacting all underground utilities companies for proper Mark Out before work begins.
18. Providing approved and appropriate equipment for the project
19. Providing each employee all required personal protective equipment for the task they are involved in.
20. Reporting all accidents/Incidents and damages (reference accident/incident reporting format contained herein) to the proper authorities and to the SCA immediately.

General/Prime Contractor's Designated Competent Site Supervisor

The General Contractor’s Designated Competent Site Supervisor responsibilities include:

1. Requiring each sub-contractor to comply with appropriate Federal, State and City safety requirements and with the School Construction Authority Safety Manual.
2. Requiring each sub-contractor to submit a written safety program, which will describe hazards and controls necessary (in Job Safety Analysis or means & methods format) during the sub-contractor's work. Each sub-contractor shall designate a competent Foreman to implement their own program.
3. Scheduling, attending and documenting weekly safety meetings.
4. Cooperating with the owner and School Construction Authority Safety Officers.
5. Requiring contractors and each sub-contractor's superintendent and job foreman to be familiar with provisions of the "Safety and Health Regulations for Construction" (Federal Register Title 29, Part 1926), applicable State and Local laws; and SCA Safety mandated requirements.
6. Instituting procedures for preparation of supervisory investigation reports on all accidents.
7. Reviewing accidents and institute corrective action to prevent recurrence.
8. Reviewing safety meeting reports submitted by contractor and take necessary action to see that required weekly "tool box" safety meetings are held by contractor. Provide contractor's job superintendents with appropriate material that is relevant to site conditions or the work being conducted for use in conducting weekly "tool box" safety meetings. Periodically attend contractor "tool box" safety meetings and evaluate effectiveness.
9. Conducting daily safety inspections of job site and directing contractor safety representatives to take necessary corrective action to eliminate unsafe acts and/or conditions.
10. Cooperating with School Construction Authority Safety Officers and taking necessary steps to implement appropriate recommendations. Advise School Construction Authority regarding safety on the job as requested.
11. Coordinating all tours and visitors to the site. All visitors must be identified, be accompanied by a contractor representative, and have proper personal protective equipment. (Minimum hard hat and work boots and proper photo Identification badge visibly worn)
12. Providing project safety orientation to all contractors. Ensure full understanding of School Construction Authority Safety Program and Procedures Manual .
13. Prepare and maintain at jobsite a current site specific emergency evacuation plan.
14. Requiring all employees to properly use PPE, such as hard hats, glasses, gloves, appropriate clothing, respiratory equipment and others as needed
15. Stopping any operation in which they identify an imminent danger to life and health (IDLH).
16. Assuring that a workable housekeeping program is in place, assigning definite duties to individual contractors, making daily check of work areas, keeping records of conditions found and corrective action taken.
17. Assisting in the investigation of accidents with the safety representative to determine facts necessary to take corrective action and promptly copy written results of investigation to the SCA safety Officer, and the SCA Project Officer

General/Prime Contractor's Safety Representative

The Contractor's Site Safety Representative Responsibilities include:

1. Holding the contractor and subcontractor senior management responsible and accountable for the safety of their employees. Conditions identified should be communicated to contractor management for correction.

2. Enforcing corporate Safety & Health Program, SCA Safety Manual and any special controls issued by SCA safety inspector or Project Officer.
3. Participating with Project Officer and SCA safety inspector in making a pre-job safety survey prior to commencement of job and whenever requested.
4. Communicating safety information to respective contractors and subcontractors regarding hazards that may arise from daily operations.
5. Conducting weekly tours through assigned construction areas with contractors and subcontractors; and submit written report to Project Officer. Include comments from inspections on the following critical areas:
 - a. All rigging equipment, including ropes, slings, shackles, blocks, hooks, fall protection systems, elevated work platforms (scaffolds), and ladders.
 - b. Tools and pneumatic equipment.
 - c. Major equipment, such as cranes, derricks, hoists, tow motors, welders,
 - d. Safety equipment.
6. Personally reviewing all accident scenes when notification is received from the contractor or subcontractor. Complete accident report as per contractor's and SCA Safety Manual.
7. Assisting with developing and communicating safe job procedures for unusual or hazardous operation.
8. Enforce compliance with federal, state, city and/or other agency requirements.
9. Assisting in the investigation of accidents with the safety representative to determine facts necessary to take corrective action and promptly copy written results of investigation to the SCA safety officer, and SCA Project Officer

SUBCONTRACTOR'S RESPONSIBILITIES

All Subcontractor's shall be responsible for the following:

1. The safety of its personnel and executing all work in compliance with this safety manual, OSHA, and all applicable federal, state and NYC codes.
2. Providing copies of a written Safety Program and Hazard Communication Program, with corresponding, current Material Safety Data Sheets (MSDS), to the contractor's project safety representative or the SCA on site representative.
3. Attending the safety meetings scheduled by School Construction Authority Project Officer or their representative.
4. Communicating any unsafe practices or conditions observed which are not under subcontractor's jurisdiction to the Contractor's Superintendent.
5. Ensuring that adequate First Aid Supplies are available and that personnel are qualified to administer First Aid as required by State and/or Federal Regulations. The First Aid kit shall be stocked with necessary items relevant to operations.
6. Contractor's superintendent or safety supervisor is required to report accidents or injuries immediately upon happening but no less than 24 hours after the occurrence. Form C-2 is to be filled out and submitted to the SCA within 24 hours with all pertinent information. (Reference Accident/Incident reporting format contained herein)

7. Reporting a work related fatality immediately to the School Construction Authority Safety Director; Project Officer; Local authorities; OSHA within eight (8) hours; and NYCDOB (B.E.S.T. Squad).
8. Enforcing the use of Personal Protective Equipment (PPE) as specified by OSHA 29 CFR, Part 1926 and SCA Safety Manual. PPE is also recommended in certain applications as dictated by Material Safety Data Sheets.
9. Provide SCA supervisory investigation reports as found in this Manual on all accidents. Report should state recommendation(s) and action taken to help prevent recurrences.
10. Schedule and document weekly "tool box" safety sessions for all employees. Pre-printed forms with different topics are available from various industry sources. The topics selected should be relevant to site conditions or the actual work being conducted.
11. Perform regular (documented) safety inspections. Take immediate action to correct unsafe practices or conditions when discovered or reported.
12. Implementing and maintaining a Hazard Communication Program with corresponding Material Safety Data Sheets (MSDS) for all hazardous materials on the job site. Conduct necessary training and enforce required use of PPE. Documentation must be maintained as per the hazard communication requirements and made available for review.
13. Providing proper training to all employees

Subcontractor's Competent Job Foreman

The Subcontractor's Competent Job Foreman responsibilities include:

1. Evaluating workers' experience prior to assignment to assure that worker is properly trained in the task and understands the hazards involved.
2. Ensuring all workers under his/her supervision are trained in safe work practices and methods in accordance with Subcontractor's Safety Program.
3. Enforcing all employees to have and use proper protective equipment (PPE) and suitable tools for job.
4. Continuously assuring no unsafe practices or conditions are allowed to exist on any part of his/her job. If unsafe conditions are identified, foremen are responsible for eliminating or controlling them and, if outside their jurisdiction, reporting them to job superintendent or safety representative.
5. Setting a good example for his/her employees through the use of personal protective equipment (PPE) as required.
6. Assisting in the investigation of accidents with the safety representative to determine facts necessary to take corrective action and promptly copy written results of investigation to the safety manager, SCA safety representative and the Project Officer.
7. Conducting weekly "tool box" safety meetings with employees to:
 - a. Promote safety awareness
 - b. Review the hazards and controls needed to complete the work.
 - c. Discuss observed unsafe work practices or conditions.
 - d. Communicate policies and procedures.
8. Assuring prompt first aid is administered to injured employee, while professional medical care is summoned.

9. Reporting immediately to project designated competent site superintendent any observed unsafe conditions, practices or violations of job security.

PUBLIC SAFETY

Keeping the School Community Safe

The General/Prime Contractor is ultimately responsible for public safety. The safety of the children, teachers, administrative personnel and the public is of the utmost importance. Performing construction activities in or near an occupied school demands the highest level of loss prevention. Every effort must be made to evaluate, eliminate and reduce the hazards posed to the school occupants and the public by projects that are concurrent with school activities. Our children are totally dependent on us to create a safe place for them to learn, study and play. Any work related condition deemed to be unsafe must be corrected immediately because children do not see the world as we do and are often victims of our own negligence.

Children are often attracted by what is new and alien to them and will try to gain access to what may seem to be great places to play and have fun. Therefore, it is the contractor's responsibility to control the potentially dangerous areas that exist within its construction project. Serious accidents involving school occupants are devastating to the children, families, school and the NYCSCA. Serious accidents also involve law enforcement, media, and political figures and reflect poorly on the project and the NYCSCA.

On Occupied Schools

1. A pre-construction survey of the site property, adjacent utilities, property, streets and operations must be performed prior to mobilization to assess surrounding exposures and current conditions of soils and nearby structures. The findings of this survey should be documented and should be a part of the planning process for the safety of persons and property during construction operations. These findings should also be reflected on the contractor's site safety plan.
2. Each contractor is responsible for the general housekeeping of their work area. In cases where more than one contractor is working in an area the responsibility of housekeeping is shared accordingly.
3. Work areas must be contained and kept free of debris on a daily basis. Construction supplies should be secured, (roofing, etc.) to minimize the potential of materials blowing off open areas. Only proper securing methods should be used. Use of brick, concrete block, wood or other unsecured material is prohibited.
4. Subcontractors shall also report any unauthorized individuals found on site, or holes made in the fence around the site, to security and the contractor's project safety coordinator.
5. The contractor must provide a level, un-obstructed and safe walkway for pedestrians. This walkway should not pose any unusual hazard to users. The walkway shall be adequately illuminated at all times. Walkways (and any required sidewalk bridge protection) must meet the requirements of the NYC Building Codes.
6. Traffic to and around the site should be controlled by the contractor. If heavy equipment, extra wide loads or some other unusual road hazard is introduced, the contractor should notify the proper authorities and have the appropriate trade provide flag person (s) to direct local traffic. All requirements of the NYC Department of Transportation (DOT) shall apply (including obtaining appropriate permits as necessary)

7. A minimum eight foot high (8') fence with fine mesh netting must be installed around the perimeter of the construction site (reference section under Public Protection contained herein). Fence construction and location must meet the requirements of the NYC Building Code and contractor's permit application including the approved Site Safety Plan.
8. Security Guards shall be on site, as per contract requirements, once site mobilization activities have commenced.
9. Security should make periodic rounds of the area. Security must not allow the general public access to the worksite for any reason. Security should address these individuals firmly but politely. If an unauthorized individual is found on property the matter should be immediately reported to NYC Police and the contractor's project safety coordinator.
10. Public safety shall comply with NYC, Building Code (Chapter 33) titled, "Safeguards During Construction and Demolition"; NYS Code Industrial Code Part 23, titled, "Protection in Construction, Demolition and Excavation Operations"; and all applicable State and city regulations including SCA safety mandated requirements.
11. Discuss the work activities to be performed with the school administrator or designated person prior to the commencement of construction activity.
12. Never leave tools and equipment unattended while in occupied areas.
13. No Hot Work is permitted in a school where children and teachers/staff are present. All proper FDNY and SCA mandated regulations must be followed.
14. Maintain good housekeeping at all times. Never create piles of debris or materials in areas occupied by children/teachers and leave the piles unattended. Remove debris before end of work day. Do not leave overnight.
15. Separate and protect work areas from occupied areas with cones, barriers, or other temporary barricades if workers must leave a work area momentarily.
16. Never leave compressed gas cylinders unattended or overnight on occupied schools.
17. Maintain doors or gates closed/secured when these open directly into occupied areas. Use security service if necessary.
18. Follow the safety instructions found in the SCA Safety Manual. If a situation arises that is not covered by this manual, or other safety documents referred to in number 10 above, please contact your SCA Project Officer, and assigned SCA Safety Officer.
19. Never leave exposed electrical box panels, even during breaks. Cover exposed boxes physically with the panel cover, and protect area with barricades if necessary. Keep electrical rooms/closets locked.
20. Tour all work areas regularly, especially if the type of work being done is deemed to create problems and exposures to accidents. Make sure that unsafe conditions are corrected before leaving scene of work.
21. Dust/Noise Control: These should be controlled properly to allow the school to maintain its teaching schedules without interruptions. Treat every request or complaint as real and immediately establish control measures.
22. The requirements of NFPA 101, Life Safety Code for Occupied Schools must be maintained during construction. Separate atmospheres must be maintained between the school areas in full occupancy and the areas under construction. Construction activities must not be able to interfere or interrupt the normal teaching schedules. Means of egress for the school occupancy must be maintained free of obstructions, clean and illuminated. While this may be a function of the school custodian, no construction related operations must be allowed to cause an impairment of the normal means of egress facilities. In addition, existing smoke detection, communications, fire suppression and alarm systems must be maintained during construction.

23. Exit doors throughout the premise are not permitted to be permanently closed, altered, locked or blocked by the school, contractor or SCA without first obtaining an on site inspection from the New York City Fire Department. Such inspection shall be duly documented and made readily available for review.
24. Holding areas must not be blocked, proper access shall be provided in accordance with FDNY regulations.

SAFETY MEETINGS

Pre-Construction Meeting

1. Prior to the start of construction activities on all School Construction Authority Projects, a pre-construction meeting shall be convened by the Project Officer. One of the agenda items shall be safety and the following shall be discussed at a minimum (See attached checklist) .
 - a. Site-specific project exposures.
 - b. Site Safety Plan and logistics of Staging area, fencing, etc.
 - c. Planned controls to meet health and safety requirements of the project.
 - d. Designated safety contacts.
 - e. Roles and responsibilities.
 - f. First aid and medical services.
 - g. Accident reporting and investigation.
 - h. Site security.
 - i. Other safety related items.
2. Minutes of meeting are to be recorded by the SCA Project Officer and distributed to all those in attendance.

Job Site Safety Meetings

Weekly Contractor Safety Meeting

1. The contractor's safety representative and/or designated competent site supervisor shall be responsible for chairing and presenting appropriate subject matters at these meetings.
2. The subject material shall be typed and reproduced for distribution at the meetings. A sign-in sheet shall be maintained and be readily available for inspection by the SCA Safety Officer.
3. The actual meeting time shall not exceed 30 minutes except in unusual circumstances. It is important to keep in mind that the length of the meeting is not necessarily an indication of its effectiveness. Once established, the day, time and place of the meeting should not be changed unless absolutely necessary.
4. Contractor and sub contractor attendance at these meetings is mandatory. The following items shall be covered at these meetings:
 - a. Previous week's minutes. A discussion of the safety hazards for the upcoming week's work.
 - b. The review of first aid cases and those, which required medical attention that, have occurred since the previous meeting. Include accident prevention methods to be initiated

by individual contractors. The chair person shall encourage group discussions on methods of correction, improvement, etc., of safety problem areas that may exist on the project.

- c. Review of the most frequently noted serious and non-serious, and repeated safety violations, including corrective action that will be necessary to eliminate their recurrence.
 - d. A "safety topic-of-the-week" shall be chosen for discussion with a handout distributed. These topics may be general in nature, but specific towards construction safety, e.g., scaffolds, ladders, personal protective equipment, etc. and be relevant to current site conditions and/or work underway
5. The minutes of these meetings shall be maintained. Distribution of the minutes should be as follows:
- a. Attendees
 - b. SCA Project Officer
 - c. SCA Safety Officer

Weekly Contractor/Subcontractor Tool Box Safety Meetings

- Once a week each competent foreman will hold a safety meeting with the workers under their supervision to discuss work practices and conditions related to construction safety.
- While the foreman are expected to discuss safety matters specifically related to their crew's upcoming activities, additional material such as the previous week's accidents and the "safety topic-of-the-week", shall be provided by the contractor with respect to the last contractor safety meeting.
- Each foreman shall make a record of the meetings by means of a form. The completed form is forwarded to the contractor. The contractor is required to acknowledge their review of this report and enter appropriate comments. These records are subject to monitoring by the SCA.
- Attendance at these safety meetings is mandatory. Once established, the day, time and location of these meetings should not be changed unless absolutely necessary. A written roster of those in attendance will be maintained and forwarded to the contractor.
- Under normal circumstances, these meetings shall last no longer than 10 to 15 minutes. Items of discussion at these sessions shall be restricted to safety-related matters.
- The contractor's safety representative shall attend these meetings periodically as an observer or to discuss safety matters of special concern.

Project Safety Bulletin Boards

1. In order to promote safety and maintain a highly visible safety profile on the work site, the project shall establish safety bulletin boards. It is the responsibility of the contractor's site safety representative to see that the material on the bulletin board is kept current.
2. Bulletin boards may be fabricated on the job and will be of sufficient size to accommodate the following material:
 - a. Appropriate Occupational Safety and Health and Workers' Compensation information posters.
 - b. Emergency phone numbers, i.e., fire department, ambulance, hospital, etc.
 - c. Project permits.
 - d. Approved Site Safety Plan.
 - e. Appropriate safety posters.

- f. Site Specific Emergency Evacuation Plan
- g. Where applicable PE designed scaffold/sidewalk bridge drawings
- h. Emergency Contact Number for Key Personnel on the site.
- i. Designated Competent Site Supervisor form to be posted
- j. Contractor's OSHA 300 Form (Log of work –related Injuries and Illnesses) must be posted in accordance with OSHA requirements.
- k. A general message to all employees indicating the commitment to safety. An example is as follows:

<p><u>To All Employees</u> Your continued employment on this project is dependent upon your willingness to cooperate with our safety program. We believe in and insist upon safety on this SCA project.</p>
--

ENFORCEMENT

Contractor Safety and Health Monitoring

Contractor safety and health monitoring enforcements include:

1. Contractors and all Subcontractors shall be required, in accordance with OSHA regulations and contract inclusions, to comply with all safety directives. When a contractor fails to correct unsafe conditions, the SCA Project Officer shall undertake corrective actions, and deduct the cost from the responsible contractor's progress payment.
2. Repeated violations, or lack of cooperation with regard to these procedures, may be cause for contract termination.
3. If necessary, the SCA reserves the right to have the contractor remove and replace a superintendent , or site safety representative.
4. Should an imminent dangerous condition be discovered, contractor must stop all work in the area of danger until corrections are made.

Enforcement Procedures

The success of the SCA Safety Program is dependent upon employee cooperation and strict compliance with established safety rules, regulations, policies, etc. While management and labor share safety responsibilities, the contractor must establish a policy by which habitual safety offenders are disciplined.

Those individuals who repeatedly refuse to cooperate with the SCA and the contractor's efforts in providing a safe place of employment for all employees shall be notified in writing and subject to removal from the project.

The safety orientation provided for new employees, as part of the contractor's safety program, shall reinforce the verbal message that violations of the Occupational Safety and Health Act and/or SCA Safety Manual may result in disciplinary action, as noted herein:

First Offense

Verbal Warning - In those instances where an employee is observed committing an unsafe act, the worker is to be informed that his actions are jeopardizing his or others' safety. The exact nature of the violation and what is acceptable is to be thoroughly detailed to the employee. The violation is to be brought to the attention of the employee's supervisor and an informal written note made and filed in both the contractor's and safety coordinator's offices.

Immediate Removal - Certain infractions to project rules are grounds for immediate removal (i.e., fighting, verbal abuse, physical abuse, use of alcohol or drugs, lack of documented training, IDLH (Immediate danger to life and health) situations, etc.).

Second Offense

Warning Letter - In the event that an employee is observed committing a second unsafe act, a formal safety-warning letter shall be issued. This letter will explain in detail the nature of the safety violation. Filing requirements as per #1 under First Offense – Verbal Warning.

Third Offense

Removal From Project - If an employee continues to engage in unsafe work practices and/or willfully violates safety procedures, he is subject to removal from the project.

WORKER'S SAFETY EDUCATION, TRAINING AND PROMOTION

General

A proven means for instituting and reinforcing the SCA Safety Manual is through a carefully planned and conveyed program of safety education, training and informational activities. These activities are to be presented as logically and systematically as possible to ensure that all employees know their obligations and responsibilities as they apply to the overall safety effort.

The general contractor must advocate different means in which these activities relating to work hazards and their controls are conveyed to the contractor's and sub contractor's employees. These activities include, but are not limited to OSHA 10 Hour Construction Outreach Training, New Hire Safety Orientation, Contractor Foreman Safety Orientation, and Employee Right to Know.

New Hire Safety Orientation

All newly hired contractor employees shall be required to attend a safety orientation prior to beginning their duties. This includes craftsmen, supervisors, office staff and subcontractor personnel.

In addition to above-referenced presentation, the following shall be discussed:

1. SCA and Contractor Safety Philosophy - The importance of health and safety matters, including desire to comply with federal/state/City and Safety and Health Act as well as the SCA Safety Manual.
2. Employees' Safety Responsibilities - Employees are to protect the health and safety of themselves and other workers and to cooperate with construction manager's safety effort.
3. First Aid - Reporting procedures for occupational injuries and illness shall be reviewed. Every injury, no matter how slight, shall be reported to that particular employee's foreman. Any employee who has obtained outside medical treatment for an alleged work site injury or illness must report his/her injury or illness and name of attending physician to his/her supervisor no later

than the first normal scheduled workday. Failure to comply with this policy may result in denial of workmen's compensation benefits and may be cause for termination.

4. "Tool Box" Safety Meetings - Every employee shall be informed that their attendance at scheduled weekly contractor "tool-box" safety meetings is mandatory. This weekly meeting shall allow employees to ask questions, offer suggestions and air complaints regarding safety on the project.
5. Reporting of Unsafe Acts or Conditions - Employees shall be expected to report all unsafe acts or conditions to their site foremen, who will either resolve problem or refer it to higher project authority. In cases of "imminent danger", first contractor or supervisor employee can find shall be informed of situation.
6. Employee Safety Warning Letters - This letter is to be utilized in warning of unsafe acts by contractor employees and shall be issued by contractor's site safety representative. It shall only be used in cases where an employee has repeatedly disregarded an established safety rule after he/she has been properly notified and instructed on proper procedures and rules. Employee who has received warning letter is subject to immediate removal from project.
7. Personal Protective Equipment - Every contractor employee is required to wear an approved hard hat, safety glasses and work boots at all times in designated areas. Each employee will be made aware that other forms of protective equipment (safety harnesses and lanyards, face shields, hearing protection, respiratory protection, etc.) may be required. If use of PPE is deemed necessary for specific work task, its proper use is mandatory. Repeated non-use of PPE when required shall be cause for removal from project.
8. Emergency Procedures - Each employee is to be briefed on established project emergency procedures so that they may render assistance in case of serious injury, fires, evacuations, etc.
9. A written record of all worker safety orientations will be completed and signed by the individual worker. This record will be maintained by the contractor with copies made available to SCA safety representatives as needed.

Contractor Designated Competent Site Supervisor(Site Supervisor)/Foreman Safety Orientation

The contractor's designated competent site Supervisor's /Foreman's daily involvement is important to the success of the contractors Safety & Health Program. It is necessary that contractor orientates each supervisor /foreman upon promotion or hire as to their safety responsibility that includes:

1. Safe Work Areas - The competent site supervisor/Foreman shall familiarize himself with his crews' work areas and ensure that safe conditions are maintained. If an unsafe condition should exist, it shall be the responsibility of the site supervisor/foreman to correct those conditions as soon as possible before the work tasks are started. If this proves to be unsuccessful, the appropriate contractor's safety representative must be notified, who will in turn initiate corrective action. The assistance of the SCA Safety Officer shall be sought where complex problem areas of concern exist.
2. Safe Work Practices - When site supervisor/foreman assigns work tasks, he/she shall ensure that they are instructed in safety practices, work methods and PPE required. The site supervisor/foreman is responsible for ensuring that his/her crew have proper PPE and use it at all times when the need exists. It is site supervisor's/foreman's responsibility to ensure that suitable tools are being used for a specific work task.
3. Supervising for Safety - Following progress of crews' work assignment, site supervisor/foreman shall constantly review safety practices and procedures being used and initiate corrective action as necessary.
4. "Tool Box" Safety Meetings - Each foreman is required to conduct a weekly "tool box" safety meeting with entire crew at a specified time and place using safety materials provided by contractor. Foreman is required to obtain a list of employees attending meeting and to list

comments and suggestions given and complaints aired for review by Contractor's Site Safety Representative.

5. Foremen's Safety Meeting - Contractor shall conduct a foremen's safety meeting on a weekly basis. Topics of discussion will be on safety as it relates to crew and work assignments. Attendance at these meetings is mandatory.
6. Emergency Procedures - Each Site Supervisor/foreman shall become completely familiar with project emergency procedure so that they can provide the needed leadership required in case of serious injury, fires, evacuations, etc.
7. Accident Investigations – Site Supervisor/Foremen are required to actively participate in reporting and investigation of incidents that result in:
 - a. Personal injury to a member of his crew.
 - b. Equipment or property damage in foreman's area of responsibility.
 - c. Non-injury incidents (near misses) that had potential to cause serious injury or loss.
 - d. Foreman shall be made aware that accident investigations are to determine facts, not faults, so recurrences can be prevented.
8. Fire Prevention - Each foreman should have a working knowledge of the FDNY inspection manual and is to maintain a state of constant awareness as to potential fire hazard in areas of his responsibility and know location of fire extinguishers. Hot work permits must be obtained before hot work is initiated. If potential fire hazard exists or is noted, foreman shall initiate corrective action or notify appropriate personnel for initiation of emergency fire fighting requirements from outside agencies.
9. Electrical Safety - Contractor shall designate one or more competent persons who are capable of identifying existing and potential hazards in surroundings or working environment which are hazardous to employees. Individual shall have authority to take prompt corrective measures to eliminate the hazards. These competent persons will be trained in the use of GFCI, LOTO, etc.
10. A written record of all foreman safety orientations will be completed and signed by the individual foreman. This record will be maintained by the contractor with copies made available to SCA safety representatives as needed.

Employees Right-To-Know - Hazard Communication Program

Trade contractors shall be required to identify, train and protect employees' handling of hazardous chemicals. Different trade contractors working in same areas of project shall be responsible for providing hazard information to others so that all workers are aware of, and properly alerted to hazards of materials being used.

Contractor's site safety representative must review each Trade Contractors Hazard Communication Program for completeness and maintain current MSDS sheets on file.

Hazard Communication Program should include following elements.

1. Management policy statement indicating employee's right to know of hazardous materials in work site or area, and how management intends to comply with standard.
2. Identification of exposed employees by taking an inventory of hazardous materials used.
3. Requests Material Safety Data Sheet (MSDS) from manufacturer of supplier of each material on inventory. MSDS provides detailed health and safety information, handling procedures, and emergency response procedures.
4. Keep copies of all MSDSs in a central location on site and in appropriate work areas.

5. Develop mechanism to make certain that MSDS file is kept current with changes, additions, and deletions of materials.
6. Label all hazardous material containers. Label should provide enough information so the worker understands the following factors about each material:
 - a. What the material is and its uses
 - b. Degree of health effect (0-4)
 - c. Degree of flammability (0-4)
 - d. Degree of reactivity (0-4)
 - e. Proper PPE wear
 - f. Any special information, such as toxicity, carcinogenicity, etc.
 - g. First aid treatment
7. The National Fire Protection Association's or Paint and Coatings Association's Hazardous Materials Information System can be used for labeling program guidance.
8. Check all incoming material for proper labeling and affix appropriate labels where necessary.
9. Train all exposed employees in the following:
 - a. Safe handling procedures for each material,
 - b. Location of Material Safety Data Sheets (MSDS)
 - c. How to use the MSDS to gather information.
 - d. Understanding labeling information,
 - e. Use and maintenance of required PPE.
10. Document training and refresher training sessions and give written exams to assure participants fully understand subject matter.
11. Train new or transferred employees who will be exposed to hazardous substances.
12. Inform other contractors of hazards of materials present; likewise, have these contractors provide information concerning the hazards of materials that they will be using.

REPORTING OF ACCIDENT/INCIDENT OR DAMAGE

Reporting

All workers must know to report any accident involving injury or property damage, no matter how slight or small. When an employee is injured, the contractor's job foreman or a competent person must initiate appropriate action to seek medical treatment. The Director of Safety and/or the SCA Safety Officer must be immediately notified of any accident/incident by the Contractor's competent site super/job foreman and/or by the SCA Project Officer. The Director of Safety will immediately inform the VP of ERC, VP of Construction Management, the SCA Insurance company and the IG's Office

Accidents Involving Injury and/or Property Damage

The contractor's competent Site Supervisor/Job Foreman or a competent person must

1. Send for appropriate medical personnel and/or public rescue service.

2. Notify the Director of Safety and/or the SCA Safety Officer immediately of any accident/incident.
3. Remove and/or keep back all non-essential personnel.
4. Protect against further damage where possible.
5. Where the possibility of fire, explosion, or electrical injury exists, take additional measures as necessary to protect against any further injury.
6. Make no comments to the media, general public, or all others. Refer all inquiries to the SCA Project Officer.
7. No on-site photographs are to be taken except on approval of the Project Officer.
8. Within immediate area of accident scene, nothing is to be disturbed nor removed after proper evacuation of injured employee. Investigating personnel must be able to inspect the undisturbed scene.
9. Prepare the SCA Job Site Incident Report and within 24 hours of an incident for presentation to the SCA Project Officer.
10. Provide necessary information to the injured worker's employer in order to prepare and submit Form C-2 to the SCA within 24 hours of the incident.

The SCA Project Officer Must

1. Report all accident and incidents as per guidelines outlined herein
2. Notify the Director of Safety and/or the SCA Safety Officer immediately of any accident/incident.
3. Initiate a full investigation and ensure that a Jobsite Incident Report is completed within 24 hours of the accident. The SCA's Insurance is to be notified within 24 hours and an Employer's Report of Work-Related Accident/Occupational Disease (C-2) Exhibit is to be completed and submitted. A copy of the Jobsite Incident Report is to be faxed to the IG's office within 24 hours of any accident or injury.
4. The Jobsite Incident Report shall be completed using the guidelines established in the section entitled: Jobsite Incident Report Format, included herein.
5. Review and sign all accident reports. Ensure that the reports are complete and that the action indicated to prevent a recurrence is adequate and effective.

Fatal Accident Reporting

In the event an employee of a contractor or subcontractor is involved in a construction accident leading to death, or should three or more workers be hospitalized as a result of the same accident, the Occupational Safety & Health Administration is to be notified within 8 hours of accident by calling the local OSHA number or OSHA Hot line at 1-800-321-OSHA.

CLAIM PROCEDURE

In the event of a claim, the following procedures must be strictly adhered to:

Workers' Compensation, Occupational Injury, and Occupational Disease Claims

1. The employer of affected worker will notify the General Contractor and Project Officer immediately.

2. Within 24 hours an Employer's Report Work-Related Accident Form, [C-2](#) will be completed and submitted to attending Insurance Provider.
3. A Notice to Physician should also be completed and the following distributions made:

The original(s) and two (2) copies must be delivered to the General Contractor.

The General Contractor will review the report for accuracy. If forms are not properly completed, they will be returned to the Employer for correction.



Note: It is necessary to include project LLW number on the accident report or form [C-2](#).

4. Mail original(s) and one (1) copy of accurately completed report to:

Liberty Mutual Group
New York, NY 10028 or other firm identified as OCIP Provider by SCA

Fax one copy to the Insurance Broker, Willis at:

Khem Henry
Phone 718-472-8753
Fax – 718-472-8770 or other number identified by SCA

One (1) copy to School Construction Authority Safety Unit.

One (1) copy retained in employer's file.



Note: If the injury is serious or loss time contemplated, a telephone report will immediately be made by the SCA Project Officer to OCIP Provider. The telephone report is to be followed up by written report outlined above.

Following these procedures will result in:

1. Prompt and accurate reporting to OCIP Carrier
2. Prompt notification to SCA Project Officer and SCA Safety Unit of all serious accidents
3. Prompt and thorough accident investigations involving injuries which may later result in third party lawsuits
4. Prompt determination of appropriate Workers' Compensation benefits

General Liability

Reports of personal injuries sustained by anyone including employees (unless C-2 Form completed) or damage to property of others will be completed immediately following occurrence of an accident. All liability claims must be reported to the Employer of the affected worker who, in turn, will report the loss to the School or Construction Authority.

It is essential that all such claims be thoroughly investigated by the SCA Director, the OCIP Provider, and the Contractor's management. All available facts and information, including the names of witnesses, must be secured as soon as possible while such information is still available. Unless prompt action is taken in this respect, witnesses disappear, facts become obscure and the further handling of the claim may be prejudiced.

The Employer of the affected worker will promptly report claims by a telephone call to the liability claims contact at the School Construction Authority. The General Contractor will assist Contractor/Subcontractor in completing General Liability notice.



Attention: Contact same parties as accident/injury above.

The General Contractor will assist in the investigation. However, it shall be the responsibility of the Approved Contractor/Subcontractor to see that all third party injury or property damage claims are thoroughly investigated and promptly reported to the School Construction Authority. Further, the contractor/subcontractor will assist by filing a Jobsite Incident Report with all information provided and any other assistance as required.

Builder's Risk Reporting Procedure

The contractor/subcontractor, upon learning of any occurrence that might possibly give rise to a claim under any of the policies of insurance provided by Owner pertaining to Builder's Risk Insurance (flood, collapse, fire, windstorm), shall give immediate notice to the General Contractor. The General Contractor will report such occurrence to the NYC School Construction Authority's Risk Management Department, Risk Control Manager.



Attention: Contact same parties as accident/injury above.

It is essential that each occurrence be thoroughly investigated by the SCA Safety Director and OCIP Provider.

JOBSITE INCIDENT/ACCIDENT REPORT FORMAT

The Project Officer is to ensure that the Jobsite Incident Report and C-2 form (if required) will be completed within 24 hours of the incident's occurrence. An accurate, detailed narrative description of the operation being performed at the time of the incident is of extreme importance. It is important to remember that a minor miscalculation of movement may have been the generating force that triggered the sequence of events which resulted in the accident.

The Jobsite Incident Report should reveal the following:

1. What happened?
2. When did it happen?
3. Where did it happen?
4. Why did it happen?
5. Who did it happen to?
6. Any eye witnesses?

A sequence of all pertinent facts by the time of their occurrence should be embodied in the report.

1. Time - activity prior to accident
2. Time – occurrence
3. Times - emergency notification of first aid, Project Officer, safety, ambulance, etc
4. Times - arrival at scene of first aid team, ambulance, etc
5. Time - initial treatment or rescue efforts began
6. Time - arrival of ambulance at medical facility, medical treatment, surgery, etc

Distribution of the Jobsite Incident Report

Within 24 hours of the occurrence, the Project Officer will distribute the Jobsite Incident Report, completed by the contractor’s job foreman or the competent person, and C-2 form (if required), completed by the injured worker’s employer, as follows:

	Jobsite Incident Report	C-2 Form
Director, SCA Safety Unit	Original	Copy
SCA Chief Project Officer	Copy	Copy
General Contractor	Copy	Copy
Subcontractor	Copy	Copy
OCIP Insurance Broker	Copy	Original
Office of SCA Inspector General	Copy	Copy
SCA Safety Officer	Copy	Copy

Summary

As soon as possible after notifications are made, a meeting will be held at the worksite of the incident to assure the cause has been determined and proper corrective action has been initiated.

The following personnel will attend this meeting:

1. Contractor’s representative.
2. Contractor’s corporate management and site safety representative.
3. School Construction Authority Safety Director and/or his/her designee.
4. SCA Senior Project Officer and/or SCA Project Officer
5. Pertinent personnel as determined by the SCA Chief Project Officer or his/her designee.

Part 1 Form: Job Site Incident/Accident Form

JOBSITE INCIDENT REPORT

- LOST PROPERTY DAMAGED PROPERTY INJURY FIRE
 SUSPECTED CRIME OR OFFENSE ANY OTHER UNUSUAL OCCURRENCE OR CONDITION (EXPLAIN)

DATE OF REPORT _____

DATE AND TIME OF OCCURRENCE _____

PROJECT AND NUMBER _____

ADDRESS _____

WHERE (DESCRIBE PROPERTY INVOLVED) _____

HOW (Brief Description of Incident. Give Details) _____

NYC POLICE DEPT. RESPONDING NAME _____

PRECINCT _____ SHIELD NUMBER _____

WITNESS NAME _____
 ADDRESS _____
 CITY, STATE _____
 PHONE _____

CONTRACTOR'S NAME _____
 ADDRESS _____
 CITY, STATE _____
 PHONE _____

SUPERVISORS ON SITE _____

PREPARED BY NAME _____
 TITLE _____

SIGNATURE _____ DATE _____

Part 1 Form: C2- New York State Employer's Report of Work- Related Accident/Occupational Disease



EMPLOYER'S REPORT OF WORK-RELATED INJURY/ILLNESS

C-2

State of New York - Workers' Compensation Board

If one of your employees has a work-related injury or illness, you must complete and file this form **within 10 days** of the injury/illness or be subject to a penalty. For additional information on filing this form please refer to Workers' Compensation Law Section 110 at the end of this form. Type or print neatly.

WCB Case Number (if you know it): _____ Date of Injury/Illness: ____/____/____

Carrier Case Number (if you know it): _____ Date of this Report: ____/____/____

A. EMPLOYER INFORMATION

1. Employer: _____ 2. Employer FEIN: _____

3. Mailing Address: _____

4. Location Address (if different): _____

5. Phone Number: (____) _____ 6. Nature of Business or Industry Code: _____

7. OSHA Case Number (if known): _____ 8. NY UI Employer Reg Number: _____

B. INSURANCE CARRIER / SELF-INSURED EMPLOYER

If individually self-insured, enter your Board W Number and skip to Section C.

1. Board W Number: **W** _____ 2. Carrier/Group Name: _____

3. Policy Number: _____ Policy Period: From: ____/____/____ To: ____/____/____

4. If Carrier Unknown, Insurance Agent Name: _____ 5. Phone Number: (____) _____

C. EMPLOYEE'S PERSONAL INFORMATION

1. Name: _____ 2. Date of Birth: ____/____/____
First MI Last

3. Mailing Address: _____

4. Social Security Number: _____ 5. Contact Phone Number: (____) _____ 6. Gender: Male Female

D. EMPLOYEE'S INJURY OR ILLNESS

1. Time of day employee began work on date of injury: _____ AM PM 2. Time of injury: _____ AM PM

3. Has the employee given you notice of injury/illness? Yes No

If yes, notice was given to: _____ orally in writing Date notice provided: ____/____/____

If available, attach a copy of the employee's written notice and medical notes, and the employer's incident report.

4. Have you given the employee a Claimant Information Packet? Yes No If yes, give date: ____/____/____

5. Where did the injury/illness happen (e.g., 1 Main St., Pottersville, at the front door): _____

6. Was this location where the employee normally worked? Yes No If no, why was the employee there? _____

7. Employee's supervisor: _____ 8. Did supervisor see injury happen? Yes No Unknown

9. Did anyone else see the injury happen? Yes No Unknown If yes, give name(s): _____

10. What was the employee doing when he/she was injured or became ill? (e.g., unloading a truck, stocking a shelf, typing annual report)

EMPLOYEE'S NAME: _____ DATE OF INJURY/ILLNESS: ____/____/____
First MI Last

D. EMPLOYEE'S INJURY OR ILLNESS *continued*

11. How did the injury/illness occur? (e.g., the employee tripped over a pipe and fell on the floor) _____

12. Explain fully the nature of the employee's injury/illness; list body parts affected (e.g., twisted left ankle and cut to forehead): _____

13. Was an object (e.g., forklift, hammer, acid) involved in the injury/illness? Yes No If yes, what was it? _____

14. Was the injury the result of the use or operation of a licensed motor vehicle? Yes No
If yes, employee's vehicle employer's vehicle other vehicle License plate number (if known): _____
If employer's vehicle was involved, give name and address of your motor vehicle insurance carrier: _____

15. Did the injury/illness result in the employee's death? Yes No If yes, what was the date of death? ____/____/____
Name and address of the nearest relative: _____

E. MEDICAL TREATMENT

1. What was the date of the employee's first treatment? ____/____/____ None received Unknown
2. Where did the employee receive first medical treatment for this injury/illness? On site Doctor's office Emergency Room
 Clinic/Hospital/Urgent Care Hospital Stay over 24 hours Unknown
Who treated the employee and where? _____

3. Is the employee still being treated for this injury/illness? Yes No Unknown If yes, name and address of treating doctor(s):

4. To your knowledge, did the employee have another work-related injury to the same body part or a similar illness while working for you?
 Yes No If yes, name the doctor(s) who treated the previous injuries/illnesses (if known): _____

F. RETURN TO WORK

1. Did the employee stop work because of his/her injury/illness? Yes No If yes, on what date? ____/____/____
2. Has the employee returned to work? Yes No
If yes, on what date? ____/____/____ regular duty limited duty
3. If the employee has returned to limited duty, what are his/her average gross earnings per week? _____

EMPLOYEE'S NAME: _____ DATE OF INJURY/ILLNESS: ____/____/____
First MI Last

G. EMPLOYEE'S WORK INFORMATION on the date of the injury or illness

- 1. Date the employee was hired: ____/____/____
- 2. What was the employee's job title? _____
- 3. What types of activities did the employee normally perform at work? (Attach job description if available.) _____

H. EMPLOYEE'S PAYROLL INFORMATION on the date of the injury or illness

- 1. Employee's gross pay in an average week was: \$ _____
- 2. Did the employee receive lodging or tips in addition to pay? Yes No If yes, describe: _____

- 3. Employee's job was (check one): Full Time Part Time Seasonal Volunteer Other: _____
- 4. Which days of the week did the employee usually work? Mon. Tues. Wed. Thurs. Fri. Sat. Sun.
- 5. Was the employee paid for a full day on the day of the injury/illness? Yes No
- 6. Did you continue to pay the employee after the injury/illness (e.g., sick leave, vacation, disability, regular salary)? Yes No

I. ADDITIONAL INFORMATION

An employer or carrier, or any employee, agent, or person acting on behalf of an employer or carrier, who KNOWINGLY MAKES A FALSE STATEMENT OR REPRESENTATION as to a material fact in the course of reporting, investigation of, or adjusting a claim for any benefit or payment under this chapter for the purpose of avoiding provision of such payment or benefit SHALL BE GUILTY OF A CRIME AND SUBJECT TO SUBSTANTIAL FINES AND IMPRISONMENT.

The above information is true to the best of my knowledge and belief.

If prepared by the employer:

Signature of Person Preparing Form: _____ Date: ____/____/____

Print Name: _____ Title: _____ Phone Number: (____) _____

If prepared by a Third Party on Behalf of the Employer:

Signature of Person Preparing Form: _____ Date: ____/____/____

Print Name: _____ Title: _____ Phone Number: (____) _____

Company Name and Address: _____

Name & Phone Number of Person Who Provided Information Necessary to Prepare This Form: _____

Reports should be filed by sending directly to the appropriate WCB district office (DO) at the address below with a copy sent to the insurance carrier:

- Albany DO - 100 Broadway-Menands, Albany NY 12241 866-750-5157** (for accidents in the following counties: Albany, Clinton, Columbia, Dutchess, Essex, Franklin, Fulton, Greene, Hamilton, Montgomery, Rensselaer, Saratoga, Schenectady, Schoharie, Ulster, Warren, Washington)
- Binghamton DO - State Office Building, 44 Hawley Street, Binghamton NY 13901 866-802-3604** (for accidents in the following counties: Broome, Chemung, Chenango, Cortland, Delaware, Otsego, Schuyler, Sullivan, Tioga, Tompkins)
- Buffalo DO - Statler Towers, 107 Delaware Avenue, Buffalo NY 14202 866-211-0645** (for accidents in the following counties: Cattaraugus, Chautauqua, Erie, Niagara)
- Rochester DO - 130 Main Street West, Rochester NY 14614 866-211-0644** (for accidents in the following counties: Allegany, Genesee, Livingston, Monroe, Ontario, Orleans, Seneca, Steuben, Wayne, Wyoming, Yates)
- Syracuse DO - 935 James Street, Syracuse NY 13203 866-802-3730** (for accidents in the following counties: Cayuga, Herkimer, Jefferson, Lewis, Madison, Oneida, Onondaga, Oswego, St. Lawrence)
- Downstate Centralized Mailing - PO Box 5205, Binghamton NY, 13902-5205 for all DO's in NYC 800-877-1373; in Hempstead 866-805-3630; in Hauppauge 866-681-5354; in Peekskill 866-746-0552** (for accidents in the following counties: Bronx, Kings, Nassau, New York, Orange, Putnam, Queens, Richmond, Rockland, Suffolk, Westchester)

WORKERS' COMPENSATION LAW

Section 13 Treatment and care of injured employees

(a) "The employer shall promptly provide for an injured employee such medical, surgical, optometric or other attendance or treatment, nurse and hospital service, medicine, optometric services, crutches, eye-glasses, false teeth, artificial eyes, orthotics, functional assistive and adaptive devices and apparatus for such period as the nature of injury or the process of recovery may require. ****"

Section 13 Injury to employee's prosthesis

(a) "Damage to or loss of a prosthetic device shall be deemed an injury except that no disability benefits shall be payable with respect to such injury under section fifteen of this article. ****"

Section 25 Effect of failure to file reports

3. (e) "If the employer or its insurance carrier fails to file a notice or report requested or required by the board or chair or otherwise required within the specified time period or within ten days if no time period is specified, the board may impose a penalty in the amount of fifty dollars. ****"

Section 51 Posting of notice regarding compensation

"Every employer who has complied with section fifty of this chapter shall post and maintain in a conspicuous place or places in and about his place or places of business typewritten or printed notices in form prescribed by the chairman, stating the fact that he has complied with all the rules and regulations of the chairman and the board and that he has secured the payment of compensation to his employees and their dependents in accordance with the provisions of this chapter, but failure to post such notice as herein provided shall not in any way affect the exclusiveness of the remedy provided for by section eleven of this chapter. ****"

Section 52 Effect of failure to secure compensation

1. (a) "Failure to secure the payment of compensation shall constitute a misdemeanor, punishable by a fine of not less than five hundred nor more than two thousand five hundred dollars or imprisonment for not more than one year, or both.

(b) Where any person has previously been convicted of a failure to secure the payment of compensation within the preceding five years, upon conviction for a second violation such person shall be fined not less than one thousand nor more than five thousand dollars in addition to any other penalties including fines otherwise provided by law, and upon conviction for a third or subsequent violation such person may be fined up to seven thousand five hundred dollars in addition to any other penalties including fines otherwise provided by law.

(c) Where the employer is a corporation, the president, secretary and treasurer thereof shall be liable for failure to secure the payment of compensation under this section. ****"

Section 110 Record and report of injuries by employers

1. An employer, or a third party designated by the employer, shall record any injury or illness incurred by one of its employees in the course of employment using the form prescribed by the chair for reporting injuries under subdivision two of this section. Such form, a copy of which shall be provided to the injured employee upon request, shall be maintained by the employer, or a third party designated by the employer, for at least eighteen years, and shall be subject to review by the chair at any time. Such form need not be filed with the chair unless the status of such injury or illness changes resulting in a loss of time from regular duties or in medical treatment which would require reporting in accordance with subdivision two of this section.

2. An employer, or a third party designated by the employer, shall file with the chair of the workers' compensation board and with the carrier if the employer is insured, upon a form prescribed by the chair, a report of any accident resulting in personal injury which has caused or will cause a loss of time from regular duties of one day beyond the working day or shift on which the accident occurred, or which has required or will require medical treatment beyond ordinary first aid or more than two treatments by a person rendering first aid. Such report shall state the name and nature of the business of the employer, the location of its establishment or place of work, the name, address and occupation of the injured employee, the time, nature and cause of the injury and such other information as may be required by the chair. Such report shall be filed within ten days after the occurrence of the accident. An employer shall furnish a report of an occupational disease incurred by an employee in the course of his or her employment, to the chair of the workers' compensation board, and to the carrier if the employer is insured, upon the same form. The carrier, within fourteen days of receipt of the report or accompanying the initial check forwarded to the employee, whichever is earlier, or a self-insured employer, within fourteen days of transmitting the report to the chair or accompanying the initial check forwarded to the employee, whichever is earlier, shall provide the injured employee or, in the case of death, his or her dependents with a written statement of their rights under this chapter, in a form prescribed by the chair. An employer shall file a report of any other accident resulting in personal injury incurred by its employee in the course of employment, upon the same form, whenever directed by the chair.

3. Any injury or illness which is not required to be reported in accordance with subdivision two of this section, shall not be used as a basis for determining experience modification rates, provided the employer pays in the first instance or reimburses the employer's insurer for the treatment rendered to the employee.

4. An employer who refuses or neglects to make a report or to keep records as required by this section shall be guilty of a misdemeanor, punishable by a fine of not more than one thousand dollars. The board or chair may impose a penalty of not more than two thousand five hundred dollars upon an employer who refuses or neglects to make such report.

5. The chair shall be authorized to promulgate regulations necessary to carry out the provisions of this section.

Instructions for Completing Form C-2, "Employer's Report of Work-Related Injury/Illness"

Please complete this form and send it directly to your local Workers' Compensation Board district office (DO). The addresses are listed at the bottom of page 3. Also send a copy of the form to your insurance carrier. If you need additional help in completing this form, you may contact the Workers' Compensation Board at 1-877-632-4996 or visit <http://www.wcb.state.ny.us/>.

If you do not have or know your Workers' Compensation Board Case Number, please leave this field blank. It is not required to process the form. Fill out the Date of Injury/Illness, to the best of your knowledge, and the Date of this Report at the top of page 1. Remember to enter in the name of the injured employee and the date of injury/illness on the top of page 2 and page 3.

Section A - Employer Information:

- Item 1:** Indicate the name of the company or the owner's name and DBA name.
- Item 2:** Enter the employer's Federal Employer Identification Number (FEIN). This is your Federal Tax ID number. If you do not have a FEIN, enter your Social Security Number.
- Item 3:** Enter the employer's main address where you receive mail (such as a central office). Include P.O. Boxes.
- Item 4:** Enter the physical address of the employer (if different).
- Item 5:** Enter the primary contact phone number for the employer, including area code.
- Item 6:** Indicate the North American Industry Classification System (NAICS) or Standard Industrial Classification (SIC) Code for your business. If you do not know your NAICS or SIC Code, please indicate the type or nature of business as accurately as possible (e.g., Restaurant, Construction, Retail).
- Item 7:** Enter the OSHA Case Number, if known.
- Item 8:** Enter the first 7 digits of your New York Unemployment Insurance (NY UI) Registration Number (UIER). This is the number used to report to the Department of Labor.

Section B - Insurance Carrier / Self-Insured Employer:

- Item 1:** Indicate the Carrier Code Number (**W** Number) issued by the Workers' Compensation Board. If you do not know the **W** number, contact your insurance carrier. *If you are self-insured, only enter your Carrier Code Number (**W** Number) and skip to Section C.*
- Item 2:** Enter the name of the employer's Workers' Compensation Insurance Carrier or Group Name. If you do not know your insurance carrier, please indicate the employer's Insurance Agent Name for item 4 and the Agent's contact phone number for item 5.
- Item 3:** Enter your Workers' Compensation Insurance Policy Number and indicate the policy effective period for coverage at the time of the injury or illness.
- Item 4:** Insurance Agent Name if the carrier is unknown.
- Item 5:** Insurance Agent phone number, including the area code.

Section C - Employee's Personal Information:

- Item 1:** Indicate the injured employee's full legal name.
- Item 2:** Enter the employee's date of birth.
- Item 3:** Enter the employee's mailing address, including street number, P.O. Box (if applicable), Town or City, State, and Zip Code.
- Item 4:** Indicate the employee's Social Security Number (SSN).
- Item 5:** Enter a contact phone number for the employee, either a home phone number or a cell phone number, including the area code.
- Item 6:** Indicate his/her gender.

Section D - Employee's Injury or Illness:

If this is an illness or occupational disease and an exact date of illness cannot be determined, then skip items 1 and 2.

- Item 1:** Indicate the time of day when the employee began work on the day the injury occurred.
- Item 2:** Enter the time when the injury occurred.
- Item 3:** Check whether the employee has given notice of his/her injury or illness to the employer. If so, enter the date notice was given and if it was orally or in writing. If written notice was given, please attach a copy of the employee's notice as well as any medical notes you may have received. Also attach the [supervisor's] incident report, if available.
- Item 4:** Check whether you gave the employee a Claimant Information Packet and if so, when.
- Item 5:** Indicate the location where the injury/illness occurred, including the address of the building and the physical location in the building where the injury/illness happened.
- Item 6:** Check if this was the employee's normal work location. If it was not, explain why the employee was at this location.
- Item 7:** Enter the name of the employee's direct supervisor.
- Item 8:** Indicate whether the supervisor was a witness to the injury/illness.
- Item 9:** Check if anyone else witnessed the injury/illness and if so, list their name(s).

Section D - Employee's Injury or Illness (cont.):

- Item 10:** Describe in detail what the employee was doing at the time of the injury/illness (e.g., unloading boxes from a truck by hand). This explains the events leading up to the injury.
- Item 11:** Describe in detail how the injury/illness occurred (e.g., the employee was lifting a heavy box off a truck). This should include all people and events involved in the injury/illness.
- Item 12:** Indicate fully the nature and extent of the employee's injury/illness, including all body parts injured. Be as specific as possible (e.g., lumbar gluteal muscle strain resulting from sudden straining).
- Item 13:** Indicate if some object was involved in the accident OTHER THAN a licensed motor vehicle. Other objects may include a tool (e.g., hammer), a chemical (e.g., acid), machinery (e.g., forklift or drill press), etc.
- Item 14:** Indicate if a licensed motor vehicle was involved in the accident. If so, check if the motor vehicle involved was the employee's, the employer's, or that of a third party and include the license plate number (if known). If the employer's vehicle was involved, fill out the automobile liability insurance carrier for the vehicle and their address.
- Item 15:** Check if the injury/illness resulted in the death of the employee and if so, indicate the date of death and the nearest relative of the deceased (if known).

Section E - Medical Treatment:

- Item 1:** If the employee did not receive medical treatment for this injury/illness, check None Received and skip to item 4. Otherwise, enter the date the employee first started treatment for this injury/illness, or check Unknown if you do not know, and complete the rest of this section.
- Item 2:** Check the location where initial medical treatment was administered for this injury/illness and whom was responsible for treatment/care of the employee (e.g., Physician, Nurse, EMT, etc.). Include the name of the person and the facility.
- Item 3:** If the employee is still receiving ongoing treatment for the same injury/illness, check Yes and indicate the name and address of the physician providing treatment; otherwise check No or Unknown.
- Item 4:** If the employee had a similar work-related injury to the same body part or a similar work-related illness while working for the same employer, check Yes and if known, indicate the name and address of the physician whom provided care; otherwise check No.

Section F - Return To Work:

- Item 1:** If the employee has stopped working as a result of the work-related injury/illness, check Yes and indicate on what date he/she stopped working.
- Item 2:** If the employee has since returned to work, check Yes. Also indicate on what date the employee started working again, as well as if the employee has returned to his/her Normal Duties or if the employee is on Limited or Restricted Duty. (If the employee has not returned to his/her full pre-injury or illness work duties, then the employee is on Limited Duty).
- Item 3:** If the employee has returned to work on Limited Duty, enter in his/her average gross earnings per week.

Section G - Employee's Work Information:

- Item 1:** Indicate the date the employee was hired by the employer.
- Item 2:** Enter the employee's current job title.
- Item 3:** Describe the employee's typical work activities or enter the employee's job description. If you need more space, you may attach an official job description or additional pages to completely and accurately describe the employee's work activities.

Section H - Employee's Payroll Information:

- Item 1:** Enter the employee's average gross weekly pay before the injury/illness.
- Item 2:** Check if the employee received any tips or lodging in addition to his/her regular pay and if so, describe them.
- Item 3:** Check the type of job the employee had.
- Item 4:** Check which days of the week the employee usually worked. If the employee did not work a standard work week, please explain in Section I or attach an additional page or work schedule in order to fully explain.
- Item 5:** Check if the employee was paid for a full day's work on the day of the injury/illness.
- Item 6:** Indicate if the employee continued to receive pay after the illness/injury, such as sick leave or disability pay.

Section I - Additional Information:

Enter any additional information that may be relevant to the employee's work-related injury/illness in this section. You can also use this area to further explain other items in this form, such as G-3 or H-4.

Sign Form C-2 on the last page. If the form was filled out by a third-party on behalf of the employer, that person should sign on the second signature line.

Part 1 Form: Contractor Designated Competent Site Supervisor

The New York City School Construction Authority Safety Program & Procedures Manual
CONTRACTOR DESIGNATED COMPETENT SITE SUPERVISOR

This form shall be completed, in its entirety, by the responsible General Contractor, identifying the “Competent Person” that he/she has assigned to the project. Said General Contractor must include appropriate certifications, training documentation or other information specifying why and how said employee meets the requirements of “Competent Person”, as defined by OSHA 29 CFR 1926.32(f)(read below).

This document shall be submitted to the SCA Project Officer and SCA Safety Unit prior to commencing work activities. This form shall also be posted on site.

General Contractor: _____

School Project: _____ Contract #: _____

I have determined, based on the review of OSHA 29 CFR 1926.32(f) (below), that _____ will act as my designated “Competent Person” for the above referenced project. He/she shall be responsible and accountable for the following:

() *Site Safety* For Site Safety, provide NYCDOB Site Safety Manager Lic. No. _____

() *Specific Activity:* _____

Mr./Ms. _____ has my explicit authority to take prompt corrective action(s), as necessary, including stopping the work, to eliminate hazards, at risk conditions, unsafe acts or any other condition that affects the safety or well-being of an employee or the general public and/or the safety of property and/or equipment. He/she will be responsible for representing our company during the weekly safety meeting and shall maintain all records/documentation mandated by Contractor and/or governing codes and standards.

OSHA 29 CFR 1926.32(f): “Competent Person” means one who is capable of identifying existing and predictable hazards in the surroundings or working conditions which are unsanitary, hazardous or dangerous to employees, and who has authorization to take prompt corrective measures to eliminate them.

The following information and/or attached documents(s) support our selection of the above named individual as “Competent Person” at the aforementioned project. (*Note: minimum requirement is OSHA 10-Hour Construction Safety & Health Certificate issued within the last 5 years for all projects less than \$500,000 and OSHA 30-Hour Construction Safety & Health Certificate issued within the last 5 years or 40-Hour DOB Site Safety Manager’s Course for all projects over \$500,000*)

Print Name _____ Company Name _____

Signature _____ Title _____ Date _____

Part 1 Form: Subcontractor Competent Foreman

SUBCONTRACTOR COMPETENT FOREMAN

This form shall be completed, in its entirety, by the responsible Subcontractor supervisor, identifying the “Competent Person” that he/she has assigned to the project. Said Subcontractor must include appropriate certifications, training documentation or other information specifying why and how said employee meets the requirements of “Competent Person”, as defined by OSHA 29 CFR 1926.32(f)(read below).

This document shall be submitted to the General Contractor, SCA Project Officer and SCA Safety Unit prior to commencing work activities.

Subcontractor: _____

School Project: _____ Contract #: _____

I have determined, based on the review of OSHA 29 CFR 1926.32(f) (below), that _____ will act as my designated “Competent Person” for the above referenced project. He/she shall be responsible and accountable for the following:

() *Site Safety* For Site Safety, provide NYCDOB Site Safety Manager Lic. No. _____

() *Specific Activity:* _____

Mr./Ms. _____ has my explicit authority to take prompt corrective action(s), as necessary, including stopping the work, to eliminate hazards, at risk conditions, unsafe acts or any other condition that affects the safety or well-being of an employee or the general public and/or the safety of property and/or equipment. He/she will be responsible for representing our company during the weekly safety meeting and shall maintain all records/documentation mandated by Contractor and/or governing codes and standards.

OSHA 29 CFR 1926.32(f): “Competent Person” means one who is capable of identifying existing and predictable hazards in the surroundings or working conditions which are unsanitary, hazardous or dangerous to employees, and who has authorization to take prompt corrective measures to eliminate them.

The following information and/or attached documents(s) support our selection of the above named individual as “Competent Person” at the aforementioned project. (*Note: minimum requirement is OSHA 10-Hour Construction Safety & Health Certificate issued within the previous 5 years*)

Print Name _____ Company Name _____

Signature _____ Title _____ Date _____

This page left blank.

Part 1 Checklist: Preconstruction Safety

Name :

Date:

Preconstruction Safety Checklist

✓ Approved Site Safety Plan Posted	On the jobsite the Site Safety Plan must reflect all and any site changes such as staging area, trailer locations, material storage locations, any additional gates, location of crane, etc. Deviations must be approved by the designated Safety Officer. Site Safety Plan must contain provisions as per DOB 790-A: All workers will receive a site specific orientation and have certification that all trade workers have completed the 10-Hour OSHA training course within the previous five calendar years.
✓ Competent Site Supervisor Onsite	Required at all times when work is in progress. Minimum 10-Hour OSHA training required. Minimum 30-Hour OSHA training required for all projects over \$500,00. GC to complete the OSHA competent form and submit to the Safety Officer..
✓ Photo I.D. Badges for All Workers	Required for all workers onsite, badges must contain photo, name, address, and telephone, of company. Anyone observed onsite without a badge will be asked to leave jobsite.
✓ Approved Safety Program	Required for General Contractor and all Subcontractors on the job.
✓ Hazard Communication Program and MSDS Sheets Filed	Necessary for any chemicals that may be used on the job. Must be kept in a central location and easily accessible.
✓ Written protocol and procedure for Lead Paint removal	Describes containment and execution of paint removal including PPE to be used.
✓ Proper PPE	Hard hats, long pants, shirts with sleeves are required onsite for all workers without exception. Use of power tools and operations requiring special PPE such as dust masks, safety goggles, gloves, etc, must be provided by the Contractor.
✓ Posted Site Specific Emergency Evacuation Plan	Posted in trailer.
✓ Fire Prevention and protection	Proper and adequate fire fighting equipment must be maintained on site at all times. Any special operations such as hot work and welding requires the use of a fire watch. Existing Standpipe/Siamese connections including sprinkler connection must not be obstructed. GC to follow all necessary protocol in ensuring that the FDNY has unobstructed access to existing fire fighting connections as well as holding areas
✓ Emergency Numbers posted	Nearest hospital, police precinct, and Fire Department's address and phone number posted on site.-
✓ Weekly Safety Meeting Sign in sheets filed	At weekly safety meetings, employees must print name, company, and sign a document that will be held and made easily available
✓ Electrical Grounding Program Followed	Independent GFCI's required on all electrical tools, daily inspection of all power tools, temporary grounded electrical panels must be covered and adequately protected from natural elements such as rain, snow, etc. All temporary electric installed on the project must be certified by licensed electrician that all wiring, receptacles, etc have been grounded and installed per code. A letter stating so must be submitted to the Safety Officer.
✓ OSHA Log 300 Posted	Must be current, maintained, and posted in the construction trailer
✓ Fall Protection Installed	Fall protection required on all walking/working surfaces 6' of more above a lower level. Use of a standard guard rail system, or full body harness with proper tie-off connection required. GC to submit a designed (PE Engineer) tie-back system for Fall protection required in special cases such as sloped roofs, or roofs without parapets, etc. System must be installed per design and inspected by a PE and letter provided to the Safety Officer.

Name :

Date:

Preconstruction Safety Checklist

✓	Scaffolding Guidelines Followed	All supported pipe frame scaffolding 40' high and over must be designed. All users of the scaffold must have the required 4 hour user training certification issued by an approved DOB agency in accordance with Local Law 52. Any modifications, daily maintenance, etc. must be done by a 32 hour trained and certified worker in accordance with Local Law 52. Fall protection (guard rail system, top rail, mid rail and toeboard required on all working/walking platforms). All temporary lighting must be so installed so as not to make any contact with the metal frames of the scaffold. All wiring must be properly insulated and grounded. Licensed electrician to provide letter to Safety Officer. Fire retardant fine mesh debris netting is required on all the scaffolds.
✓	Sidewalk Bridging Guidelines Followed	Sidewalk bridging will be designed by a PE. All bridging to have 45 degree catchalls installed. All gaps in the sidewalk bridge must be properly closed as per SCA sketch drawing –given to the GC. Lighting must be properly grounded and a licensed electrician is to provide letter to the Safety Officer stating that all lighting has been installed as per code and grounded. GC must install the necessary Sidewalk bridge permit on all major thoroughfares and also install the 311 signs. PE sign off required prior to scaffolding installation on top of bridge. Daily maintenance logs must be kept onsite as per DOB regulations
✓	Excavation Guidelines Followed	GC to notify the Call One Center to mark out utilities. GC to also notify DOB 24-48 hrs prior to any excavation. Any excavation 5' and more requires proper shoring plan designed by a PE. GC to install all required fall protection around the opening.
✓	Crane Guidelines Followed	Follow Crane notification procedure, use of NOC form, 48 hour notification required to the Safety Unit prior to crane arrival on site
✓	Hot Work	GC must obtain permit from FDNY for all hot work using oxygen and compressed gases. 48 hr notification required to the Safety Unit prior to hot work activity and safety protocol included herein to be followed.
✓	Daily Inspection Checklist	GC must maintain a daily inspection checklist on the project.
✓	Permits obtained and posted onsite	Required for all necessary work
✓	Temporary fence Guidelines Followed	Must be minimum 8' high and installed with posts driven into the ground. All chainlink fence panels must have top, mid, and bottom rails. Fine mesh Debris netting is to be installed on the fence. Temporary gates must be locked and secured to prevent unauthorized access. GC to install 311 signs.
✓	Daily Housekeeping Performed	Contractor is responsible for daily clean up of jobsite, including but not limited to the following: -Combustible debris such as wooden pallets, cardboard etc. must not be allowed to accumulate -Staging areas and walkways must be maintained free of all trip/fall hazards. -All scaffold walkways and working platforms must be cleaned of all masonry debris due to grinding and pointing activity -Containers must have a cover to prevent debris from flying due to high wind situations.
✓	Necessary Certificates of Fitness - Required for welding and burning operations	Each operator requires a dedicated fire watch possessing a Certificate of Fitness, powder activated tools - certification of training required as well as Certificate of Fitness issued by FDNY for use of powder activated tool is required.
✓	Security provided	Guard to be posted onsite when contractor not working. GC directed to keep main entrance door secured at all times when workers are inside the building to prevent unauthorized entry.
✓	Corporate Health and Safety Program in Place	Required for both General Contractor and all Subcontractors

Name :

Date:

Preconstruction Safety Checklist

✓ Site Specific Fall protection program in place	Site Specific Fall protection program from roofing subcontractor showing building layout and type of fall protection that will be used
✓ Documented training in Fall protection	Required for all workers using Fall protection systems.
✓ All workers have 4 hour Scaffolding Training	Local Law 52 – 4 hour user certification required for all workers who will be using the supported pipe frame scaffold.
✓ Tar kettle guidelines followed	Need citywide permit from FDNY, Certificate of fitness for operator and fire guard, Tar kettle not permitted on roof, propane storage not permitted overnight. If tanker is being used, area to be barricaded, flagmen to be used to direct pedestrian and vehicular traffic.
✓ Roof vents/exhausts sealed	Required to prevent fumes from entering the building.
✓ CD-5 from DOB required for Roof Hoist	Roof hoist – requires a CD-5 from DOB. Any other hoisting equipment must be installed and operated as per manufacturer's specifications.
✓ Truck Crane documentation prepared	If a truck crane is to be used to hoist material, all required documentation such as CD-4, operator's license, PE letter, etc. must be provided prior to crane arriving onsite.
✓ Roofing Work	All the safety documentation must be submitted prior to start of roof work. Follow safety protocol outlined in SCA Safety Manual
✓ 500-002-SOP reviewed and discussed	Construction Site Accident/Emergency Management
Noise Code	Contractor to have a noise mitigation plan available for review as required by NYC DEP
Suspended Scaffolds	All required training, permits must be obtained prior to use
Pre-Steel Erection meeting	Prior to steel erection, a pre-steel erection meeting will be held by Safety unit
✓ Comply with Safety Recommendations	Immediate compliance with all developed safety recommendations is encouraged and will be noted in the safety report, 24 hr compliance required from receipt of safety report with all sidewalk and scaffolding violations and 48hr for all others.
✓ SCA safety goals enforced	Protection of the school population and general public from all construction hazards must be top priority of the General Contractor.

Part 1 Checklist: Safety Unit Pocket Guide



SCA SAFETY UNIT POCKET GUIDE

PRIOR TO COMMENCEMENT

- **Submit Site Safety Plan for approval**
- **Notify assigned SCA Safety Officer when:**
 - The Site Safety Plan has been approved for projects that include any of the following: Scaffolds; Hoists; Cranes; Debris Chutes
 - The following Meetings are scheduled:
 - Pre-Construction Meeting
 - UFT Protocol Meeting
 - Special Condition Meeting

UPON MOBILIZATION

▫ **Items to be available on site:**

▫ Approved Site Safety Plan	▫ Emergency Phone Numbers
▫ Contractor's Hazard Communication Program	▫ Site Specific Emergency Evacuation Plan
▫ Contractor's Safety Program	▫ OSHA 300 Log
▫ OSHA Poster	▫ Training Documentation Reqd. OSHA 10 hr Training
▫ First Aid Kit	▫ All permits (DOB, DOT, DEP) & sealed Drawings

COMMENCEMENT OF GROUND LEVEL PERIMETER PROTECTION

- **Request SCA Safety Inspection when:**
 - Installation of sidewalk bridge is complete – including inspection by PE (permittee).
 - **NOTE:** Overhead work activity may proceed **ONLY** when ground level perimeter protection is installed in accordance with approved Site Safety Plan.

COMMENCEMENT OF CONTRACT WORK

- **Pre-Construction Meeting to be held prior to start of any of the following:**
 - **Scaffold Installation** – Training records, Permits, Site Safety Plan, Request SCA Safety & PE Inspections.
 - **Installation of trench/excavation protective system** – request SCA Safety & PE Inspection.
 - **Crane arrival** – Request Operator's Information, CD-4, On-Site Inspections, Waivers, etc.
 - **Roofing/ Hot Work** – Kettle Inspection, permits for Storage & Use, Certificate of Fitness, Fire Watch, Hot Work Permit - Welding / Burning.
 - **Demolition** – Roof survey, permits from DOB, dust control plan, fall protection program.
 - **Steel Erection** – Site layout plan, training records, fall protection program.

SAFETY INSPECTION

- **Contractor compliance with safety observations within 24 hours.**
- **Project Officer to verify and confirm to Safety Unit.**
- **Stop Work Order (SWO) observations to be corrected a.s.a.p.**
- **Project Officer to contact Safety Officer to secure SWO release.**

SAFETY INSPECTION CHECKLIST

LADDERS	TOOLS
PROPERLY SECURED	POWER CORDS
EXTEND-36" ABOVE LANDING	PROPER GROUNDING
GOOD CONDITION	MECHANICAL SAFEGUARDS
RIGHT LADDER FOR THE JOB	RIGHT TOOL FOR JOB
SUPPORTED SCAFFOLD	POWDER ACTUATED TOOLS
CONNECTIONS SECURE / CROSS BRACE	FDNY COF
TIED INTO STRUCTURE	QUALIFIED OPERATOR
CLEAN FREE OF DEBRIS	SAFETY GOGGLES
GUARD RAILS, TOEBOARDS	MASONRY
CROSS BRACED	PROPER PPE
NYCDOB 32 hrs CARD FOR ERECTOR / MODIFIER	HOISTS, CRANES
NYCDOB 4 hrs CARD FOR USER	CD-4
SIDEWALK BRIDGING	CABLES O.K.
ADEQUATE LIGHTING / SEC LETTER	TAG LINE USED
PADDING NUTS AND BOLTS	SAFE OPERATION
CATCH ALLS	FLAGMEN & BARRICADES
GUARD RAILS	OPERATORS LICENSE
TOP, MID RAIL, TOEBOARD	GASES / WELDING / PROPANE
CABLES TAUT-200lb PRESSURE	FDNY STORAGE AND USE PERMIT
ELEVATORS SHAFTS / STAIRS	PROPER STORAGE ENCLOSURE
FALL PROTECTION IN PLACE	CERTIFICATE OF FITNESS-USERS & FIRE GUARDS
ADEQUATE SIGNS AND LIGHTING	GRINDING SCREEN / BLANKETS
TEMPORARY RAILING AT STAIRS	PROPER PPE
UNPOURED PANS FILLED	SECURED / CAPPED CYLINDERS
OPENING PROTECTION	SUSPENDED SCAFFOLD
ALL OPENINGS COVERED	CD-5
COVERINGS SECURED AND MARKED	DOB -TRAINING CARDS
GUARD RAILS IN PLACE	DAILY LOG
GENERAL SAFETY	RIGGING FOREMAN CARD
SAFETY / TOOL BOX MEETINGS	PE LETTER-PARAPETS
REQD. OSHA 10 HRS. TRAINING	TIE BACK & LIFELINES
EMERGENCY NOS. POSTED	PROPER COUNTERWEIGHTS SECURED
OSHA POSTINGS	DOB CONFIRMATION NUMBER
WORK PERMITS	ELECTRICAL
SCAFFOLD DRAWINGS	EXTENSION CORDS - OK
SITE SAFETY PLANS	TEMPORARY PANEL PROTECTION
HOUSEKEEPING	GFCI IN USE
CLEANLINESS	EXPOSED WIRING TO BE PROTECTED
COMBUSTIBLE DEBRIS	FIRE PROTECTION
DUST CONTROL	EXTINGUISHERS
SLIP, TRIP AND FALL HAZARD	EVACUATION PLAN
NOTIFICATIONS	TEMPORARY HEATING
CRANE ON SITE	FIRE PROTECTION PLAN
CALL BEFORE YOU DIG	FIRE DEPARTMENT EXITS
EXCAVATION	FDNY HOLDING AREA
SHORING DESIGN	TEMPORARY STAND PIPE SYSTEM
DOB NOTIFICATION	NOISE CODE - NYC DEP

Part 2: General Safety & Health Provisions

INTRODUCTION

On School Construction Authority Projects the following General Safety and Health Provisions shall apply as well as Federal OSHA Standards, New York City Department of Building Codes and School Construction Authority Safety Program & Procedures Manual and any other associated governing rules, regulations, procedures and laws shall be adhered to. The most stringent of these standards shall be applicable.



SCA GENERAL REQUIREMENTS

1. On *occupied schools* the Contractor shall provide photo identification (ID) badges for all of their workers (including their Sub-contractors) and ensure that they are prominently worn at all times while on school property.
2. *Occupied School Building/Premise* is to be defined as any building occupied with school children, educational program participants, educational staff or school administrators
3. All workers on SCA Projects must have OSHA 10 Hour training as required and enforced by New York State Department of Labor.
4. The Contractor is to issue hard hats to all of their workers and enforce the use of head protection at all times while on site.
5. Workers are prohibited from wearing the following on a construction site:
 1. Sneakers (including those with steel toe)
 2. Short pants
 3. Sleeveless shirts (tank tops)
 4. Open toed shoes
6. The following documentation shall be available at a minimum and maintained at every construction site in a safety folder and made available for on site review:

a. Approved Site Safety Plan	As Required
b. Safety & Health Program	All Contractors/Subcontractors
c. Hazcom Program	All Contractors
d. MSDS'	Hazardous Substances
e. Emergency Evacuation Plan	Site Specific

- | | |
|---|--|
| f. Fire Prot/Prev Program | Site Specific |
| g. Emergency Numbers Posted | Notify P.O. |
| h. Weekly Project Safety Mtg. Documentation | All Contractors |
| i. Weekly Toolbox Meeting Documentation | All Project Foremen |
| j. OSHA 300 Log | Current & Maintained |
| k. Fall Protection Program | Where applicable. |
| l. Excavation | Cave-in & Fall Protection |
| m. Daily Inspection Checklist | |
| n. All required Permits | After hours, Scaffold, Shed, Work,
CityWide Comp. Gas, etc. |
| o. All required Certificates of Fitness | Welding & Burning, Powder Activated
Tools, FireGuard, Suspended
Scaffold/Hoist operation, etc. |
| p. All required Roof Hoist Permits (CD-5) | Outrigger Beams 2pt Suspension
Scaffold, Riggers License |
| q. All required training | OSHA 10 Hour/Local Law 52 |
7. Contractors are prohibited from working within any *occupied school* during normal school hours. The Contractor is to work during the hours mandated by the contract.
 8. All safety deficiencies are to be corrected immediately. The Project Officer is to verify compliance of safety deficiencies within 24 hours of receipt of Safety Inspection Report.

SPECIAL PROJECTS

Special projects officiated by other agencies (eg. TPL, Out-to-play, Robin Hood, etc) on public schools, SCA Safety considerations shall apply where applicable.

CTF (Capital Task Force) Projects:

For all projects, \$250,000 and under, the following safety considerations shall apply. The Safety Unit to be notified of initial walk-thru of the job between Construction Management and General Contractor. A designated Safety Officer shall attend the meeting. If it is determined by the Safety Officer that a Site Safety Plan is required based on the scope of work, then the General Contractor is to prepare the same and submit for review and approval by the SCA Safety Unit.

In lieu of a Site Safety Plan, the General Contractor is required to submit a written site specific “safe work plan” and present the same for review and approval by the designated Safety Officer, prior to start of work. The “safe work plan” should include but not be limited to the following:

- Brief Job Scope Description
- Protection of Public (School population) – Flagman, barricades, temporary fence, etc
- Construction equipment that will be used – Ladder, manlift, scissor lift, scaffold, etc.
- Safety measures that will be implemented – Site Supervision (Competent Person with OSHA 10-Hr Training), Fall protection, Fire prevention, housekeeping, temporary lighting, etc.
- Receipt of SCA Safety Manual

All other requirements of the SCA Safety Program and Procedures Manual shall apply to these projects.

For all projects above \$250,000, the General Contractor shall comply with all the requirements of the SCA Safety Program and Procedures Manual, including, but not limited to, the submission of a Site Safety Plan to the SCA Safety Unit for review and approval prior to start of work.

JOC (Job Order Contracting)

The Safety Unit to be notified of initial walk-thru of the job between Construction Management and General Contractor. A designated Safety Officer shall attend the meeting. If it is determined by the Safety Officer that a Site Safety Plan is required based on the scope of work, then the General Contractor is to prepare the same and submit for review and approval by the SCA Safety Unit.

JOC Projects require a Site Specific "Safe Work Plan" that should include the following as a minimum:

- Brief Job Scope description
- Equipment that will be used - Ladder, scaffolds, etc.
- Safety measures that will be implemented - Fall protection, housekeeping, temporary lighting, Fire prevention, etc
- Site and protection of school population - Doors leading to construction area to be secured, marked, etc.
- Working hours
- Designated competent Site Super
- Receipt of SCA Safety manual

SAFETY TRAINING AND EDUCATION

1. The employer shall instruct each employee in the recognition and avoidance of unsafe conditions and the regulations applicable to his work environment to control or eliminate any hazards or other exposure to illness or injury. All training is to be documented and is to include the signature of the trainer and trainee.
2. Employees required to handle or use poisons, caustics, and other harmful substances shall be instructed regarding the safe handling and use, and be made aware of the potential hazards, personal hygiene, and personal protective measures required.
3. Employees required to handle or use flammable liquids, gases, or toxic materials shall be instructed in the safe handling and use of these materials and made aware of the specific requirements contained in Subparts D, F, and other applicable subparts of this part.
4. All employees required to enter into confined or enclosed spaces shall be instructed as to the nature of the hazards involved, the necessary precautions to be taken, and in the use of protective and emergency equipment required. The employer shall comply with any specific regulations that apply to work in dangerous or potentially dangerous areas.

FIRST AID AND MEDICAL ATTENTION

First aid services and provisions for medical care shall be made available by the employer for every employee covered by these regulations. OSHA 1926.50 including Appendix A shall apply.

FIRE PROTECTION AND PREVENTION

The contractor shall be responsible for the development and maintenance of an effective fire protection and prevention program at the job site throughout all phases of the construction, repair, alteration, or demolition work in accordance with the current FDNY Inspection Manual. The plan shall incorporate FDNY F.P. Manual, CH.3, ADDENDUM I, Inspection Guide 7” titled “Buildings Under Construction and Demolition” as well as the NYC Fire Code. All required permits for Hot Work shall be obtained prior to work.

HOUSEKEEPING

During the course of construction, alteration, or repairs, form and scrap lumber with protruding nails, and all other debris, shall be kept cleared from work areas, passageways, and stairs, in and around buildings or other structures.

Combustible scrap and debris shall be removed at regular intervals during the course of construction. Safe means shall be provided to facilitate such removal.

Containers shall be provided for the collection and separation of waste, trash, oily and used rags, and other refuse. Containers used for garbage and other oily, flammable, or hazardous wastes, such as caustics, acids, harmful dusts, etc. shall be equipped with covers. Garbage and other waste shall be disposed of at frequent and regular intervals.

ILLUMINATION

Construction areas, aisles, stairs, ramps, runways, corridors, offices, shops, and storage areas where work is in progress shall be lighted with either natural or artificial means, to an illumination intensity equal to or greater than ten foot candles.

SANITATION

Potable Water

Potable water is water which meets the quality standards prescribed in the U.S. Public Health Service Drinking Water Standards, published in 42 CFR part 72, or water which is approved for drinking purposes by the State or local authority having jurisdiction.

1. An adequate supply of potable water shall be provided in all places of employment.
2. Portable containers used to dispense drinking water shall be capable of being tightly closed, and equipped with a tap. Water shall not be dipped from containers.
3. Any container used to distribute drinking water shall be clearly marked as to the nature of its contents and not used for any other purpose.
4. The common drinking cup is prohibited.
5. Where single service cups (to be used but once) are supplied, both a sanitary container for the unused cups and a receptacle for disposing of the used cups shall be provided.

Non-potable Water

1. Outlets for non-potable water, such as water for industrial or firefighting purposes only, shall be identified by signs meeting the requirements of Subpart G of this part, to indicate clearly that the water is unsafe and is not to be used for drinking, washing, or cooking purposes.
2. There shall be no cross-connection, open or potential, between a system furnishing potable water and a system furnishing non-potable water.

Toilets at Construction Jobsites

1. Toilets shall be provided for employees according to the following table:

Toilet Provisions for Workers	
Number of Employees	Number of Toilets
1-19	1
20-199	1 toilet and 1 urinal for every 40 workers
200 or more	1 toilet and 1 urinal for every 50 workers

Table 1: Toilet Provisions for Workers

2. Under temporary field conditions, provisions shall be made to assure not less than one toilet facility is available.
3. Job sites, not provided with a sanitary sewer, shall be provided with chemical toilets unless prohibited by local codes.
4. Any toilet facility shall be located no more than four (4) stories or 60 feet above or below the work location of any person.
5. Where any female is employed on a construction, demolition or excavation job site, separate, clearly marked toilet facilities, equipped with a locking device shall be provided and maintained in a sanitary condition.

Washing Facilities

1. The employer shall provide adequate washing facilities for employees engaged in the application of paints, coating, herbicides, or insecticides, or in other operations where contaminants may be harmful to the employees. Such facilities shall be in near proximity to the worksite and shall be so equipped as to enable employees to remove such substances.
2. "General." Washing facilities shall be maintained in a sanitary condition.
3. Lavatories shall be made available in all places of employment. The requirements of this subdivision do not apply to mobile crews or to normally unattended work locations if employees working at these locations have transportation readily available to nearby washing facilities which meet the other requirements of this paragraph.
4. Each lavatory shall be provided with hot and cold running water, or tepid running water.
5. Hand soap or similar cleansing agents shall be provided.
6. Individual hand towels or sections thereof, of cloth or paper, warm air blowers or clean individual sections of continuous cloth toweling, convenient to the lavatories, shall be provided.

VERMIN CONTROL

Every enclosed workplace shall be so constructed, equipped, and maintained, so far as reasonably practicable, as to prevent the entrance or harborage of rodents, insects, and other vermin. A continuing and effective extermination program shall be instituted where their presence is detected.

CHANGE ROOMS

Whenever employees are required by a particular standard to wear protective clothing because of the possibility of contamination with toxic materials, change rooms equipped with storage facilities for street clothes and separate storage facilities for the protective clothing shall be provided.

PERSONAL PROTECTIVE EQUIPMENT

The employer is responsible for requiring the wearing of appropriate personal protective equipment in all operations where there is an exposure to hazardous conditions or where this part indicates the need for using such equipment to reduce the hazards to the employees.

MEANS OF EGRESS

Means of egress shall be continually maintained free of all obstructions or impediments to full instant use in the case of fire or other emergency.

General

In every building or structure exits shall be so arranged and maintained as to provide free and unobstructed egress from all parts of the building or structure at all times when it is occupied. No lock or fastening to prevent free escape from the inside of any building shall be installed except in mental, penal, or corrective institutions where supervisory personnel is continually on duty and effective provisions are made to remove occupants in case of fire or other emergency.

Exit Marking

Exits shall be marked by a readily visible sign. Access to exits shall be marked by readily visible signs in all cases where the exit or way to reach it is not immediately visible to the occupants.

EMPLOYEE EMERGENCY EVACUATION PLANS

1. "Scope and application." This section applies to all emergency action plans required by a particular OSHA standard. The emergency action plan shall be in writing (except as provided in the last sentence of paragraph (e)(3) of this section) and shall cover those designated actions employers and employees must take to ensure employee safety from fire and other emergencies.
2. "Elements." The following elements, at a minimum, shall be included in the plan:
 1. Emergency escape procedures and emergency escape route assignments;
 2. Procedures to be followed by employees who remain to operate critical plant operations before they evacuate;

3. Procedures to account for all employees after emergency evacuation has been completed;
 4. Rescue and medical duties for those employees who are to perform them;
 5. The preferred means of reporting fires and other emergencies; and
 6. Names or regular job titles of persons or departments who can be contacted for further information or explanation of duties under the plan.
3. If the employee alarm system is used for alerting fire brigade members, or for other purposes, a distinctive signal for each purpose shall be used.
 4. "Evacuation." The employer shall establish in the emergency action plan the types of evacuation to be used in emergency circumstances.
 5. "Training." Before implementing the emergency action plan, the employer shall designate and train a sufficient number of persons to assist in the safe and orderly emergency evacuation of employees.
 6. The employer shall review the plan with each employee covered by the plan at the following times:
 - a. Initially when the plan is developed
 - b. Whenever the employee's responsibilities or designated actions under the plan change
 - c. Whenever the plan is changed.
 7. The employer shall review with each employee upon initial assignment those parts of the plan which the employee must know to protect the employee in the event of an emergency. The written plan shall be kept at the workplace and made available for employee review. For those employers with 10 or fewer employees the plan may be communicated orally to employees and the employer need not maintain a written plan.

NOISE MITIGATION

In accordance with Local Law 113 of 2007, all construction sites shall establish a noise mitigation plan, offer alternatives for contractors to continue their important construction tasks while having less noise impact on the surrounding environment. Noise Mitigation is enforced by NYC DEP.

Part 2 Form: Receipt of Safety Manual for Special Projects

New York City School Construction Authority
3030 Thompson Ave
L.I.C. New York, 11101-3045



Receipt of 2009 Safety Manual

This document recognizes that the below mentioned contractor, and all persons working as employees or subcontractors for the contractor, while working on The New York City School Construction Authority Project referred to as (Contract # or LLW) _____ and taking place at _____, located at _____, New York, has received a complete copy of the New York City School Construction Authority, “ 2009 SCA Safety Manual”.

The contractor and its assignees also, upon receipt of the 2009 SCA Safety Manual, agree to perform all activities and project related activities using the rules and guidelines set forth in this safety manual.

Contractor Name and address

Contractor representative

(Print) _____

(Sign) _____

(Date) _____

Part 3: Concrete & Masonry Construction

INTRODUCTION

On School Construction Authority Projects where concrete & masonry construction is to take place Federal OSHA Standards, current New York City Department of Building Codes, School Construction Authority Safety Program and Procedures Manual and any other associated governing agencies rules, regulations, procedures and laws shall be adhered to and shall be implemented. The most stringent of these standards shall be applicable.

BASIC TERMINOLOGY

- Bull float
- Form Work
- Limited Access Zone
- Pre-cast Concrete
- Re-Shoring
- Shore
- Vertical Slip Forms



SCA GENERAL REQUIREMENTS

Item	Requirement
Construction Loads	No construction loads shall be placed on a concrete structure or portion of a concrete structure unless the employer determines based on information received from a person who is qualified in structural design, that the structure or portion of the structure is capable of supporting the loads.
Reinforcing Steel	All protruding reinforcing steel, onto and into which employees could fall, shall be guarded to eliminate the hazard of impalement.
Post Tensioning Operations	No employee except those determined to be essential shall be permitted to be behind the jack during tensioning operations. Signs and barriers shall be erected to limit employee access to the post tensioning area during tensioning operations.

Item	Requirement
Riding Concrete Buckets	No employee shall be permitted to ride concrete buckets.
Working Under Loads	No employee shall be permitted to work under concrete buckets while buckets are being elevated or lowered into position. To the extent practical, elevated concrete buckets shall be routed so that no employee, or the fewest number of employees, are exposed to the hazards associated with falling concrete buckets.
Personal Protective Equipment	No employee shall be permitted to apply a cement, sand, and water mixture through a pneumatic hose unless the employee is wearing protective head and face equipment.
Bulk Cement Storage	Bulk storage bins, containers, and silos shall be equipped with the following: Conical or tapered bottoms Mechanical or pneumatic means of starting the flow of material No employee shall be permitted to enter storage facilities unless the ejection system has been shut down, locked out, and tagged to indicate that the ejection system is not to be operated.
Concrete Mixers	Concrete mixers with one cubic yard or larger loading skips shall be equipped with the following: A mechanical device to clear the skip of materials Guardrails installed on each side of the skip
Power Concrete Trowels	Powered and rotating type concrete troweling machines that are manually guided shall be equipped with a control switch that will automatically shut off the power whenever the hands of the operator are removed from the equipment handles.
Concrete Buggies	Concrete buggy handles shall not extend beyond the wheels on either side of the buggy.
Concrete Pumping Systems	Concrete pumping systems using discharge pipes shall be provided with pipe supports designed for 100 percent overload. Compressed air hoses used on concrete pumping system shall be provided with positive fail safe joint connectors to prevent separation of sections when pressurized.
Concrete Buckets	Concrete buckets equipped with hydraulic or pneumatic gates shall have positive safety latches or similar safety devices installed to prevent premature or accidental dumping. Concrete buckets shall be designed to prevent concrete from hanging up on top and the sides.
Tremies	Sections of tremies and similar concrete conveyances shall be secured with wire rope (or equivalent materials) in addition to the regular couplings or connections.
Bull Floats	Bull float handles, used where they might contact energized electrical conductors, shall be constructed of nonconductive material or insulated with nonconductive sheath whose electrical and mechanical characteristics provide the equivalent protection of a handle constructed of nonconductive material.
Masonry Saws	Masonry saws shall be guarded with semicircular enclosure over the blade.

Item	Requirement
	A method for retaining blade fragments shall be incorporated in the design of the semicircular enclosure.

LOCKOUT AND TAGOUT PROCEDURES

No employee shall be permitted to perform maintenance or repair activity on equipment (such as compressors, mixers, screens or pumps used for concrete and masonry construction activities) where the inadvertent operation of the equipment could occur and cause injury, unless all potentially hazardous energy sources have been locked out and tagged.

Tags shall read **Do Not Start** or similar language to indicate that the equipment is not to be operated.

Only the employee performing the maintenance or repair activity or the immediate foreman is permitted to have the keys for the lock out device.

REQUIREMENTS FOR CAST IN PLACE CONCRETE

General Requirements for Formwork

1. Formwork shall be designed, fabricated, erected, supported, braced and maintained so that it will be capable of supporting without failure all vertical and lateral loads that may reasonable be anticipated to be applied to the formwork. Formwork, which is designed, fabricated, erected, supported, braced and maintained in conformance with the Appendix to this section, will be deemed to meet the requirements of the paragraph.
2. Drawings or plans, including all revisions, for the jack layout, formwork (including shoring equipment), working decks, and scaffolds, shall be available at the jobsite.

Shoring and Re-Shoring

1. All shoring equipment (including equipment used in reshoring operations) shall be inspected prior to erection to determine that the equipment meets the requirements specified in the formwork drawings.
2. Shoring equipment found to be damaged such that its strength is reduced to less than that of the requirement in #1 of General Requirements for Formwork, shall not be used for shoring.
3. Erected shoring equipment shall be inspected immediately prior to, during, and immediately after concrete placement.
4. Shoring equipment that is found to be damaged or weakened after erection, such that its strength is reduced to less than that required by General Requirements for Formwork, shall be immediately reinforced.
5. The sills for shoring shall be sound, rigid, and capable of carrying the maximum intended load.
6. All base plates, shore heads, extension devices, and adjustment screws shall be in firm contact, and secured when necessary, with the foundation and the form.
7. Eccentric loads on shore heads and similar members shall be prohibited unless these members have been designed for such loading.
8. Whenever single post shores are used one on top of another (tiered), the employer shall comply with the following specific requirements in addition to the general requirements for formwork;

- a. The design of the shoring shall be prepared by a qualified Engineer and the erected shoring shall be inspected by the Engineer of Record.
 - b. The single post shores shall be vertically aligned.
 - c. The single post shores shall be spliced to prevent misalignment.
 - d. The single post shores shall be adequately braced in two mutually perpendicular directions at the splice level. Each tier shall also be diagonally braced in the same two directions.
9. Adjustment of single post shores to raise formwork shall not be made after the placement of concrete.
 10. Re-shoring shall be erected, as the original forms and shores are removed, whenever the concrete is required to support loads in excess of its capacity.
 11. Re shores of wood or metal shall be screw adjusted or jacked and locked or wedged. Wedges shall not be used within ten feet of the façade. Re shores shall not be jacked or screwed so tight that they pre load the floor below or remove the normal deflection of the slab above. Re shores within ten feet (10') of the faced shall be secured.

Vertical Slip Forms

1. The steel rods or pipes on which jacks climb or by which the forms are lifted shall be:
 - a. Specifically designed for that purpose
 - b. Adequately braced where not encased in concrete
2. Forms shall be designed to prevent excessive distortion of the structure during the jacking operation.
3. All vertical slip forms shall be provided with scaffolds or work platforms where employees are required to work or pass.
4. Jacks and vertical supports shall be positioned in such a manner that the loads do not exceed the rated capacity of the jacks.
5. The jacks or other lifting devices shall be provided with mechanical dogs or other automatic holding devices to support the slip forms whenever failure of the power supply or lifting mechanism occurs.
6. The form structure shall be maintained within all design tolerances specified for plumbness during the jacking operation.
7. The predetermined safe rate of lift shall not be exceeded.

REINFORCING STEEL

Reinforcing steel for walls, piers, columns, and similar vertical structures shall be adequately supported to prevent overturning and to prevent collapse.

Employers shall take measure to prevent unrolled wire mesh from recoiling. Such measures may include, but are not limited to, securing each end of the roll or turning over the roll.

REMOVAL OF FORMWORK

Forms and shores (except those used for slabs on grade and slip forms) shall not be removed until the employer determines that the concrete has gained sufficient strength to support its weight and superimposed loads. Such determination shall be based on compliance with one of the following:

1. The plans and specifications stipulate conditions for removal of forms and shores, and such conditions have been followed.
2. The concrete has been properly tested with an appropriate ASTM standard test method designed to indicate the concrete compressive strength, and the test results indicate that the concrete has gained sufficient strength to support its weight and superimposed loads.

Re-shoring shall not be removed until the concrete being supported has attained adequate strength to support its weight and all loads in place upon it.

Precautions must be taken during form stripping and removal to prevent pieces of the form work from falling onto work or public areas below.

REQUIREMENTS FOR PRE-CAST CONCRETE

1. Pre-cast concrete wall units, structural framing, and tilt up wall panels shall be adequately supported to prevent overturning and to prevent collapse until permanent connections are completed
2. Lifting inserts, which are embedded or otherwise, attached to tilt up pre-cast concrete members shall be capable of supporting at least two times the maximum intended load applied or transmitted to them
3. Lifting inserts which are embedded or otherwise attached to pre-cast concrete members, other than the tilt up members, shall be capable of supporting at least four times the maximum intended load applied or transmitted to them
4. Lifting hardware shall be capable of supporting at least five times the maximum intended load applied or transmitted to the lifting hardware
5. No employee shall be permitted under pre-cast concrete members being lifted or tilted into position except those employees required for the erection of those members

REQUIREMENTS FOR MASONRY CONSTRUCTION

1. A limited access zone shall be established whenever a masonry wall is being constructed. The limited access zone shall conform to the following:
 - a. Established prior to the start of construction of the wall
 - b. Equal to the height of the wall to be constructed plus four feet, and shall run the entire length of the wall
 - c. Established on the side of the wall which will be un-scaffolded
 - d. Re-restricted to entry by employees actively engaged in constructing the wall. No other employees shall be permitted to enter the zone.
 - e. Remain in place until the wall is adequately supported to prevent overturning and to prevent collapse unless the height of wall is over eight feet, in which case, the limited

access zone shall remain in place until the requirements of the following paragraph #2 of this section have been met.

2. All masonry walls over eight feet in height shall be adequately braced to prevent overturning and to prevent collapse unless the wall is adequately supported so that it will not overturn or collapse. The bracing shall remain in place until permanent supporting elements of the structure are in place.

Part 4: Confined Space Entry

INTRODUCTION

On School Construction Authority Projects where entry into a Confined Space or a Permit Required Confined Space is to take place, Federal OSHA Standards, New York City Department of Building Codes and School Construction Authority and any other associated governing agencies rules, regulations, procedures and laws shall be adhered to and shall be implemented. The most stringent of these standards shall be applicable.

BASIC TERMINOLOGY

Definitions for the following terms are listed alphabetically within the Glossary located at the back of this publication.

- Confined Space Entry
- Confined Space
- Permit Required Confined Space



SCA GENERAL REQUIREMENTS

1. All persons involved in working in Confined Spaces, as defined in OSHA 1926.21(b)(6)(iii), shall be trained and documentation of current training shall be provided.
2. A written Site Specific Confined Space Entry Procedure shall be provided for Confined Space and Permit Required Confined Space as applicable.
3. All training records and procedures shall be readily available on site for review.

PURPOSE

The purpose of this procedure is to provide the necessary guidelines and tools to protect employees that are required to perform maintenance, cleaning, or other types of work within confined spaces.

RESPONSIBILITY

The supervisor that is responsible for the area where the confined space is located is the person that is responsible for the implementation of the procedures outlined in this program. The following are the

general procedures that outline the requirements for successfully completing confined space entry work, but it does not give specific details on how to handle every given space. It is the responsibility of the supervisor to understand all the stipulations necessary to successfully meet all of the requirements set forth by OSHA / NYC DOB / SCA and the location, as well as, keep the people involved in the confined space work free from any recognized hazard.

REQUIREMENTS

Entry into any confined space will only be allowed if all the necessary precautions have been taken to ensure the area is free from any recognized hazard, that all OSHA / NYC DOB / SCA regulations are being followed and met, and that the guidelines set forth in this program are adhered to. See Appendix A: Permit Required Confined Space Decision Flow Chart

Identification of Confined Spaces

All confined spaces must be identified and labeled according to OSHA / NYC DOB / SCA standards. Remember, that just because one does not intend to enter a confined space does not mean that it is not a confined space. All confined spaces must be identified and labeled even if entry into the space is unlikely. The signage shall state the following **“Danger ~ Confined Space, Do Not Enter”** or **“Danger ~ Permit-Required Confined Space, Do Not Enter”**. Supervisors who are responsible for the work area where the confined spaces are located will be responsible for communicating the dangers associated with unauthorized entry into the space. Authorized employees will be trained to enable them to enter into the spaces in a safe and healthful mannerism. Sewers, pits, and manholes are always deemed as confined spaces and are not necessary to label.

Finally, remember that confined spaces include, but are not limited to, all sewers, pits, vaults, tanks, vessels, storage bins, hoppers, tunnels, duct work that:

1. Are large enough to enter
2. Have a limited or restricted means for entry
3. Are not designed for continuous occupancy
4. Have, or have the potential for, hazardous atmospheres or other recognized safety and/or health hazards
5. Contain the potential for engulfment by particulate matter by a liquid or solid

Entry Requirements for Confined Spaces

NYCSCA personnel and authorized contractors will only enter into confined spaces if the following strict requirements are met and followed:

1. Make sure that measures have been taken to ensure that unauthorized entry does not occur.
2. The “Confined Space Entry Procedure Worksheet” has been completed. See Appendix B
3. Develop and implement safe procedures and practices necessary to perform the assigned task in a safe and healthful way while working within the confined space. Upon completion of the permit or procedures, prior to entry, the permit or procedures must be approved and signed off by the Supervisor.
4. Specify and document what acceptable entry conditions are.
5. Isolate the space to eliminate as many hazards as possible before removing confined space covers.

6. Purge, inert, flush, or vent the space to eliminate or control atmospheric hazards before removing the covers.
7. When the entrance covers are removed, the openings shall be promptly guarded to protect entrants from external hazards and accidental fall through.
8. Before anyone is allowed to enter the space, atmospheric testing must be performed from outside the space. Continuous monitoring is also required throughout the duration of the entry. The following items must be tested for prior to entry and throughout the entry with a calibrated direct reading instrument:
 1. Oxygen
 2. Combustible Gases
 3. Carbon Monoxide
 4. Any other potential toxic air contaminant that is likely to be within the space



Warning! Hazardous atmospheres must be eliminated prior to any employee's entry into the space.

9. Continuous forced-air ventilation shall be used according to the following guidelines:
 1. Forced-air ventilation can not be used as a means for controlling a hazardous atmosphere, it must be used as a means for eliminating residual hazardous atmospheres that exist in the space;
 2. The ventilation system will be directed to ventilate the space for the duration of the permit; and
 3. The air supply for the ventilation must come from a clean source and may not increase the hazards within the space during the entry.
10. If a hazardous atmosphere is detected during entry, the following must occur:
 1. All employees must leave the space immediately;
 2. The space shall be evaluated to determine the source causing the hazardous atmosphere; and
 3. Measures shall be taken to protect employees from the hazardous atmosphere before any subsequent entry takes place.

Acceptable Atmospheric Conditions Prior to Entry

Entry into any confined space is acceptable only if the following atmospheric conditions are met:

1. Flammable gas, vapor, or mist is less than 10% of its lower explosive limit (LEL);
2. Airborne combustible dust concentrations are less than 10% of its LEL (this condition may be approximated as a condition in which the dust obscures vision at distance of five feet or less);
3. Atmospheric concentrations of oxygen must be within the range of 19.5% to 23.5%;
4. Atmospheric concentrations of any substance for which a dose or permissible exposure limit (PEL) is published in Subpart G, "Occupational Health and Environmental Control", or in Subpart Z, "Toxic and Hazardous Substances" of 29 CFR 1910 must not be present above the PEL; and
5. No other atmospheric condition that is immediately dangerous to life or health may be present.

ISOLATION

The confined space will be removed from service and completely protected against the release of energy and material into the space.



Example: Methods to accomplish isolation of the confined space include, but are not limited to, “blanking or blinding”; “misaligning”; “line breaking”; using a “double block-and-bleed system”; assuring “lockout/tagout of all energy sources”; or “blocking or disconnecting all mechanical linkages.”

PURGING, INERTING, FLUSHING, OR VENTILATING

The methodology that shall be used to ensure that a safe atmosphere exists within the confined space before any authorized entrant may enter the space is as follows:

1. The exhaust system of the ventilation system shall be configured in such a way to prevent hazardous atmosphere exposures to those employees in or about the space that is to be entered;
2. If there is a potential for a flammable atmosphere, all lighting and electrical equipment shall be explosion-proof;
3. Initial testing and continuous monitoring shall be performed while the permit is in effect to ensure that all potential hazardous atmospheres continue to be eliminated; and
4. The ventilation system will be configured in such a way to keep any atmospheric contaminant within the space below its PEL and/or any combustible contaminant below 10% of its LEL.

TESTING

Testing and monitoring must be performed in order to evaluate the conditions within the space where entry is to be performed.

Testing will be performed with a properly calibrated instrument in the following way:

1. Entry conditions will be tested to determine if acceptable conditions exist before the entry is authorized to begin. The following must be tested for:
 1. Oxygen
 2. Combustible Gases
 3. Carbon Monoxide
 4. Any other potential toxic air contaminant that is likely to be within the space
2. Continuous monitoring is required for the above listed items for the duration of the entry or until the permit is canceled;
3. Oxygen will always be tested first, followed by testing for combustible gases and vapors, and finally, testing for toxic gases and vapors.

PERMIT SYSTEM

1. The permit will be designed and signed-off by the confined space competent person for the area where the entry is to take place.
2. The supervisor directly responsible for the work activity will then review the permit.
3. Finally, the supervisor directly overseeing all of the activities within the area where the entry is to take place will approve the permit.
4. Prior to entry, the entry supervisor that is designated on the permit shall sign the permit for authorized entry once all the hazard elimination steps have been performed.
5. The signed permit will be posted, at the entry location, at the time entry into the space is to begin.
6. The duration of the permit shall not exceed the time required to complete the assigned task.
7. The entry supervisor shall terminate the entry or cancel the permit when the following occurs:
 - a. The work in the space has been completed
 - b. A condition not allowed under the permit occurs
8. Once the permit is canceled, it shall be forwarded to the supervisor for record retention and a copy to the Safety Manager for filing purposes. The permits shall be retained for three years after the completion of the entry.

TRAINING

1. All **Authorized Entrants** and **Attendants** that are assigned to work in confined spaces shall be trained prior to any confined space job assignment is issued. These employees shall be trained:
 1. Before any assignment to confined space work,
 2. Whenever there is a change to the assigned confined space duties, and
 3. Whenever there is a change in the permit that results in newly recognized hazards.
2. Additional training shall be required if there is belief that there is a deviation from the procedures outlined in the permit, or if inadequacies in the employee's knowledge of these procedures are noted.
3. **Entrant** training shall include, but not be limited to:
 1. Hazard Recognition
 2. Communication
 3. Personal Protective Equipment
 4. Lockout/Tagout
 5. Respiratory Protection
 6. Self-Rescue
 7. Permitting
4. In addition to the above listed training elements, the **Attendants** must be trained in the following:
 1. Tracking the Number of Entrants
 2. Effects of Hazard Exposure
 3. Monitoring Multiple Spaces
 4. Emergency Procedures
 5. Rescue Procedures

DUTIES

Duties of an Entrant

1. Know the hazards that may be faced during entry, including information on the mode, signs or symptoms, and consequences of the exposure.
2. Know the proper use of equipment provided for entry operation.
3. Communicate with the attendant as necessary to enable the attendant to monitor entrant status and to enable the attendant to alert entrants of the need to evacuate the space.
4. Alert the attendant whenever:
 - a. The entrant recognizes any warning sign or symptoms of exposure to a dangerous situation
 - b. The entrant detects a prohibited condition
5. Exit for the space as quickly as possible whenever:
 1. An order to evacuate is given by the attendant or entry supervisor
 2. The entrant recognizes any warning signs or symptoms of exposure to a dangerous situation
 3. The entrant detects a prohibited condition
 4. An evacuation alarm is activated

Duties of Attendants

1. Know the hazards that may be encountered during entry, including information on the mode of entry, signs or symptoms, and consequences of exposure.
2. Is aware of possible behavioral effects of hazard exposure in authorized entrants.
3. Continuously maintains an accurate count of authorized entrants in the space and ensures that only authorized entrants are in the space.
4. Communicates with authorized entrants as necessary to monitor entrant status and to alert entrants of the need to evacuate the space.
5. Monitors activities inside and outside the space to determine if it is safe for entrants to remain in the space and orders the authorized entrants to evacuate the space immediately under any of the following conditions:
 1. If the attendant detects prohibited conditions;
 2. If the attendant detects the behavioral effects of hazard exposure in an authorized entrant;
 3. If the attendant detects a situation outside the space that could endanger the authorized entrants; or
 4. If the attendant cannot safely perform all of his/her assigned duties during the entry operation.
6. Summons rescue and other emergency services as soon as determination is made that authorized entrants may need assistance to escape from the hazards.
7. Takes the following actions when unauthorized persons approach or enter the space while entry is under way:
 1. Warns unauthorized persons to stay away from the space;

2. Advises unauthorized persons that they must exit immediately if they have entered the space; and
3. Informs authorized entrants and the entry supervisor if unauthorized persons have entered the space.
8. Performs non-entry rescues.
9. The attendant may perform no duties which will interfere with his/her primary duty to monitor and protect the authorized entrants.

Duties of Entry Supervisor

1. Knows the hazards that may be encountered during entry, including information on the mode of entry, signs or symptoms, and consequences of exposure.
2. Verifies by checking that the appropriate entries have been made on the permit and that all procedures and equipment specified by the permit are in place before endorsing the permit and allowing the entry to begin.
3. Terminates the entry and cancels the permit.
4. Verifies that rescue services are available and that the means for summoning them are operational.
5. Removes unauthorized individuals who enter or who attempt to enter the space during entry operations; and
6. Determines whenever responsibility for the space entry operation is transferred and; at intervals dictated by the hazards and operations performed within the space, that entry operations remain consistent with terms of the permit and that acceptable entry conditions are maintained.

RESCUE AND EMERGENCY SERVICES

Only qualified and trained rescue personnel may enter a space to perform rescue operations. Employees providing such services or participating rescue and emergency service operations shall comply with the following requirements:

1. Each member of the rescue service will be provided with and trained to properly use personal protective equipment and rescue equipment necessary for making rescues from confined spaces.
2. Each member of the rescue service will be trained to perform his/her assigned rescue duties and will also receive the training required for authorized entrants.
3. Each member of the rescue service will practice making space rescues at least once every 12 months by means of simulated rescue operations in which they remove dummies, mannequins, or actual persons from actual spaces or representative spaces.
4. Each member of the rescue service will be trained in basic first aid and CPR. At least one member of the rescue service team will hold a current certification in first aid and in CPR.
5. Each authorized entrant will use a full body harness, with a retrieval line attached at the center of the entrant's back, near shoulder level, or above the entrant's head. Wristlets may be used in lieu of the full body harness if it can be demonstrated that the use of a chest or full body harness is impractical or creates a greater hazard and that the use of wristlets is the safest and most effective alternative.

The other end of the retrieval line will be attached to a mechanical device or fixed point outside the space in such a manner that rescue can begin as soon as the rescuer becomes aware that it is necessary. A mechanical device will be available to retrieve personnel from vertical-type spaces more than five feet deep.

POST ENTRY REVIEW

The Contractor's Safety Department will immediately facilitate a review of specific entry operations under the following circumstances:

1. Unauthorized entry
2. Detection of hazards not addressed on a permit
3. Complaints of the effectiveness of entry procedures

Subsequent entries will not be authorized until the review is completed with all necessary revisions made.

PROGRAM REVIEW

The Contractor's Safety Department will facilitate a Procedure and Program Review at least annually. Canceled permits will be used in revising the program.

Part 4 Form: Confined Space Entry Procedure Worksheet

Confined Space Entry Procedure Worksheet

1. Location

Exact name and location of space to be entered.

2. Hazard Identification & Determination - (circle all that apply)

a. *Tasks to be performed.*

Welding/Cutting	Solvent Cleaning	Dry Sweeping	Painting	Inspection
Grinding	Vacuuming	Scraping	Mechanical Repair	Other (Specify below)

Hazardous Contents: (Materials that were, may still be, or will be in the space). Attach MSDS(s) - (circle all that apply)

Oxygen Deficiency	Natural Gas	Caustics	Hot Air
Carbon Monoxide	Steam	Acids	Epoxy Powder Coat
Hydrogen Sulfide	Water	Cleaning Agents	Other (Specify below)
Combustible Atmosphere	Fuel / Oil	Solvents	

The signs & symptoms of overexposure are: (Use MSDSs - (circle all that apply))

Headache	Light Headedness	Nausea	Giddiness
Stupor	Eye Irritation	Chest Pain	Others: (Specify below)
Dizziness	Throat Irritation	Vomiting	
Fatigue	Nose Irritation	Collapse	

Physical, Entrapment and Engulfment Hazards: (Reference Engineering Drawings) - (circle all that apply)

Fire / Flammable	Falling	Sloping Sides	Soft Material	Moving Agitators
Explosive	Slippery Surfaces	Limited Maneuverability	Open Manhole	Liquids

Other:

3. Pre-Entry Confirmation

Initial Atmospheric Testing (to be completed prior to entry)

Gas / Vapor	Date	Instrument /Detector Tube Type	Date of Calibration/ Expiration	Test Result	Range of Acceptable Concentrations
Oxygen Level					>19.5% & <23.5%
Combustible Gas Vapor					<10% of LEL
Carbon Monoxide					<35 ppm
Hydrogen Sulfide					

Tested by: _____ Date: _____ Acceptable Unacceptable

5. Hazard Elimination Procedures

6. Access Prevention / Warning

Determination that the space is safe to open will be made by: _____

Authorization to open the confined space may be given by: _____

How will the entrance be opened? _____

The entrance will be marked, guarded or secured by: _____

7. Hazard Re-Evaluation

List the materials which require ventilation for dilution or to prevent build-up: _____

List the hazards which have not been eliminated and require further controls: _____

List any remaining entrapment or engulfment hazards: _____

8. Air Contaminate Monitoring Not Required **Required** Attach monitoring log

Periodic monitoring for: _____

Continuous monitoring for _____

Appropriate Monitor Model Numbers _____ Number of meters _____

9. **Hazard Control Requirements**

All entries where the hazard has not been eliminated and those with engulfment or entrapment hazards **require**:

1. Equipment to control the hazards which were not eliminated.
2. Emergency retrieval / rescue equipment.
3. Provisions for a trained Rescue Team.
4. A trained Attendant.

If the hazards have not been eliminated and any one of these four items is not present and functional,

No Entry Can Be Made

10. Equipment

<u>Entry</u>	<u>Retrieval</u>	<u>Personal Protective Equipment</u>		<u>Respirator</u>
Rope	Hoist Tripod	Face Shield	Goggles	Hood
Harness	Ladder	Rain Suit	Boots	Cool Vest
Lanyard	Crane Basket	Coveralls / Disposable		Underclothes
Lifeline	Man lift	Coveralls / Flame Retardant		Duct Tape
Wristletts	Block & Tackle	Work Gloves Type _____		Air Line with Escape Tank
	Controlled Descent	Chemical Gloves Type _____		
<u>First Aid Rescue</u>	<u>Splash</u>	<u>Continuous Mechanical Ventilation</u>		<u>Warning / Barrier</u>
Oxygen Unit	Water Hose	FD Fans	ID Fans	Cones Flashers
Fire Blanket	Portable Eyewash	Air Movers	Portable Fans	Saw Horses
Scott Air Pak	Portable Shower	Portable Blower with Elephant Trunk		Portable rails
Stretcher	Sorbents			"Confined Space" Signs
Water Gel Blanket				"No Entry" Signs

11. Explosion or Fire

Fire Extinguisher Type Dry Chemical CO₂ Is Hot-Work Permit required? Yes No

Number of extinguishers to be at site: _____ Permits _____

Fire Hose. Charged Spark Blanket or Shield Combustible Gas & Oxygen Meter

Spark Resistant Tools Fire Watch Explosion Proof Lighting

Other(s): Specify _____

12. Communication How will Entrants & Attendants Communicate?

Verbal Signal Rope Visual Radio Other: _____

What is the emergency evacuation signal? _____

What is the normal work signal to leave the space _____

13. Special Information / Additional Equipment / Decontamination

14. Planned Rescue & Emergency Service

How are rescues from outside-the-space to be done? _____

Describe what inside-the-space rescue provisions are to be used. _____

How will the Rescue Team be notified of the entry? _____

How will the Rescue Team be summoned for rescue? _____

How To Notify Entry is about to Start Verbal Intercom Phone Radio Other _____

How To Summon in Emergency Verbal Yell Horn
 Intercom Phone Radio Other _____

15. Worksheet Preparation and Approval

- The diagram and /or procedure do not match the physical surroundings.
- Required equipment not present or not functional.
- Non-functioning air monitoring device(s).
- Air contaminate above acceptable level or alarm sounding on monitoring device. (See air monitoring section)
- Conditions arise outside the scope of the original entry.
- Failure of lockout system, including blanking, bleeding, removing spool, etc.
- Failure of mechanical ventilation

Other (List) _____

Prepared By: _____ Date: _____ Prepared By: _____ Date _____
Prepared By: _____ Date: _____ Prepared By: _____ Date _____

16. Authorized Personnel

Entry Supervisor(s) _____

Authorized Entrant(s) _____

Authorized Attendant(s) _____

17. Training

1. All Entrants have received a Safe Job Description
2. All Entrants have received training on the Duties of an Entrant.
3. All Attendants have received a Safe Job Description
4. All Attendants have received training on the Duties of an Attendant.
5. All Rescue Team Members have received a Safe Job Description
6. All Rescue Team Members have received training on the Duties of a Rescue Team Member.

The Entry Supervisor(s) have reviewed the Duties of the Entry Supervisor and all sections of this permit to ensure completeness prior to anyone entering the confined space.

Permit Valid Start _____ / _____ / _____ a.m./p.m. **End** _____ / _____ / _____ a.m./p.m.

I have read the above permit and confirm that all items have been completed and therefore permit the entry to commence.

Entry Group Supervisor _____ Date _____ / _____ / _____ Time _____ a.m./p.m.

Unplanned Events _____

Permit Canceled by _____ Time _____ Date _____ / _____ / _____

Access Prevention & Warning Completed by _____ Time _____ Date _____ / _____ / _____

Part 4 Appendix A: Permit-Required Confined Space Decision Flow Chart

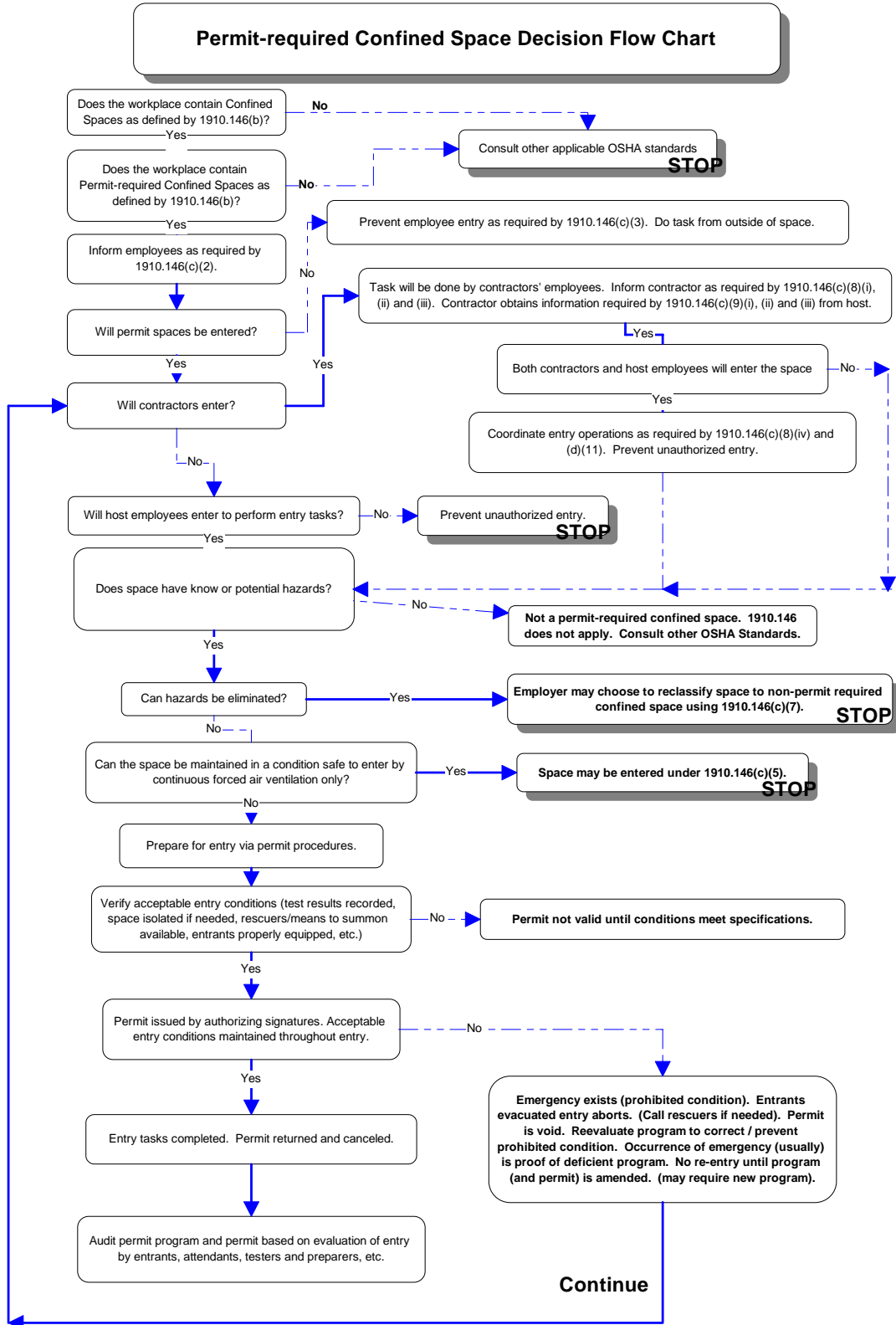

Part 5: Cranes, Derricks, Elevators & Hoists

CRANES AND DERRICKS

On school Construction Authority Projects where a crane, derrick, hoist or elevator is used Federal OSHA Standards, New York City Department of Building (DOB) Codes and School Construction Authority Safety Program and Procedures Manual and any other associated governing agencies rules, regulations, procedures and laws shall be adhered to and implemented. The most stringent of these standards shall be applicable.



SCA GENERAL REQUIREMENTS

Notification

In any case where a crane is brought onto a jobsite and/or is to be assembled or assist crane is used, or professionally engineered or requires the assistance of a master rigger, a minimum of 48 hours written notification must be given via e-mail or fax to the SCA Safety Director and/or the SCA Safety Officer. Use attached form (Notification of Crane - NOC)

Crane Requirements

These items must be considered when filing 48 hour Notification of Crane (NOC):

- a. A PE survey letter for placement of crane possessing a CD2 permit must be obtained by contractor for all crane placements
- b. The PE survey may be waived if a CD4 Form along with CD8 Form has been filed.
- c. After hours work variance is required from NYC DOB Cranes and Derricks when crane is operating beyond 6PM weekdays and at all times on Weekends and holidays and is placed on street/adjoining property. If Crane is within the property lines of the construction site then a regular after hours work permit from the NYC DOB is required. This variance must be for work involving a crane. Example: a weekend permits for masonry work cannot be used for lifting a ventilation unit.
- d. Valid CD2 permit registered with the NYC DOB.
- e. DOT permits for machinery on a street or public sidewalk.
- f. Transit approval letter must be received from any authority when crane will be set up above or within a reasonable distance from a subway tunnel, vault, or other underground transit culvert.

- g. Valid crane operator's license.
- h. Pre-lift inspection checklist form (see attached sample of Pre-Lift inspection checklist form)

Crane Inspections

Frequent (daily/monthly) and periodic (annual) inspection reports to be readily available for all cranes. See attached sample checklist which is intended as a general guideline and not to be considered as all inclusive.

Crane Restrictions

- a. The New York City School Construction Authority (NYSCA) does not permit the use of a crane or derrick with a suspended personal platform.
- b. Cranes or derricks shall not be operated when the wind speed *exceeds 30 mph*
- c. Cranes shall not be operated in severe weather such as Thunderstorms, snow or icy conditions, etc.
- d. No load shall be hoisted or swung over any occupied building, pedestrian pathway, vehicular traffic or arterial means of travel.
- e. No crane shall be erected on or near unstable soils, underground vaults or voids without proper paperwork submitted by a Professional Engineer (PE) to the NYC Department of Buildings (DOB), Cranes and Derricks Unit. Other applicable agencies (NYC MTA, Con Edison) may also have to be consulted. Subsequently, proof of receipt by aforementioned agencies as well as any pending approval will be necessary prior to lifting on an SCA Project.

Crane Filing

Verification of the following documents shall be the responsibility of the SCA Project Officer. The following documentation must be made available onsite for review by the SCA Safety Officer:

- a. Current and valid CD-2 for all cranes as defined by NYC DOB
- b. CD-3 are required for all Cranes, Cherry Pickers and Boom trucks with more than 50 feet of boom and less than 135 feet or less than 3 ton capacity
- c. Current, stamped approved CD-4; if applicable
- d. Valid Crane operator license issued by the NYC DOB
- e. Certificate of on site inspection (Form CN), if applicable
- f. Current inspection records
- g. CD-8 Foundation survey (10E, 10F)
- h. Copy of licenses for responsible "onsite" personnel: Master Rigger, Designated foreman and/or Site Safety Coordinator.
- i. For Crane use between hours of 6PM and 7AM and all hours of weekend and holiday where city agencies are closed: An after hour variance shall be obtained from the NYC DOB. Copy shall be available for review by the SCA safety officer. Permit shall be specific to crane use.
- j. Prior to commencement of crane or derrick operations in locations determined to fall within the parameters described in Chapter 33 of the NYC Building Code Safeguards During Construction and Demolition Code RS19-2 25-3 Operating Near Power Lines, a written statement by Con Edison Engineering Division shall be provided describing the appropriate protective measures that were implemented by Con Edison personnel. This document must be in the possession of the appointed person responsible for the operation and be made available for inspection by the SCA Safety Inspector.

Additional resources for Crane Information:

NYC Department of Building, Cranes and Derricks Division: 212-566-4696

Occupational Safety and Health Administration (OSHA): 212-337-2378

General Requirements

1. The employer (contractor, subcontractor and/or all employees) shall comply with the manufacturer's specifications and limitations applicable to the operation of any and all cranes and derricks. Where, manufacturer's specifications are not available, the limitation assigned to the equipment shall be based on the determinations of a qualified engineer competent in this field and such determinations will be appropriately documented and recorded. Attachments used with cranes shall not exceed the capacity, rating, or scope recommended by the manufacturer.
2. Rated load capacities, and recommended operating speed, special hazard warnings, or instruction shall be conspicuously posted on all equipment. Instructions or warnings shall be visible to the operator while he is at his control station.
3. Hand signals to crane and derrick operators shall be those prescribed by the applicable ANSI standard for the type of crane in use. Signals Person shall receive required training and provide certification of such training as required by the New York City Department of Buildings. An illustration of the signals shall be posted at the job site.
4. The employer shall designate a competent person who shall inspect all machinery and equipment prior to each use and during used, to make sure it is in safe operating condition. Any deficiencies shall be repaired, or defective parts replaced, before continued use.
5. A thorough, annual inspection of the hoisting machinery shall be made by a competent person or by a government or private agency recognized by the U.S. Department of Labor. The employer shall maintain a record of the dates and results of the inspections for each hoisting machine and piece of equipment.
6. Wire rope shall be taken out of service when any of the following exists;
 - a. In running ropes, six randomly distributed broken wires in one lay or three broken wires in one strand in one lay;
 - b. Wear of one third the original diameter of outside individual wires. Kinking, crushing, bird caging, or any other damage resulting in distortion of the rope structure.
 - c. Evidence of any heat damage from any cause
 - d. Reductions from nominal diameter of more than one sixty fourth inch for diameters up to and including five six tenths inch, one thirty second inch for diameters three eighths inch to and including one half inch, three sixty fourths inch for diameters nine sixteenths inch to and including three fourths inch, one sixteenth inch for diameters seven eighths inch to one and an eighth inches inclusive, three thirty seconds inch for diameters one and quarter to one and half inches inclusive
 - e. In standing ropes, more than two broken wires in one lay in sections beyond end connections or more than one broken wire at an end connection.
7. Wire rope safety factors shall be in accordance with American National Standards Institute B30.5 – 1968 or SAE J959-1966.
8. Belts, gears, shafts, pulleys, sprockets, spindles, drums, fly wheels, chains, or other reciprocating, rotating, or other moving parts or equipment shall be guarded if such parts are exposed to contact by employees, or otherwise create a hazard. Guarding shall meet the requirements of the American National Standards Institute B15.1-1958 Rev., Safety Code for Mechanical Power Transmission Apparatus.

9. Accessible areas within the swing radius of the rear of the rotating superstructure of the crane, either permanently or temporarily mounted, shall be barricaded in such a manner as to prevent an employee from being struck or crushed by the crane.
10. All exhaust pipes shall be guarded or insulated in areas where contact by employees is possible in the performance of normal duties.
11. Whenever internal combustion engine powered equipment exhausts in enclosed spaces, tests shall be made and recorded to see that employees are not exposed to unsafe concentrations of toxic gases or oxygen deficient atmospheres.
12. All windows in cabs shall be of safety glass, or equivalent, that introduces no visible distortion that will interfere with the safe operation of the machine.
13. Where necessary for rigging or service requirements, a ladder, or steps, shall be provided to give access to a cab roof.
14. Guardrails, handholds, and steps shall be provided on cranes for easy access to the car and cab, conforming to American National Standards Institute B30.5.
15. Platforms and walkways shall have anti skid surfaces.
16. Fuel tank filler pipe shall be located in such a position, or protected in such manner, as to not allow spill or overflow to run onto the engine, exhaust, or electrical equipment of any machine being fueled.
17. An accessible fire extinguisher of 5BC rating or higher, shall be available at all operator stations or cabs of equipment.
18. All fuels shall be transported, stored, and handled to meet the rules of subpart F of this part. When vehicles on public highways transport fuel, Department of Transportation rules contained in 49 CFR Parts 177 and 393 concerning such vehicular transportation are considered applicable.
19. Cage type boom guards, insulating links or proximity warning devices may be used on cranes, but the use of such devices shall not alter the requirements of any other regulation of this part even if such device is required by law or regulation.
20. Combustible and flammable materials shall be removed from the immediate area prior to operations.
21. The employer without the manufacturer's written approval shall make no modifications or additions, which affect the capacity for safe operation of the equipment. If such modifications or changes are made, the capacity, operation, and maintenance instruction plates, tags, or decals, shall be changed accordingly. In no case shall the original safety factor of the equipment be reduced.
22. All employees shall be kept clear of loads about to be lifted and of suspended loads.

Operating cranes near power lines

1. No crane or derrick shall be operated in such a location that any part of the machine or of its load shall at any time come within 15' of an energized power line.
2. Before the commencement of operations near electrical lines the appointed person responsible for the operation shall notify the owners of the lines or their authorized representatives providing them with all pertinent information and requesting their cooperation.
3. Any overhead wire shall be considered to be an energized line unless and until the person owning such line or the electrical utility authorities certify that it is not an energized line.
4. Prior to commencement of crane or derrick operations in locations determined to fall within the parameters described herein; a written statement by Con Edison Engineering Division shall be provided describing the appropriate protective measures that were implemented by Con Edison

personnel. This document must be in the possession of the appointed person responsible for the operation and be made available for inspection by the SCA Safety Inspector.

5. Grounding: Each crane, which may be operated in the vicinity of a live power line, shall be effectively grounded as hereinafter provided. The crane shall be provided with a permanent clamp or other means for convenient and effective attachment of a grounding conductor. The cable connecting the clamp to the ground shall be equivalent to a number 2 AWG or larger single conductor super flexible, rope stranded copper, composed of not less than 1600 individual wires, with 600 volt covering for mechanical protection and with terminal parts that ensure a good connection with hand tight screw clamps. An affective ground shall be one having a resistance of 25 ohms or less, which shall be measured, or a connection to a continuous underground metallic water piping system.
6. A person shall be designated to observe clearance of the equipment and give timely warning for all operations where it is difficult for the operator to maintain the desired clearance by visual means.
7. Prior to work near transmitter towers where an electrical charge can be induced in the equipment or materials being handled, the transmitter shall be de-energized or tests shall be made to determine if electrical charge is induced on the crane. The following precautions shall be taken when necessary to dissipate induced voltages;
 1. The equipment shall be provided with an electrical ground directly to the upper rotating structure supporting the boom; and
 2. Ground jumper cables shall be attached to materials being handled by boom equipment when electrical charge is induced while working near energized transmitters. Crews shall be provided with nonconductive poles having large alligator clips or other similar protection to attach the ground cable to the load.

Crawler, Locomotive and Truck Cranes

1. All jibs shall have positive stops to prevent their movement of more than 5 degrees above the straight line of the jib and boom on conventional type crane booms. The use of cable type belly slings does not constitute compliance with this rule.
2. All crawler, truck, or locomotive cranes in use shall meet the applicable requirements for design, inspection, construction, testing, maintenance and operation as prescribed in the ANSI B30.5-1968, Safety Code for Crawler, Locomotive and Truck Cranes. However, the written, dated, and signed inspection reports and records of the monthly inspection of critical items prescribed in section 5-2.1.5 of the ANSI B30.5-1968 standard are not required. Instead, the employer shall prepare a certification record which includes the date the crane items were inspected; the signature of the person who inspected the crane items, and a serial number, or other identifier, for the crane inspected. The most recent certification record shall be maintained on file until a new one is prepared.

Derricks

- All derricks in use shall meet the applicable requirements for design, construction, installation, inspection, testing, maintenance and operation as prescribed in
- American National Standards Institute B30.6-1969, Safety Code for Derricks.

MATERIAL HOISTS, PERSONNEL HOISTS, AND ELEVATORS

General Requirements

The employer (contractor, subcontractor and/or all employees) shall comply with the manufacturer's specifications and limitations applicable to the operation of all hoists and elevators. Where manufacturer's specifications are not available, the limitations assigned to the equipment shall be based on the determinations of a professional engineer competent in the field.

1. Rated load capacities, recommended operating speeds, and special hazard warnings or instructions shall be posted on cars and platforms.
2. Wire rope shall be removed from service when any of the following conditions exists;
 - a. in hoisting ropes, six randomly distributed broken wires in one rope lay or three broken wires in one strand in one rope lay
 - b. abrasion, scrubbing, flattening, or penning, causing loss of more than one third of the original diameter of the outside wires
 - c. evidence of any heat damage resulting from a torch or any damage caused by contact with electrical wires
 - d. reduction from nominal diameter of more than three sixty fourths inch for diameters up to and including three fourths inch and one sixteenth inch for diameters seven eighth to one and one eighth inches, and three thirty seconds inch for diameters one and one quarter to one and one half inches
3. Hoisting ropes shall be installed in accordance with the wire rope manufacturers' recommendations.
4. The installation of live booms on hoists is prohibited.
5. The use of endless belt type man lifts on construction shall be prohibited.
6. Material hoisting equipment shall at all times be maintained in good repair and proper operating condition with sufficient inspections to insure such maintenance. All defects affecting safety shall be immediately corrected by either necessary repairs or replacement of parts, or such defective equipment shall be immediately removed from the job site.
7. Only trained, designated persons shall operate hoisting equipment and such equipment shall be operated in a safe manner at all times.
8. Operators of material hoisting equipment shall remain at the controls while any load is suspended. Material hoisting equipment shall not be loaded in excess of the live load for which it was designed as specified by the manufacturer. Where there is any hazard to persons, all loads shall be properly trimmed to prevent dislodgment of any portions of such loads during transit. Suspended loads shall be securely slung and properly balanced before they are set in motion.
9. The owner or person directly in charge of any hoisting equipment shall immediately notify the commissioner following any accident involving hoisting equipment. Following an incident, no person shall permit either of the following, without the permission of the commissioner of the equipment:
 - a. -Use of such hoisting equipment or;
 - b. -Removal of the hoisting equipment or any part thereof from the area of the job site.
10. **Temporary elevator or hoist.** The maximum distance between the highest accessible floor from a temporary elevator or hoist and the working deck of the building under construction or demolition shall be no more than **75 feet** (13 716 mm) or 7 floors. In concrete construction, the working deck is the floor being formed. In steel construction the working deck is the floor where the metal

decking and steel components are being placed before concrete is poured. If the travel of the hoist cannot be increased due to inclement weather, it shall be increased by the end of the next working day

Operators and Signalmen

1. Material hoists shall be operated only in response to a signal system and all operators and signalmen shall be able to comprehend the signals readily and to execute them properly.
2. Where an overhead hazard exists, the operator of a hoisting machine shall be provided with overhead protection equivalent to tight planking not less than two inches thick which is supported to develop its full strength.
3. The area or space occupied by the hoisting machine and its operator shall be protected from the elements and shall be heated in cold weather to a temperature of at least 60 degrees Fahrenheit at all times such area or space is occupied.
4. Gears, belts, sprockets, drums, sheaves and points of contact between moving parts of power-driven hoist equipment, when not guarded by location, shall be guarded in compliance with this Part (rule) and with NYS Industrial Code Part (rule) 19.
5. Loads which have a tendency to swing or turn freely during hoisting shall be controlled by tag lines.
6. Riding on loads, buckets, slings, balls or hooks or material hoisting equipment is prohibited.

Hoisting Machines

Hoist brakes

Hoist brakes, capable of stopping and holding 150 percent of the rated capacity of the hoist, shall be provided for every material hoist. Each manually-operated material hoist shall be equipped with an effective pawl and ratchet capable of holding the rated load capacity when such a load is suspended. Each electric motor-driven material hoist shall be provided with a mechanical automatic motor brake or an electrical or mechanical device which will stop and hold 150 percent of the rated capacity of the hoist automatically in case of power failure.

Hoisting machine anchorage

Hoisting machines shall be so constructed, installed and secured in place as to prevent tipping or dislodgment.

No repairing, cleaning or lubricating of machinery shall be done unless such machinery is at rest.

Rigging, Rope, and Chains for Material Hoists

Hoisting Rope

Types required:

1. Only wire rope of the improved plow steel classification or equivalent having a safety factor of not less than six shall be used with power-driven hoisting machinery, except for winch heads or capstan hoists where fiber rope may be used.
2. Fiber rope shall be first grade Manila hemp or synthetic fiber. Means to prevent chafing shall be provided where necessary. Proper size blocks to accommodate the rope shall be used. Fiber rope shall be protected where acid or any other harmful or corrosive agent or chemical is used. All fiber rope shall be stored in a dry condition and in a dry place protected from the elements.

3. Fiber rope that is unsound in any way or that shows the effects of severe wear, deterioration or abrasion shall not be used and shall be removed from the job site. Frozen rope shall be thawed before being used.
4. The ends of wire rope shall be securely attached to the hoist drums and at least four turns of rope shall remain on each drum at all times.
5. Means shall be provided to prevent accidental contact with or damage to any hoisting rope. Such means shall consist of substantial covering, fencing or guarding by location.
6. Where clips are used as fastenings, the number used shall be in accordance with Table 2: Rope Clip Requirements below.
7. The spacing between clips shall be at least six times the diameter of the rope. The U-bolts of clips shall be placed over the short ends of the ropes.

Rope Clip Requirements	
Rope Diameter Up to and including)	Minimum Number of Clips
3/4 inch	3
1 inch	4
1 1/4 inches	5
1 5/8 inches	6
1 3/4 inches	7
2 1/2 inches	8
3 inches	9

Table 2: Rope Clip Requirements

Sheaves

Load-bearing sheaves for wire rope shall be of proper diameter and grooving to accommodate the rope but in no case shall such diameter be less than 20 times the diameter of the rope. Sheaves shall be maintained properly lubricated. Sheaves and blocks that are so excessively worn, damaged, deteriorated, or otherwise defective as to cause or threaten to cause failure of the equipment shall not be used. Sheaves intended for use with fiber rope shall not be used with wire rope.

Fittings

All hooks, shackles and other fittings subject to tension or shear shall be drop-forged. The use of deformed or damaged hooks, shackles, chains or other fittings is prohibited. All suspended pulley blocks, sheaves, well wheels or similar devices shall be moused or securely fastened or safety hooks shall be used.

Use of chains

Chains shall not be used as slings in hoisting operations

Material Platform or Bucket Hoists

Design Requirement

Every material platform or bucket hoist erected on SCA Projects shall be designed by a professional engineer licensed to practice in the State of New York. The design plans and specifications for any such hoist shall be kept on the job site available for examination. In addition, installation shall be filed and NYC D.O.B. permit obtained as per Local Law 52-05.

Material Hoist Towers

1. The tower of every material hoist shall be supported by a firm foundation of such dimensions and area as to adequately distribute the intended load so as not to exceed the safe load-bearing capacity

of the supporting soil. Tower bracing shall be constructed of such material and shall be so installed as to secured tower stability and rigidity and to keep the tower plumb.

2. The erection and dismantling of any material hoist tower shall be performed only under the direct supervision of a designated person experienced in this type of work.
3. Hoist towers constructed of metal shall not be erected to a height exceeding 50 feet above the highest portion of the buildings or other structures which may be used as suitable anchorages for guying such towers.
4. Hoist towers shall be so constructed that there shall be at least four feet of clearance between the lowest point on the circumference of the cathead sheave and the highest point on the hoisting rope fastening on the car or bucket when such conveyance is at the uppermost terminal or landing.

Hoistway Enclosures

Interior hoistways for material hoists shall be enclosed at every floor level to a height of at least eight feet on all sides except entrance openings. Such enclosures shall be constructed of wire mesh of not less than No. 18 U.S. gage steel with openings which will reject a one-half inch diameter ball or such enclosures shall be partitions of exterior grade plywood at least three-quarters inch thick, of wood slats not less than three-quarters inch thick installed horizontally and spaced not more than two inches apart or of other material of equivalent strength. Such enclosures shall be adequately supported, braced and secured.

Enclosed Exterior

When any exterior hoistway for a material hoist is enclosed, such enclosure shall extend from the lowest terminal points to the cathead elevations on all sides except entrance openings. Such enclosures shall be constructed of wire mesh of not less than No. 18 U.S. gage steel with openings which will reject a one-half inch diameter ball.

Unenclosed Exterior

When any exterior hoistway for a material hoist is unenclosed, the following requirements shall apply:

1. Such hoistway shall be enclosed at the ground or grade level to a height of at least six feet on all sides except entrance openings. Such enclosure shall be constructed of wire mesh of not less than No. 18 U.S. gage steel with openings which will reject a one-half inch diameter ball. Entrance openings of any such hoistway shall be provided with gates or bars in compliance with this Part (rule) except that sliding bars may be used in lieu of hinged bars. Such gates or bars shall be kept closed whenever the car is hoisted.
2. In addition to the enclosure of the hoist car as required by this Part (rule), each loading side of any such car shall be provided with a self-closing gate at least 66 inches in height, constructed of the same material as the car enclosure.
3. Where any point on a moving car or counterweight of a material hoist passes less than eight feet from a floor, roof, scaffold platform or other work surface or position, such floor, roof, scaffold platform or other work surface shall be provided with a partition at least six feet in height. Such partition shall extend horizontally at least five feet past the horizontal projection of the path of the car or counterweight. Such partition shall be at least equal in construction to hoistway enclosures as specified in this Part (rule).

Entrances to Hoistways

1. All entrances to any hoistway used for material hoisting above the lowest loading terminal or grade entrance shall be guarded by substantial gates painted fluorescent orange or yellow. When closed, such gates shall guard the full width of the entrance openings. The top of each such gate shall be at least 36 inches in height above the floor surface when located two feet or more from the hoistway line. Any such gate located less than two feet from the hoistway line shall be not less than 66 inches in height above the floor surface. If such entrance gates are constructed with a grille, wire mesh, lattice or other openwork material, the openings therein shall reject a ball more

than two inches in diameter. Any such gate shall have an under clearance of not more than two inches. Such entrance gates shall be vertical sliding, horizontal sliding or swinging gates. Any swinging gate shall swing in the direction of egress from the car to the floor.

2. At the lowest loading terminal or grade entrance, a wood or metal bar may be used to guard the entrance to a hoistway used for material hoisting. Such bar shall be painted fluorescent orange or yellow. Such bar shall be mechanically or electrically interlocked with the hoist car so that the bar shall be closed and locked before the car can leave the lowest terminal or grade level and cannot be opened until the car has returned to such level.
3. Bars or pipes shall not be used to guard hoistway entrances at any level or floor above the lowest terminal or grade level.
4. Gates at hoistway entrances above the lowest terminal or grade level shall be kept closed when the car is not at such entrances.

Car Construction

1. Hoist cars used for material hoisting shall be enclosed from floor to crosshead with solid enclosures on all sides not used for loading or unloading. Every such hoist car shall be provided with overhead protection installed at the crosshead to protect any person from falling objects or materials. Such overhead protection shall consist of planking at least two inches thick, exterior grade plywood at least three-quarters inch thick or other material of equivalent strength.
2. In lieu of solid enclosures, hoist cars may be enclosed with expanded metal of not less than No. 9 U.S. gage steel with openings which will reject a one and one-half inch diameter ball. Such enclosed cars shall also be provided with toeboards at least four inches in height on all sides except those used for loading and unloading.
3. Car platforms shall be provided with securely fastened blocks and cleats to prevent the rolling of wheeled vehicles and the shifting of other equipment.

Guide Rails

The guide rails of material hoists shall be constructed of steel or sound, structural grade hardwood securely fastened at intervals so as not to deflect more than one-quarter inch during normal operation of the hoist.

Operation of Hoist

The operation of any hoist car, bucket or platform is prohibited whenever persons are climbing the hoist tower or working on any part of the tower below the cathead.

Loading and Roping of Platform Hoists

The maximum safe capacity of each platform hoist shall be determined by using a factor of safety of eight. Such maximum safe capacity shall be posted conspicuously on the crosshead or side members of every such hoist and such capacity shall not be exceeded.

Riding

Riding by any person on a material hoist is prohibited except for necessary inspection, maintenance and repairs. Signs to that effect shall be posted in conspicuous locations on both sides of the crosshead or side members and at every entrance to any such hoist. The legend on every such sign, in letters not less than one and one-half inches in height on contrasting backgrounds, shall read as follows: "WARNING – RIDING BY ANY PERSON PROHIBITED."

Temporary Personnel or Workmen's Hoists

Approval Required

Temporary personnel hoists shall not be placed in service until such installation has been filed and permits granted by the Building Department. The requirements of any such approval shall be applied in conjunction with all other requirements of this section, and with Local Law 52-05.

Hoist Towers

1. Every hoist tower used for a temporary personnel hoist shall be supported by a firm foundation of such dimensions as to adequately distribute the transmitted load so as not to exceed the safe load-bearing capacity of the ground upon which such tower is erected. Each such hoist tower shall be securely braced to the building or other structure so that such tower is held in a plumb vertical position, is stable, rigid and able to withstand wind pressure.
2. Each such hoist tower shall be secured with guys or rigid braces at each corner at intervals not to exceed 26 feet vertically. Tower guys shall be at least one-half inch diameter improved plow steel wire rope and shall be securely fastened to adequate anchorages with wire rope clips as specified in Table 2: Rope Clip Requirements on page 114 (Subpart 23-6 of this Past rule). All building tie-ins shall be identified by metal tags bearing the legend: "WORKMEN'S HOIST – DO NOT REMOVE".
3. Hoist towers shall be erected and dismantled only under the direct supervision of qualified, designated persons.
4. Hoist towers shall be erected only to heights necessary for the performance of the work and shall be extended in height only when construction has progressed sufficiently in height in order to provide for the adequate anchorages and bracing required by this Subpart unless other safe and adequate guying can be provided.

Hoistway Enclosures

Interior hoistways for temporary personnel hoists shall be fully enclosed at every floor except for entrance openings. Such enclosures shall be constructed of wire mesh of not less than No. 18 U.S. gage steel with openings which will reject a one-half inch diameter ball or such enclosures shall be partitions of exterior grade plywood at least three-eighths inch thick, of wood slats not less than three-quarters inch thick installed horizontally and spaced not more than two inches apart or of other material of equivalent strength. Such enclosures shall be adequately supported, braced and secured.

Enclosed Exterior

When exterior hoistways for personnel hoists are enclosed, such enclosures shall extend from the lowest terminal points to the cathead elevations on all sides except entrance openings. Such enclosures shall be constructed of wire mesh of not less than No. 18 U.S. gage steel with openings which will reject a one-half inch diameter ball.

Unenclosed Exterior

When exterior hoistways for personnel hoists are unenclosed, the following requirements shall apply:

1. Every such hoistway shall be enclosed at the ground or grade level to a height of at least 10 feet on all sides except entrance openings. Such enclosures shall be constructed of wire mesh of not less than No.18 U.S. gage steel with openings that will reject a one-half inch diameter ball. The entrance openings of such hoistways shall be guarded in compliance with this section.
2. Where any point on a moving car or counterweight passes less than eight feet from a floor, scaffold platform or other work surface or position, such floor, scaffold platform or other work surface so exposed shall be provided with a partition at least six feet in height. Such partition shall

extend horizontally at least five feet past the horizontal project of the path of the car or counterweight. Such partition shall be at least equal in construction to hoistway enclosures as specified in this section.

Hoistway Doors

1. Every entrance opening in any hoistway enclosure for a personnel hoist shall be provided with a solid door at least 78 inches in height which shall extend across the full width of the opening. Such door shall be provided with a vision panel securely covered with wire mesh. Such door shall be provided with a lock or latch which is openable from the hoistway side only and inaccessible from the landing side. Every such door shall have an underclearance of not more than one-half inch.
2. In normal service every hoistway door shall be locked or latched shut except when in use for passage to or from the car. No person except the car attendant shall open any such door.
3. Hoistway entrance doors shall be hung to provide durability and shall be securely reinforced.

Car Enclosures

The car of every personnel hoist shall be permanently enclosed on all sides and the top except the side used for entrance or exit. Such enclosure shall be equivalent in strength to two-inch planking laid tight. The top of every such enclosure shall be provided with an emergency exit opening fitted with a hinged hatch cover. Such exit opening shall be not less than 16 inches in its smallest dimension and not less than 400 square inches in area.

Car Doors or Gates

1. Each landing side of any car used in a personnel hoist shall be provided with a door or gate at least six feet in height constructed of material at least as equivalent in strength as the car enclosure.
2. Every opening in such door or gate shall be of such size and shape as to reject a three-inch diameter ball at any point.
3. Every such car shall be equipped with an approved electrical contact so arranged that the car cannot be operated unless each door or gate is shut.

Lighting

Inside the hoistway car and at each landing means for artificial lighting shall be provided. The insides of hoistway cars, landings and spaces occupied by hoisting machines shall be illuminated in compliance with the SCA Safety Manual at all times.

Materials Carried on Personnel Hoists

Personnel hoists may be used for carrying material providing the rated load capacity of the hoists are not exceeded. When materials are being carried on such a hoist, only the person necessary for handling such materials shall be permitted to ride in the car, in addition to the operator. When concentrated loads are carried in such a hoist car, such loads shall not exceed 25 percent of the rated load.

Car Attendant or Operator

1. Any car of a temporary personnel hoist shall not be operated in service unless such car is in the charge of a designated person stationed in the car as its attendant or operator.
2. No person other than such car attendant shall cause or permit the car to move or shall open any car door or gate or hoistway door. The car attendant shall not cause the car to move until he is sure that the car door or gate and the hoistway doors are dosed.
3. Persons designated as car attendants for temporary personnel hoists shall be over 18 years of age, trained, qualified and competent to operate the cars of such hoists.

Hoisting Machine Enclosures

Where a hoisting machine is located inside a building or other structure, such machine shall be effectively guarded in compliance with this Part (rule). Where a hoisting machine is located outside a building or other structure, such machine shall be enclosed or barricaded in compliance with this Part (rule) and, in addition, shall be provided with substantial overhead protection. Such overhead protection shall consist of planking at least two inches thick full size, exterior grade plywood at least three-quarters inch thick or material of equivalent strength.

Inspection and Testing

Prior to use, initially and after any extension, every temporary personnel hoist shall be tested. Such testing shall be performed only by a designated person and shall consist of the following:

1. A running test with rated load and at rated speed with stops at each landing.
2. A test of the normal and final terminal stopping devices with no load carried in the upward direction and with full load carried in the downward direction.
3. A test of the car safety device at rated load and at rated speed.
4. A test of the car speed governor.
5. A complete written report of every such test shall be made and signed by the designated person making such tests. Such reports shall include the dates of the tests, the test loads and speeds involved and the results of such test. Such reports shall be kept in a log book on the job site available for examination by the commissioner.

Safety factors

Safety Factor Value

Use the following table to determine which safety factor to use according to rope speed.

Minimum Factors or Safety for Suspension Wire Ropes	
Rope Speed (in feet per minute)	Minimum Factor of Safety
50	7.60
75	7.75
100	7.95
125	8.10
150	8.25
175	8.40
200	8.60
225	8.75
250	8.90
300	9.20
350	9.50
400	9.75
450	10.00
500	10.25
550	10.45
600	10.70

Table 3: Minimum Factors or Safety for Suspension Wire Ropes

Safety Factor Procedure

Safety factor suspension wire rope procedures are as follows:

1. Following assembly and erection of hoists, and before being put in service, an inspection and test of all functions and safety devices shall be made under the supervision of a competent person. A similar inspection and test is required following major alteration of an existing installation. All hoists shall be inspected and tested at not more than 3-month intervals. The employer shall prepare a certification record which includes the date the inspection and test of all functions and safety devices was performed; the signature of the person who performed the inspection and test; and a serial number, or other identifier, for the hoist that was inspected and tested. The most recent certification record shall be maintained on file.
2. All personnel hoists used by employees shall be constructed of materials and components which meet the specifications for materials, construction, safety devices, assembly, and structural integrity as stated in the American National Standard A10.4-1963, Safety Requirements for Workmen's Hoists. The requirements of this paragraph (18) do not apply to cantilever type personnel hoists.
3. Personnel hoists used in bridge tower construction shall be approved by a registered professional engineer and erected under the supervision of a qualified engineer competent in this field.
4. These hoists shall be inspected and maintained on a weekly basis. Whenever the hoisting equipment is exposed to winds exceeding 35 miles per hour it shall be inspected and put in operable condition before reuse.
5. Wire rope shall be taken out of service when any of the following condition exist:
 1. In running ropes, six randomly distributed broken wires in one lay or three broken wires in one strand in one lay
 2. Wear of one third the original diameter of outside individual wires. Kinking, crushing, bird caging, or any other damage resulting in distortion of the rope structure
 3. Evidence of any heat damage from any cause
 4. Reduction from nominal diameter of more than three sixty fourth inch for diameters to and including three fourths inch, in sixteenth inch for diameters seven eighth inch to one and one eighth inches inclusive, three thirty seconds inch for diameters one an7d one quarter to one and one half inches inclusive
 5. In standing ropes, more than two broken wires in one lay in sections beyond end connections or more than one broken wire at an end connection
 6. Permanent elevators under the care and custody of the employer and used by employees for work covered by this Act shall comply with the requirements of American National Standards Institute A17.1-1965 with addenda A17.1a-1967, A17.1b-1968, 17.1c-1969, A17.1d-1970, and inspect4d in accordance with A17.2-1960 with addenda A17.2a-1965, A17.2b-1967.

Base-Mounted Drum Hoists

1. Exposed moving parts such as gears, projecting screws, setscrews, chain, cables, chain sprockets, and reciprocating or rotating parts, which constitute a hazard, shall be guarded.
2. All controls used during the normal operation cycle shall be located within easy reach of the operator's station.
3. Electric motor operated hoists shall be provided with:
 1. A device to disconnect all motors from the line upon power failure and not permit any motor to be restarted until the controller handle is brought to the "off" position
 2. A means whereby remotely operated hoists stop when any control is ineffective
 3. Where applicable, an overspend preventive device

4. All base mounted drum hoists in use shall meet the applicable requirements for design, construction, installation, testing, inspection, maintenance, and operation, as prescribed by the manufacturer.

Overhead Hoists

1. The safe working load of the overhead hoist, as determined by the manufacturer, shall be indicated on the hoist, and this safe working load shall not be exceeded.
2. The supporting structure to which the hoist is attached shall have a safe working load equal to that of the hoist.
3. The support shall be arranged so as to provide for free movement of the hoist and shall not restrict the hoist from lining itself up with the load.
4. The hoist shall be installed only in locations that will permit the operator to stand clear of the load at all times.
5. Air hoists shall be connected to an air supply of sufficient capacity and pressure to safely operate the hoist. All air hoses supplying air shall be positively connected to prevent their becoming disconnected during use.
6. All overhead hoists in use shall meet the applicable requirements for construction, design, installation, testing, inspection, maintenance, and operation, as prescribed by the manufacturer.

Part 5 Checklist: Pre-Lift Setup Checklist

For use by Project Officers.

Pre-Lift Setup Checklist

Yes/No **Preparation: Prior to setting up cranes, SCA project Officers should walk areas where cranes are to be set up and discuss with GC and subcontractor the following:**

Foundation:

Is ground where crane will be set up stable and soil identified?

Are there any subways, rail tunnels, etc. near the crane set up area?

Are there any voids or vaults?

If yes, have the proper subway or transit authorities been notified or consulted?

If there are concerns with stability, has an engineer been assigned to evaluate the soil and foundation?

Has the soil / foundation been approved for the crane and load considerations?

Is there documentation for it?

If not, has a cribbing design been submitted by the engineer?

Are there any backswing concerns for the cranes cab? (Residents, cars, utility poles etc.)

Power Lines:

Are there any power lines present next to or beneath any area where the crane boom or load will swing/lift?

If yes, have the sources been identified and has energy provider (e.g. Con Edison) been consulted for precautions?

If yes, have power-lines been protected, moved or has letter from utility company been provided stating lines are de-energized or low voltage?

Off Hours:

Will the crane be operating outside of normal work hours? (Weekdays, 6PM-7AM)

If not is an after hours work permits (NYCDOB) in place?

Has the SCA Safety Office been notified? (Forms available, SCA Safety Manual)

Area for load:

Is area where material being lifted an occupied building or will other workers be working in the building?

Will any other person(s) be working in the vicinity of the crane?

If yes, has their Safety been addressed?

If the building is occupied has the owner been notified?

Will the top floor(s) have to be evacuated prior to the lift?

Will any other areas of the building have to be protected from unauthorized personnel? (Penthouse doors, stairwells)

Will any residents or neighboring structures be affected by the swing of the load?

If yes have they been notified, protected?

Will parking lanes, traffic lanes be affected or altered?

Have the proper New York City DOT permits been filed?

Will additional traffic measures need to be taken? Barricades, detours signs, Police assigned, etc.

If roads are being closed or traffic detoured, will signs be posted 48 hours in advance of operation as per New York City DOT rules?

Will private vehicles need to be moved from street or parking lots?

Continued on next page.

Pre-Lift Setup Checklist Continued

Day of lift:

Has the SCA Project Officer verified the following paperwork prior to all crane set ups:

NYC DOT permits for any road closures, limitations

CD-2 Forms for ALL cranes and hoisting trucks

CD 4 Permits on site (If applicable)

Are engineered drawings attached? (If applicable)

Is a Master Rigger assigned? (Verify license)

After hours work permit

Additional forms for NYC Department of Buildings (Form CD8, CD3 etc)

Cranes Licenses verified for all operators

Pre Operational Inspection been performed and documented by crane operator or competent person?

Additional Items of concern:

Flag person(s) stationed at all roadway entrances.

Pedestrian traffic closed or detoured

All rigging for lift been inspected by competent person

Pre Lift meeting held and documented (As per NYC Dept. of Buildings)

Hand signals or other means of communication been established for crane operator and signal person

Building, areas cleared of unauthorized personnel

Part 5 Form: Notification of Crane (NOC)

The SCA Safety Unit requires 48 hour notification prior to arrival of all cranes and hoisting mechanisms that are intended for use on all SCA projects. Written notification and all pertinent documents shall be submitted to the SCA Safety Unit for review prior to mobilization of equipment.



NOTICE of CRANE (NOC)

The SCA Safety Unit requires notification of all cranes and hoisting mechanisms that are intended for use on projects. Notification must be received within 48 hours prior to mobilization of equipment.

Complete all applicable items noted below and forward the Notice, via e-mail, to mluther@nycsca.org; rfuriero@nycsca.org; Kkhorsandi@nycsca.org or send via facsimile SCA Safety Unit at: (718) 472-8640.

Note* PE survey letter for placement of Crane is MANDATORY for on all SCA Projects

Projected Date of Crane Use	School	Project Officer	Crane Company	Crane Type	Crane Size	GC

Material Being Lifted	Estimated Wt. of Material	Duration of Crane at Site	Rigging Company			Check One
						Y <input type="checkbox"/> N <input type="checkbox"/>

1. Are DOT permits needed for street/sidewalk closure?
2. Is a Professional Engineer assigned?
3. Is a Master Rigger assigned?
4. Are power/electrical lines present?
5. Has the foundation for placement of crane (PE Survey letter) been approved by an Engineer?
6. Are rail or subway lines present? If so, has NYCTA/MTA been notified of equipment?
7. Has GC filed for after hour work variance from DOB Cranes and Derricks for crane use?

(All Crane work not on site (In streets or adjacent property) and working between 6PM-7AM and all weekends and holidays shall obtain an After Hours Work Variance from the NYCDOB Cranes and Derricks Unit)

Additional Comments/Concerns:

Name of Person Filing: _____ Date Filed: _____

Organization Name: _____

Revised 10/8/08

Part 5 Form: Sample Crane Inspection

SAMPLE MOBILE CRANE /LIFTING ACTIVITIES

Date: _____

Location: _____

Crane: Make _____ Model _____ Capacity _____ ID _____

Operator: _____

I. CRANE SET-UP

Yes No

- | | | |
|-----|-----|--|
| ___ | ___ | Is crane level? |
| ___ | ___ | Are outriggers fully extended? |
| ___ | ___ | If outriggers are not fully extended, is there a load chart for the intermediate position? |
| ___ | ___ | Is adequate blocking used beneath each outrigger pad? |
| ___ | ___ | Is each pad level? |
| ___ | ___ | Is crane set up near an excavation or near the top of a retaining wall? |
| ___ | ___ | Are the tires completely off the ground if on outriggers? (If not request proof that no significant load is on the tires.) |
| ___ | ___ | Is there any blocking under the outrigger beams or crane body? |
| ___ | ___ | Is the lift zone barricaded? |
| ___ | ___ | Is the tail swing zone barricaded? |
| ___ | ___ | Has the crane been improperly counterweighted to increase capacity? |
| ___ | ___ | Are there any hydraulic fluid leaks, especially at outrigger cylinders? |
| ___ | ___ | |

Comments: _____

II. CRANE FEATURES

<u>Yes</u>	<u>No</u>	
___	___	Are windows clean, free of cracks and unobstructed by posters, curtains, shades, etc?
___	___	Is there a properly inspected and fully charged fire extinguisher on the crane?
___	___	Does the crane have a hoist limiting (anti two-block or A2B) device?
___	___	Does the hoist limiting device work properly? Ask for demonstration that it works. If this safety feature is absent or is not functional, it is recommended that the crane be taken out of service immediately.
___	___	Are there boom limit switches? Ask for demonstration that they work.
___	___	Is there evidence of damage to any boom sections?
___	___	Are any chords or lattice (lacing) members bent?
___	___	Is there a tape measure in the cab and is it used?
___	___	Does the crane have some type of load indicating system? If this safety feature is absent or not functional, recommend the crane be taken out of service immediately.
___	___	Has the load indicating system been calibrated in the last six months?
___	___	If equipped with an on-board computer, has the computer been programmed with the correct counterweight?
___	___	Is the rope wound on the drums properly?
___	___	Is the appropriate lift chart in the cab?
___	___	Is the appropriate operator's manual in the cab?
___	___	

Comments: _____

III. CRANE OPERATIONS

Yes No

___ ___ Is the operator out of the cab while a load is on the hook?

___ ___ Does the crane luff and slew smoothly?

___ ___ Does the hoist line start and stop smoothly and slowly?

A. TRAVELING A CRANE

___ ___ If warning signals are available, are they used when approaching workmen, blind corners, etc.?

___ ___ Is the (lattice) boom as low as safely practicable?

___ ___ Has telescopic boom been lowered to the traveling position?

___ ___ Is the swing lock engaged and the swing brake set?

___ ___ Is the empty hook snubbed or otherwise restrained from swinging?

___ ___ Is anyone riding on the crane?

___ ___ Does crawler crane have the boom pointed uphill when traveling up or down a slope?

___ ___ Is there a designated person responsible for safety who determines boom position, route of travel, speed, etc.?

Comments: _____

B. PICK AND CARRY

1. CRAWLER MOUNTED CRANES

<u>Yes</u>	<u>No</u>	
___	___	Does the operator have all the required permits?
___	___	Is the ground level and smooth?
___	___	Is any soil strength improvement necessary?
___	___	If there are underground facilities in the travel path, has their strength been evaluated?
___	___	Have sudden starts and stops been avoided?
___	___	Is the boom as short as possible?
___	___	Is the boom pointed in the direction of travel?
___	___	If not, does the crane need to be de-rated?
___	___	Have all the relevant braking and locking devices been set?
___	___	Is the load as close to the ground as possible?
___	___	Does the operator know the manufacturer's recommended speed of travel? How is the travel speed being measured / monitored?
___	___	Are tag lines in place to control swinging of the load?
___	___	Is a signal person available to walk with the crane and assist the operator?
___	___	
___	___	
___	___	

Comments: _____

B. PICK AND CARRY (Cont'd)

2. RUBBER TIRE MOUNTED CRANES

<u>Yes</u>	<u>No</u>	
___	___	Does the operator have all the required permits?
___	___	Are the recommended tire inflation pressures known to the operator?
___	___	Are the tires inflated per the manufacturer's recommendations?
___	___	Has the strength of underground facilities in the travel path been considered?
___	___	Is the recommended travel speed known to the operator?
___	___	How is the travel speed being monitored / measured?
___	___	Have sudden starts and stops been avoided?
___	___	Is the boom as short as possible?
___	___	Is the boom pointed in the direction of travel?
___	___	Are all relevant braking and locking devices set?
___	___	Is the load as close to the ground as possible?
___	___	Are tag lines in place to control swinging of the load?
___	___	
___	___	
___	___	
___	___	
___	___	

Comments: _____

IV. CRANE OPERATOR

Yes No

___ ___ Can the operator tell you the maximum capacity of the crane in its present configuration?

___ ___ Can the operator tell you the size and capacity of the load line?

___ ___ Does the operator know at what minimum boom angle the crane can be safely operated?

___ ___ Do all people involved know and understands the hand signals being used?

___ ___ Is there more than one signal person?

___ ___ Does the operator know the capacity of the block in use?

___ ___ Has the operator had the site safety indoctrination?

___ ___

___ ___

___ ___

Comments: _____

V. RIGGING

<u>Yes</u>	<u>No</u>	
___	___	Are all slings equipped with legible tags showing the safe working load?
___	___	Check the condition of the hoist line at several locations. Are there any broken strands visible?
___	___	If broken strands exit, should the line be taken out of service?
___	___	Is there a system to identify equipment (slings, etc.) not suitable for service?
___	___	Are there any cable clips on the live line at wedge sockets?
___	___	Are cable clips installed properly?
___	___	Are any sling eyes formed with cable clips?
___	___	Are wire rope slings in good condition? Check for storage conditions, broken strands, condition of sleeves, kinks, etc.
___	___	Are synthetic slings in good condition? Check for rips, cuts, tears, melted fibers etc.
___	___	Do all lifting hooks have safety clips?
___	___	Is there significant wear evident on shackles, master links, hooks, etc.?
___	___	Are the hoist lines twisted?
___	___	Does the block spin when hoisting?
___	___	
___	___	
___	___	

Comments: _____

VI. OTHER

Yes

No

Are tag lines used to control loads being lifted?

Is anybody ever touching the load before it is landed?

Are there overhead power lines in the area?

If yes, are adequate precautions being taken?

Does everyone know who is in charge of the lift?

Is a crane permit system in use?

Comments: _____

Part 6: Demolition

INTRODUCTION

On School Construction Authority Projects where demolition is to take place, Federal OSHA Standards, New York City Department of Building Codes and School Construction Authority Safety Program and Procedures Manual and any other associated governing agencies rules, regulations, procedures and laws shall be adhered to. The most stringent of these standards shall be applicable.



SCA GENERAL REQUIREMENTS

1. Proper Permits shall be obtained, prior to the commencement of any demolition activities, from the New York City Building Department for the type of demolition to take place, ie; hand or mechanical.
2. Demolition Permits are to be readily available on site for review.
3. Proper sidewalk bridges are to be in place as necessary on all demolition projects as indicated by the Approved Site Safety Plan.
4. Demolition on any portion of an occupied school premise is to take place after school hours, including but not limited to after school programs and scheduled activities.
5. Protection of Adjacent structures, property, and sidewalks is to be accomplished prior to commencement of demolition activities.
6. Proper personal protective equipment is to be worn throughout demolition process including but not limited to hard hats, work boots, glasses, fall protection.
7. Dust control is to be implemented to eliminate hazards where dust presents a health hazard, environmental hazard, damage to property.
8. Any entry point or gate openings are to be closed and secured during all demolition activities.
9. Demolition debris is not to remain on any portion of a roof top or sidewalk bridge structure. These areas are to be cleaned daily.

PREPARATORY OPERATIONS

1. Prior to permitting employees to start demolition operations, an engineering survey shall be made by a competent person, of the structure to determine the condition of the framing, floor, and walls, and possibility of unplanned collapse of any portion of the structure. Any adjacent structure where employees may be exposed shall also be similarly checked. The employer shall have in writing evidence that such a survey has been performed.

2. When employees are required to work within a structure to be demolished which has been damaged by fire, flood, explosion or other cause, the walls or floor shall be shored or braced.
3. All electric, gas, water, steam, sewer, and other service lines shall be shut off, capped, or otherwise controlled, outside the building line before demolition work is started. In each case, any utility company, which is involved, shall be notified in advance.
 - a. If it is necessary to maintain any power, water or other utilities during demolition, such lines shall be temporarily relocated, as necessary, and protected.
 - b. It shall also be determined if any type of hazardous chemicals, gases, explosive, flammable materials, or similarly dangerous substances have been used in any pipes, tanks, or other equipment on the property. When the presence of any such substances is apparent or suspected, testing and purging shall be performed and the hazard eliminated before demolition is started.
4. Where a hazard exists from fragmentation of glass, such hazards shall be removed.
5. Where a hazard exists to employees falling through wall openings, the opening shall be protected to a height of approximately 42 inches.
6. When debris is dropped through holes in the floor without the use of chutes, the area onto which the material is dropped shall be completely enclosed with barricades not less than 42 inches high and not less than 6 feet back from the projected edge of the opening above. Signs, warning of the hazard of falling materials, shall be posted at each level. Removal shall not be permitted in this lower area until debris handling ceases above.
7. All floor openings, not used as material drops, shall be covered over with material substantial enough to support the weight of any load, which may be imposed. Such material shall be properly secured to prevent its accidental movement. ALL COVERS SHALL BE MARKED "FLOOR HOLE DO NOT REMOVE COVER."
8. Except for the cutting of holes in floors for chutes, holes through which to drop materials, preparation of storage space, and similar necessary preparatory work, the demolition of exterior walls and floor construction shall begin at the top of the structure and proceed downward. Each story of exterior wall and floor construction shall be removed and dropped into the storage space before commencing the removal of exterior walls and floors in the story next below.
9. Employee entrances to multi-story structures being demolished shall be completely protected by a sidewalk sheds or canopies, or both, providing protection from the face of the building for a minimum of 8 feet. All such canopies shall be at least 2 feet wider than the building entrances or openings (1 foot wider on each side thereof) and shall be capable of sustaining a load of 150 pounds per square foot.

STAIRS, PASSAGEWAYS AND LADDERS

1. Only those stairways, passageways and ladders, designated as means of access to the structure of a building, shall be used. Other access ways shall be entirely closed at all times.
2. All stairs, passageways, ladders and incidental equipment thereto, which are covered by this section, shall be periodically inspected and maintained in a clean, safe condition.
3. In a multistory building, when a stairwell is being used, it shall be properly illuminated by either natural or artificial means, and completely and substantially covered over at a point not less than two floors below the floor on which work is being performed, and access to the floor where the work is in progress shall be through a properly lighted, protected and separate passageway.

CHUTES

1. No material shall be dropped to any point lying outside the exterior walls of the structure .
2. All materials chutes or sections thereof, at an angle of more than 45 degrees from the horizontal, shall be entirely enclosed except for the openings equipped with closures at or about floor level for the insertion of materials. The openings shall not exceed 48 inches in height measured along the wall of the chute. At all stories below the top floor, such openings shall be kept closed when not in use.
3. A substantial gate shall be installed in each chute at or near the discharge end. A competent employee shall be assigned to control the operation of the gate, and the backing and loading of trucks.
4. When operations are not in progress, the area surrounding the discharge end of a chute shall be securely closed off.
5. Any chute opening, into which workmen dump debris shall be protected by a substantial guardrail approximately 42 inches above the floor or other surface on which the men stand to dump the material. Any space between the chute and the edge of openings in the floors through which it passes shall be solidly covered over.
6. Where the material is dumped from mechanical equipment or wheel barrows, a securely attached toeboard or bumper, not less than four inches (4") thick and six inches (6") high, shall be provided at each chute opening.
7. Chutes shall be designed and constructed of such strength as to eliminate failure due to impact of materials or debris loaded therein.
8. Every chute used to convey material from a building shall be rigidly supported at its top and braced midway in its height.
9. All chutes constructed of combustible material shall be covered on the exterior with corrugate steel sheeting having a minimum thickness of 24 gauge through the entire height. Alternatively, chutes shall be constructed of non-combustible material: Chutes exceeding 75 feet in height.
10. All structural supports of material chutes shall be of noncombustible material.

REMOVAL OF DEBRIS THROUGH FLOOR OPENINGS

Any openings cut in a floor for the disposal of materials shall be no larger in size than 25 percent of the aggregate of the total floor area. Floors weakened or otherwise made unsafe by demolition operations shall be shored or braced to carry safely the intended imposed load from demolition operations.

REMOVAL OF WALLS, MASONRY SECTION AND CHIMNEYS

1. Masonry walls, or other sections of masonry, shall not be permitted to fall upon the floors of the building in such masses as to exceed the safe carrying capacities of the floors.
2. No wall section, which is more than one story in height shall be permitted to stand alone without lateral bracing, unless such wall was originally designed and constructed to stand without such lateral support, and is in a condition safe enough to be self supporting. All walls shall be left in a stable condition at the end of each shift.
3. Employees shall not be permitted to work on the top of a wall when weather conditions constitute a hazard.

4. Structural or load supporting members on any floor shall not be cut or removed until all stories above such a floor have been demolished and removed. This provision shall not prohibit the cutting of floor beams for the disposal of materials or for the installation of equipment provided the terms addressed under manual Removal of Floors (preceding) is followed.
5. Floor openings within 10 feet of any wall being demolished shall be planked solid, except when employees are kept out of the area below.
6. In building of “skeleton-steel” construction, the steel framing may be left in place during the demolition of masonry. Where this is done, all steel beams, girders, and similar structural supports shall be cleared of all loose material as the masonry demolition progresses downward.
7. Walkways or ladders shall be provided to enable employees to safely reach or leave any scaffold or wall.
8. Walls, which serve, as retaining walls to support earth or adjoining structures, shall not be demolished until such earth has been properly braced or adjoining structures have been properly underpinned.

MANUAL REMOVAL OF FLOORS

1. Openings cut in a floor shall extend the full span of the arch between supports.
2. Before demolishing any floor arch, debris and other material shall be removed from such arch and other adjacent floor area. Planks not less than two inches (2”) by ten inches (10”) in cross section, full size undressed, shall be provided for, and shall be used by employees to stand on while breaking down floor arches between beams. Such planks shall be so located as to provide a safe support for the workmen should the arch between the beams collapse. The open space between planks shall not exceed sixteen inches (16”).
3. Safe walkways, not less than eighteen inches (18”) wide, formed of planks not less than two inches (2”) thick if wood or of equivalent strength if metal, shall be provided and used by workmen when necessary to enable them to reach any point without walking upon exposed beams.
4. Stringer of ample strength shall be installed to support the flooring planks and the ends of such stringers shall be supported by floor beams or girders, and not by floor arches alone.
5. Planks shall be laid together over solid bearings with the ends overlapping at least one foot (1’).
6. When floor arches are being removed, employees shall not be allowed in the area directly underneath, and such an area shall be barricaded to prevent access to it.
7. Demolition of floor arches shall not be started until the, and the surrounding floor area for a distance of twenty feet (20’), have been cleared of debris and any other unnecessary materials.

REMOVAL OF WALLS, FLOOR AND MATERIAL WITH EQUIPMENT

1. Mechanical equipment shall not be used on floors or working surfaces unless such floors or surfaces are of sufficient strength to support the imposed load.
2. Floor openings shall have curbs or stop logs to prevent equipment from running over the edge.
3. Mechanical equipment used shall meet the requirements specified by the NYC Building Department as well as in OSHA Subparts N – Cranes, Derricks, Hoists, Elevators and Conveyors and OSHA Subpart O – Motor Vehicles, Mechanized Equipment and Marine Operations.

STORAGE

1. The storage of waste material and debris on any floor shall not exceed the allowable floor loads.
2. In buildings having wooden floor construction, the flooring boards may be removed from not more than one floor above grade to provide storage space for debris, provided falling material is not permitted to endanger the stability of the structure.
3. When wood floor beams serve to brace interior walls or free standing exterior walls, such beams shall be left in place until other equivalent support can be installed to replace them.
4. Floor arches, with an elevation of not more than twenty five feet (25') above grade, may be removed to provide storage area for debris; *provided, that such removal does not endanger the stability of the structure.*
5. Storage space into which material is dumped shall be locked off; except for openings necessary for the removal of material. Such openings shall be kept closed at all times when material is not being removed.
6. Storage spaces shall not interfere with access to any stairway or passageway.

REMOVAL OF STEEL CONSTRUCTION

1. When floor arches have been removed planking in accordance with #2 under Manual Removal of Floors, shall be provided for and the workers engaged in razing steel framing.
2. When pulling over walls or portions thereof, all steel members affected shall have been previously cut free.
3. All roof cornices or other such ornamental stonework shall be removed prior to pulling walls over.
1. During demolition, continuing inspection by a competent person shall be made as the work progresses to detect hazards resulting from weakened or deteriorated floors, or walls, or loosened material. No employee shall be permitted to work where such hazards exist until they are corrected by shoring, bracing or other effective means.

Part 7: Electrical

INTRODUCTION

On School Construction Authority Projects where electrical installations are to take place, Federal OSHA Standards, current New York City Department of Building Codes and School Construction Authority Safety Program & Procedures Manual and other governing agencies, rules, regulations, procedures and laws shall be adhered to. The most stringent of these standards shall be applicable.



SCA GENERAL REQUIREMENTS

1. Assured Equipment Grounding Programs are not permitted.
2. Extension cords are not permitted to be spliced or taped.
3. All temporary electric (wiring & lighting) must be listed, tested and approved by a qualified testing laboratory.
4. Permits must be readily available on site.
5. Written Lock Out Tag Out Program is to be readily available on site when applicable.
6. Power Strips, extension cords and/or Power Surge Protectors not listed as heavy duty are not permitted for use on construction sites.
7. The use of Romex Wire is not permitted on SCA Projects.
8. The Licensed Electrician responsible for installation of the temporary electrical service is to provide a certificate of inspection from the NYC Bureau of Electric Control (BEC) or in lieu of said BEC inspection, a certification letter executed by a NYC Licensed electrician attesting that the temporary service has been installed in accordance with all applicable codes.

Single strand single insulated wire shall not be used for temporary wiring or temporary lighting.

BASIC TERMINOLOGY

Definitions for the following terms are listed alphabetically within the Glossary located at the back of this publication:

- Acceptable
- Accepted
- Accessible Equipment
- Accessible Wiring Methods
- Ampacity
- Appliances
- Approved
- Attached
- Automatic
- Conductor
- Building
- Cabinet
- Ground
- Ground-Fault Circuit Interrupter
- Guarded
- Identified
- Conductor
- Interrupter Switch
- Isolated
- Labeled
- Lighting Outlet
- Listed
- Panelboard
- Power Outlet
- Premises Wiring System
- Qualified
- Qualified Testing Laboratory
- Receptacle
- Weatherproof
-

APPROVAL

All electrical conductors and equipment shall be in accordance with SCA technical specification requirements.

EXAMINATION, INSTALLATION, AND USE OF EQUIPMENT

The employer shall ensure that electrical equipment is free from recognized hazards that are likely to cause death or serious physical harm to employees. Safety of equipment shall be determined on the basis of the following considerations:

1. Suitability for installation and use in conformity with the provisions of this subpart. Suitability of equipment for an identified purpose may be evidenced by listing, labeling, or certification for that identified purpose.
2. Mechanical strength and durability, including, for parts designed to enclose and protect other equipment, the adequacy of the protection thus provided.

GUARDING OF LIVE PARTS

1. Except as required or permitted elsewhere in this subpart, live parts of electric equipment operating at 50 volts or more shall be guarded against accidental contact by cabinets or other forms of enclosures, or by any of the following means:
2. By location in a room, vault, or similar enclosure that is accessible only to qualified persons.
3. By partitions or screens so arranged that only qualified persons will have access to the space within reach of the live parts. Any openings in such partitions or screens shall be so sized and

located that persons are not likely to come into accidental contact with the live parts or to bring conducting objects into contact with them.

4. By location on a balcony, gallery, or platform so elevated and arranged as to exclude unqualified persons.
5. By elevation of 8 feet (2.44 m) or more above the floor or other working surface and so installed as to exclude unqualified persons.
6. In locations where electric equipment would be exposed to physical damage, enclosures or guards shall be so arranged and of such strength as to prevent such damage.
7. Entrances to rooms and other guarded locations containing exposed live parts shall be marked with conspicuous warning signs forbidding unqualified persons to enter.

GENERAL REQUIREMENTS FOR TEMPORARY WIRING

1. Feeders shall originate in a distribution center. The conductors shall be run as multiconductor cord or cable assemblies or within raceways; or, where not subject to physical damage, they may be run as open conductors on insulators not more than 10 feet (3.05 m) apart.
2. Branch circuits shall originate in a power outlet or panelboard. Conductors shall be run as multiconductor cord or cable assemblies or open conductors, or shall be run in raceways. All conductors shall be protected by overcurrent devices at their ampacity. Runs of open conductors shall be located where the conductors will not be subject to physical damage, and the conductors shall be fastened at intervals not exceeding 10 feet (3.05 m). No branch-circuit conductors shall be laid on the floor. Each branch circuit that supplies receptacles or fixed equipment shall contain a separate equipment grounding conductor if the branch circuit is run as open conductors.
3. Receptacles shall be of the grounding type. Unless installed in a complete metallic raceway, each branch circuit shall contain a separate equipment grounding conductor, and all receptacles shall be electrically connected to the grounding conductor. Receptacles for uses other than temporary lighting shall not be installed on branch circuits which supply temporary lighting. Receptacles shall not be connected to the same ungrounded conductor of multiwire circuits which supply temporary lighting.
4. Disconnecting switches or plug connectors shall be installed to permit the disconnection of all ungrounded conductors of each temporary circuit.
5. All lamps for general illumination shall be protected from accidental contact or breakage. Metal-case sockets shall be grounded.
6. Temporary lights shall not be suspended by their electric cords unless cords and lights are designed for this means of suspension.
7. Portable electric lighting used in wet and/or other conductive locations:



Example: Drums, tanks, and vessels, shall be operated at 12 volts or less. However, 120-volt lights may be used if protected by a ground-fault circuit interrupter.

8. A box shall be used wherever a change is made to a raceway system or a cable system which is metal clad or metal sheathed.
9. All temporary lighting fixtures installed in wet or damp locations shall be identified for that purpose and shall be installed so that water cannot enter or accumulate in wire ways, lamp holders, or other electrical parts [OSHA Subpart K : §1926.405(j)(1)(v)].
10. Flexible cords and cables shall be protected from damage. Sharp corners and projections shall be avoided. Flexible cords and cables may pass through doorways or other pinch points, if protection is provided to avoid damage.

11. Extension cord sets used with portable electric tools and appliances shall be of three-wire type and shall be designed heavy duty use. Flexible cords used with temporary and portable lights shall be designed for heavy duty use.
12. Guarding. For temporary wiring over 600 volts, nominal, fencing, barriers, or other effective means shall be provided to prevent access of other than authorized and qualified personnel.

CABINETS, BOXES, AND FITTINGS

1. Conductors entering boxes, cabinets, or fittings. Conductors entering boxes, cabinets, or fittings shall be protected from abrasion, and openings through which conductors enter shall be effectively closed. Unused openings in cabinets, boxes, and fittings shall also be effectively closed.
2. Covers and canopies. All pull boxes, junction boxes, and fittings shall be provided with covers. If metal covers are used, they shall be grounded. In energized installations each outlet box shall have a cover, faceplate, or fixture canopy. Covers of outlet boxes having holes through which flexible cord pendants pass shall be provided with bushings designed for the purpose or shall have smooth, well-rounded surfaces on which the cords may bear.
3. Complete enclosure. Boxes shall provide a complete enclosure for the contained conductors or cables.
4. All temporary electric service panels and installations are to be designed for exterior use or enclosed in a weatherproof cabinet that is secured in an elevated manner where the base is not lower than three feet (3') above the walking/working surface.
5. Boxes shall be closed by covers securely fastened in place. Underground box covers that weigh over 100 pounds (43.6 kg) meet this requirement. Covers for boxes shall be permanently marked "HIGH VOLTAGE." The marking shall be on the outside of the box cover and shall be readily visible and legible.

FIXTURE WIRES – GENERAL

Fixture wires shall be suitable for the voltage, temperature, and location of use. A fixture wire which is used as a grounded conductor shall be identified.

Use Fixture wires for the following:

1. Installation in lighting, fixtures and in similar equipment where enclosed or protected and not subject to bending or twisting in use
2. Connecting lighting fixtures to the branch-circuit conductors supplying the fixtures

EQUIPMENT FOR GENERAL USE

1. Lighting fixtures, lampholders, lamps, and receptacles. Live parts Fixtures, lampholders, lamps, rosettes, and receptacles shall have no live parts normally exposed to employee contact. However, rosettes and cleat-type lampholders and receptacles located at least 8 feet (2.44 m) above the floor may have exposed parts.
2. Support. Fixtures, lampholders, rosettes, and receptacles shall be securely supported. A fixture that weighs more than 6 pounds (2.72 kg) or exceeds 16 inches (406 mm) in any dimension shall not be supported by the screw shell of a lampholder.

3. Portable lamps. Portable lamps shall be wired with flexible cord and an attachment plug of the polarized or grounding type. If the portable lamp uses an Edison-based lampholder, the grounded conductor shall be identified and attached to the screw shell and the identified blade of the attachment plug.

Portable handlamps shall comply with the following:

- a. Metal shell, paperlined lampholders shall not be used;
 - b. Handlamps shall be equipped with a handle of molded composition or other insulating material;
 - c. Handlamps shall be equipped with a substantial guard attached to the lampholder or handle;
 - d. Metallic guards shall be grounded by the means of an equipment grounding conductor run within the power supply cord.
4. Lampholders of the screw-shell type shall be installed for use as lampholders only. Lampholders installed in wet or damp locations shall be of the weatherproof type.
 5. Fixtures installed in wet or damp locations shall be identified for the purpose and shall be installed so that water cannot enter or accumulate in wireways, lampholders, or other electrical parts.

INTERRUPTING AND ISOLATING DEVICES

A means shall be provided to completely isolate equipment for inspection and repairs. A means designed not to interrupt the load current of the circuit but to be either interlocked with a circuit interrupter or provided with a sign warning against opening them under load.

Circuit Breakers

Circuit breakers located indoors shall consist of metal-enclosed or fire-resistant, cell-mounted units. Open mounting of circuit breakers is not permitted. A means of indicating the open and closed position of circuit breakers shall be provided. Circuits within the temp electric panel boxes are to be properly identified (labeled) in accordance with OSHA Subpart K §1926.403(h).

Fused Cutouts

Fused cutouts installed in buildings or transformer vaults shall be of a type identified for the purpose. They shall be readily accessible for fuse replacement.

MOBILE AND PORTABLE EQUIPMENT

Power cable connections to mobile machines

A metallic enclosure shall be provided on the mobile machine for enclosing the terminals of the power cable. The enclosure shall include provisions for a solid connection for the ground wire(s) terminal to ground effectively the machine frame. The method of cable termination used shall prevent any strain or pull on the cable from stressing the electrical connections. The enclosure shall have provision for locking so only authorized qualified persons may open it and shall be marked with a sign warning of the presence of energized parts.

Guarding live parts

All energized switching and control parts shall be enclosed in effectively grounded metal cabinets or enclosures. Circuit breakers and protective equipment shall have the operating means projecting through the metal cabinet or enclosure so these units can be reset without locked doors being opened. Enclosures and metal cabinets shall be locked so that only authorized qualified persons have access and shall be marked with a sign warning of the presence of energized parts. Collector ring assemblies on revolving-type machines (shovels, draglines, etc.) shall be guarded.

PROTECTION OF EMPLOYEES

1. No employer shall permit an employee to work in such proximity to any part of an electric power circuit that the employee could contact the electric power circuit in the course of work, unless the employee is protected against electric shock by de-energizing the circuit and grounding it or by guarding it effectively by insulation or other means.
2. In work areas where the exact location of underground electric power lines is unknown, employees using jack-hammers, bars, or other hand tools which may contact a line shall be provided with insulated protective gloves.
3. Before work is begun the employer shall ascertain by inquiry or direct observation, or by instruments, whether any part of an energized electric power circuit, exposed or concealed, is so located that the performance of the work may bring any person, tool, or machine into physical or electrical contact with the electric power circuit. The employer shall post and maintain proper warning signs where such a circuit exists. The employer shall advise employees of the location of such lines, the hazards involved, and the protective measures to be taken.

PASSAGEWAYS AND OPEN SPACES

1. Barriers or other means of guarding shall be provided to ensure that workspace for electrical equipment will not be used as a passageway during periods when energized parts of electrical equipment are exposed.
2. Working spaces, walkways, and similar locations shall be kept clear of cords so as not to create a hazard to employees.

LOAD RATINGS

In existing installations, no changes in circuit protection shall be made to increase the load in excess of the load rating of the circuit wiring.

FUSES

When fuses are installed or removed with one or both terminals energized, special tools insulated for the voltage shall be used.

CORDS AND CABLES

1. Worn or frayed electric cords or cables shall not be used.
2. Extension cords shall not be fastened with staples, hung from nails, or suspended by wire.

CONTROLS

Controls that are to be deactivated during the course of work on energized or de-energized equipment or circuits shall be tagged.

EQUIPMENT AND CIRCUITS

Equipment or circuits that are de-energized shall be rendered inoperative and shall have tags attached at all points where such equipment or circuits can be energized.

TAGS

1. Tags shall be placed to identify plainly the equipment or circuits being worked on.
2. The employer shall ensure that all wiring components and utilization equipment in hazardous locations are maintained in a dust-tight, dust-ignition-proof, or explosion-proof condition, as appropriate. There shall be no loose or missing screws, gaskets, threaded connections, seals, or other impairments to a tight condition.

DETERIORATING AGENTS

Unless identified for use in the operating environment, no conductors or equipment shall be located:

1. In damp or wet locations;
2. Where exposed to gases, fumes, vapors, liquids, or other agents having a deteriorating effect on the conductors or equipment; or
3. Where exposed to excessive temperatures.

Control equipment, utilization equipment, and bus ways approved for use in dry locations only shall be protected against damage from the weather during building construction.

PROTECTION AGAINST CORROSION

Metal raceways, cable armor, boxes, cable sheathing, cabinets, elbows, couplings, fittings, supports, and support hardware shall be of materials appropriate for the environment in which they are to be installed.

Part 8: Excavations

INTRODUCTION

On School Construction Authority Projects where trenching/excavation is to take place Federal OSHA Standards, current New York City Department of Building Codes and School Construction Safety Program & Procedures Manual and any other governing agencies rules, regulations, laws and procedures shall be adhered to. The most stringent of these standards shall be applicable.

BASIC TERMINOLOGY

Definitions for the following terms are listed alphabetically within the Glossary located at the back of this publication:

- Accepted
- Aluminum Hydraulic Shoring
- Bell Bottom Pier Hole
- Benching
- Cave In
- Competent Person
- Cross Braces
- Excavation
- Faces or Sides
- Hazardous Atmosphere
- Kick Out
- Protective System
- Ramp
- Registered Professional Engineer
- Shield
- Shore
- Faces or Sides
- Sloping
- Structural Ramp
- Support System
- Tabulated Data
- Trench
- Uprights
- Wales

GENERAL REQUIREMENTS

This subpart applies to all open excavations made in the earth's surface. Excavations are defined to include trenches.

Earthwork (Excavation) Notification Fast Track Initiative FACT SHEET

To help ensure that earthwork is conducted safely and according to the Building Code, the NYC Department of Buildings is launching a Fast Track Initiative: Earthwork (Excavation) Notification. This initiative aims to strengthen the enforcement of Department of Buildings Rule 1 RCNY § 52-01.

◆ Effective October 25, 2006, all permit holders conducting earthwork (excavation) must notify the Buildings Department of the date and time of excavation at least 24 - 48 hours before the start of earthwork by calling (212) 227-4416. This notification is now a requirement as per 1 RCNY § 52-01. The Buildings Department will audit a sample of all notices received. The audit will consist of unannounced site visits by our Forensic Engineering Unit and Building Enforcement Safety Team (BEST) during the time specified on the notification. While onsite, the inspectors will photograph the excavation and adjacent areas and will review the following:

- o Ensuring Engineer is On Site
- o Excavation Depth
- o Pumping Operations
- o Pile Driving Operations
- o Sheeting/Shoring/Bracing
- o Angle of Repose
- o Forms Bracing
- o Underpinning
- o Ground Water
- o Work as per Plan

◆ If the permit holder does not provide notification of the intended earthwork, a violation for “failure to notify” may be written. If a violation has been issued or for additional information on earthwork/excavation inspections contact the BEST Unit at (212) 669-7043.

Department & Adjacent Property Owner Notification

No earthwork within the property line shall commence unless the permit holder notifies the Department of Buildings, via phone or electronically, at least 24 hours, but no more than 48 hours prior commence such work.

When an excavation to a depth of 5 to 10 feet (1524 mm to 3048 mm) is to be made within 10 feet (3048 mm) of an adjacent building, or when any excavation over 10 feet (3048 mm) is to be made anywhere on the site, the person causing an excavation to be made shall provide written notice to the owners of the adjacent building or buildings not less than 10 days prior to the scheduled starting date of the excavation. The written notice shall provide a description of the work to be performed, the timeframe and schedule, and contact information of the person causing the excavation and of the department.

Protection of Adjacent Property - Responsibility

Person causing excavation or fill to be made is now responsible for protection of adjacent property regardless of depth of excavation

Drainage

All excavations shall be drained and the drainage maintained as long as the excavation continues or remains. Where necessary, pumping shall be used, provided proper permits are obtained from the New York City Department of Environmental Protection.

The Commissioner may issue a minimum three-day Stop Work Order if work is found to violate any of the provisions of the Building Code, Zoning Resolution or other applicable laws, rules or regulations at a site where proper notice was not provided as required.

Note: While the Buildings Department will be monitoring excavation work, this does not relieve site engineers and contractors from their professional responsibilities.

For more information, see Department of Buildings Rule 1 RCNY § 52-01, available online at www.nyc.gov/buildings.

SURFACE ENCUMBRANCES

All surface encumbrances that are located so as to create a hazard to employees shall be removed or supported, as necessary, to safeguard employees.

UNDERGROUND INSTALLATIONS

1. The estimated location of utility installations, such as sewer, telephone, fuel, electric, water lines, or any other underground installations that reasonably may be expected to be encountered during excavation work, shall be determined prior to opening an excavation.
2. Utility companies or owners shall be contacted within established or customary local response times, advised of the proposed work, and asked to establish the location of the utility underground installations prior to the start of actual excavation. When utility companies or owners cannot respond to a request to locate underground utility installations within 24 hours (unless a longer period is required by state or local law), or cannot establish the exact location of these installations, the employer may proceed, provided the employer does so with caution, and provided detection equipment or other acceptable means to locate utility installations are used.
3. When excavation operations approach the estimated location of underground installations, the exact location of the installations shall be determined by safe and acceptable means.
4. While the excavation is open, underground installations shall be protected, supported or removed as necessary to safeguard employees.

ACCESS AND EGRESS

Structural Ramps

1. Structural ramps that are used solely by employees as a means of access or egress from excavations shall be designed by a competent person. Structural ramps used for access or egress of equipment shall be designed by a competent person qualified in structural design, and shall be constructed in accordance with the design.
2. Ramps and runways constructed of two or more structural members shall have the structural members connected together to prevent displacement.
3. Structural members used for ramps and runways shall be of uniform thickness.
4. Cleats or other appropriate means used to connect runway structural members shall be attached to the bottom of the runway or shall be attached in a manner to prevent tripping.
5. Structural ramps used in lieu of steps shall be provided with cleats or other surface treatments on the top surface to prevent slipping.

Trench Excavations

A stairway, ladder, ramp or other safe means of egress shall be located in trench excavations that are 4 feet (1.22 m) or more in depth so as to require no more than 25 feet (7.62 m) of lateral travel for employees.

EXPOSURE TO VEHICULAR TRAFFIC

Employees exposed to public vehicular traffic shall be provided with, and shall wear, warning vests or other suitable garments marked with or made of reflectorized or high-visibility material.

EXPOSURE TO FALLING LOADS

No employee shall be permitted underneath loads handled by lifting or digging equipment. Employees shall be required to stand away from any vehicle being loaded or unloaded to avoid being struck by any spillage or falling materials. Operators may remain in the cabs of vehicles being loaded or unloaded when the vehicles are equipped, in accordance with 1926.601(b)(6), to provide adequate protection for the operator during loading and unloading operations.

WARNING SYSTEM FOR MOBILE EQUIPMENT

When mobile equipment is operated adjacent to an excavation, or when such equipment is required to approach the edge of an excavation, and the operator does not have a clear and direct view of the edge of the excavation, a warning system shall be utilized such as barricades, hand or mechanical signals, or stop logs. If possible, the grade should be away from the excavation.

HAZARDOUS ATMOSPHERES

Testing and Controls

1. Where oxygen deficiency (atmospheres containing less than 19.5 percent oxygen) or a hazardous atmosphere exists or could reasonably be expected to exist, such as in excavations in landfill areas or excavations in areas where hazardous substances are stored nearby, the atmospheres in the excavation shall be tested before employees enter excavations greater than 4 feet (1.22 m) in depth.
2. Adequate precautions shall be taken to prevent employee exposure to atmospheres containing less than 19.5 percent oxygen and other hazardous atmospheres. These precautions include providing proper respiratory protection or ventilation in accordance with subparts D and E of this part respectively.
3. Adequate precaution shall be taken such as providing ventilation, to prevent employee exposure to an atmosphere containing a concentration of a flammable gas in excess of 20 percent of the lower flammable limit of the gas.
4. When controls are used that are intended to reduce the level of atmospheric contaminants to acceptable levels, testing shall be conducted as often as necessary to ensure that the atmosphere remains safe.

Emergency Rescue Equipment

1. Emergency rescue equipment, such as breathing apparatus, a safety harness and line, or a basket stretcher, shall be readily available where hazardous atmospheric conditions exist or may reasonably be expected to develop during work in an excavation. This equipment shall be attended when in use.
2. Employees entering bell-bottom pier holes, or other similar deep and confined footing excavations, shall wear a harness with a lifeline securely attached to it. The lifeline shall be

separate from any line used to handle materials, and shall be individually attended at all times while the employee wearing the lifeline is in the excavation.

Protection from Water Accumulation

1. Employees shall not work in excavations in which there is accumulated water, or in excavations in which water is accumulating, unless adequate precautions have been taken to protect employees against the hazards posed by water accumulation. The precautions necessary to protect employees adequately vary with each situation, but could include special support or shield systems to protect from cave-ins, water removal to control the level of accumulating water, or use of a safety harness and lifeline.
2. If water is controlled or prevented from accumulating by the use of water removal equipment, the water removal equipment and operations shall be monitored by a competent person to ensure proper operation.
3. If excavation work interrupts the natural drainage of surface water (such as streams), diversion ditches, dikes, or other suitable means shall be used to prevent surface water from entering the excavation and to provide adequate drainage of the area adjacent to the excavation. Excavations subject to runoff from heavy rains will require an inspection by a competent person and compliance with paragraphs (1) and (2) of this section.

STABILITY OF ADJACENT STRUCTURES

1. Where the stability of adjoining buildings, walls, or other structures is endangered by excavation operations, support systems such as shoring, bracing, or underpinning shall be provided to ensure the stability of such structures for the protection of employees.
2. Excavation below the level of the base or footing of any foundation or retaining wall that could be reasonably expected to pose a hazard to employees shall not be permitted except when:
3. A support system, such as underpinning, is provided to ensure the safety of employees and the stability of the structure; or the excavation is in stable rock; or a registered professional engineer has approved the determination that the structure is sufficiently removed from the excavation so as to be unaffected by the excavation activity; or a registered professional engineer has approved the determination that such excavation work will not pose a hazard to employees.
4. Sidewalks, pavements and appurtenant structure shall not be undermined unless a support system or another method of protection is provided to protect employees from the possible collapse of such structures.

PROTECTION OF EMPLOYEES FROM LOOSE ROCK OR SOIL

1. Adequate protection shall be provided to protect employees from loose rock or soil that could pose a hazard by falling or rolling from an excavation face. Such protection shall consist of scaling to remove loose material; installation of protective barricades at intervals as necessary on the face to stop and contain falling material; or other means that provide equivalent protection.
2. Employees shall be protected from excavated or other materials or equipment that could pose a hazard by falling or rolling into excavations. Protection shall be provided by placing and keeping such materials or equipment at least 2 feet (.61 m) from the edge of excavations, or by the use of retaining devices that are sufficient to prevent materials or equipment from falling or rolling into excavations, or by a combination of both if necessary.

INSPECTIONS

1. Daily inspections of excavations, the adjacent areas, and protective systems shall be made by a competent person for evidence of a situation that could result in possible cave-ins, indications of failure of protective systems, hazardous atmospheres, or other hazardous conditions. An inspection shall be conducted by the competent person prior to the start of work and as needed throughout the shift. Inspections shall also be made after every rainstorm or other hazard increasing occurrence. These inspections are only required when employee exposure can be reasonably anticipated.
2. Where the competent person finds evidence of a situation that could result in a possible cave-in, indications of failure of protective systems, hazardous atmospheres, or other hazardous conditions, exposed employees shall be removed from the hazardous area until the necessary precautions have been taken to ensure their safety.

FALL PROTECTION

Walkways shall be provided where employees or equipment are required or permitted to cross over excavations. Guardrails, which comply with the Fall Protection section of this Safety Program, shall be provided where walkways are 6 feet (1.8 m) or more above lower levels.

PROTECTION OF EMPLOYEES IN EXCAVATIONS

1. Each employee in an excavation shall be protected from cave-ins by an adequate protective system designed in accordance with paragraph “Design of Sloping and Benching Systems” and “Design of Support Systems, Shield Systems and Other Protective Systems” of this section except when:
 - a. Excavations are made entirely in stable rock
 - b. Excavations are less than 5 feet (1.52 m) in depth and examination of the ground by a competent person provides no indication of a potential cave-in
2. Protective systems shall have the capacity to resist without failure all loads that are intended or could reasonably be expected to be applied or transmitted to the system.

DESIGN OF SLOPING AND BENCHING SYSTEMS

The slopes and configurations of sloping and benching systems shall be selected and constructed by the employer or his designee and shall be in accordance with the requirements of Option 1; or, in the alternative, Option 2; or, in the alternative, Option 3; or, in the alternative, Option 4, as follows:

Option 1 - Allowable Configurations and Slopes

Excavations shall be sloped at an angle not steeper than one and one-half horizontal to one vertical (34 degrees measured from the horizontal), unless the employer uses one of the other options listed below. Slopes herein specified shall be excavated to form configurations that are in accordance with the slopes shown for Type C soil in Appendix B to this subpart.

Option 2 - Determination of Slopes and Configurations

Use Appendices A and B. Maximum allowable slopes, and allowable configurations for sloping and benching systems, shall be determined in accordance with the conditions and requirements set forth in appendices A and B to this subpart.

Option 3 - Designs Using Other Tabulated Data

1. Designs of sloping or benching systems shall be selected from and in accordance with tabulated data, such as tables and charts.
2. The tabulated data shall be in written form and shall include all of the following:
 - a. Identification of the parameters that affect the selection of a sloping or benching system drawn from such data
 - b. Identification of the limits of use of the data, to include the magnitude and configuration of slopes determined to be safe
 - c. Explanatory information as may be necessary to aid the user in making a correct selection of a protective system from the data
3. At least one copy of the tabulated data, which identifies the registered professional engineer who approved the data, shall be maintained at the jobsite during construction of the protective system. After that time the data may be stored off the jobsite, but a copy of the data shall be made available to the Secretary upon request.

Option 4 - Design by a Registered Professional Engineer

1. Sloping and benching systems not utilizing the above Option (1) or Option (2) or Option (3) shall be approved by a registered professional engineer.
2. Designs shall be in written form and shall include at least the following:
 - a. Magnitude of the slopes that were determined to be safe for the particular project
 - b. Configurations that were determined to be safe for the particular project
 - c. Identity of the registered professional engineer approving the design
3. At least one copy of the design shall be maintained at the jobsite while the slope is being constructed. After that time the design need not be at the jobsite, but a copy shall be made available to the Secretary upon request.

DESIGN OF SUPPORT SYSTEMS, SHIELD SYSTEMS, AND OTHER PROTECTIVE SYSTEMS

Designs of support systems, shield systems, and other protective systems shall be selected and constructed by the employer or his designee and shall be in accordance with the requirements of Option 1; or, in the alternative, Option 2; or, in the alternative, Option 3; or, in the alternative, Option 4 as follows:

Option 1 - Designs Using Appendices A, C, and D

Designs for timber shoring in trenches shall be determined in accordance with the conditions and requirements set forth in appendices A and C to this subpart. Designs for aluminum hydraulic shoring shall be in accordance with Option 2 of this section, but if manufacturer's tabulated data cannot be utilized, designs shall be in accordance with appendix D.

Option 2 - Designs Using Manufacturer's Tabulated Data

1. Design of support systems, shield systems, or other protective systems that are drawn from manufacturer's tabulated data shall be in accordance with all specifications, recommendations, and limitations issued or made by the manufacturer.
2. Deviation from the specifications, recommendations, and limitations issued or made by the manufacturer shall only be allowed after the manufacturer issues specific written approval.
3. Manufacturer's specifications, recommendations, and limitations, and manufacturer's approval to deviate from the specifications, recommendations, and limitations shall be in written form at the jobsite during construction of the protective system. After that time this data may be stored off the jobsite, but a copy shall be made available to the Secretary upon request.

Option 3 - Designs Using Other Tabulated data

1. Designs of support systems, shield systems, or other protective systems shall be selected from and be in accordance with tabulated data, such as tables and charts.
2. The tabulated data shall be in written form and include all of the following:
 - a. Identification of the parameters that affect the selection of a protective system drawn from such data
 - b. Identification of the limits of use of the data
 - c. Explanatory information as may be necessary to aid the user in making a correct selection of a protective system from the data.
3. At least one copy of the tabulated data, which identifies the registered professional engineer who approved the data, shall be maintained at the jobsite during construction of the protective system. After that time the data may be stored off the jobsite, but a copy of the data shall be made available to the Secretary upon request.

Option 4 - Design by a Registered Professional Engineer

1. Support systems, shield systems, and other protective systems not utilizing Option 1, Option 2 or Option 3, above, shall be approved by a registered professional engineer.
2. Designs shall be in written form and shall include the following:
 - a. A plan indicating the sizes, types, and configurations of the materials to be used in the protective system
 - b. A plan identifying the registered professional engineer approving the design
3. At least one copy of the design shall be maintained at the jobsite during construction of the protective system. After that time, the design may be stored off the jobsite, but a copy of the design shall be made available to the Secretary upon request.

MATERIALS AND EQUIPMENT

1. Materials and equipment used for protective systems shall be free from damage or defects that might impair their proper function.
2. Manufactured materials and equipment used for protective systems shall be used and maintained in a manner that is consistent with the recommendations of the manufacturer, and in a manner that will prevent employee exposure to hazards.

3. When material or equipment that is used for protective systems is damaged, a competent person shall examine the material or equipment and evaluate its suitability for continued use. If the competent person cannot assure the material or equipment is able to support the intended loads or is otherwise suitable for safe use, then such material or equipment shall be removed from service, and shall be evaluated and approved by a registered professional engineer before being returned to service.

INSTALLATION AND REMOVAL OF SUPPORT

General

1. Members of support systems shall be securely connected together to prevent sliding, falling, kickouts, or other predictable failure.
2. Support systems shall be installed and removed in a manner that protects employees from cave-ins, structural collapses, or from being struck by members of the support system.
3. Individual members of support systems shall not be subjected to loads exceeding those, which those members were designed to withstand.
4. Before temporary removal of individual members begins, additional precautions shall be taken to ensure the safety of employees, such as installing other structural members to carry the loads imposed on the support system.
5. Removal shall begin at, and progress from, the bottom of the excavation. Members shall be released slowly so as to note any indication of possible failure of the remaining members of the structure or possible cave-in of the sides of the excavation.
6. Backfilling shall progress together with the removal of support systems from excavations.

Support Systems for Trench Excavations

1. Excavation of material to a level no greater than 2 feet (.61 m) below the bottom of the members of a support system shall be permitted, but only if the system is designed to resist the forces calculated for the full depth of the trench, and there are no indications while the trench is open of a possible loss of soil from behind or below the bottom of the support system.
2. Installation of a support system shall be closely coordinated with the excavation of trenches.

Sloping and Benching Systems

Employees shall not be permitted to work on the faces of sloped or benched excavations at levels above other employees except when employees at the lower levels are adequately protected from the hazard of falling, rolling, or sliding material or equipment.

SHIELD SYSTEMS

General

1. Shield systems shall not be subjected to loads exceeding those which the system was designed to withstand.
2. Shields shall be installed in a manner to restrict lateral or other hazardous movement of the shield in the event of the application of sudden lateral loads.

3. Employees shall be protected from the hazard of cave-ins when entering or exiting the areas protected by shields.
4. Employees shall not be allowed in shields when shields are being installed, removed, or moved vertically.

Trench Excavations

Excavations of earth material to a level not greater than 2 feet (.61 m) below the bottom of a shield shall be permitted, but only if the shield is designed to resist the forces calculated for the full depth of the trench, and there are no indications while the trench is open of a possible loss of soil from behind or below the bottom of the shield.

Part 8 Appendix A: Soil Classification

SCOPE AND APPLICATION

Scope

This appendix describes a method of classifying soil and rock deposits based on site and environmental conditions, and on the structure and composition of the earth deposits. The appendix contains definitions, sets forth requirements, and describes acceptable visual and manual tests for use in classifying soils.

Application

This appendix applies when a sloping or benching system is designed in accordance with the requirements set forth in 1926.652(b)(2) as a method of protection for employees from cave-ins. This appendix also applies when timber shoring for excavations is designed as a method of protection from cave-ins in accordance with appendix C to subpart P of part 1926, and when aluminum hydraulic shoring is designed in accordance with appendix D. This Appendix also applies if other protective systems are designed and selected for use from data prepared in accordance with the requirements set forth in 1926.652(c), and the use of the data is predicated on the use of the soil classification system set forth in this appendix.

BASIC TERMINOLOGY

The definitions and examples given below are based on, in whole or in part, the following; American Society for Testing Materials (ASTM) Standards D653-85 and D2488; The Unified Soils Classification System; The U.S. Department of Agriculture (USDA) Textural Classification Scheme; and The National Bureau of Standards Report BSS-121.

CLASSIFICATION OF SOIL AND ROCK DEPOSITS

Each soil and rock deposit shall be classified by a competent person as Stable Rock, Type A, Type B, or Type C in accordance with the definitions set forth in “Basic Terminology” of this appendix.

- **Cemented Soil**
- **Cohesive Soil**
- **Dry Soil**
- **Fissured**
- **Granular Soil**
- **Layered System**
- **Moist Soil**
- **Plastic**
- **Saturated**
- **Soil Classification**
- **Stable Rock**
- **Submerged Soil**
- **Type A**
- **Type B**
- **Type C**
- **Unconfined Compressive Strength**
- **Wet Soil**

Basis of Classification

The classification of the deposits shall be made based on the results of at least one visual and at least one manual analysis. Such analyses shall be conducted by a competent person using tests described in “Acceptable Visual and Manual Tests” below, or in other recognized methods of soil classification and testing such as those adopted by the American Society for Testing Materials, or the U.S. Department of Agriculture textural classification system.

Visual and Manual Analyse

The visual and manual analyses, such as those noted as being acceptable in “Acceptable Visual and Manual Tests” of this appendix, shall be designed and conducted to provide sufficient quantitative and qualitative information as may be necessary to identify properly the properties, factors, and conditions affecting the classification of the deposits.

Layered Systems

In a layered system, the system shall be classified in accordance with its weakest layer. However, each layer may be classified individually where a more stable layer lies under a less stable layer.

Reclassification

If, after classifying a deposit, the properties, factors, or conditions affecting its classification change in any way, the changes shall be evaluated by a competent person. The deposit shall be reclassified as necessary to reflect the changed circumstances.

ACCEPTABLE VISUAL AND MANUAL TESTS

Visual Tests

Visual analysis is conducted to determine qualitative information regarding the excavation site in general, the soil adjacent to the excavation, the soil forming the sides of the open excavation, and the soil taken as samples from excavated material. (i) Observe samples of soil that are excavated and soil in the sides of the

excavation. Estimate the range of particle sizes and the relative amounts of the particle sizes. Soil that is primarily composed of fine-grained material is cohesive material. Soil composed primarily of coarse-grained sand or gravel is granular material.

1. Observe soil as it is excavated. Soil that remains in clumps when excavated is cohesive. Soil that breaks up easily and does not stay in clumps is granular.
2. Observe the side of the opened excavation and the surface area adjacent to the excavation. Crack-like openings such as tension cracks could indicate fissured material. If chunks of soil spall off a vertical side, the soil could be fissured. Small spalls are evidence of moving ground and are indications of potentially hazardous situations.
3. Observe the area adjacent to the excavation and the excavation itself for evidence of existing utility and other underground structures, and to identify previously disturbed soil.
4. Observed the opened side of the excavation to identify layered systems. Examine layered systems to identify if the layers slope toward the excavation. Estimate the degree of slope of the layers.
5. Observe the area adjacent to the excavation and the sides of the opened excavation for of surface water, water seeping from the sides of the excavation, or the location of the level of the water table.
6. Observe the area adjacent to the excavation and the area within the excavation for sources of vibration that may affect the stability of the excavation face.

Manual Tests

1. Manual analysis of soil samples is conducted to determine quantitative as well as qualitative properties of soil and to provide more information in order to classify soil properly.
2. Plasticity. Mold a moist or wet sample of soil into a ball and attempt to roll it into threads as thin as 1/8-inch in diameter. Cohesive material can be successfully rolled into threads without crumbling.



Example: If at least a two-inch (50 mm) length of 1/8-inch thread can be held on one end without tearing, the soil is cohesive.

3. Dry strength. If the soil is dry and crumbles on its own or with moderate pressure into individual grains or fine powder, it is granular (any combination of gravel, sand, or silt). If the soil is dry and falls into clumps, which break up into smaller clumps, but the smaller clumps can only be broken up with difficulty, it may be clay in any combination with gravel, sand or silt. If the dry soil breaks into clumps which do not break up into small clumps and which can only be broken with difficulty, and there is no visual indication the soil is fissured, the soil may be considered unfissured.
4. Thumb penetration. The thumb penetration test can be used to estimate the unconfined compressive strength of cohesive soils. (This test is based on the thumb penetration test described in American Society for Testing and Materials (ASTM) Standard designation D2488 - "Standard Recommended Practice for Description of Soils (Visual - Manual Procedure).") Type A soils with an unconfined compressive strength of 1.5 tsf can be readily indented by the thumb; however, they can be penetrated by the thumb only with very great effort. Type C soils with an unconfined compressive strength of 0.5 tsf can be easily penetrated several inches by the thumb, and can be molded by light finger pressure. This test should be conducted on an undisturbed soil sample, such as a large clump of spoil, as soon as practicable after excavation to keep to a minimum the effects of exposure to drying influences. If the excavation is later exposed to wetting influences (rain, flooding), the classification of the soil must be changed accordingly.
5. Other strength tests. Estimates of unconfined compressive strength of soils can also be obtained by use of a pocket penetrometer or by using a hand-operated shear vane.

6. Drying test. The basic purpose of the drying test is to differentiate between cohesive material with fissures, unfissured cohesive material, and granular material. The procedure for the drying test involves drying a sample of soil that is approximately one inch thick (2.54 cm) and six inches (15.24 cm) in diameter until it is thoroughly dry:
 - a. If the sample develops cracks as it dries, significant fissures are indicated.
 - b. Samples that dry without cracking are to be broken by hand. If considerable force is necessary to break a sample, the soil has significant cohesive material content. The soil can be classified as an unfissured cohesive material and the unconfined compressive strength should be determined.
 - c. If a sample breaks easily by hand, it is either a fissured cohesive material or a granular material. To distinguish between the two, pulverize the dried clumps of the sample by hand or by stepping on them. If the clumps do not pulverize easily, the material is cohesive with fissures. If they pulverize easily into very small fragments, the material is granular.

Part 8 Appendix B: Sloping & Benching

SCOPE AND APPLICATION

This appendix contains specifications for sloping and benching when used as methods of protecting employees working in excavations from cave-ins. The requirements of this appendix apply when the design of sloping and benching protective systems is to be performed in accordance with the requirements set forth in this Safety Program under Design of sloping and benching systems Option (2) – Determining Slopes and Configurations.

BASIC TERMINOLOGY

Definitions for the following terms are listed alphabetically within the Glossary located at the back of this publication:

- **Actual Slope**
- **Distress**
- **Maximum Allowable Slope**
- **Short Term Exposure**
- **Soil Classification**
- **Maximum Allowable Slope**

SOIL CLASSIFICATION REQUIREMENTS

1. Soil and rock deposits shall be classified in accordance with Appendix A.
2. Maximum allowable slope. The maximum allowable slope for a soil or rock deposit shall be determined from Table B-1 of this appendix.
3. Actual slope:
 - a. The actual slope shall not be steeper than the maximum allowable slope.
 - b. The actual slope shall be less steep than the maximum allowable slope, when there are signs of distress. If that situation occurs, the slope shall be cut back to an actual slope, which is at least $\frac{1}{2}$ horizontal to one vertical (1/2H:1V) less steep than the maximum allowable slope.
 - c. When surcharge loads from stored material or equipment, operating equipment, or traffic are present, a competent person shall determine the degree to which the actual slope must be reduced below the maximum allowable slope, and shall assure that such reduction is achieved. Surcharge loads from adjacent structures shall be evaluated in accordance with the requirements set forth in this Safety Program under *Stability of adjacent structures*.

SHOPE CONFIGURATIONS

Configurations of sloping and benching systems shall be in accordance with Figure B-1.

Maximum Allowable Slopes	
Soil/Rock Type	Maximum Allowable Slopes (H:V)(1) Excavations Less Than 20 Feet Deep(3)
Stable Rock	Vertical (90 Deg.)
Type A (2)	3/4:1 (53 Deg.)
Type B	1:1 (45 Deg.)
Type C	1 1/2:1 (34 Deg.)

Note: Numbers shown in parentheses next to maximum allowable slopes are angles expressed in degrees from the horizontal. Angles have been rounded off.

A short-term maximum allowable slope of 1/2H:1V (63 degrees) is allowed in excavations in Type A soil that are 12 feet (3.67 m) or less in depth. Short-term maximum allowable slopes for excavations greater than 12 feet (3.67 m) in depth shall be 3/4H:1V (53 degrees).

Sloping or benching for excavations greater than 20 feet deep shall be designed by a registered professional engineer.

Table 4: Maximum Allowable Slopes

B – 1.1 EXCAVATIONS MADE IN TYPE A SOIL

All slopes stated below are in the horizontal to vertical ratio

General Simple Slope

All simple slope excavation 20 feet or less in depth shall have a maximum allowable slope of 3/4:1.

Figure 1: General Simple Slope

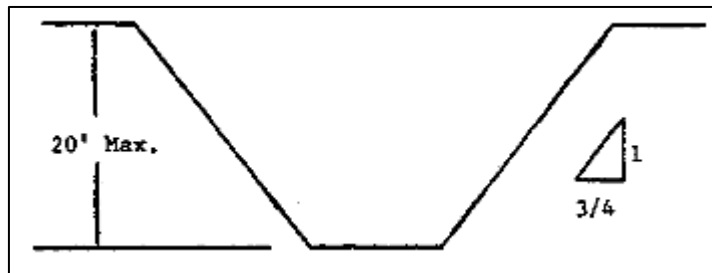

Exception: Simple slope excavations, which are open 24 hours or less (short term) and which are 12 feet or less in depth shall have a maximum allowable slope of 1/2:1.

Figure 2: Simple Slope - Short Term

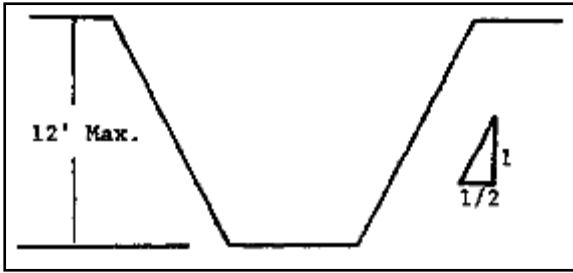

All benched excavations 20 feet or less in depth shall have a maximum allowable slope of 3/4 to 1 and maximum bench dimensions as follows:

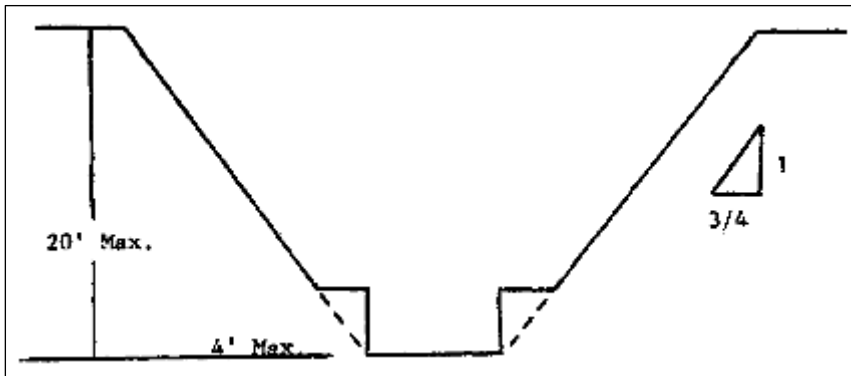
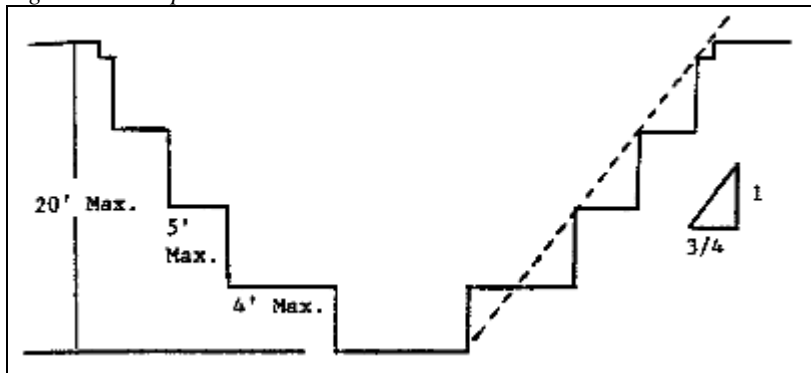

Figure 3: Simple Bench

Figure 4: Multiple Benches



All excavations 8 feet or less in depth which have unsupported vertically sided lower portions shall have a maximum vertical side of 3 1/2 feet.

Figure 5: Unsupported Vertically Sided Lower Portion - Maximum 8 Feet in Depth

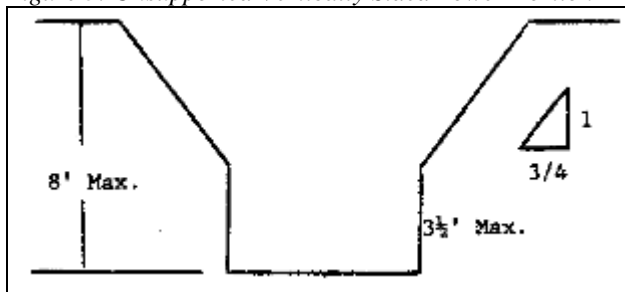

All excavations more than 8 feet but not more than 12 feet in depth with unsupported vertically sided lower portions shall have a maximum allowable slope of 1:1 and a maximum vertical side of 3 1/2 feet.

Figure 6: Unsupported Vertically Sided Lower Portion - Maximum 12 Feet in Depth

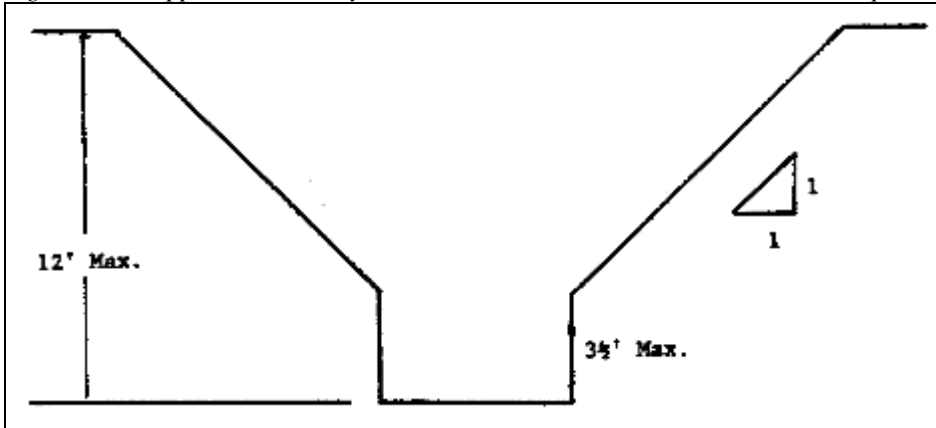

All excavations 20 feet or less in depth which have vertically sided lower portions that are supported or shielded shall have a maximum allowable slope of 3/4:1. The support or shield system must extend at least 18 inches above the top of the vertical side.

Figure 7: Supported or Shielded Vertically Sided Lower Portion

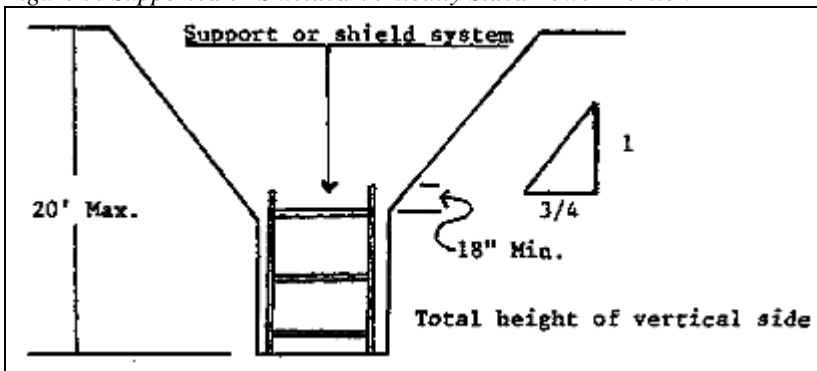

All other simple slope, compound slope, and vertically sided lower portion excavations shall be in accordance with the other options permitted in this section.

B - 1.2 EXCAVATIONS MADE IN TYPE B SOIL

All simple slope excavations 20 feet or less in depth shall have a maximum allowable slope of 1:1.

Figure 8: Simple Slope

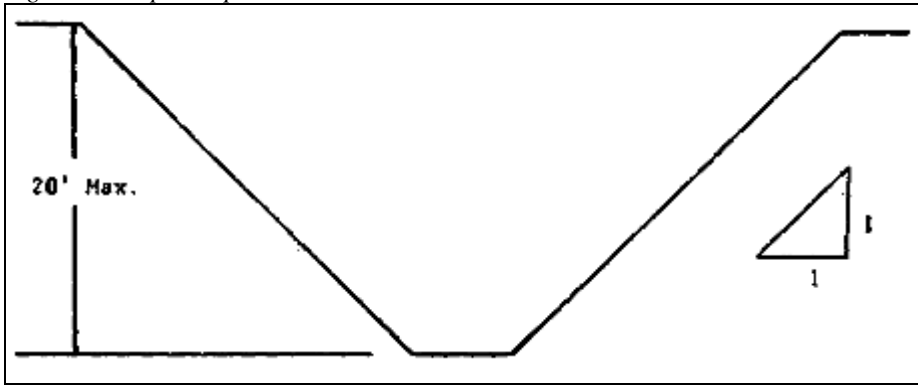

All benched excavations 20 feet or less in depth shall have a maximum allowable slope of 1:1 and maximum bench dimensions as follows:

Figure 9: Single Bench

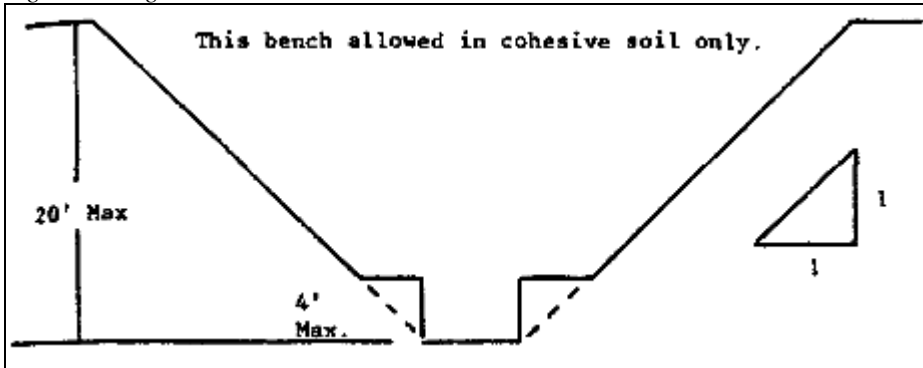
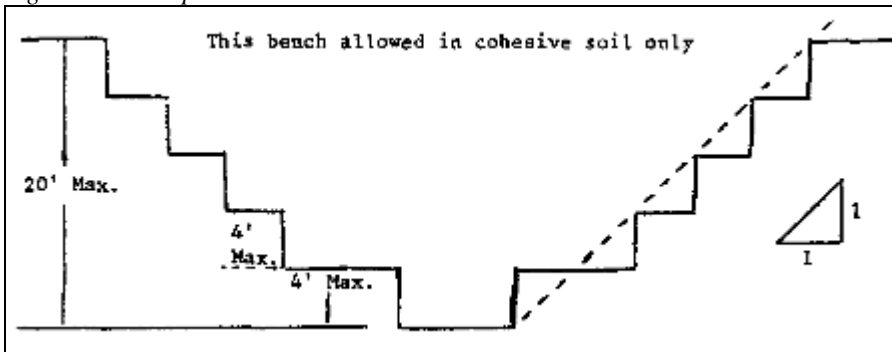
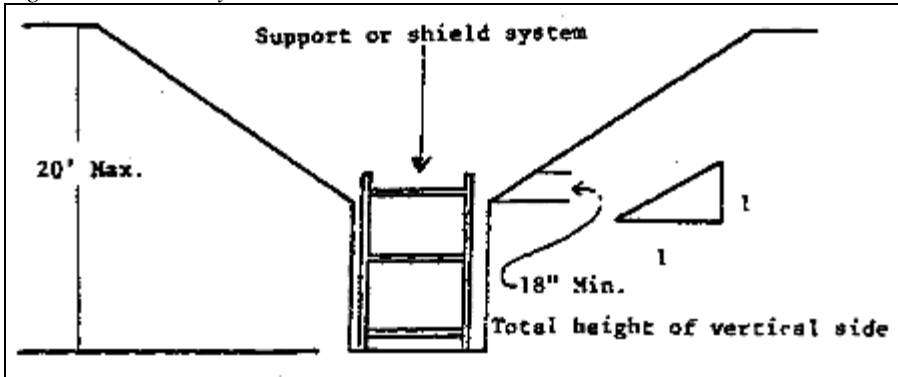

Figure 10: Multiple Benches



All excavations 20 feet or less in depth which have vertically sided lower portions shall be shielded or supported to a height at least 18 inches above the top of the vertical side. All such excavations shall have a maximum allowable slope of 1:1.

Figure 11: Vertically Sided Lower Portion



All other sloped excavations shall be in accordance with the other options permitted in this section.

B - 1.3 EXCAVATIONS MADE IN TYPE C SOIL

All simple slope excavations 20 feet or less in depth shall have a maximum allowable slope of 1 1/2:1.

Figure 12: Simple Slope

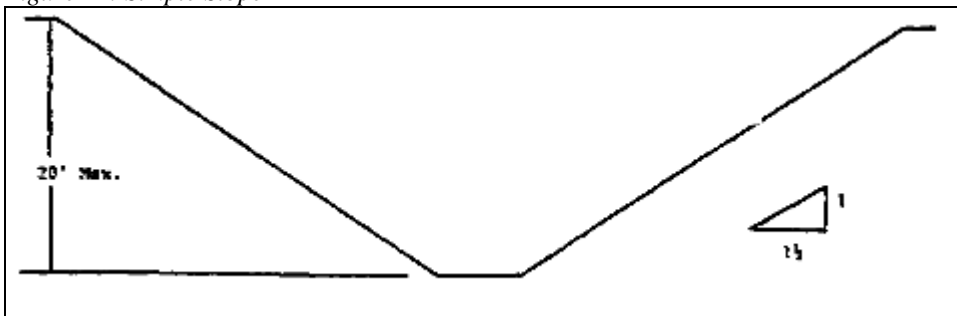

All excavations 20 feet or less in depth which have vertically sided lower portions shall be shielded or supported to a height at least 18 inches above the top of the vertical side. All such excavations shall have a maximum allowable slope of 1 1/2:1.

Figure 13: Vertical Sided Lower Portion

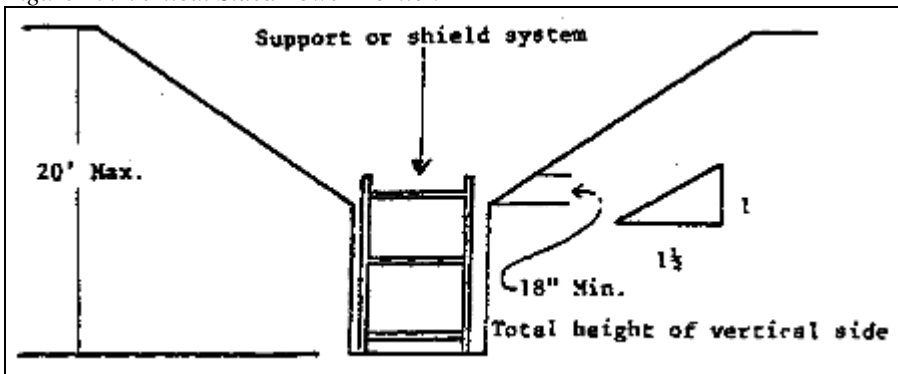

All other sloped excavations shall be in accordance with the other options permitted in this section

B - 1.4 EXCAVATIONS MADE IN LAYERED SOILS

All excavations 20 feet or less in depth made in layered soils shall have a maximum allowable slope for each layer as set forth below.

Figure 14: B Over A

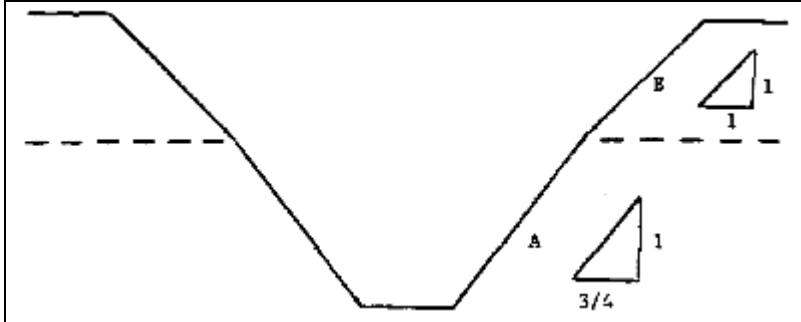

Figure 15: C Over A

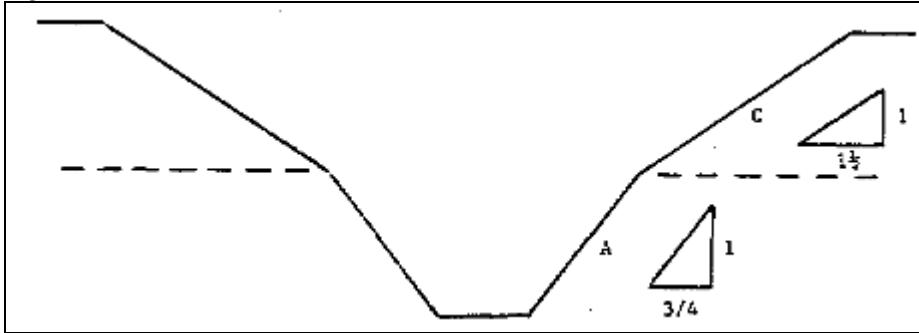

Figure 16: C Over B

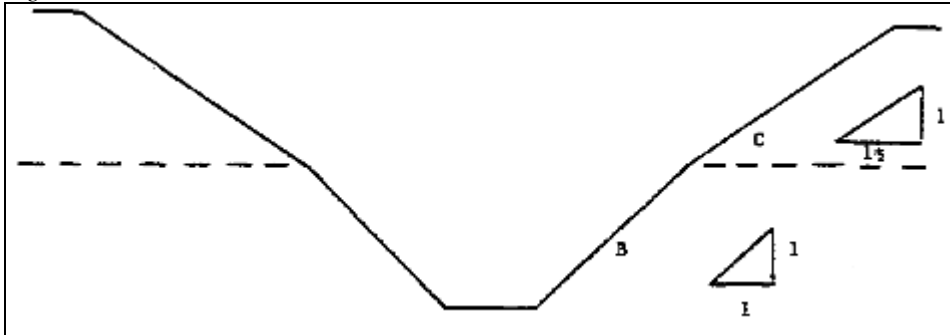

Figure 17: A Over B

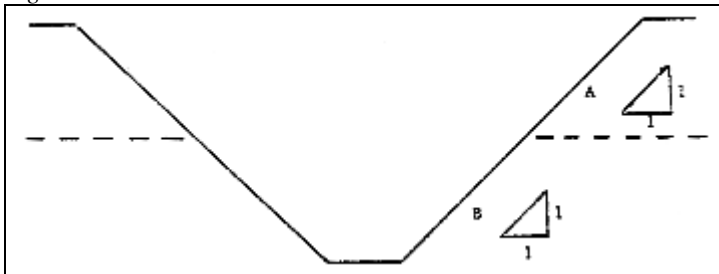

Figure 18: A Over C

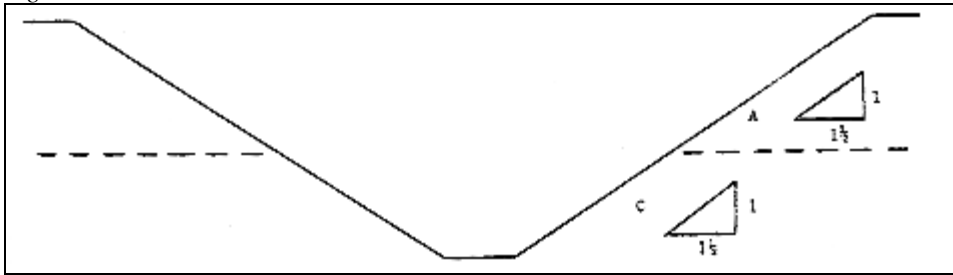
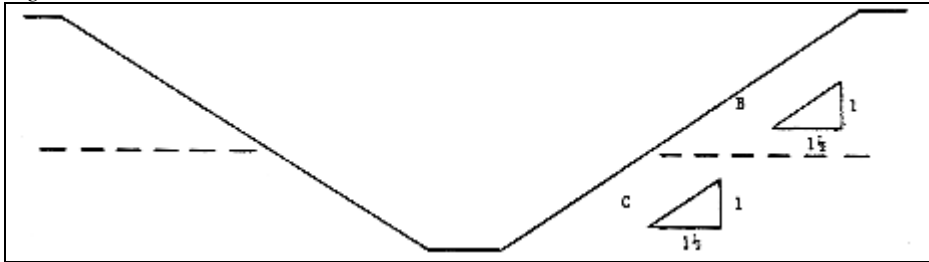

Figure 19: B Over C



All other sloped excavations shall be in accordance with the other options permitted in this section.

Part 8 Appendix C:

Timber Shoring for Trenches

SCOPE

This appendix contains information that can be used when timber shoring is provided as a method of protection from cave-ins in trenches that do not exceed 20 feet (6.1 m) in depth. This appendix must be used when design of timber shoring protective systems is to be performed in accordance with this section. Other timber shoring configurations; other systems of support such as hydraulic and pneumatic systems; and other protective systems such as sloping, benching, shielding, and freezing systems must be designed in accordance with the requirements set forth in this section.

SOIL CLASSIFICATION

In order to use the data presented in this appendix, the soil type or types in which the excavation is made must first be determined using the soil classification method set forth in appendix A of this part.

PRESENTATION OF INFORMATION

Information is presented in several forms as follows:

1. Information is presented in tabular form in Tables C-1.1, C-1.2 and C-1.3, and Tables C-2.1, C-2.2 and C-2.3 following paragraph (g) of the appendix. Each table presents the minimum sizes of timber members to use in a shoring system, and each table contains data only for the particular soil type in which the excavation or portion of the excavation is made. The data are arranged to allow the user the flexibility to select from among several acceptable configurations of members based on varying the horizontal spacing of the cross braces. Stable rock is exempt from shoring requirements and therefore, no data are presented for this condition.
2. Information concerning the basis of the tabular data and the limitations of the data is presented in paragraph (d) of this appendix, and on the tables themselves.
3. Information explaining the use of the tabular data is presented in paragraph (e) of this appendix.
4. Information illustrating the use of the tabular data is presented in paragraph (f) of this appendix.
5. Miscellaneous notations regarding Tables C-1.1 through C-1.3 and Tables C-2.1 through C-2.3 are presented in paragraph (g) of this Appendix.

BASIS AND LIMITATIONS OF THE DATA

Dimensions of Timber Members

1. The sizes of the timber members listed in Tables C-1.1 through C-1.3 are taken from the National Bureau of Standards (NBS) report, "Recommended Technical Provisions for Construction Practice in Shoring and Sloping of Trenches and Excavations." In addition, where NBS did not recommend specific sizes of members, member sizes are based on an analysis of the sizes required for use by existing codes and on empirical practice.
2. The required dimensions of the members listed in Tables C-1.1 through C-1.3 refer to actual dimensions and not nominal dimensions of the timber. Employers wanting to use nominal size shoring are directed to Tables C-2.1 through C-2.3, and are referred to The Corps of engineers, The Bureau of Reclamation or data from other acceptable sources.

Limitation of application

1. It is not intended that the timber shoring specification apply to every situation that may be experienced in the field. These data were developed to apply to the situations that are most commonly experienced in current trenching practice. Shoring systems for use in situations that are not covered by the data in this appendix must be designed as specified in this section.
2. When any of the following conditions are present, the members specified in the tables are not considered adequate. Either an alternate timber shoring system must be designed or another type of protective system designed in accordance with this section.
 - a. When loads imposed by structures or by stored material adjacent to the trench weigh in excess of the load imposed by a two-foot soil surcharge. The term "adjacent" as used here means the area within a horizontal distance from the edge of the trench equal to the depth of the trench.
 - b. When vertical loads imposed on cross braces exceed a 240-pound gravity load distributed on a one-foot section of the center of the cross brace.
 - c. When surcharge loads are present from equipment weighing in excess of 20,000 pounds.
 - d. When only the lower portion of a trench is shored and the remaining portion of the trench is sloped or benched unless: The sloped portion is sloped at an angle less steep than three horizontal to one vertical; or the members are selected from the tables for use at a depth which is determined from the top of the overall trench, and not from the toe of the sloped portion.

USE OF TABLES

The members of the shoring system that are to be selected using this information are the cross braces, the uprights, and the wales, where wales are required. Minimum sizes of members are specified for use in different types of soil. There are six tables of information, two for each soil type. The soil type must first be determined in accordance with the soil classification system described in appendix A of this section. Using the appropriate table, the selection of the size and spacing of the members is then made. The selection is based on the depth and width of the trench where the members are to be installed and, in most instances, the selection is also based on the horizontal spacing of the cross braces. Instances where a choice of horizontal spacing of cross bracing is available, the horizontal spacing of the cross braces must be chosen by the user before the size of any member can be determined. When the soil type, the width and depth of the trench, and the horizontal spacing of the cross braces are known, the size and vertical spacing of the cross braces are known, the size and vertical spacing of the cross braces, the size and vertical spacing of the wales, and the size and horizontal spacing of the uprights can be read from the appropriate table.

EXAMPLES TO ILLUSTRATE THE USE OF TABLES C-1.1 THROUGH C-1.3.

Example 1

A trench dug in Type A soil is 13 feet deep and five feet wide. From Table C-1.1, for acceptable arrangements of timber can be used.

Arrangement 1

1. Space 4X4 cross braces at six feet horizontally and four feet vertically.
2. Wales are not required.
3. Space 3X8 uprights at six feet horizontally. This arrangement is commonly called "skip shoring."

Arrangement 2

1. Space 4X6 cross braces at eight feet horizontally and four feet vertically.
2. Space 8X8 wales at four feet vertically.
3. Space 2X6 uprights at four feet horizontally.

Arrangement 3

1. Space 6X6 cross braces at 10 feet horizontally and four feet vertically.
2. Space 8X10 wales at four feet vertically.
3. Space 2X6 uprights at five feet horizontally.

Arrangement 4

1. Space 6X6 cross braces at 12 feet horizontally and four feet vertically.
2. Space 10X10 wales at four feet vertically.
3. Space 3X8 uprights at six feet horizontally.

Example 2

A trench dug in Type B soil is 13 feet deep and five feet wide. From Table C-1.2 three acceptable arrangements of members are listed.

Arrangement 1

1. Space 6X6 cross braces at six feet horizontally and five feet vertically.
2. Space 8X8 wales at five feet vertically.
3. Space 2X6 uprights at two feet horizontally.

Arrangement 2

1. Space 6X8 cross braces at eight feet horizontally and five feet vertically.
2. Space 10X10 wales at five feet vertically.
3. Space 2X6 uprights at two feet horizontally.

Arrangement 3

1. Space 8X8 cross braces at 10 feet horizontally and five feet vertically.
2. Space 10X12 wales at five feet vertically.
3. Space 2X6 uprights at two feet vertically.

Example 3

A trench dug in Type C soil is 13 feet deep and five feet wide. From Table C-1.3 two acceptable arrangements of members can be used.

Arrangement 1

1. Space 8X8 cross braces at six feet horizontally and five feet vertically.
2. Space 10X12 wales at five feet vertically.
3. Position 2X6 uprights as closely together as possible.
4. If water must be retained use special tongue and groove uprights to form tight sheeting.

Arrangement 2

1. Space 8X10 cross braces at eight feet horizontally and five feet vertically.
2. Space 12X12 wales at five feet vertically.
3. Position 2X6 uprights in a close sheeting configuration unless water pressure must be resisted. Tight sheeting must be used where water must be retained.

Example 4

A trench dug in Type C soil is 20 feet deep and 11 feet wide. The size and spacing of members for the section of trench that is over 15 feet in depth is determined using Table C-1.3. Only one arrangement of members is provided.

1. Space 8X10 cross braces at six feet horizontally and five feet vertically.
2. Space 12X12 wales at five feet vertically.
3. Use 3X6 tight sheeting.
4. Use of Tables C-2.1 through C-2.3 would follow the same procedures.

NOTES FOR ALL TABLES

1. Member sizes at spacings other than indicated are to be determined as specified in 1926.652(c), "Design of Protective Systems."
2. When conditions are saturated or submerged use Tight Sheeting. Tight Sheeting refers to the use of specially-edged timber planks (e.g., tongue and groove) at least three inches thick, steel sheet piling, or similar construction that when driven or placed in position provide a tight wall to resist the lateral pressure of water and to prevent the loss of backfill material. Close Sheeting refers to the placement of planks side-by-side allowing as little space as possible between them.
3. All spacing indicated is measured center to center.
4. Wales to be installed with greater dimension horizontal.
5. If the vertical distance from the center of the lowest cross brace to the bottom of the trench exceeds two and one-half feet, uprights shall be firmly embedded or a mudsill shall be used.

Where uprights are embedded, the vertical distance from the center of the lowest cross brace to the bottom of the trench shall not exceed 36 inches. When mudsills are used, the vertical distance shall not exceed 42 inches. Mudsills are wales that are installed at the top of the trench side.

6. Trench jacks may be used in lieu of or in combination with timber cross braces.
7. Placement of cross braces. When the vertical spacing of cross braces is four feet, place the top cross brace no more than two feet below the top of the trench. When the vertical spacing of cross braces is five feet, place the top cross brace no more than 2.5 feet below the top of the trench.

TABLE C-1.1

Timber Trench Shoring							
Minimum Timber Requirements* Soil Type A $P(a) = 25 \times H + 72$ psf (2 ft Surcharge)							
Depth of Trench (Feet)	Size (Actual) and Spacing of Members**						
	Horz. Spacing (Feet)	CROSS BRACES					Vert. Spacing (Feet)
		Width of Trench (Feet)					
		Up to 4	Up to 6	Up to 9	Up to 12	Up to 15	
5 x 10	Up to 6	4 x 4	4 x 4	4 x 6	6 x 6	6 x 6	4
	Up to 8	4 x 4	4 x 4	4 x 6	6 x 6	6 x 6	4
	Up to 10	4 x 6	4 x 6	4 x 6	6 x 6	6 x 6	4
	Up to 12	4 x 6	4 x 6	6 x 6	6 x 6	6 x 6	4
10 x 15	Up to 6	4 x 4	4 x 4	4 x 6	6 x 6	6 x 6	4
	Up to 8	4 x 6	4 x 6	6 x 6	6 x 6	6 x 6	4
	Up to 10	6 x 6	6 x 6	6 x 6	6 x 8	6 x 8	4
	Up to 12	6 x 6	6 x 6	6 x 6	6 x 8	6 x 8	4
15 x 20	Up to 6	6 x 6	6 x 6	6 x 6	6 x 8	6 x 8	4
	Up to 8	6 x 6	6 x 6	6 x 6	6 x 8	6 x 8	4
	Up to 10	8 x 8	8 x 8	8 x 8	8 x 8	8 x 10	4
	Up to 12	8 x 8	8 x 8	8 x 8	8 x 8	8 x 10	4
Over 20	See Note 1						

* Mixed oak or equivalent with a bending strength not less than 850 psi.
 ** Manufactured members of equivalent strength may be substituted for wood.

Timber Trench Shoring						
Minimum Timber Requirements* Soil Type A $P(a) = 25 \times H + 72$ psf (2 ft Surcharge)						
Depth of Trench (Feet)	Size (Actual) and Spacing of Members**					
	WALES		UPRIGHTS			
	Size (In)	Vert. Spacing (Feet)	Maximum Allowable Horizontal Spacing (Feet)			
			Close	4	5	6
5 x 10	Not Req.	Not Req.	2 x 6			
	Not Req.	Not Req.	2 x 8			
	8 x 8	4	2 x 6			
	8 x 8	4	2 x 6			
10 x 15	Not Req.	Not Req.	3 x 8			
	8 x 8	4	2 x 6			
	8 x 10	4	2 x 6			
	10 x 10	4	3 x 8			
15 x 20	6 x 8	4	3 x 6			
	8 x 8	4	3 x 6			
	8 x 10	4	3 x 6			
	10 x 10	4	3 x 6			
Over 20	See Note 1					

* Mixed oak or equivalent with a bending strength not less than 850 psi.

** Manufactured members of equivalent strength may be substituted for wood.

Table 5: C-1.1

TABLE C-1.2

Timber Trench Shoring							
Minimum Timber Requirements* Soil Type B $P(a) = 45 X H + 72$ psf (2 ft Surcharge)							
Depth of Trench (Feet)	Size (Actual) and Spacing of Members**						
	Horz. Spacing (Feet)	CROSS BRACES					Vert. Spacing (Feet)
		Width of Trench (Feet)					
		Up to 4	Up to 6	Up to 9	Up to 12	Up to 15	
5 x 10	Up to 6	4 x 4	4 x 4	6 x 6	6 x 6	6 x 6	5
	Up to 8	6 x 6	6 x 6	6 x 6	6 x 8	6 x 8	5
	Up to 10	6 x 6	6 x 6	6 x 6	6 x 8	6 x 8	5
	See Note 1						
10 x 15	Up to 6	6 x 6	6 x 6	6 x 6	6 x 8	6 x 8	5
	Up to 8	6 x 8	6 x 8	6 x 8	8 x 8	8 x 8	5
	Up to 10	8 x 8	8 x 8	8 x 8	8 x 8	8 x 10	5
	See Note 1						
15 x 20	Up to 6	6 x 8	6 x 8	6 x 8	8 x 8	8 x 8	5
	Up to 8	8 x 8	8 x 8	8 x 8	8 x 8	8 x 10	5
	Up to 10	8 x 10	8 x 10	8 x 10	8 x 10	10 x 10	5
	See Note 1						
Over 20	See Note 1						

* Mixed oak or equivalent with a bending strength not less than 850 psi.

** Manufactured members of equivalent strength may be substituted for wood.

Timber Trench Shoring					
Minimum Timber Requirements* Soil Type B $P(a) = 45 X H + 72$ psf (2 ft Surcharge)					
Depth of Trench (Feet)	Size (Actual) and Spacing of Members**				
	WALES		UPRIGHTS		
	Size (In)	Vert. Spacing (Feet)	Maximum Allowable Horizontal Spacing (Feet)		
			Close	2	3
	6 x 8	5			2 x 6
5 x 10	8 x 10	5			2 x 6
	10 x 10	5			2 x 6
	8 x 8	5		2 x 6	
10 x 15	10 x 10	5		2 x 6	
	10 x 12	5		2 x 6	
	8 x 10	5	3 x 6		
15 x 20	10 x 12	5	3 x 6		
	12 x 12	5	3 x 6		
Over 20	See Note 1				

* Mixed oak or equivalent with a bending strength not less than 850 psi.

** Manufactured members of equivalent strength may be substituted for wood.

Table 6: C-1.2

TABLE C-1.3

Timber Trench Shoring							
Minimum Timber Requirements* Soil Type C $P(a) = 80 \times H + 72$ psf (2 ft Surcharge)							
Depth of Trench (Feet)	Size (Actual) and Spacing of Members**						
	CROSS BRACES						
	Horz. Spacing (Feet)	Width of Trench (Feet)					Vert. Spacing (Feet)
Up to 4		Up to 6	Up to 9	Up to 12	Up to 15		
5 x 10	Up to 6	6 x 8	6 x 8	6 x 8	8 x 8	8 x 8	5
	Up to 8	8 x 8	8 x 8	8 x 8	8 x 8	8 x 10	5
	Up to 10	8 x 10	8 x 10	8 x 10	8 x 10	10 x 10	5
	See Note 1						
10 x 15	Up to 6	8 x 8	8 x 8	8 x 8	8 x 8	8 x 10	5
	Up to 8	8 x 10	8 x 10	8 x 10	8 x 10	10 x 10	5
	See Note 1						
15 x 20	Up to 6	8 x 10	8 x 10	8 x 10	8 x 10	10 x 10	5
	See Note 1						
Over 20	See Note 1						

* Mixed oak or equivalent with a bending strength not less than 850 psi.

** Manufactured members of equivalent strength may be substituted for wood.

Timber Trench Shoring			
Minimum Timber Requirements* Soil Type C P(a) = 80 X H + 72 psf (2 ft Surcharge)			
Depth of Trench (Feet)	Size (Actual) and Spacing of Members**		
	WALES		UPRIGHTS
	Size (In)	Vert. Spacing (Feet)	Maximum Allowable Horizontal Spacing (Feet) Close
	8 x 10	5	2 x 6
5 x 10	10 x 12	5	2 x 6
	12 x 12	5	2 x 6
10 x 15	10 x 12	5	2 x 6
	12 x 12	5	2 x 6
15 x 20	12 x 12	5	3 x 6
Over 20	See Note 1		

* Mixed oak or equivalent with a bending strength not less than 850 psi.

** Manufactured members of equivalent strength may be substituted for wood.

Table 7: C-1.3

TABLE C-2.1

Timber Trench Shoring							
Minimum Timber Requirements* Soil Type A $P(a) = 25 X H + 72$ psf (2 ft Surcharge)							
Depth of Trench (Feet)	Size (S4S) and Spacing of Members**						
	Horz. Spacing (Feet)	CROSS BRACES					Vert. Spacing (Feet)
		Width of Trench (Feet)					
		Up to 4	Up to 6	Up to 9	Up to 12	Up to 15	
5 x 10	Up to 6	4 x 4	4 x 4	4 x 4	4 x 4	4 x 6	4
	Up to 8	4 x 4	4 x 4	4 x 4	4 x 6	4 x 6	4
	Up to 10	4 x 6	4 x 6	4 x 6	6 x 6	6 x 6	4
	Up to 12	4 x 6	4 x 6	4 x 6	6 x 6	6 x 6	4
10 x 15	Up to 6	4 x 4	4 x 4	4 x 4	6 x 6	6 x 6	4
	Up to 8	4 x 6	4 x 6	4 x 6	6 x 6	6 x 6	4
	Up to 10	6 x 6	6 x 6	6 x 6	6 x 6	6 x 6	4
	Up to 12	6 x 6	6 x 6	6 x 6	6 x 6	6 x 6	4
15 x 20	Up to 6	6 x 6	6 x 6	6 x 6	6 x 6	6 x 6	4
	Up to 8	6 x 6	6 x 6	6 x 6	6 x 6	6 x 6	4
	Up to 10	6 x 6	6 x 6	6 x 6	6 x 6	6 x 8	4
	Up to 12	6 x 6	6 x 6	6 x 6	6 x 8	6 x 8	4
Over 20	See Note 1						

* Douglas fir or equivalent with a bending strength not less than 1500 psi.

** Manufactured members of equivalent strength may be substituted for wood.

Timber Trench Shoring						
Minimum Timber Requirements* Soil Type A $P(a) = 25 \times H + 72$ psf (2 ft Surcharge)						
Depth of Trench (Feet)	Size (S4S) and Spacing of Members**					
	WALES		UPRIGHTS			
	Size (In)	Vert. Spacing (Feet)	Maximum Allowable Horizontal Spacing (Feet)			
			Close	4	5	6
5 x 10	Not Req.	Not Req.	4 x 6			
	Not Req.	Not Req.	4 x 8			
	8 x 8	4	4 x 6			
	8 x 8	4	4 x 6			
10 x 15	Not Req.	Not Req.	4 x 10			
	6 x 8	4	4 x 6			
	8 x 8	4	4 x 8			
	8 x 10	4	4 x 6			
15 x 20	6 x 8	4	3 x 6			
	8 x 8	4	3 x 6			
	8 x 10	4	3 x 6			
	8 x 12	4	3 x 6			
Over 20	See Note 1					

* Douglas fir or equivalent with a bending strength not less than 1500 psi.

** Manufactured members of equivalent strength may be substituted for wood.

Table 8: C-2.1

TABLE C-2.2

Timber Trench Shoring							
Minimum Timber Requirements* Soil Type B $P(a) = 45 X H + 72$ psf (2 ft Surcharge)							
Depth of Trench (Feet)	Size (S4S) and Spacing of Members**						
	Horz. Spacing (Feet)	Width of Trench (Feet)					Vert. Spacing (Feet)
		Up to 4	Up to 6	Up to 9	Up to 12	Up to 15	
5 x 10	Up to 6	4 x 6	4 x 6	4 x 6	6 x 6	6 x 6	5
	Up to 8	4 x 6	4 x 6	6 x 6	6 x 6	6 x 6	5
	Up to 10	4 x 6	4 x 6	6 x 6	6 x 6	6 x 8	5
	See Note 1						
10 x 15	Up to 6	6 x 6	6 x 6	6 x 6	6 x 8	6 x 8	5
	Up to 8	6 x 8	6 x 8	6 x 8	8 x 8	8 x 8	5
	Up to 10	6 x 8	6 x 8	8 x 8	8 x 8	8 x 8	5
	See Note 1						
15 x 20	Up to 6	6 x 8	6 x 8	6 x 8	6 x 8	8 x 8	5
	Up to 8	6 x 8	6 x 8	6 x 8	8 x 8	8 x 8	5
	Up to 10	8 x 8	8 x 8	8 x 8	8 x 8	8 x 8	5
	See Note 1						
Over 20	See Note 1						

* Douglas fir or equivalent with a bending strength not less than 1500 psi.
 ** Manufactured members of equivalent strength may be substituted for wood.

Timber Trench Shoring						
Minimum Timber Requirements* Soil Type B $P(a) = 45 X H + 72$ psf (2 ft Surcharge)						
Depth of Trench (Feet)	Size (S4S) and Spacing of Members**					
	WALES		UPRIGHTS			
	Size (In)	Vert. Spacing (Feet)	Maximum Allowable Horizontal Spacing (Feet)			
Close			2	3		
5 x 10	6 x 8	5			3 x 12	4 x 12
					4 x 8	
	8 x 8	5		3 x 8		4 x 8
10 x 15	8 x 10	5			4 x 8	
	8 x 8	5	3 x 6	4 x 10		
	10 x 10	5	3 x 6	4 x 10		
15 x 20	12 x 12	5	3 x 6	4 x 10		
	8 x 10	5	4 x 6			
	10 x 12	5	4 x 6			
Over 20	12 x 12	5	4 x 6			
	See Note 1					

* Douglas fir or equivalent with a bending strength not less than 1500 psi.

** Manufactured members of equivalent strength may be substituted for wood.

Table 9: C-2.2

TABLE C-2.3

Timber Trench Shoring							
Minimum Timber Requirements* Soil Type C $P(a) = 80 X H + 72$ psf (2 ft Surcharge)							
Depth of Trench (Feet)	Size (S4S) and Spacing of Members**						
	CROSS BRACES						
	Horz. Spacing (Feet)	Width of Trench (Feet)					Vert. Spacing (Feet)
Up to 4		Up to 6	Up to 9	Up to 12	Up to 15		
5 x 10	Up to 6	6 x 6	6 x 6	6 x 6	6 x 6	8 x 8	5
	Up to 8	6 x 6	6 x 6	6 x 6	8 x 8	8 x 8	5
	Up to 10	6 x 6	6 x 6	8 x 8	8 x 8	8 x 8	5
	See Note 1						
10 x 15	Up to 6	6 x 8	6 x 8	6 x 8	8 x 8	8 x 8	5
	Up to 8	8 x 8	8 x 8	8 x 8	8 x 8	8 x 8	5
	See Note 1						
15 x 20	Up to 6	8 x 8	8 x 8	8 x 8	8 x 10	10 x 10	5
	See Note 1						
Over 20	See Note 1						

* Douglas fir or equivalent with a bending strength not less than 1500 psi.

** Manufactured members of equivalent strength may be substituted for wood.

Timber Trench Shoring			
Minimum Timber Requirements* Soil Type C P(a) = 80 X H + 72 psf (2 ft Surcharge)			
Depth of Trench (Feet)	Size (S4S) and Spacing of Members**		
	WALES		UPRIGHTS
	Size (In)	Vert. Spacing (Feet)	Maximum Allowable Horizontal Spacing (Feet) Close
	8 x 10	5	3 x 6
5 x 10	10 x 10	5	3 x 6
	10 x 12	5	3 x 6
10 x 15	10 x 10	5	4 x 6
	12 x 12	5	4 x 6
15 x 20	10 x 12	5	4 x 6
Over 20	See Note 1		

* Douglas fir or equivalent with a bending strength not less than 1500 psi.

** Manufactured members of equivalent strength may be substituted for wood.

Table 10: C-2.3

Part 8 Appendix D:

Aluminum Hydraulic Shoring for Trenches

SCOPE

This appendix contains information that can be used when aluminum hydraulic shoring is provided as a method of protection against cave-ins in trenches that do not exceed 20 feet (6.1m) in depth. This appendix must be used when design of the aluminum hydraulic protective system cannot be performed in accordance with 1926.652(c)(2).

SOIL CLASSIFICATION

In order to use data presented in this appendix, the soil type or types in which the excavation is made must first be determined using the soil classification method set forth in appendix A of subpart P of part 1926.

PRESENTATION OF INFORMATION

Information is presented in several forms as follows:

1. Information is presented in tabular form in Tables D-1.1, D-1.2, D-1.3 and D-1.4. Each table presents the maximum vertical and horizontal spacings that may be used with various aluminum member sizes and various hydraulic cylinder sizes. Each table contains data only for the particular soil type in which the excavation or portion of the excavation is made. Tables D-1.1 and D-1.2 are for vertical shores in Types A and B soil. Tables D-1.3 and D-1.4 are for horizontal waler systems in Types B and C soil.
2. Information concerning the basis of the tabular data and the limitations of the data is presented in paragraph (d) of this appendix.
3. Information explaining the use of the tabular data is presented in paragraph (e) of this appendix.
4. Information illustrating the use of the tabular data is presented in paragraph (f) of this appendix.
5. Miscellaneous notations (Footnotes) regarding Table D-1.1 through D-1.4 are presented in paragraph (g) of this appendix.
6. Figures, illustrating typical installations of hydraulic shoring, are included just prior to the Tables. The illustrations page is entitled "Aluminum Hydraulic Shoring: Typical Installations."

BASIS AND LIMITATIONS OF THE DATA

Rails and Wales

Vertical shore rails and horizontal wales are those that meet the Section Modulus requirements in the D-1 Tables. Aluminum material is 6061-T6 or material of equivalent strength and properties.

Hydraulic Cylinders Specifications

1. Two-inch cylinders shall be a minimum 2-inch inside diameter with a minimum safe working capacity of no less than 18,000 pounds axial compressive load at maximum extension. Maximum extension is to include full range of cylinder extensions as recommended by product manufacturer.
2. Three-inch cylinders shall be a minimum 3-inch inside diameter with a safe working capacity of not less than 30,000 pounds axial compressive load at extensions as recommended by product manufacturer.

Limitation of Application

It is not intended that the aluminum hydraulic specification apply to every situation that may be experienced in the field. These data were developed to apply to the situations that are most commonly experienced in current trenching practice. Shoring systems for use in situations that are not covered by the data in this appendix must be otherwise designed as specified in this part.

When any of the following conditions are present, the members specified in the Tables are not considered adequate. In this case, an alternative aluminum hydraulic shoring system or other type of protective system must be designed in accordance with 1926.652.

1. When vertical loads imposed on cross braces exceed a 100 Pound gravity load distributed on a one foot section of the center of the hydraulic cylinder.
2. When surcharge loads are present from equipment weighing in excess of 20,000 pounds.
3. When only the lower portion of a trench is shored and the remaining portion of the trench is sloped or benched unless: The sloped portion is sloped at an angle less steep than three horizontal to one vertical; or the members are selected from the tables for use at a depth which is determined from the top of the overall trench, and not from the toe of the sloped portion.

USE OF TABLES

D-1.1, D-1.2, D-1.3 and D-1.4. The members of the shoring system that are to be selected using this information are the hydraulic cylinders, and either the vertical shores or the horizontal wales. When a waler system is used the vertical timber sheeting to be used is also selected from these tables. The Tables D-1.1 and D-1.2 for vertical shores are used in Type A and B soils that do not require sheeting. Type B soils that may require sheeting, and Type C soils that always require sheeting, are found in the horizontal wale Tables D-1.3 and D-1.4. The soil type must first be determined in accordance with the soil classification system described in appendix A to subpart P of part 1926. Using the appropriate table, the selection of the size and spacing of the members is made. The selection is based on the depth and width of the trench where the members are to be installed. In these tables the vertical spacing is held constant at four feet on center. The tables show the maximum horizontal spacing of cylinders allowed for each size of wale in the waler system tables, and in the vertical shore tables, the hydraulic cylinder horizontal spacing is the same as the vertical shore spacing.

EXAMPLE TO ILLUSTRATE THE USE OF THE TABLES

Example 1

A trench dug in Type A soil is 6 feet deep and 3 feet wide. From Table D-1.1: Find vertical shores and 2-inch diameter cylinders spaced 8 feet on center (o.c.) horizontally and 4 feet on center (o.c.) vertically. (See Figures 1 & 3 for typical installations.)

Example 2

A trench is dug in Type B soil that does not require sheeting, 13 feet deep and 5 feet wide. From Table D-1.2: Find vertical shores and 2 inch diameter cylinders spaced 6.5 feet o.c. horizontally and 4 feet o.c. vertically. (See Figures 1 & 3 for typical installations.)

Example 3

A trench is dug in Type B soil that does not require sheeting, but does experience some minor raveling of the trench face. the trench is 16 feet deep and 9 feet wide. From Table D-1.2: Find vertical shores and 2 inch diameter cylinder (with special oversleeves as designated by Footnote #2) spaced 5.5 feet o.c. horizontally and 4 feet o.c. vertically. Plywood (per Footnote (g)(7) to the D-1 Table) should be used behind the shores. (See Figures 2 & 3 for typical installations.)

Example 4

A trench is dug in previously disturbed Type B soil, with characteristics of a Type C soil, and will require sheeting. The trench is 18 feet deep, and 12 feet wide 8 foot horizontal spacing between cylinders is desired for working space. From Table D-1.3: Find horizontal wale with a section modulus of 14.0 spaced at 4 feet o.c. vertically and 3 inch diameter cylinder spaced at 9 feet maximum o.c. horizontally, 3 x 12 timber sheeting is required at close spacing vertically. (See Figure 4 for typical installation.)

Example 5

A trench is dug in Type C soil, 9 feet deep and 4 feet wide. Horizontal cylinder spacing in excess of 6 feet is desired for working space. From Table D-1.4: Find horizontal wale with a section modulus of 7.0 and 2-inch diameter cylinders spaced at 6.5 feet o.c. horizontally. Or, find horizontal wale with a 14.0 section modulus and 3-inch diameter cylinder spaced at 10 feet o.c. horizontally. Both wales are spaced 4 feet o.c. vertically, 3 x 12 timber sheeting is required at close spacing vertically. (See Figure 4 for typical installation.)

FOOTNOTES AND GENERAL NOTES FOR TABLES D-1.1, D-1.2, D-1.3, AND D-1.4

1. For applications other than those listed in the tables, refer to 1926.652(c)(2) for use of manufacturer's tabulated data. For trench depths in excess of 20 feet, refer to *Designs Using Manufacture's Tabulated Data* and *Designs Using Other Tabulated Data*.
2. 2-inch diameter cylinders, at this width, shall have structural steel tube (3.5 x 3.5 x 0.1875) oversleeves, or structural oversleeves of manufacturer's specification, extending the full, collapsed length.
3. Hydraulic cylinders capacities.

- Two-inch cylinders shall be a minimum 2-inch inside diameter with a safe working capacity of not less than 18,000 pounds axial compressive load at maximum extension. Maximum extension is to include full range of cylinder extensions as recommended by product manufacturer.
 - Three-inch cylinders shall be a minimum 3-inch inside diameter with a safe work capacity of not less than 30,000 pounds axial compressive load at maximum extension. Maximum extension is to include full range of cylinder extensions as recommended by product manufacturer.
4. All spacing indicated is measured center to center.
 5. Vertical shoring rails shall have a minimum section modulus of 0.40 inch.
 6. When vertical shores are used, there must be a minimum of three shores spaced equally, horizontally, in a group.
 7. Plywood shall be 1.125-inch thick softwood or 0.75 inch thick, 14 ply, arctic white birch (Finland form). Please note that plywood is not intended as a structural member, but only for prevention of local raveling (sloughing of the trench face) between shores.
 8. See appendix C for timber specifications.
 9. Wales are calculated for simple span conditions.
 10. See appendix D, item (d), for basis and limitations of the data.

ALUMINUM HYDRAULIC SHORING TYPICAL INSTALLATIONS

Figure 20: Vertical Aluminum Hydraulic Shoring (Spot Bracing)

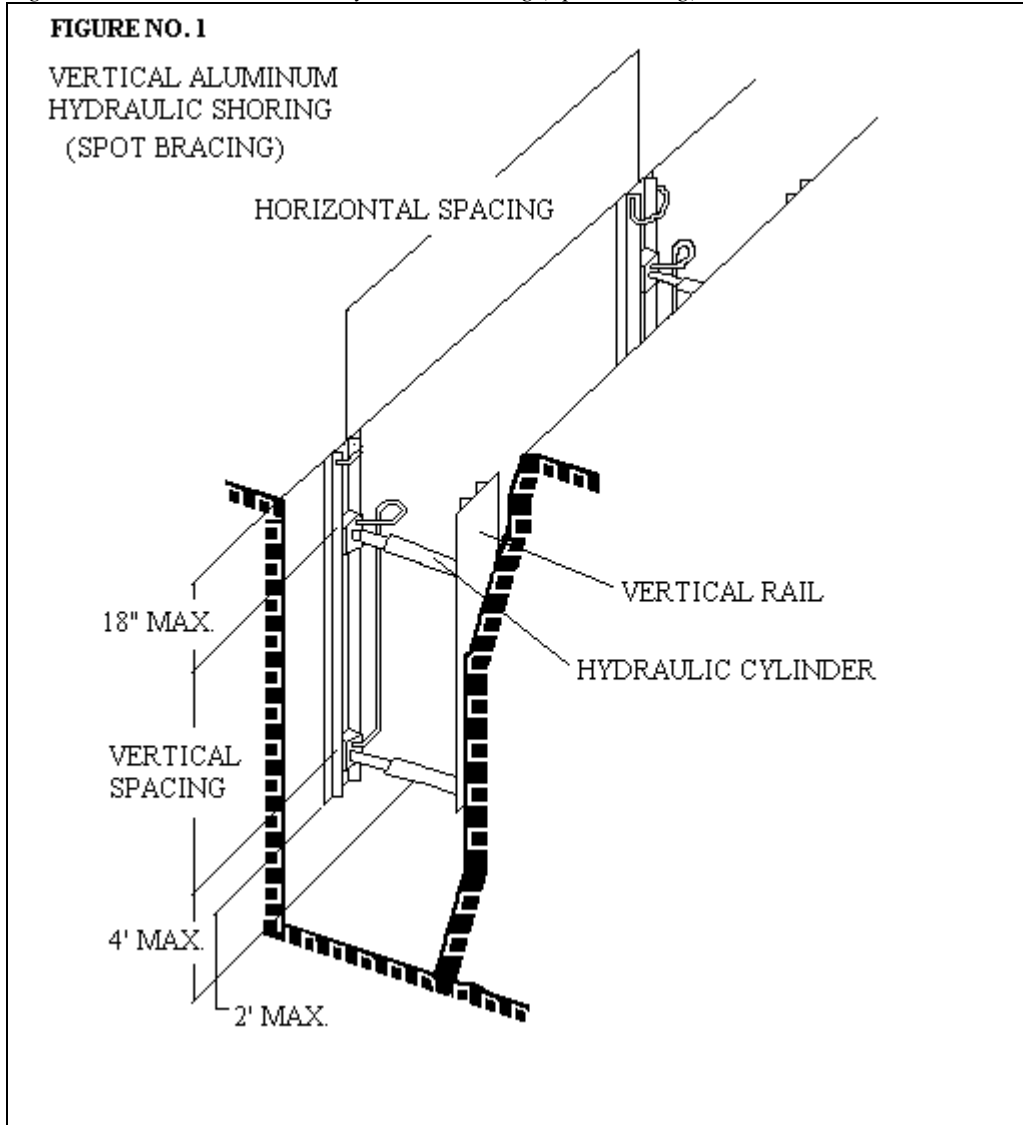

Figure 21: Vertical Aluminum Hydraulic Shoring (with Plywood)

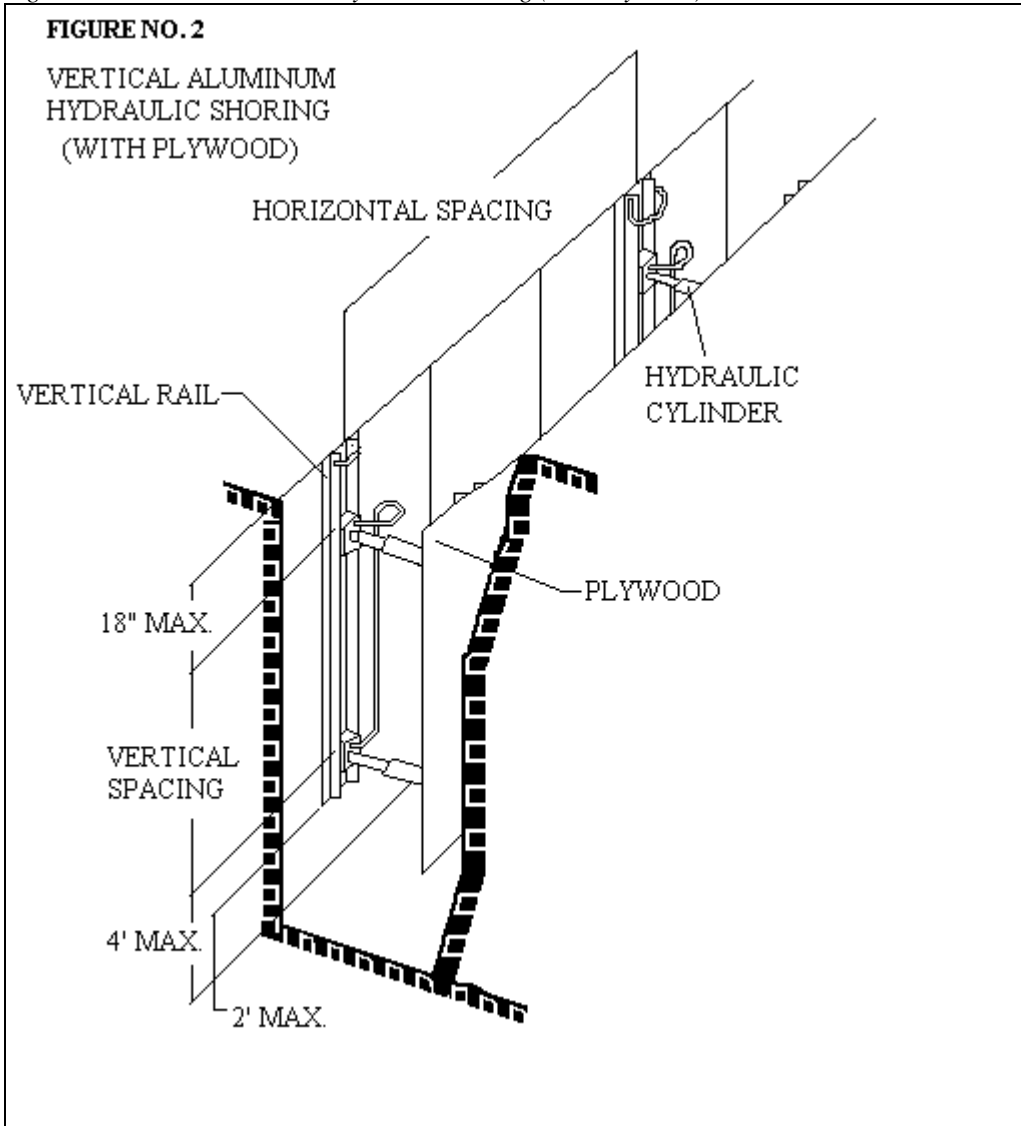

Figure 22: Vertical Aluminum Hydraulic Shoring (Stacked)

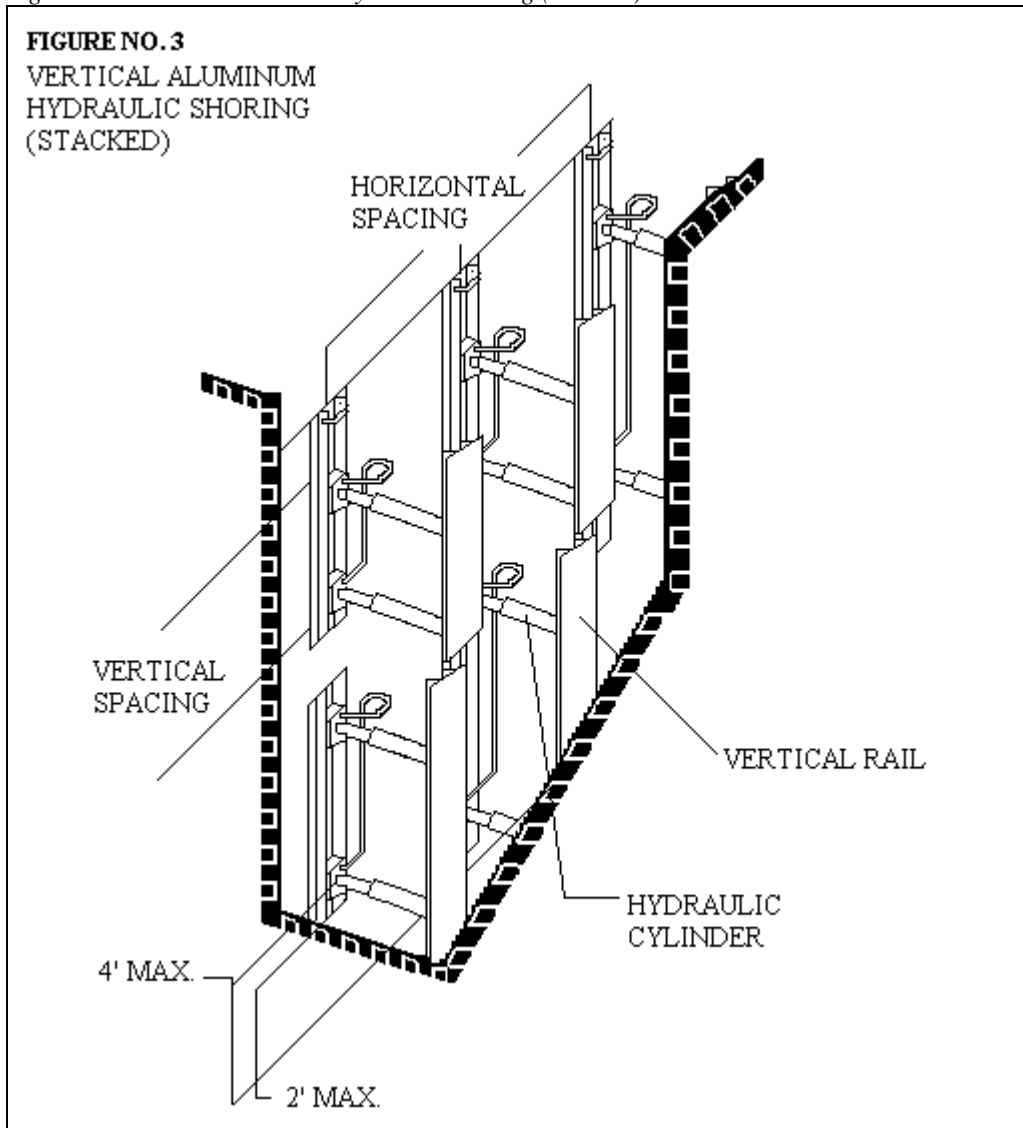

Figure 23: Aluminum Hydraulic Shoring - Waler System (Typical)

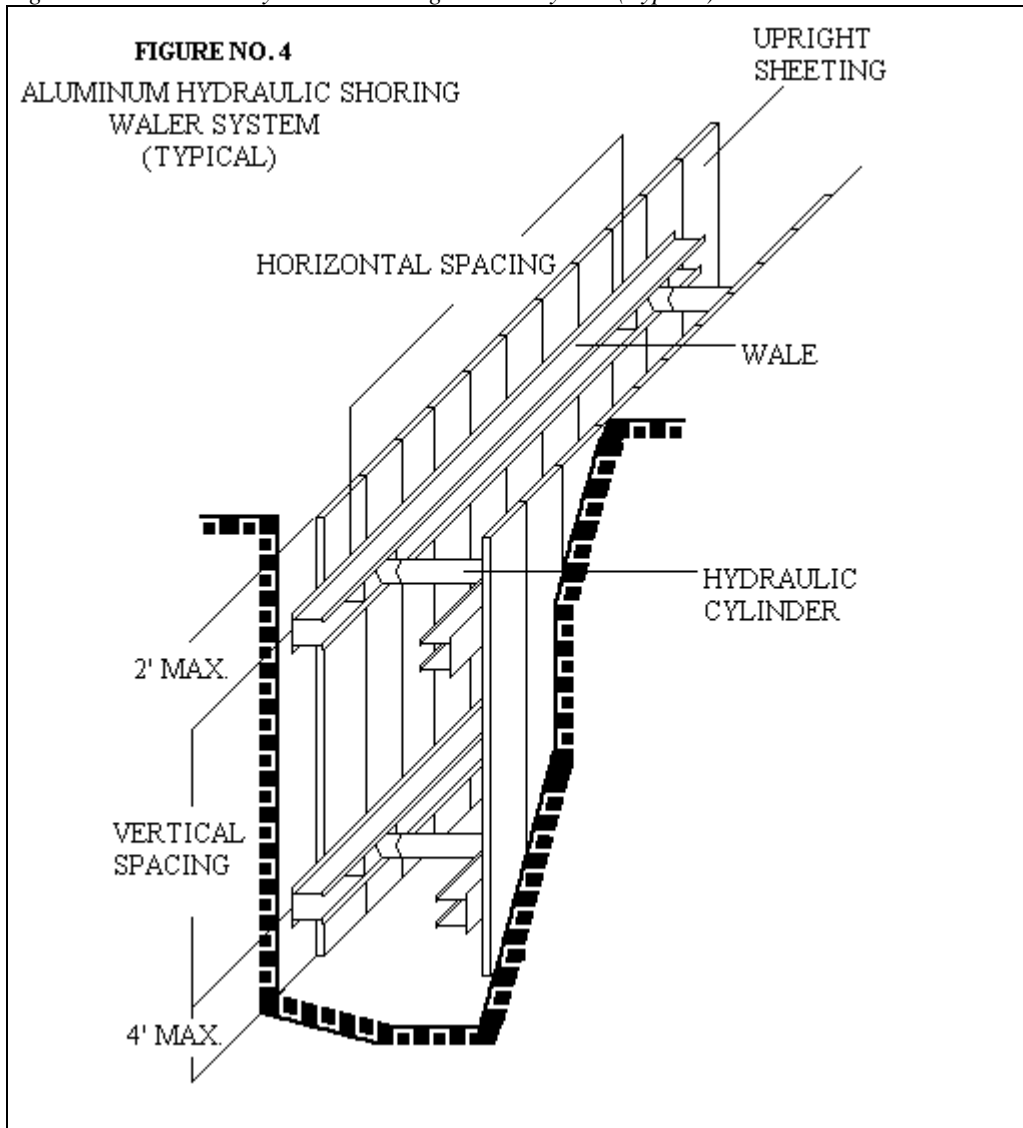

TABLE D - 1.1

Aluminum Hydraulic Shoring Vertical Shores for Soil Type A					
Depth of Trench (Feet)	Hydraulic Cylinders				
	Max. Horz. Spacing (Feet)	Max. Vert. Spacing (Feet)	Width of Trench (Feet)		
			Up to 8	Over 8 Up to 12	Over 12 Up to 15
Over 5 Up to 10	8	4	2 Inch Diameter	2 Inch Diameter (Note 2)	3 Inch Diameter
Over 10 Up to 15	8	4	2 Inch Diameter	2 Inch Diameter (Note 2)	3 Inch Diameter
Over 15 Up to 20	7	4	2 Inch Diameter	2 Inch Diameter (Note 2)	3 Inch Diameter
Over 20	See Note 1				

* Footnotes and general notes for Tables D-1.1, D-1.2, D-1.3, and D-1.4

Table 11: D-1.1

TABLE D - 1.2

Aluminum Hydraulic Shoring Vertical Shores for Soil Type B					
Depth of Trench (Feet)	Hydraulic Cylinders				
	Max. Horz. Spacing (Feet)	Max. Vert. Spacing (Feet)	Width of Trench (Feet)		
			Up to 8	Over 8 Up to 12	Over 12 Up to 15
Over 5 Up to 10	8	4	2 Inch Diameter	2 Inch Diameter (Note 2)	3 Inch Diameter
Over 10 Up to 15	6.5	4	2 Inch Diameter	2 Inch Diameter (Note 2)	3 Inch Diameter
Over 15 Up to 20	5.5	4	2 Inch Diameter	2 Inch Diameter (Note 2)	3 Inch Diameter
Over 20	See Note 1				

* Footnotes and general notes for Tables D-1.1, D-1.2, D-1.3, and D-1.4

Table 12: D-1.2

TABLE D - 1.3

Aluminum Hydraulic Shoring Waler Systems for Soil Type B						
Depth of Trench (Feet)	Wales**		Hydraulic Cylinders			
	Vert. Spacing (Feet)	Section Modulus [In (3)]	Width of Trench (Feet)			
			Up to 8		Over 8 Up to 12	
			Horz. Spacing	Cylinder Diameter	Horz. Spacing	Cylinder Diameter
Over 5 Up to 10	4	3.5	8.0	2 In	8.0	2 In (Note 2)
	4	7.0	9.0	2 In	9.0	2 In (Note 2)
Over 10 Up to 15	4	14.0	12.0	3 In	12.0	3 In
	4	3.5	6.0	2 In	6.0	2 In (Note 2)
	4	7.0	8.0	3 In	8.0	3 In
Over 15 Up to 20	4	14.0	10.0	3 In	10.0	3 In
	4	3.5	5.5	2 In	5.5	2 In (Note 2)
Over 20	4	7.0	6.0	3 In	6.0	3 In
	4	14.0	9.0	3 In	9.0	3 In
Over 20	See Note 1					

* Footnotes and general notes for Tables D-1.1, D-1.2, D-1.3, and D-1.4

** Consult product manufacturer and/or qualified engineer for Section Modulus of available wales.

Aluminum Hydraulic Shoring Waler Systems for Soil Type B							
Depth of Trench (Feet)	Wales**		Hydraulic Cylinders		Timber Uprights		
	Vert. Spacing (Feet)	Section Modulus [In (3)]	Width of Trench (Feet) Over 12 Up to 15		Max. Horz. Spacing (on Center)		
			Horz. Spacing	Cylinder Diameter	Solid Sheet	2 Feet	3 Feet
Over 5 Up to 10	4	3.5	8.0	3 In			3 x 12
	4	7.0	9.0	3 In			3 x 12
	4	14.0	12.0	3 In			3 x 12
Over 10 Up to 15	4	3.5	6.0	3 In		3 x 12	
	4	7.0	8.0	3 In		3 x 12	
	4	14.0	10.0	3 In		3 x 12	
Over 15 Up to 20	4	3.5	5.5	3 In	3 x 12		
	4	7.0	6.0	3 In	3 x 12		
	4	14.0	9.0	3 In	3 x 12		
Over 20	See Note 1						

* Footnotes and general notes for Tables D-1.1, D-1.2, D-1.3, and D-1.4

** Consult product manufacturer and/or qualified engineer for Section Modulus of available wales.

Table 13: D-1.3

TABLE D - 1.4

Aluminum Hydraulic Shoring Waler Systems for Soil Type C						
Depth of Trench (Feet)	Wales**		Hydraulic Cylinders			
	Vert. Spacing (Feet)	Section Modulus [In (3)]	Width of Trench (Feet)			
			Up to 8		Over 8 Up to 12	
			Horz. Spacing	Cylinder Diameter	Horz. Spacing	Cylinder Diameter
Over 5 Up to 10	4	3.5	6.0	2 In	6.0	2 In (Note 2)
	4	7.0	6.5	2 In	6.5	2 In (Note 2)
Over 10 Up to 15	4	14.0	10.0	3 In	10.0	3 In
	4	3.5	4.0	2 In	4.0	2 In (Note 2)
	4	7.0	5.5	3 In	5.5	3 In
Over 15 Up to 20	4	14.0	8.0	3 In	8.0	3 In
	4	3.5	3.5	2 In	3.5	2 In (Note 2)
Over 20	4	7.0	5.0	3 In	5.0	3 In
	4	14.0	6.0	3 In	6.0	3 In
Over 20	See Note 1					

* Footnotes and general notes for Tables D-1.1, D-1.2, D-1.3, and D-1.4

** Consult product manufacturer and/or qualified engineer for Section Modulus of available wales.

Aluminum Hydraulic Shoring Waler Systems for Soil Type C						
Depth of Trench (Feet)	Wales**		Hydraulic Cylinders		Timber Uprights	
	Vert. Spacing (Feet)	Section Modulus [In (3)]	Width of Trench (Feet) Over 12 Up to 15		Max. Horz. Spacing (on Center)	
			Horz. Spacing	Cylinder Diameter	Solid Sheet	2 Feet
Over 5 Up to 10	4	3.5	6.0	3 In	3 x 12	
	4	7.0	6.5	3 In	3 x 12	
	4	14.0	10.0	3 In	3 x 12	
Over 10 Up to 15	4	3.5	4.0	3 In	3 x 12	
	4	7.0	5.5	3 In	3 x 12	
	4	14.0	8.0	3 In	3 x 12	
Over 15 Up to 20	4	3.5	3.5	3 In	3 x 12	
	4	7.0	5.0	3 In	3 x 12	
	4	14.0	6.0	3 In	3 x 12	
Over 20	See Note 1					

* Footnotes and general notes for Tables D-1.1, D-1.2, D-1.3, and D-1.4

** Consult product manufacturer and/or qualified engineer for Section Modulus of available wales.

Table 14: D-1.4

ALTERNATIVES TO TIMBER SHORING

Figure 24: Aluminum Hydraulic Shoring

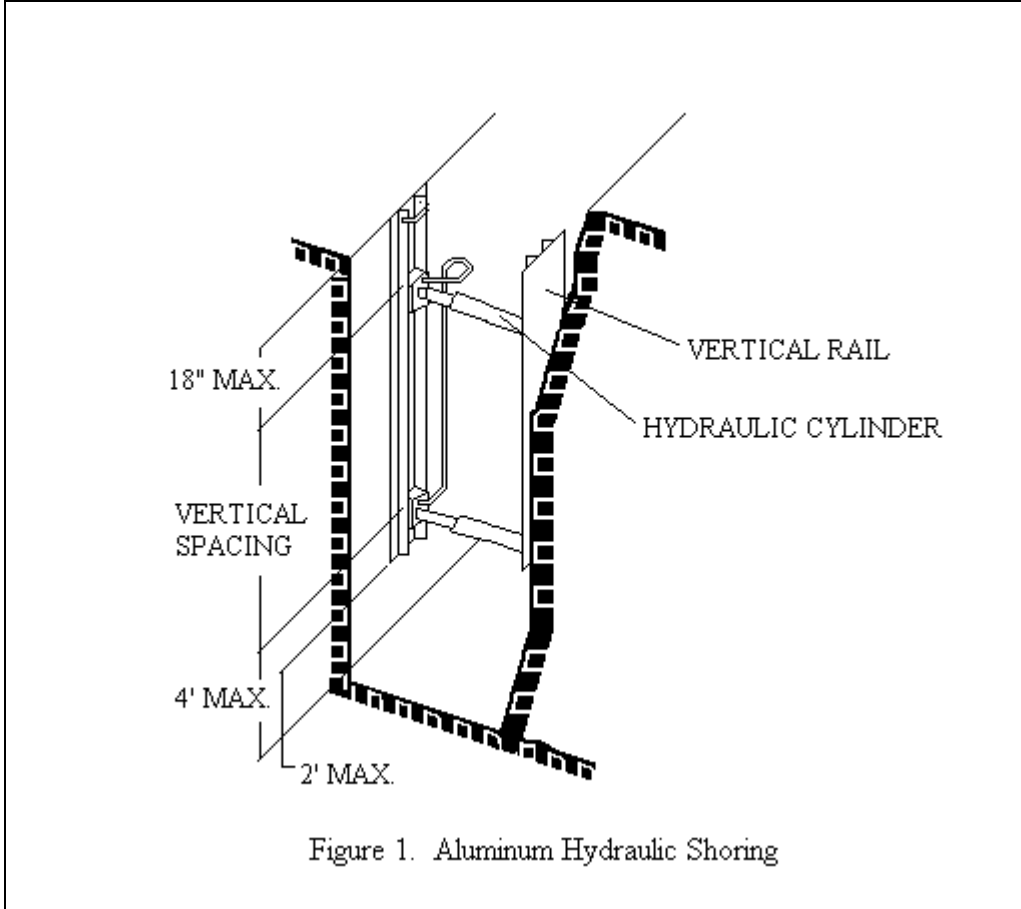

Figure 25: Pneumatic/Hydraulic Shoring

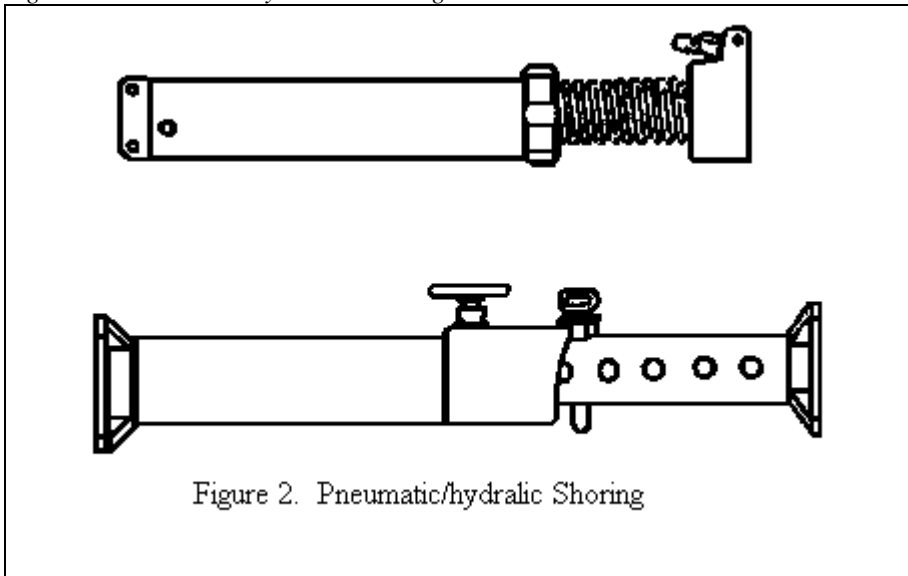

Figure 26: Trench Jacks and Trench Shields

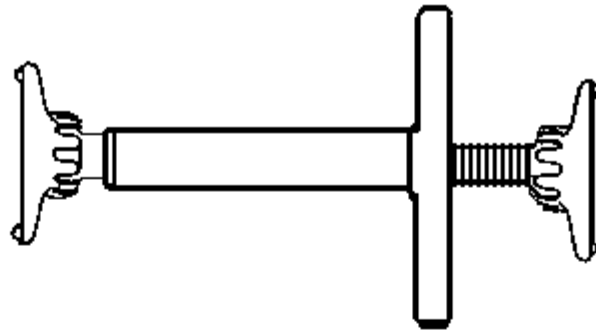

Figure 3. Trench Jacks (Screw Jacks)

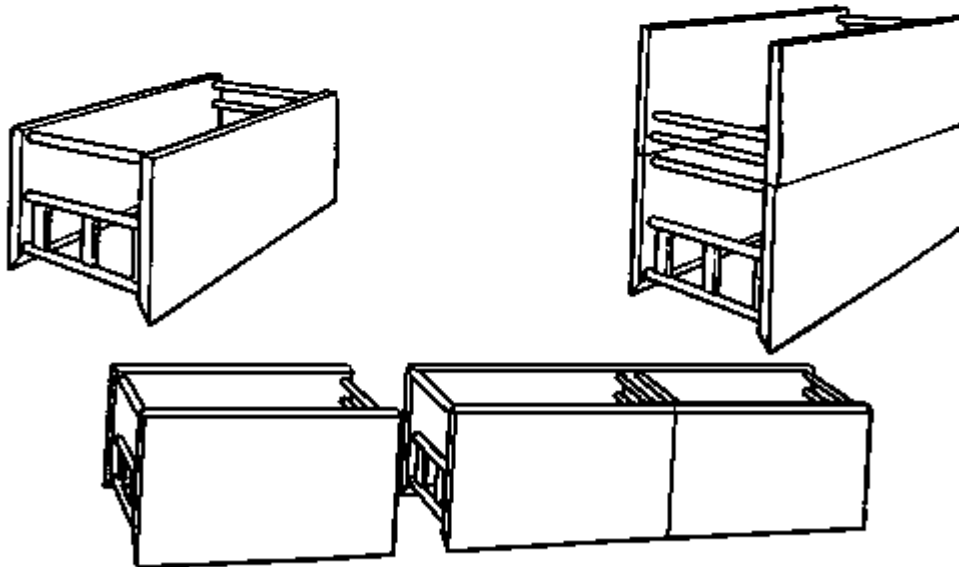

Figure 4. Trench Shields

Part 8 Appendix E:

Selection of Protective Systems

DIAGRAMS

The following figures are a graphic summary of the requirements contained in this section for excavations 20 feet or less in depth. Protective systems for use in excavations more than 20 feet in depth must be designed by a registered professional engineer in accordance with 1926.652(b) and (c).

Figure 27: Preliminary Decisions

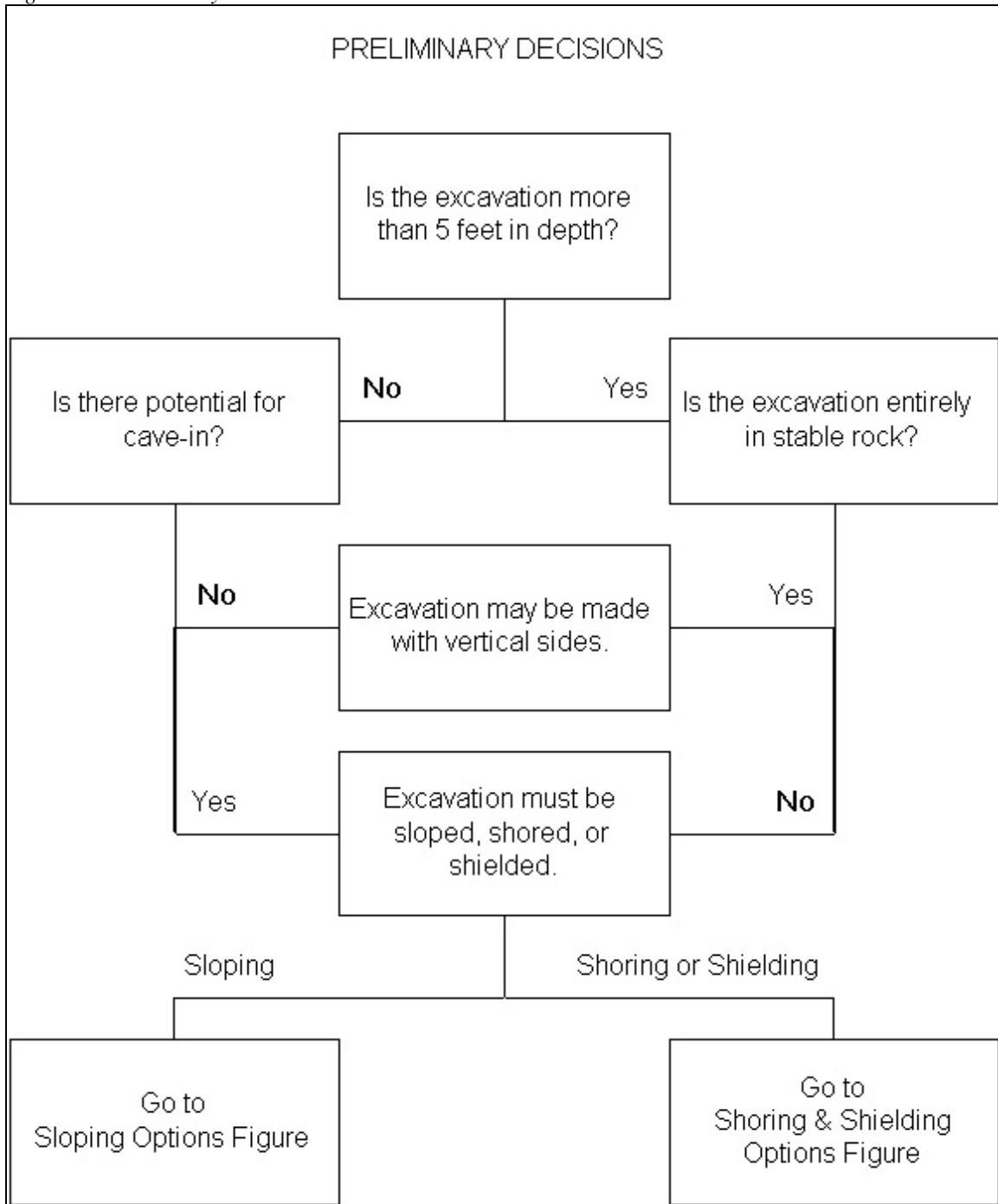

Figure 28: Sloping Option

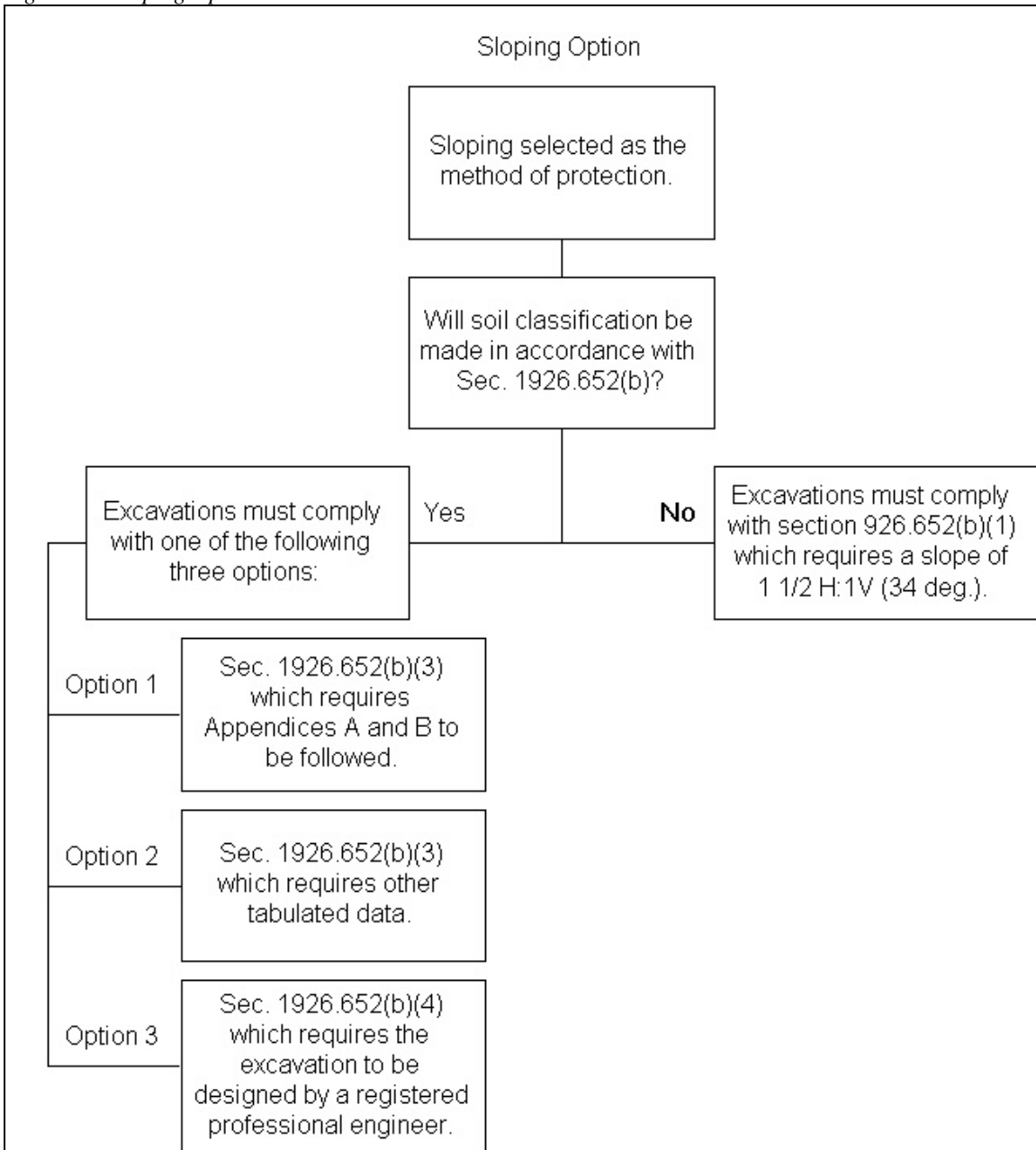
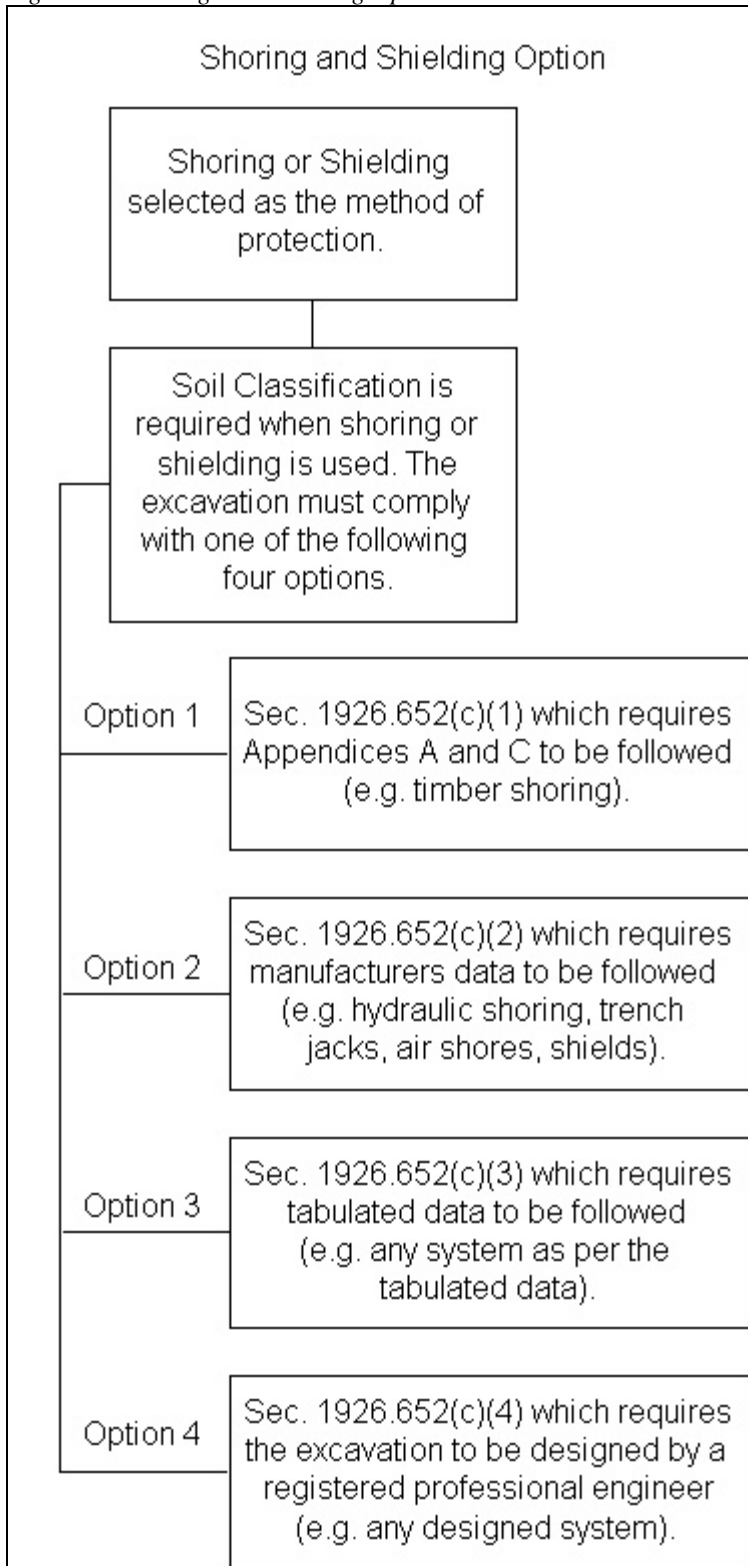

Figure 29: Shoring and Shielding Option



Part 8 Checklist: Sample Pre-Excavation

Sample Pre-Excavation Checklist

Project Name: _____

Name of Project Competent Person: _____

Employee Training and Pre-Excavation Briefing:

Does this job require special training? YES _____ NO _____
Safe excavation and rescue training conducted on: Date: _____
Mandatory pre-excavation briefing conducted on: Date: _____

Soil Classification:

Will the competent person classify the soil based on it's properties and site conditions?
YES _____ NO _____

If yes, continue. If no, then soil is assumed to be Type "C".

Based on a visual observation, which best describes the soil in this excavation?

Type "A" _____ Type "B" _____ Type "C" _____

Based on a visual observation, which best describes the moisture condition of the soil?

Dry Soil _____ Moist Soil _____ Wet Soil _____ Saturated Soil _____

Based on at least one manual test , what classification is the soil in this excavation?

Stable Rock _____ Type "A" _____ Type "B" _____ Type "C" _____

What manual test was used to determine the soil type?

Plasticity _____ Dry Strength _____ Thumb Penetration _____ Other (list) _____

Underground Installations: (Existing Utilities / Obstructions)

Have the estimated locations of all underground installations been determined prior to excavation?

YES _____ NO _____ N/A _____

Have Utility companies been contacted and advised of proposed work?

YES _____ NO _____ N/A _____

If underground installations are exposed, will they be protected, supported, or removed while excavation is open?

YES _____ NO _____ N/A _____

Access and Egress:

Are stairways, ramps, or ladders positioned every 25 ft? YES _____ NO _____ N/A _____

Exposure to Vehicular Traffic:

Are personnel who are exposed to either public or project traffic wearing reflective or high-visibility vests?

YES _____ NO _____ N/A _____

Exposure to Falling Loads:

Are employees prohibited from standing underneath loads handled by lifting or digging equipment?

YES _____ NO _____ N/A _____

Protection of Employees from Loose Rock , Soil, or Equipment :

Are employees protected from falling rock, soil, or equipment by placing these materials a minimum of 2 ft. from the edge of the excavation or behind a retaining device?

YES _____ NO _____ N/A _____

Fall Protection:

Are standard guardrails provided on walkways and bridges that cross over 6 ft. and wider excavations?

YES _____ NO _____ N/A _____

Are all excavations that are accessible to the public adequately barricaded or covered when unattended?

YES _____ NO _____ N/A _____

Inspections:

Are daily inspections of excavations being performed by the competent person?

YES _____ NO _____ N/A _____

Are inspections being performed by a competent person after every rainstorm or other hazard-increasing occurrence?

YES _____ NO _____ N/A _____

Are employees removed from the excavation if the competent person finds evidence of a situation that could result in a possible cave-in, protective system failure, hazardous atmosphere, or other hazardous conditions?

YES _____ NO _____ N/A _____

Shielding or Shoring:

Have all shielding, shoring, or other protective systems been designed by a registered professional engineer and accompanied by tabulated data from the manufacturer?

YES _____ NO _____ N/A _____

Are shielding, shoring, and other protective systems checked each day to detect movement and possible failure?

YES _____ NO _____ N/A _____

I have inspected the excavation described in this checklist:

Worksheet Completed By:

(Signature of Competent Person) (Date)

Part 8 Checklist: Trench & Excavation

TRENCH & EXCAVATION CHECKLIST

General Conditions and Inspection

1. Do you have an official "Competent Person" (a trained leader who oversees safety practices) who has specific training in soil analysis, use of protective systems, and the requirements of the Excavations and Trenches Safety Orders?
2. Does the "Competent Person" have the authority to remove workers from the excavation immediately?
3. Are excavations, adjacent areas, and protective systems inspected and conditions documented by a Competent Person: Daily prior to the start of work, throughout the shift, and after any occurrence that could increase the hazard?
4. Are employees protected from loose rock or soil that could pose a hazard by falling or rolling into the excavation?
5. Do all workers wear hardhats?
6. Are extra materials and equipment set back at least 2 feet from the edge of the excavation?
7. Are barriers provided to mark and protect all open excavations, wells, pits, and shafts?
8. Are walkways and bridges over excavations 6 feet or more high and 30 inches wide equipped with standard guardrails and toe boards?
9. Are warning vests or other highly visible clothing provided and worn by employees exposed to vehicular traffic?
10. Are employees required to stand away from vehicles being loaded or unloaded?
11. Are warning systems established and used when equipment is operating near the edge of an excavation?
12. Are employees prohibited from being under suspended loads?
13. Are employees prohibited from working on the faces of sloped or benched excavations above other employees?

Underground Utilities

1. Are utilities companies contacted and/or utilities located before digging as required by local, state, and federal law?
2. Are the exact locations clearly marked?
3. Are underground installations protected, supported, or removed when an excavation is open?

Entering and Exiting

1. Are ladders or other means of access and exit in place in all trenches 4 feet or more deep?
2. Are all workers within 25 feet of a means of access and exit?
3. Are the ladders that are used in excavations secured and extended 3 feet above edge of the excavation? (stepladders are not to be used)
4. Are ramps used by employees designed to have a 5:1 / 20% slope maximum?"
5. Are ramps, planks or walkways constructed of materials of uniform thickness, fastened together, equipped with no-slip surfaces?
6. Are employees protected from cave-ins when entering or exiting excavation?

Weather and Wet Conditions

1. Are precautions taken to protect employees from water accumulation?
2. Is water removal equipment monitored by "Competent Person?"
3. Is surface water or runoff diverted after rainstorms?

Protective Systems

1. Are protective systems chosen based upon soils analysis, trench depth and expected loads?
2. For excavations exceeding 20 feet in depth, has a Registered Professional Engineer designed the protective system?
3. Are materials and equipment that are used for protective systems inspected and in good condition?
4. Are damaged materials and equipment immediately removed from service?
5. Are damaged materials and equipment inspected by a Registered Professional Engineer after repairs are made and before being placed back in service?
6. Are protective systems installed without exposing employees to hazards of cave-ins, collapses, or threat of being struck by materials or equipment?
7. Are support systems provided to insure stability of adjacent structures, buildings, roadways, sidewalks, etc.?
8. Are excavations dug below the level of a base or footing supported, and have they been approved by a Registered Professional Engineer?
9. Does back-filling progress with the removal of the support system?
10. Is a shield system installed to prevent lateral movement?
11. Are employees prohibited from remaining in a shield system during vertical movement?

Air Monitoring and Hazardous Atmospheres

1. Do you test the atmosphere within excavations for oxygen levels, or combustible or toxic contaminants?
2. Is emergency rescue equipment available when hazardous atmospheres could or do exist?
3. Are employees trained to use personal protective equipment and other rescue equipment?

Part 9: Fall Protection

INTRODUCTION

On School Construction Authority Projects where Fall Protection is used, the Federal OSHA Standards, current New York City Department of Building Codes and School Construction Authority Safety Program & Procedures Manual and any other governing agencies laws, regulations, procedures shall be adhered to. The most stringent of these standards shall be applicable.

The employer shall determine if the walking/working surfaces on which its employees are to work have the strength and structural integrity to support employees' safety. Employees shall be allowed to work on those surfaces only when the surfaces have the requisite strength and structural integrity.

BASIC TERMINOLOGY

Definitions for the following terms are listed alphabetically within the Glossary located at the back of this publication:

- Anchorage
- Body belt
- Body Harness
- Buckle
- Connector
- Dangerous Equipment
- Deceleration Device
- Equivalent
- Failure
- Free Fall
- Free Fall Distance
- Guardrail System
- Hole
- Infeasible
- Lanyard
- Leading
- Lifeline
- Low-sloped Roof
- Lower Level
- Mechanical Equipment
- Opening
- Overhand Bricklaying and Related Work
- Personal Fall Arrest System
- Positioning Device
- Rope Grab
- Roof
- Roofing Work
- Safety Monitoring System
- Self Retracting Lanyard
- Snaphook
- Steep Roof
- Toeboard
- Unprotected Sides & Edges
- Walking Surface
- Work Area



SCA GENERAL REQUIREMENTS

1. Fall Protection shall be strictly enforced throughout School Construction Authority Projects.
2. Each employee on a walking/working surface (horizontal and vertical surface) with an unprotected side or edge which is six feet (6') or more above a lower level shall be protected from falling by a guardrail systems, safety net systems, warning line system, secured covers or personal fall arrest systems.
3. Slipping hazards. Employers shall not suffer or permit any employee to use a floor, passageway, walkway, scaffold, platform or other elevated working surface which is in a slippery condition. Ice, snow, water, grease and any other foreign substance which may cause slippery footing shall be removed, sanded or covered to provide safe footing.
4. Exterior tarps, netting systems, or covers are not to be secured or attached to the top rail of the guardrail system. However, attachment to the midrail will be permitted based on a design provided by a Licensed P.E.

FALL PROTECTION SYSTEMS

Unprotected Sides and Edges

Each employee on a walking/working surface (horizontal and vertical surface) with an unprotected side or edge which is six feet (6') or more above a lower level shall be protected from falling by a guardrail systems, safety net systems, or personal fall arrest systems.

Leading Edges

Each employee who is constructing a leading edge six feet or more above a lower level shall be protected from falling with guardrail systems, safety net systems or personal fall arrest systems.



Note: There is a presumption that it is feasible and will not create a greater hazard to implement a fall protection system. Accordingly, the employer has the burden of establishing that it is appropriate to implement a fall protection plan for a particular workplace situation, in lieu of implementing any of those systems.



Exception: When the employer can demonstrate that it is infeasible or creates a greater hazard to use a recognized fall protection system, the employer shall develop and implement a fall protection plan which meets the requirements of Fall Protection.

Each employee on a walking/working surface six feet or more above a lower level where leading edges are under construction, but who is not engaged in the leading edge work, shall be protected from falling by a guardrail system, safety net system, or personal fall arrest system. If a guardrail system is chosen to provide the fall protection, and a controlled access zone has already been established for leading edge work, the control line may be used in lieu of a guardrail along the edge that parallels the leading edge.

Hoist Areas

Each employee in a hoist area shall be protected from falling six feet or more to a lower level by guardrail systems or personal fall arrest systems

If guardrail systems (chain, gate, or guardrail) or portions thereof are removed to facilitate the hoisting operation (like during materials landing) and an employee must lean through the access opening or out over the edge of the access opening (to receive or guide equipment and materials; for example); that employee shall be protected from fall hazards by a personal fall arrest system.

Holes

Each employee on a walking/working surfaces shall be protected from falling through holes (including skylights) more than six feet above lower levels, by personal fall arrest systems, covers, or guardrail systems erected around such holes.

Each employee on a walking/working surface shall be protected from tripping in or stepping into or through holes (including skylights) by covers.

Each employee on a walking/working surface shall be protected from objects falling through holes (including skylights) by covers.

Formwork and Reinforcing Steel

Each employee on the face of formwork or reinforcing steel shall be protected from falling six feet or more to a lower level by personal fall arrest systems, safety net systems or positioning device systems.

Ramps, Runways and Other Walkways

Each employee on ramps, runways and other walkways shall be protected from falling six feet or more to lower levels by guardrail system.

Excavations

Each employee at the edge of an excavation six feet or more in depth shall be protected from falling by guardrail systems, fences, or barricades when the excavations are not readily seen because of plant growth or other visual barrier.

Each employee at the edge of a well, pit, shaft and similar excavation six feet or more in depth shall be protected from falling by guardrail systems, fences, barricades or covers.

Dangerous Equipment

Each employee less than six feet above dangerous equipment shall be protected from falling into or onto the dangerous equipment by guardrail systems or by equipment guards.

Each employee six feet or more above dangerous equipment shall be protected from fall hazards by guardrail systems, personal fall arrest systems, or safety net systems.

Overhand Bricklaying and Related Work

Except as otherwise provided in the next paragraph on this section, each employee performing overhand bricklaying and related work six feet or more above lower levels, shall be protected from falling by guardrail systems, safety net systems, personal fall arrest systems or shall work in a controlled access zone.

Each employee reaching more than 10 inches below the level of the walking/working surface on which they are working, shall be protected from falling by a guardrail system, safety net system, or personal fall arrest system.

Roofing Work On low Slope Roofs

Except as otherwise provided in the following guidelines under this section of roofing, each employee engaged in roofing activities on low slope roofs, with unprotected side and edges six feet or more above lower levels shall be protected from falling by guardrail systems, safety net systems, personal fall arrest systems or a combination of warning line systems and guardrail systems, warning line system and safety net system or warning line system and personal fall arrest system, or warning line system.

Steep Roofs

Each employee on a steep roof with unprotected sides and edges six feet or more above lower levels shall be protected from falling by a guardrail system with toeboards, safety net systems, or personal fall arrest systems.

Pre-Cast Concrete Erection

Each employee engaged in the erection of pre-cast concrete members (including, but not limited to the erection of wall panels, columns, beams, and floor and roof “tee”.) and related operations such as grouting of pre-cast concrete members, who is six feet or more above a lower level shall be protected from falling by guardrail systems, safety net systems or personal fall arrest systems, unless another provision of this section provides for an alternative fall protection measure.



Exception: When the employer can demonstrate that it is infeasible or creates a greater hazard to use these systems, the employer shall develop and implement a fall protection plan.



Note: There is a presumption that it is feasible and will not create a greater hazard to implement at least one of the above listed fall protection systems. Accordingly, the employer has the burden of establishing that it is appropriate to implement a fall protection plan for a particular workplace situation, in lieu of implementing any of those systems.

Wall Openings

Each employee working on, at, above, or near wall openings (including those with chutes attached) where the outside bottom edge of the wall opening is six feet or more above a lower level and the inside bottom edge of the wall opening is lower than 39 inches above the walking/working surface, shall be protected from falling by the use of a guardrail system, a safety net system, or a personal fall arrest system.

Walking/Working Surfaces Not Otherwise Addressed

Except as provided in previously mentioned areas of this section, each employee on a walking/working surface six feet or more above a lower level shall be protected from falling by a guardrail system, safety net system, or personal fall arrest system.

Protection from Falling Objects – Shaft Openings

When an employee is exposed to falling objects below shaft openings such as but not limited to elevator shafts, stair well or floor penetrations, the employer shall have each employee wear a hard hat and shall implement one of the following measures:

Every place where persons are required to work under, or pass near the lower section or bottom of a shaft that is or may be exposed to falling material or objects shall be provided with suitable overhead protection. A secure cover consisting of planks at least two inches thick full size, exterior grade plywood at least three-quarters inch thick or material of equivalent strength shall be installed so as to cover the entire cross-sectional area of the opening **(In accordance with this SCA Safety Manual)**. Such cover shall be located at a point in the shaft not more than two stories or 30 feet, whichever is less, starting from the lowest level.

1. In lieu of such platform, an approved life net installed in compliance with this Safety Manual may be provided.
2. Erect a canopy structure and keep potential fall objects far enough from the edge of the higher level so that those objects would not go over the edge if they were accidentally displaced. Such overhead protection shall consist of tightly laid sound planks at least two inches thick full size, tightly laid three-quarter inch exterior grade plywood or other material of equivalent strength. Such overhead protection shall be provided with a supporting structure capable of supporting a loading of 100 pounds per square foot
3. Barricade the area to which objects could fall, prohibit employees from entering the barricaded area, and keep objects that may fall far enough away from the edge of a higher level so that those objects would not go over the edge if they were accidentally displaced

FALL PROTECTION SYSTEMS CRITERIA AND PRACTICES

General

Fall protection systems required by this part shall comply with the applicable provisions of this section.

Employers shall provide and install all fall protection systems required by this subpart for an employee, and shall comply with all other pertinent requirements of this subpart before that employee begins the work that necessitates the fall protection.

Guardrail Systems

Guardrail systems and their use shall comply with the following provisions.

1. Top edge height of top rails, or equivalent guardrail system members, shall be 42 inches plus or minus three inches (3") above the walking/working level. When conditions warrant, the height of the top edge may exceed the 45-inch height, provided the guardrail system meets all other criteria.



Note: When employees are using stilts, the top edge height of the top rail, or equivalent member, shall be increased an amount equal to the height of the stilts.

2. Midrails, screens, mesh, intermediate vertical members, or equivalent intermediate structural members shall be installed between the top edge of the guardrail system and the walking/working surface when there is no wall or parapet wall at least 21 inches high.

3. Midrails, when used, shall be installed at a height midway between the top edge of the guardrail system and the walking/working level.
4. Screens and mesh, when used shall extend from the top rail to the walking/working level and along the entire opening between top rail supports. Intermediate members (such as balusters) when used between posts, shall be not more than 19 inches apart.
5. Other structural members (such as additional Midrails and architectural panels) shall be installed such that there are no openings in the guardrail system that are more than 19 inches wide.
6. Guardrail systems shall be capable of withstanding, without failure, a force of at least 200 pounds applied within 2 inches of the top edge, in any outward or downward direction, at any point along the top edge.
7. When the 200-pound test load specified is applied in a downward direction, the top edge of the guardrail shall not deflect to a height less than 39 inches above the walking/working level.
8. Midrails, screens, mesh, intermediate vertical members, solid panels, and equivalent structural members shall be capable of withstanding, without failure, a force of at least 150 pounds applied in any downward or outward direction at any point along the midrail or other member.
9. Guardrail systems shall be so surfaced as to prevent injury to an employee from punctures or lacerations, and to prevent snagging of clothing.
10. The ends of all top rails and midrails shall not overhang the terminal post, except where such overhang does not constitute a projection hazard.
11. Steel banding and plastic banding shall not be used as top rails or midrails.
12. Top rails and midrails shall be at least one-quarter inch nominal diameter or thickness to prevent cuts and lacerations. If wire rope is used for top rails, it shall be flagged at not more than 6-foot intervals with high visibility material and secured at its termination points with a minimum of three (3) wire rope clips.
13. When guardrail systems are used at hoisting areas, a chain, gate or removable guardrail section shall be placed across the access opening between guardrail sections when hoisting operations are not taking place.
14. When guardrail systems are used at holes, they shall be erected on all unprotected sides or edges of the hole.
15. When guardrail systems are used around holes used for the passage of materials, the hole shall have not more than two sides provided with removable guardrail sections to allow the passage of materials. When the hole is not in use, it shall be closed over with a cover, or a guardrail system shall be provided along all unprotected sides and edges.
16. When guardrail systems are used around holes, which are used as points of access (such as ladderways), they shall be provided with a gate, or be so offset that a person cannot walk directly into the hole.
17. Guardrail systems used on ramps and runways shall be erected along each unprotected side or edge.
18. Manila, plastic or synthetic rope being used for top rails or midrails shall be inspected as frequently as necessary to ensure that it continues to meet the strength requirements of Item #6 of this section.

Safety Net Systems

Safety Net Systems and their use shall comply with the following provisions:

1. Safety nets shall be installed as close as practicable under the walking/working surface on which employees are working, but in no case more than 30 feet below such level. When nets are used on bridges, the potential fall area from the walking/working surface to the net shall be unobstructed.
2. Safety nets shall extend outward from the outermost projection of the work surface as follows:



Note: Measure the Vertical Distance from the working level to the horizontal plane of the net and measure the horizontal distance from the outer edge of the net to the edge of the working surface.

Distance Requirements	
Vertical Distance	Minimum Required Horizontal Distance
Up to 5 feet	8 feet
5 feet to 10 feet	10 feet
More than 10 feet	13 feet

Table 15: Safety Net Distance Requirements

3. Safety nets shall be installed with sufficient clearance under them to prevent contact with the surface or structures below when subjected to an impact force equal to requirements outlined in this section.
4. Safety nets and their installations shall be capable of absorbing an impact force equal to that produced by the drop test specified in this section.
5. Except as provided in this section, safety nets and safety net installations shall be drop tested at the jobsite after initial installation and before being used as a fall protection system, whenever relocated, after major repair, and 6 month intervals if left in one place. The drop test shall consist of a 400 pound bag of sand 30 +/- inches in diameter dropped into the net from the highest walking/working surface at which employees are exposed to fall hazards, but not from less than 42 inches above that level.
6. When the employer can demonstrate that it is unreasonable to perform the drop test required by this part, the employer (or designated competent person) shall certify that the net and net installation complies with the provisions of this section by preparing a certification record prior to the net being used as a fall protection system.

The certification record must include an identification of the net and net installation for which the certification record is being prepared: the date that it was determined, that the identified net and net installation complied with this section and the signature of the person making the determination and certification. The most recent certification record for each net and net installation shall be available at the jobsite for inspection.

7. Defective nets shall not be use, Safety nets shall be inspected at least once a week for wear, damage, and other deterioration. Defective components shall be removed from service. Safety nets shall also be inspected after any occurrence, which could affect the integrity of the safety net system.
8. Materials, scrap pieces, equipment and tools which have fallen into the safety net shall be removed as soon as possible from the net and at least before the next work shift.
9. The maximum size of each safety net mesh opening shall not exceed 36 square inches nor be longer than 6 inches on any side, and the opening, measured center to center of mesh ropes or webbing, shall not be longer than 6 inches. All mesh crossings shall be secured to prevent enlargement of the mesh opening.
10. Each safety net (or section of it) shall have a border rope for webbing with a minimum breaking strength of 5,000 pounds.

11. Connections between safety net panels shall be as strong as integral net components and shall be spaced not more than 6 inches apart.

Personal Fall Arrest Systems

Personal fall arrest systems and their use shall comply with the provisions set forth in OSHA CFR 1926.502. Body belts are not acceptable as part of a personal fall arrest system.



Note: The use of a body belt in a positioning device system is acceptable and is regulated under this section.

1. Connectors shall be drop forged, pressed or formed steel, or made of equivalent materials.
2. Connectors shall have a corrosion resistant finish and all surfaces and edges shall be smooth to prevent damage to interfacing parts of the system.
3. Dee rings and snaphooks shall have a minimum tensile strength of 5,000 pounds.
4. Dee rings and snaphooks shall be proof tested to a minimum tensile load of 3,600 pounds without cracking, breaking, or taking permanent deformation.
5. Snaphooks shall be sized to be compatible with the member to which they are connected to prevent unintentional disengagement of the snaphook by depression of the snaphook keeper by the connected member, or shall be a locking type snaphook, designed and used to prevent disengagement of the snaphook by the contact of the snaphook keeper by the connected member. Effective January 1, 1998 only locking type snaphooks shall be used.
6. Unless the snaphook is a locking type and designed for the following connections, snaphooks shall not be engaged:
 1. Directly to webbing
 2. To each other
 3. To a Dee ring to which another snaphook or other connector is attached
 4. To a horizontal lifeline/ or
 5. To any object which is incompatibly shaped or dimensioned in relation to the snaphook such that unintentional disengagement could occur by the connected object being able to depress the snaphook keeper and release itself.
7. On suspended scaffolds or similar work platforms with horizontal lifelines, which may become vertical lifelines, the devices used to connect to a horizontal lifeline shall be capable of locking in both directions on the lifeline.
8. Horizontal lifelines shall be designed, installed, and used, under the supervision of a Professional Engineer, as part of a complete personal fall arrest system, which maintains a safety factor of at least two.
9. Lanyards and vertical lifelines shall have a minimum breaking strength of 5,000 pounds.
10. Except as provided in this section, when vertical lifelines are used, each employee shall be attached to a separate lifeline.
11. During the construction of elevator shafts, two employees may be attached to the same lifeline in the hoistway, provided both employees are working atop a false car that is equipped with guardrails; the strength of the lifeline is 10,000 pounds (5,000 per employee attached) and all other criteria specified in this part have been met.
12. Lifelines shall be protected against being cut or abraded.

13. Self-retracting lifelines and lanyards which automatically limit free fall distance to 2 feet or less shall be capable of sustaining a minimum tensile load of 3,000 pounds applied to the device with the lifeline or lanyard in the fully extended position.
14. Self retracting lifelines and lanyards which do not limit free fall distance to 2 feet or less, ripstitch lanyards, and tearing and deforming lanyards shall be capable of sustaining a minimum tensile load of 5,000 pound applied to the device with the lifeline or lanyard in the fully extended position.
15. Ropes and straps (webbing) used in lanyards, lifelines, and strength components of body belts and body harnesses shall be made from synthetic fibers.
16. Anchorage used for attachment of personal fall arrest equipment shall be independent of any anchorage being used to support or suspend platforms and capable of supporting at least 5,000 pounds per employee attached, or shall be designed, installed, and used as follow:
 - a. As part of a complete personal fall arrest system which maintains a safety factor of at least 2
 - b. Under the supervision of a qualified person
17. Personal fall arrest systems, when stopping a fall, shall;
 - a. Limit maximum arresting force on an employee to 1,800 pounds when used with a body harness
 - b. Be rigged such that an employee can neither free fall more than 6 feet nor contact any lower level
 - c. Bring an employee to a complete stop and limit maximum deceleration distance an employee travels to 3.5 feet
 - d. Have sufficient strength to withstand twice the potential impact energy of an employee free-falling a distance of 6 feet or the free fall distance permitted y the system, whichever is less
18. The attachment point of the lanyard shall be located in the center of the wearer's back. The attachment point of the body harness shall be located in the center of the wearer's back near shoulder level, or above the wearer's head.
19. Lanyards, harnesses, and components shall be used only for employee protection as part of a personal fall arrest system or positioning device system) and not to hoist materials.
20. Personal fall arrest systems and components subjected to impact loading shall be immediately removed from service and shall not be used again or employee protection until inspected and determined by a competent person to be undamaged and suitable for reuse.
21. The employer shall provide for prompt rescue of employees in the event of a fall or shall assure that employees are able to rescue themselves.
22. Personal fall arrest systems shall be inspected prior to each use for wear, damage and other deterioration, and defective components shall be removed from service.
23. Personal fall arrest systems shall not be attached to guardrail systems nor shall they be attached to hoists except as specified in other areas of this section.
24. When a personal fall arrest system is used at hoist areas, it shall be rigged to allow the movement of the employee only as far as the edge of the walking/working surface.

Positioning Device Systems

Positioning device systems and their use shall conform to the following provisions:

1. Positioning devices shall be rigged such that an employee cannot free-fall more than 2 feet.
2. Positioning devices shall be secured to an anchorage capable of supporting at least twice the potential impact load of an employee's fall or 3,000 pounds, whichever is greater.
3. Connectors shall be drop forged, pressed or formed steel, or made of equivalent materials.
4. Connectors shall have a corrosion resistant finish, and all surfaces and edges shall be smooth to prevent damage to interfacing parts of this system.
5. Connecting assemblies shall have a minimum tensile strength of 5,000 pounds.
6. Dee rings and snaphooks shall be proof tested to a minimum tensile load of 3,600 pounds without cracking, breaking, or taking permanent deformation.
7. Snaphooks shall be sized to be compatible with the member to which they are connected to prevent unintentional disengagement of the snaphook by depression of the snaphook keeper by the unconnected member, or shall be a locking type snaphook designed and used to prevent disengagement of the snaphook by the contact of the snaphook keeper by the connected member. As of January 1, 1998, only locking type snaphooks shall be used.
8. Unless the snaphook is a locking type and designed for the following, snaphooks shall be engaged:
 - a. Directly to webbing, rope or wire rope
 - b. To each other
 - c. To a Dee ring to which another snaphook or other connector is attached
 - d. To a horizontal lifeline
 - e. To any object which is incompatibly shaped or dimensioned in relation to the snaphook such that unintentional disengagement could occur by the connected object being able to depress the snaphook keeper and release itself
9. Positioning device systems shall be inspected prior to each use for wear, damage, and other deterioration, and defective components shall be removed from service.
10. Body belts, harnesses, and components shall be used only for employee protection (as part of a personal fall arrest system or positioning device system) and not to hoist materials.

Covers

Covers for holes in floors, roofs, and other walking/working surfaces shall meet the following requirements:

1. Covers located in roadways and vehicular aisles shall be capable of supporting, without failure, at least twice the maximum axle load of the largest vehicle expected to cross over the cover.
2. All other covers shall be capable of supporting, without failure, at least twice the weight of employees, equipment, and materials that may be imposed on the cover at any one time.
3. All covers shall be secured when installed so as to prevent accidental displacement by the wind, equipment, or employees.
4. All covers shall be color-coded or they shall be marked with the word "HOLE" or "COVER" to provide warning of the hazard.



Note: This provision does not apply to cast iron manhole covers or steel grates used on streets or roadways.

Protection from Falling Objects

Falling object protection shall comply with the following provisions:

1. Toeboards, when used as falling object protection, shall be erected along the edge of the overhead walking/working surface for a distance sufficient to protect employees below.
2. Toeboards shall be capable of withstanding, without failure, a force of at least 50 pounds applied in any downward or outward direction at any point along the toeboard.
3. Toeboards shall be a minimum of 5 ½ inches in vertical height from their top edge to the level of the walking/working surface. They shall have not more than ¼ inch clearance above the walking/working surface.
4. Where tools, equipment, or materials are piled higher than the top edge of a toeboard, paneling or screening shall be erected from the walking/working surface or toeboard to the top of a guardrail system's top rail or midrail, for a distance sufficient to protect employees below.
5. Guardrail systems, when used as falling object protection, shall have all openings small enough to prevent passage of potential falling objects.
6. During the performance of overhand bricklaying and related work;
 - a. No materials or equipment except masonry and mortar shall be stored within 4 feet of the working edge.
 - b. Excess mortar, broken or scattered masonry units, and all other materials and debris shall be kept clear from the work area by removal at regular intervals.
7. During the performance of roofing work;
 - a. Materials and equipment shall not be stored within 6 feet of a roof edge unless guardrails are erected at the edge.
 - b. Materials, which are piled, grouped, or stacked near a roof edge, shall be stable and self-supporting.
8. Canopies, when used as falling object protection shall be strong enough to prevent collapse and to prevent penetration by any objects, which may fall onto the canopy.

TRAINING

Training Requirements

1. The employer shall provide a training program for each employee who might be exposed to fall hazards. The program shall enable each employee to recognize the hazards of falling and shall train each employee in the procedures to be followed in order to minimize these hazards.
2. The employer shall assure that each employee has been trained, as necessary, by a competent person qualified in the following areas;
 - c. The nature of fall hazards in the work area
 - d. The correct procedures for erecting, maintaining, disassembling, and inspecting the fall protection systems to be used
 - e. The use and operation of guardrail systems, personal fall arrest systems, safety net systems, warning line systems, safety monitoring system, controlled access zones, and other protection to be used
 - f. The role of each employee in the safety monitoring system when this system is used

- g. The limitations on the use of mechanical equipment during the performance or roofing work on low sloped roofs
- h. The correct procedures for the handling and storage of equipment and materials and the erection of overhead protection
- i. The role of the employees in fall protection plans
- j. The standards contained in this section

Certification of Training

The employer shall verify compliance with item #1 under Training Requirements by preparing a written certification record. The written certification record shall contain the name or other identity of the employee trained, the dates(s) of the training, and the signature of the person who conducted the training or the signature of the employer. If the employer relies on training conducted by another employer or completed training prior to the effective date of this section, the certification record shall indicate the date the employer determined the prior training was adequate rather than the date of the actual training.

The latest training certification shall be maintained.

Retraining

When the employer has reason to believe any affected employee who has already been trained does not have the understanding and skill required by this section, the employer shall retrain each such employee.

Circumstances where retraining is required include, but are not limited to, situations where:

- 1. Changes in the workplace render previous training obsolete
- 2. Changes in the types of fall protection systems or equipment to be used render previous training obsolete
 - 1. Inadequacies in an affected employee's knowledge or use of fall protection systems or equipment indicate that the employee has not retained the requisite understanding or skill

Part 10: Fire Protection

INTRODUCTION

On School Construction Authority Projects where Fire Standards are required the Federal OSHA Standards, current New York City Department of Buildings Codes, New York City Fire Department and School Construction Authority Safety Program & Procedures Manual and any other governing agencies laws, regulations, and procedures shall be adhered to. The most stringent of these standards shall be applicable.

BASIC TERMINOLOGY

Definitions for the following terms are listed alphabetically within the Glossary located at the back of this publication:

- Approved
- Close Container
- Combustible Liquid
- Combustion
- Fire Brigade
- Fire Resistance
- Flammable
- Hot Work
- Flammable Liquid
- Flash Point
- Liquefied Petroleum Gases (LPG) or (LP)
- Portable Tank
- Safety Can
- Vapor Pressure
- Fire Guard



SCA GENERAL REQUIREMENTS

1. Full compliance with New York City Building Codes and Rules of the City of New York: Title 3 Fire Department Rules, New York City Fire Code and all other applicable laws, rules and regulations shall be enforced
2. No School exits/entrances or Holding areas shall be obstructed/altere d or blocked without prior approval from FDNY. This may also require the filing of an alternate evacuation plan with the DOB.
3. NYC Fire Department inspection deficiencies shall be corrected immediately
4. Temporary heat shall be permitted on *Line Project* with proper Permits from the New York City Fire Department. All FDNY rules and regulations shall apply. GC to submit a temporary heating

plan to Safety Unit for review prior to use of temporary heat. See sample checklist included herein for temporary heating plan requirements.

5. CIP Projects requires a written Temporary Heating Plan Procedure to be designed and submitted to the SCA Safety Unit prior to use. The following minimum information shall be included in the plan: Type of equipment to be used, Trained Fireguard, manufacturers use and instructions, clearly defined fire exits/egress, ventilation for Carbon Monoxide emissions, permits for use. All FDNY rules and regulations shall apply. See sample checklist of requirements at the end of this part.
6. Housekeeping shall take place daily on all *schools* and the debris removed from the *school* premise
7. No open flame is permitted on any New York City School Projects, including but not limited to open 55-gallon drums
8. Heaters with open flames are not permitted for use.
9. A permit from FDNY is required to conduct hot work using oxygen and a flammable gas
10. All permits for storage, use and handling of hazardous materials or combustible materials shall be obtained from the FDNY
11. Hot Work shall not take place on any School Construction Authority project when the school premise is occupied.
12. The storage of compressed gas cylinders or LPG gas cylinders on occupied school is not permitted
13. Prior to any Hot Work activity, 48 Hour notification shall be made to the SCA Safety Officer to schedule a site meeting to review SCA, FDNY and DOB regulations.
14. A Stop Work Order shall be issued for any deficiencies noted in the safety procedures for Hot Work and a licensed NYC Site Safety Manager will be required for remainder of such hot work.
15. Fire Guards shall prepare and sign an inspection report confirming safety condition of the premises. Such logs shall be readily available for inspection.
16. A Fire Watch is to make hourly rounds when temporary heating devices are in operation and such hourly rounds are to be documented.
17. Fire watch shall inspect scaffolding and sidewalk bridging at end of each shift including perimeter of school.

FIRE PROTECTION

General Requirements

1. The contractor shall be responsible for the development of a fire protection program, as it applies to the scope of work, to be followed throughout all phases of the construction and demolition work, and they shall provide for the firefighting equipment as specified in this subpart. As fire hazards occur, there shall be no delay in providing the necessary equipment.
2. Recommended practices and standards of the National Fire Protection Association (NFPA) and other applicable regulations, including the NYC Fire Code and FDNY F.P. MANUAL CH.3 INSPECTIONAL GUIDE 7 Titled “ BUILDINGS UNDER CONSTRUCTION AND DEMOLITION”, shall be followed in the development and application of Project Fire Protection Programs. Essential considerations for the Fire Protection Plan must include:
 - a. Proper site preparation.
 - b. Availability of private and public fire protection.
 - c. Safe installation and protection of temporary buildings and other structures.

- d. Adequate job site fire protection.
 - e. Minimizing inherent construction fire hazards.
 - f. Installation of permanent safeguards as construction progresses.
 - g. Adequate indoctrination of employees.
3. While working in an occupied or existing school property the contractor must adhere to and work within the existing Fire Protection Plan of the building.
 4. Exit doors throughout the premise are not permitted to be permanently closed, altered, locked or blocked by the school, contractor or SCA without first obtaining an on site inspection with written approval from the New York City Fire Department.
 5. In those schools which have “holding areas (Architectural Barrier Rooms;ABR)” safe access shall be provided and maintained in accordance with local FDNY requirements.

Tar Kettle Use

1. Roofing activities which require the use of a Tar Kettle shall file for a City Wide Permit. This permit is issued by the Fire Commissioner. The permit is valid for one year. A city-wide permit may be obtained for tar kettle operations. Renewal for the City Wide Permit shall be in accordance with the New York City Fire Department. The permit must be presented to any Fire Department representative upon request. The Permit is to be posted and readily available on site for review.
2. The Tar Kettle shall be inspected and tagged with an inspection tag from the New York City Fire Department.
3. In accordance with NYC Fire Code (NYC Administrative Code, Title 29); Tar kettles shall not be utilized inside or on the roof of a building or structure.
 4. All users of the Tar Kettle and/or Torches shall obtain a current Certificate of Fitness from the New York City Fire Department and shall comply with the following:
 5. Only Interstate Commerce Commission shipping cylinders not exceeding 100 pounds capacity shall be used as container for the liquefied petroleum gas.
 6. Only gas heaters approved by the Board of Standards and Appeals, and so labeled, shall be used.
 7. The handling of the liquefied petroleum gas cylinders and the operation of the heating device shall be under the supervision of a person holding a Certificate of Fitness. Applicants for certificate of fitness for handling liquefied petroleum gas as a fuel for heating tar kettles and the operation of heating device shall file with the fire department, as part of his application, a certification that he has satisfactorily completed a course of instruction acceptable to the fire department in relation to handling and safeguarding such fuel.
 8. The connecting of liquefied petroleum gas cylinders to tar kettle unit shall be conducted outdoors.
 9. Liquefied petroleum gas cylinders in use shall be adequately supported in an upright position and safeguarding such fuel.
 10. No excess cylinders shall be stored on job site.
 11. Each portable tar kettle unit shall be provided with an extinguisher of the Carbon Dioxide or Dry Chemical type containing at least four (4) pounds of extinguishing agent of sufficient pails of sand.
 12. It shall be unlawful for any person to operate, maintain or use a kindled tar kettle

- a. In any building or on roofs or any structure unless roof is of incombustible construction
 - b. Within 15 feet of a hydrant
 - c. Within 2 feet of the surface of any asphalt pavement except for the purpose of repairing, removing or construction same.
 - d. On or within 2 feet of the surface of any asphalt pavement except for the purpose of repairing, removing or construction of same.
 - e. Without a pressure regulator and excess flow check valve approved by the Underwriters laboratories and/.or Board of Standards and Appeals; also provided with a shut off valve at the cylinder.
13. The Division of Fire Prevention shall be notified in writing at least 48 hours in advance at any job location.
 14. City Wide Permit or copy of such permit shall be available at each job location site for inspection by the Fire Department.
 15. A Permit shall be obtained when required to store and use fuel for heating tar kettles in accordance with Chapter 4 of Title 27 of the Administrative Code.
 16. Hot Work *shall not* take place on any School Construction Authority project when the school premise is occupied.

Housekeeping and Clean-Up

1. Daily cleanup of scrap material, sawdust, rags, oil, paint, grease, flammable solvents and other residue of construction operations is required.
2. All construction areas and storage yards shall be cleared of combustible materials before lumber and other combustible construction materials are delivered to the jobsite.
3. Access to all available firefighting equipment shall be maintained at all times.

Portable Firefighting Equipment - Fire Extinguishers

1. A fire extinguisher, rated not less than 2A, shall be provided for each 2,500 *square feet* of the protected building area, or major fraction thereof (*as per FDNY Fire Code*). Travel distance from any point of the protected area to the nearest fire extinguisher shall not exceed 75 *feet* (*as per FDNY Fire Code*).
2. All fire fighting equipment provided by the employer shall be conspicuously located. Access to all available fire fighting equipment shall be maintained at all times.
3. One 55-gallon open drum of water with two fire pails may be substituted for a fire extinguisher having a 2A rating.
4. One or more fire extinguishers rated not less than 2A shall be provided on each floor. In multi-story buildings, at least one fire extinguisher shall be located adjacent to stairway.
5. Extinguishers and water drums shall be protected from freezing.
6. Where more than 5 gallons of flammable or combustible liquids or 5 pounds of flammable gas are being used, a fire extinguisher rated not less than 10B shall be provided within 50 feet unless required otherwise.
7. Carbon tetrachloride and other toxic vaporizing liquid fire extinguishers are prohibited.

8. Portable fire extinguishers shall be inspected and maintained at least once every six (6) months. All inspections must also be recorded on a tag attached to the extinguisher. All extinguishers must be recharged every six (6) months or after each use. All portable fire extinguishers shall be maintained in accordance with Maintenance and Use of Portable Fire Extinguishers, NFPA No. 10A.
9. Fire extinguishers which have been listed or approved by a nationally recognized testing laboratory shall be used to meet the requirements of this subpart.
10. As structures are completed, fire extinguishers will be provided where needed. Recharging will be done by a licensed contractor as required.
11. When welding and burning, provide water hose.

FLAMMABLE AND COMBUSTIBLE LIQUIDS

General Requirements

1. Only approved containers and portable tanks shall be used for storage and handling of flammable and combustible liquids. Approved metal safety can shall be used for the handling and use of flammable liquids in quantities greater than one gallon, except that this shall not apply to those flammable liquid materials which are highly viscous (extremely hard to pour) which may be used and handled in original shipping containers. For quantities of one gallon or less, the original container or approved metal safety cans shall be used for storage, use and handling of flammable and combustible liquids.
2. An approved metal safety can is a metal can with a flash arresting screen, spring closing lid and properly labeled with its contents.
3. Metal safety cans are to be colored as follows;
 - a. Red = gasoline
 - b. Blue = kerosene
 - c. Yellow = diesel
4. Flammable or combustible liquids shall not be stored in areas used for exits, stairways or normally used for the safe passage of people.

Indoor Storage of Flammable and Combustible Liquids

1. Not more than 25 gallons of flammable or combustible liquids shall be stored in a room outside of an approved storage cabinet.
2. Quantities of flammable and combustible liquid in excess of 25 gallons shall be stored in an acceptable room or approved metal cabinet.
3. Not more than 60 gallons of flammable or 120 gallons of combustible liquids shall be stored in any one storage cabinet. Not more than three such cabinets may be located in a single storage area.
4. Materials which will react with water and create a fire hazard shall not be stored in the same room with flammable or combustible liquids.
5. Flammable and combustible liquids in excess of the permitted quantities specified shall be stored off-site or outside of buildings in accordance with paragraph (3) of this section.

Storage Outside Buildings

1. Storage of containers (not more than 60 gallons each) shall not exceed 1,100 gallons in any one pile or area. Piles or groups of containers shall not be nearer than 20 feet to a building.
2. Within 200 feet of each pile of containers, there shall be a 12-foot wide access way to permit approach of fire control apparatus.
3. The storage area shall be graded in a manner to divert possible spills away from buildings or other exposures or shall be surrounded by a curb or earth dike at least 12 inches high. When curbs or dikes are used, provisions shall be made for draining off accumulations of ground or water or spills or flammable or combustible liquids. Drains shall terminate at a safe location and shall be accessible to operation under fire condition.

Outdoor Portable Tank Storage

1. Portable tanks shall not be nearer than 20 feet from any building. Two or more portable tanks grouped together having a combined capacity in excess of 2,200 gallons shall be separated by a 5-foot clear area. This shall not apply to occupied schools)
2. Within 200 feet of each portable tank, there shall be a 12-foot wide access way to permit approach of fire control apparatus.
3. Conspicuous and legible signs prohibiting smoking and open flame shall be posted on all flammable and combustible liquid storage tanks.
4. Storage areas shall be kept free of weeds, debris and other combustible material not necessary to the storage.
5. All Portable tanks shall be provided with emergency venting and other devices as required by Chapters III and IV of NFPA 30-1969, the Flammable and Combustible Liquids Code.

Fire Control for Flammable or Combustible Liquids Storage

1. At least one portable fire extinguisher having a rating of not less than 20- B units shall be located outside of, but not more than 10 feet from, the door opening into any room used for storage of more than 60 gallons of flammable or combustible liquids.
2. At least one portable fire extinguisher having a rating of not less than 20- B units shall be located not less than 25 feet nor more than 75 feet from the flammable liquid storage area located outside.
3. At least one portable fire extinguisher having a rating of not less than 20- B: C units shall be provided on all tank trucks or other vehicles used for transporting and/or dispensing flammable or combustible liquids.

Handling Liquids at Point of Final Use

1. Flammable liquids shall be kept in closed and approved containers when not actually in use.
2. Leakage or spillage of flammable or combustible liquids shall be disposed of promptly and safely.

Liquefied Petroleum Gas (LPG) - Approval of Equipment and Systems

1. Each system shall have containers, valves, connectors, manifold valve assemblies and regulators of an approved type.
2. All cylinders shall meet the Department of Transportation specification identification requirements published in 49CFR Part 178, Shipping Container Specification.

Welding on LPG Containers

Welding is prohibited on LPG containers.

Container Valves and Container Accessories

1. Valves, fittings and accessories connected directly to the container, including primary shutoff valves, shall have a rated working pressure of at least 250 psg and shall be of material and design suitable for LPG service.
2. Connections to containers, except safety relief connections, liquid level gauging devices and plugged openings shall have shutoff valves located as close to the container as possible.

Safety Devices

1. Every container and every vaporizer shall be provided with one or more approved safety relief valves or devices. These valves shall be arranged to afford free vent to outer air with discharge not less than 5 feet horizontally away from any opening into a building which is below such discharge.
2. Shutoff valves shall not be installed between the safety relief device and the container or the equipment or piping to which the safety relief device is connected except that a shutoff valve may be used where the arrangement of this valve is such that full required capacity flow through safety relief device is always afforded.
3. Container safety relief devices and regulatory relief vents shall be located not less than 5 feet in any direction from air openings into sealed combustion system appliances or mechanical ventilation air intakes.

Dispensing

Filling of fuel containers on site is prohibited.

Requirements for Appliances

1. LPG consuming appliances shall be approved types.

Containers and Regulating Equipment Installed Outside of Building or Structures

Containers shall be upright upon firm foundations and firmly secured. The possible effects on the outlet piping or settling shall be guarded against by a flexible connection or special fitting.

Containers and Equipment Used Inside of Buildings or Structures

1. When operational requirements make portable use of containers necessary and their location outside of buildings or structures is impracticable, containers and equipment shall be permitted to be used inside of buildings or structures in accordance with subparagraphs (b) through (k) of this paragraph. A fire watch is required for all hot-work involving compressed gas.
2. "Containers in use" means connected for use.
3. Systems utilizing containers having a water capacity greater than 2½ pounds (nominal 1 pound LPG capacity) shall be equipped with excess flow valves. Such excess flow valves shall be either integral with the container valves or in the connections to the container valve outlets.

4. Regulators shall be either directly connected to the container valves or to manifolds connected to the container valves. The regulator shall be suitable for use with LPG. Manifolds and fittings connecting containers to pressure regulator inlets shall be designed for at least 250 psg service pressure.
5. Valves on containers having water capacity greater than 50 pounds (nominal 20 pounds LPG capacity) shall be protected from damage while in use or storage.
6. Aluminum piping or tubing shall not be used.
7. Hose shall be designed from a working pressure of at least 250 psg. Design, construction and performance of hose and hose connections shall have their suitability determined by listing by a nationally recognized testing agency. The hose length shall be as short as practicable. Hoses shall be long enough to permit compliance with spaced provisions of subparagraphs (a) through (m) of this paragraph without kinking or straining or causing hose to be so close to a burner as to be damaged by heat.
8. Portable heaters, including salamanders, shall be equipped with an approved automatic device to shut off the flow of gas to the main burner and pilot if used in the event of flame failure. Such heaters having inputs above 50,000 B.T.U. per hour shall be equipped with either a pilot which must be lighted and proved before the main burner can be turned on or an electrical ignition system. Contractor to ensure proper ventilation for workers during use of temporary heat.



Note: The provisions of this subparagraph do not apply to portable heaters under 750 B.T.U. per hour input when used with containers having a maximum water capacity of 2½ pounds.

9. Container valves, connectors, regulators, manifolds, piping and tubing shall not be used as structural supports for heaters.
10. Containers, regulating equipment, manifolds, pipe, tubing and hose shall be located to minimize exposure to high temperatures or physical damage.
11. Containers having a water capacity greater than 2½ pounds (nominal 1 pound LPG capacity) connected for use shall stand on a firm and substantially level surface and shall be secured in an upright position.
12. The maximum water capacity of individual containers shall be 245 pounds (nominal 100 pounds LPG capacity).
13. For temporary heating, heaters (other than integral heater-container units) shall be located at least 6 feet from any LPG container. This shall not prohibit the use of heaters specifically designed for attachment to the container or to a supporting standard provided that they are designed and installed so as to prevent direct or radiant heat application from the heater onto the containers. Blower and radiant type heaters shall not be directed toward any LPG container within 20 feet.
14. If two or more heater-container units of either the integral or non-integral type are located in an unpartitioned area on the same floor, the container or containers of each unit shall be separated from the container or containers of any other unit by at least 20 feet.
15. When heaters are connected to containers for use in an unpartitioned area on the same floor, the total water capacity of containers manifolded together for connection to a heater or heaters shall not be greater than 735 pounds (nominal 300 LPG capacity). Such manifolds shall be separated by at least 20 feet.
16. Storage of containers awaiting use shall be in accordance with paragraphs (10) and (11) of this section.

Container Valves and Accessories

1. Valves in the assembly of multiple container systems shall be arranged so that replacement of containers can be made without shutting off the flow of gas in the system. This provision is not to be construed as requiring an automatic changeover device.
2. Heaters shall be equipped with an approved regulator in the supply line between the fuel cylinder and the heater unit. Cylinder connectors shall be provided with an excess air flow valve to minimize the flow of gas in the event the fuel line becomes ruptured.
3. Regulators and low-pressure relief device shall be rigidly attached to the cylinder valves, cylinders, supporting standards, the building walls or otherwise rigidly secured and shall be so installed or protected from the elements.

Storage of LPG Containers

1. Storage of LPG within buildings is prohibited.
2. Storage of LPG below grade is prohibited.

Storage Outside of Buildings

Storage of LPG shall be in accordance with New York City Fire Codes.

* LPG cylinders shall be stored in manner and number as specified by the Fire Department Permit. In no case shall the number of cylinders exceed the amount permitted whether they are located within the storage facility or elsewhere on the construction site.

Clearance and Mounting

1. Ventilation – Fresh air shall be supplied in sufficient quantities to maintain the health and safety of workmen. Where natural means of fresh air supply is inadequate, mechanical ventilation shall be provided.
2. Temporary heating devices shall be installed to provide clearance to combustible material not less than 36”.
3. Temporary heating devices which are listed for installation with lesser clearances may be installed in accordance with the approval of the NYCSCA.
4. Heaters not suitable for use on wood floors shall not be set directly upon them or other combustible materials. When such heaters are used, they shall rest on suitable heat insulating material or at least 1-inch concrete or equivalent. The insulating material shall extend beyond the heater two (2) feet or more in all directions.
5. Heaters used in the vicinity of combustible tarpaulins, canvas or similar coverings shall be located at least 10 feet from the coverings. The coverings shall be securely fastened to prevent ignition or upsetting of the heater due to wind action on the covering or other material.

Stability

When in use, heaters shall be set horizontally level unless otherwise permitted by the manufacturer's markings.

Solid Fuel Heater

Solid fuel heaters are prohibited.

Oil-Fired Heaters

1. Flammable liquid-fired heaters shall be equipped with a primary safety control to stop the flow of fuel in the event of flame failure. Barometric or gravity oil feed shall not be considered a primary safety control.
2. Heaters designed for barometric or gravity oil feed shall be used only with integral tanks.
3. Heaters which are not designed for flue connection shall be equipped with integral tanks having capacity of not more than two (2) gallons.
4. Heaters specifically designed and approved for use with separate supply tanks may directly connected for gravity feed or an automatic pump from a supply tank.

SPRINKLER AND STANDPIPE REQUIREMENTS

STANDPIPES – Building Code Section 3303.8 requires a standpipe when in the course of erection or demolition the building reaches a height of 75 feet with a floor system in place.

Standpipes in building under construction and demolition shall be maintained as dry systems

When demolition is started, the standpipe risers shall be capped above the outlet on the floor below the floor being demolished so as to maintain the standpipe system on all lower floors for Fire Department Use.

SPRINKLERS – In structures undergoing demolition that have existing sprinkler systems with Siamese connections such systems shall be maintained as a non-automatic sprinkler system.

Removal of damaged sprinkler systems in buildings undergoing demolition or gut rehabs – The Department of Buildings and the FDNY have established a uniform procedure, known as a Technical Policy and Procedure Notice (TPPN 3/07), to process variance requests for the removal of damaged existing sprinkler systems in buildings undergoing demolition or gut rehab.

TEMPORARY ELEVATOR OR HOIST

Whenever construction or demolition work reaches a height greater than 75 feet, at least one elevator meeting the requirements of Chapter 30 of the NYC Building Code, or a hoist meeting the requirements of Building Code Section 3318 shall be kept in readiness at all times for Fire Department use.

Enforcement – Failure to provide an elevator in readiness in accordance with Building Code 3303.12 and 3318, RCNY Title 27 Section 27-4270 and BSA Chapter 3 Construction 3-02 shall result in the issuance of a Violation Order by the FDNY.

REQUIREMENTS FOR FIRE GUARDS

Fire guards require a Certificate of Fitness from the FDNY

Fire guards are required at sites when construction, alteration or demolition exceeds 10,000 square feet when fronting one street, or 20,000 square feet when fronting two streets or whenever the building exceeds 75 feet in height.

When the construction, alteration or demolition site exceeds 10,000 square feet or 20,000 square feet and is completely enclosed by a substantial fence, the area limitations shall be increased by 50 percent to therefore require one fire guard per 15,000 square feet when fronting one street or one fire guard per 30,000 square feet when fronting two streets.

Fire guards shall be on duty when operations are not in progress. Therefore, when construction workers quit for the day, fire guards must be present onsite from end of construction workers' day until 2400 hours. Between 2400 hours and 0800 hours, fire guards are not required to be present. During these hours a competent Watch Person shall be present.

Fire guards must maintain a log of their inspections/patrols of the building site. Patrols should be conducted hourly and cover all areas of the building.

The log must be present for FDNY inspecton at the site and contain the results of inspections, any deficiencies discovered and the name of the fire guard who conducted the inspections.

REQUIREMENTS FOR WATCH PERSON SERVICES

Watch person service is to be conducted by a competent person. No certificate of fitness or other documentation is required by FDNY

A competent watch person shall be on duty during all hours when operations are not in progress or fire guards are not present.

A single watch person shall be present when a building being constructed or demolished occupies an area of 5,000 square feet upto 40,000 square feet. If the area is greater than 40,000 square feet, an additional watch person shall be on premises.

Watch persons shall know the location of the nearest fire alarm box and transmit an alarm to the FDNY immediately upon any indication of fire.

REQUIREMENT S FOR PORTABLE FIRE APPLIANCES

For each 2,500 square feet of construction or 5,000 square feet of demolition of floor area, provide on each floor one 21/2 gallon water type extinguisher. A building that has a permit for alteration must comply with the more stringent requirement of one portable fire appliance per 2,500 square feet.

Provide one 21/2 gallon water type extinguisher on each floor where wood scaffold has been erected to a height greater than 40 feet. This extinguisher shall be readily accessible to the scaffold.

Part 10 Checklist: Temporary Heating Plan

Minimum Requirements for temporary heating plan

- ✓ List reason for use of heat/ purpose (Curing, brickwork, masonry, spackling etc.)
- ✓ Type of heating device(s), and fuel type to be used (Manufactures tear sheet and specifications should be included)
- ✓ Type(s) of tarps or enclosures to be used if applicable (Brand name and fire rating)
- ✓ List all FDNY certificates of fitness for handling fuels / cylinders required for task.
- ✓ Number of continuous fire guards to be used
- ✓ Statement of responsibility to obtain ALL necessary FDNY permits for use storage, etc.
- ✓ Define ventilation equipment used
- ✓ Brief outline of day to day activity, fire guard duties, fire fighting equipment etc.

All contractors will assure proper monitoring of fume accumulations and air quality as a result of temporary heating devices. Contractor will be responsible for proper ventilation and (or) air monitoring to provide acceptable breathing environment for ALL parties in the building during all hours of operation.

Part 10 Appendix A: Enforcement of Smoking Prohibition



FIRE PREVENTION MANUAL CHAPTER 12, FPIB 47 September 16, 2008

ENFORCEMENT OF SMOKING PROHIBITION AT CONSTRUCTION SITES (NEW YORK CITY FIRE CODE SECTION 1404.1)

The following is hereby promulgated for the information and guidance of Department personnel.

- 1) As per Section 1404.1 of the new Fire Code (FC1404.1), effective July 1, 2008, smoking on any construction site is strictly prohibited. "Construction site" is defined by FC1402.1 to include any building under construction, alteration or demolition.
- 2) Department personnel shall issue a summons immediately whenever they personally witness any individual smoking at a construction site. The person smoking shall receive the summons.
- 3) In addition, a Notice of Violation (NOV) shall be issued to the Department of Buildings Work Permit Holder or the owner of the building, as follows:
 - The NOV shall cite Violation Category 11 (General Maintenance) (formerly Rule 11), which shall be completed to read: "Failed to maintain the construction site in compliance with general maintenance requirements."
 - The Description of the Violation shall note that smoking was observed in violation of FC1404.1, the location it was observed, and the following remedy: "A responsible official of respondent shall submit to the Fire Department a sworn and notarized corrective action plan setting forth the actions that will be taken to prevent smoking on the construction site."
- 4) Such an NOV shall be issued, even in the absence of observed smoking, when there is evidence of smoking at a construction site, such as cigarette or cigar butts or smoke.
- 5) The NOV shall be deemed "cured" if a satisfactory corrective action plan is timely submitted to the Bureau of Fire Prevention that sets forth reasonable actions to prevent smoking on the construction site, such as (but not limited to) the items listed in Paragraph 7 below. A second or subsequent (repeat) violation for smoking on the same construction site shall not be curable.
- 6) Where NO SMOKING signs are not posted at construction sites, as required by FC310.3, Department personnel shall also issue an NOV for failure to post such required signs. The NOV shall cite Violation Category 6 (Signs, Postings, Notices and Instructions) (formerly Rule 6), which shall be completed to read: "Failed to provide and/or maintain signs for 'No Smoking' at construction site."

- 7) In addition, in order to ensure compliance with the above provisions, Department personnel should strongly recommend that contractors, sub-contractors and appropriate site safety personnel take the following actions to prevent smoking on construction sites:
- Remove all ashtrays or similar devices for cigarette or cigar butts.
 - Inform individuals smoking on the site that they are not in compliance with the law and may be subject to fines and penalties.
 - Instruct individuals found smoking to immediately extinguish any smoking materials.

BY ORDER OF THE FIRE COMMISSIONER AND CHIEF OF DEPARTMENT

Part 10 Checklist: Hot Work Checklist

Hot Work Checklist

Hot Work to be defined as any work that can give off a source of ignition, or that in any way can start a fire. Be sure to check the following:

- ✓ The Project Officer has notified the Safety Unit 48 Hours prior to the start of any and all Hot Work. Notification to Director and SCA Safety Inspector.
- ✓ Job Meeting with the following set up:
 - SCA Safety Officer
 - SCA Project Officer
 - GC Designated Competent Site Supervisor
 - Licensed Welder, the torch operator
 - Fire Guard(s)
 - Site Safety Manager or Safety Coordinator if applicable.
 - Forman or Site Supervisor
- ✓ The following is checked:
 - Masonry or any anchors or accessories welded or mechanically fastened
 - Conditions that could result in hot work at later date are considered
 - Location of work and potential exposures are explored
 - Installation and size of fire blankets are appropriate
 - Participants are aware that if fire is found, they should notify FDNY via 911 before attempting to extinguish
 - Participants are aware of the location of fire suppression equipment
 - Leaves and combustible debris are removed from sidewalk shed.
 - Scaffold and Components - scaffold and sidewalk shed planks can harbor slag for hours
 - Vertical debris netting is REQUIRED to be fire retardant.
 - Combustible building materials must be stored properly and removed from welding areas
 - Ensure that scaffold stair tower and second means of egress meet the minimum criteria.
 - Roof access via stairs
- ✓ OSHA, SCA, NYC DOB, FDNY minimum standards are met
 - Welders: NYC DOB issued welding license
 - Fire Guard Persons: FDNY Certificate of fitness
 - Roofers: citywide permit
- ✓ School Occupancy
 - Only custodial staff to be in building
 - Ensure that GC PM and SCA PO have coordinated with principal as to regular and after hours school programs. NO WELDING OR BURNING OR OPEN FLAME ON SCHOOL SITE WHILE CHILDREN OR TEACHERS ARE IN SCHOOL.
 - Method of notification between custodial staff and contractor in the event of an emergency.
- ✓ Required on Site Documentation
 - Fire guard logs maintained and readily available on site.
 - SCA Pre Hot Work Inspection record.
 - Once a week hot work tool box meeting while such work ongoing
 - Fire protection and evacuation plan
 - Records of routine fire suppression equipment maintenance and inspection.
- ✓ Fire Guard Person
 - Knowledge of Fire Blankets and suppression equipment
 - Responsible to notify employer of the need for correct Fire Protection accessories and equipment if lacking
 - If new to Job, must attend orientation meeting and be familiar with log procedure
 - Must be familiar with job specific exposures and concerns
 - FDNY Notification, Must Have cell phone and call 911 before attempting to extinguish fire.
- ✓ Fire equipment present at immediate work site.
- ✓ Fire Guard
 - Inspect at least 2 hours after welding or cutting work is complete as per FDNY requirements.
 - Fire watch is ONLY duty of Fire Guard
 - Every floor below the work is a possible exposure
 - Remove combustible material before allowing work to start
 - Notify FDNY when required

Part 10 Checklist: Pre-Roofing Safety Checklist

Pre-Roofing Safety Checklist:

- ✓ Corporate Health and Safety Program required for Roofing subcontractor
- ✓ Corporate Health and Safety Program required for All other Subcontractors such as Asbestos Contractor
- ✓ Site Specific Fall protection program from roofing subcontractor showing building layout and type of fall protection that will be used
- ✓ 48 Hour notification must be made to the SCA Safety Unit prior to any hot work activity to schedule a site meeting.
- ✓ Documented training in Fall protection for Roofing and other (asbestos) subcontractors
- ✓ Local Law 52 – 4 hour user certification required for all workers who will be using the supported pipe frame scaffold to access the roof.
- ✓ Use of tar kettle – need citywide permit from FDNY, Certificate of fitness for operator and fire guard, Tar kettle not permitted on roof, propane storage not permitted overnight. If tanker is being used, area to be barricaded, flagmen to be used to direct pedestrian and vehicular traffic.
- ✓ All roof vents/exhausts to be sealed, to prevent fumes from entering the building.
- ✓ Roof hoist – requires a CD-5 from DOB. Any other hoisting equipment must be installed and operated as per manufacturer's specifications.
- ✓ If a truck crane is to be used to hoist material all required documentation detailed in the Crane and Derricks section of the Safety Manual must be provided prior to crane arriving onsite.
- ✓ All the safety documentation must be submitted prior to start of roof work

Part 11: Hand & Power Tools

INTRODUCTION

On school Construction Authority Projects where a crane, derrick, hoist or elevator is used Federal OSHA Standards, New York City Department of Building Codes and School Construction Authority Procedures shall be implemented. The most stringent of these standards shall be applicable.



SCA GENERAL REQUIREMENTS

1. When using powder-actuated tools training documentation from the manufacturer and the New York City Fire Department Certificate of Fitness shall be provided for each type of powder-actuated tool used.
2. Guards shall be used on all power operated grinding tools as provided
3. Personal Protective equipment such as but not limited to eye protection, hearing protection and hand protection are to be used during the operation of tools

GENERAL REQUIREMENTS

Condition of Tools

All hand and power tools and similar equipment, whether furnished by the employer or the employee, shall be maintained in a safe condition.

Guarding

When power operated tools are designed to accommodate guards, they shall be equipped with such guards when in use.

Belts, gears, shafts, pulleys, sprockets, spindles, drums, fly wheels, chains, or other reciprocating, rotating or moving parts of equipment shall be guarded if such parts are exposed to contact by employees or otherwise create a hazard.

Guarding shall meet the requirements as set forth in American National Standards Institute, B15.1-1953 (R1958), Safety Code for Mechanical Power-Transmission Apparatus.

Types of Guarding

One or more methods of machine guarding shall be provided to protect the operator and other employees in the machine area from hazards such as those created by point of operation, ingoing nip points, rotating parts, flying chips and sparks.



Example: Barrier guards, two-hand tripping devices, and electronic safety devices.

Point of Operation Guarding

1. Point of operation is the area on a machine where work is actually performed upon the material being processed.
2. The point of operation of machines whose operation exposes an employee to injury, shall be guarded. The guarding device shall be in conformity with any appropriate standards therefore, or, in the absence of applicable specific standards, shall be so designed and constructed as to prevent the operator from having any part of his body in the danger zone during the operating cycle.
3. Special hand tools for placing and removing material shall be such as to permit easy handling of material without the operator placing a hand in the danger zone. Such tools shall not be in lieu of other guarding required by this section, but can only be used to supplement protection provided.
4. The following are some of the machines which usually require point of operation guarding:
5. Guillotine cutters, Shears, Alligator shears, Powered presses, Milling machines, Power saws, Jointers, Portable power tools, Forming rolls and calendars.

Exposure of Blades

1. When the periphery of the blades of a fan is less than 7 feet (2.128 m) above the floor or working level, the blades shall be guarded. The guard shall have openings no larger than 1/2 inch (1.27 cm).
2. "Anchoring fixed machinery." Machines designed for a fixed location shall be securely anchored to prevent walking or moving.

Guarding of Abrasive Wheel Machinery - Exposure Adjustment

Safety guards of the types described in the *Bench and Floor Stands* and *Cylindrical Grinders* sections, where the operator stands in front of the opening, shall be constructed so that the peripheral protecting member can be adjusted to the constantly decreasing diameter of the wheel.

The maximum angular exposure above the horizontal plane of the wheel spindle as specified in paragraphs *Bench and Floor Stands* and *Cylindrical Grinders* of this section shall never be exceeded, and the distance between the wheel periphery and the adjustable tongue or the end of the peripheral member at the top shall never exceed 1/4 inch (0.635 cm).

Bench and Floor Stands

OSHA CFR 1926 Subpart I

The angular exposure of the grinding wheel periphery and sides for safety guards used on machines known as bench and floor stands should not exceed 90 deg. or one-fourth of the periphery. This exposure shall begin at a point not more than 65 deg. above the horizontal plane of the wheel spindle.

The following figures show the correct angular exposure of the grinding wheel periphery and sides for safety guards used on machines known as bench and floor stands.

Cylindrical Grinders

OSHA CFR 1926 Subpart I

The maximum angular exposure of the grinding wheel periphery and sides for safety guards used on cylindrical grinding machines shall not exceed 180 deg.. This exposure shall begin at a point not more than 65 deg. above the horizontal plane of the wheel spindle.

PERSONAL PROTECTIVE EQUIPMENT

Employees using hand and power tools and exposed to the hazard of falling, flying, abrasive, and splashing objects, or exposed to harmful dusts, fumes, mists, vapors, or gases shall be provided with the particular personal protective equipment necessary to protect them from the hazard. All personal protective equipment shall meet the requirements and be maintained according to Subparts D and E of 29 CFR Part 1926.

SWITCHES

All hand-held powered platen sanders, grinders with wheels 2-inch diameter or less, routers, planers, laminate trimmers, nibblers, shears, scroll saws, and jigsaws with blade shanks one-fourth of an inch wide or less may be equipped with only a positive "on-off" control.

All hand-held powered drills, tappers, fastener drivers, horizontal, vertical, and angle grinders with wheels greater than 2 inches in diameter, disc sanders, belt sanders, reciprocating saws, saber saws, and other similar operating powered tools shall be equipped with a momentary contact "on-off" control and may have a lock-on control provided that turnoff can be accomplished by a single motion of the same finger or fingers that turn it on.

All other hand-held powered tools, such as circular saws, chain saws, and percussion tools without positive accessory holding means, shall be equipped with a constant pressure switch that will shut off the power when the pressure is released. The requirements of this paragraph became effective on July 15, 1972.



Attention: Switches do not apply to concrete vibrators, concrete breakers, powered tampers, jack hammers, rock drills, and similar hand operated power tools.

HAND TOOLS

1. Employers shall not issue or permit the use of unsafe hand tools.
2. Wrenches; including adjustable, pipe, end, and socket wrenches shall not be used when jaws are sprung to the point that slippage occurs.
3. Impact tools, such as drift pins, wedges, and chisels, shall be kept free of mushroomed heads.
4. The wooden handles of tools shall be kept free of splinters or cracks and shall be kept tight in the tool.

ELECTRIC POWER-OPERATED TOOLS

1. Electric power operated tools shall either be of the approved double-insulated type or grounded in accordance with Electrical Requirements.
2. The use of electric cords for hoisting or lowering tools shall not be permitted.

PNEUMATIC POWER TOOLS

1. Pneumatic power tools shall be secured to the hose or whip by some positive means to prevent the tool from becoming accidentally disconnected.
2. Safety clips or retainers shall be securely installed and maintained on pneumatic impact (percussion) tools to prevent attachments from being accidentally expelled.
3. All pneumatically driven nailers, staplers, and other similar equipment provided with automatic fastener feed, which operate at more than 100 psi pressure at the tool shall have a safety device on the muzzle to prevent the tool from ejecting fasteners, unless the muzzle is in contact with the work surface.
4. Compressed air shall not be used for cleaning purposes except where reduced to less than 30 psi and then only with effective chip guarding and personal protective equipment which meets the requirements of Subpart E of this part. The 30 psi requirement does not apply for concrete form, mill scale and similar cleaning purposes.
5. The manufacturer's safe operating pressure for hoses, pipes, valves, filters, and other fittings shall not be exceeded.
6. The use of hoses for hoisting or lowering tools shall not be permitted.
7. All hoses exceeding 1/2-inch inside diameter shall have a safety device at the source of supply or branch line to reduce pressure in case of hose failure.
8. Airless spray guns of the type which atomize paints and fluids at high pressures (1,000 pounds or more per square inch) shall be equipped with automatic or visible manual safety devices which will prevent pulling of the trigger to prevent release of the paint or fluid until the safety device is manually released.
9. In lieu of the above, a diffuser nut which will prevent high pressure, high velocity release, while the nozzle tip is removed, plus a nozzle tip guard which will prevent the tip from coming into contact with the operator, or other equivalent protection, shall be provided.
10. "Abrasive blast cleaning nozzles" The blast cleaning nozzles shall be equipped with an operating valve which must be held open manually. A support shall be provided on which the nozzle may be mounted when it is not in use.

FUEL POWERED TOOLS

1. All fuel powered tools shall be stopped while being refueled, serviced, or maintained, and fuel shall be transported, handled, and stored in accordance with Subpart F of this part.
2. When fuel powered tools are used in enclosed spaces, the applicable requirements for concentrations of toxic gases and use of personal protective equipment, as outlined in Subparts D and E of this part, shall apply.

HYDRAULIC POWER TOOLS

1. The fluid used in hydraulic powered tools shall be fire-resistant fluids approved under Schedule 30 of the U.S. Bureau of Mines, Department of the Interior, and shall retain its operating characteristics at the most extreme temperatures to which it will be exposed.
2. The manufacturer's safe operating pressures for hoses, valves, pipes, filters, and other fittings shall not be exceeded.

POWDER-ACTUATED TOOLS

1. Only employees who have been trained in the operation of the particular tool in use shall be allowed to operate a powder-actuated tool and employees having a certificate of fitness, issued by NYCFD E21 using power activated materials.
2. The tool shall be tested each day before loading to see that safety devices are in proper working condition. The method of testing shall be in accordance with the manufacturer's recommended procedure.
3. Any tool found not in proper working order, or that develops a defect during use, shall be immediately removed from service and not used until properly repaired.
4. Personal protective equipment shall be in accordance with Subpart E of this part.
5. Tools shall not be loaded until just prior to the intended firing time. Neither loaded nor empty tools are to be pointed at any employees. Hands shall be kept clear of the open barrel end.
6. Loaded tools shall not be left unattended.
7. Fasteners shall not be driven into very hard or brittle materials including, but not limited to, cast iron, glazed tile, surface-hardened steel, glass block, live rock, face brick, or hollow tile.
8. Driving into materials easily penetrated shall be avoided unless such materials are backed by a substance that will prevent the pin or fastener from passing completely through and creating a flying missile hazard on the other side.
9. No fastener shall be driven into a spalled area caused by an unsatisfactory fastening.
10. Tools shall not be used in an explosive or flammable atmosphere.
11. All tools shall be used with the correct shield, guard, or attachment recommended by the manufacturer.
12. Powder-actuated tools used by employees shall meet all other applicable requirements of American National Standards Institute, A10.3-1970, Safety Requirements for Explosive-Actuated Fastening Tools.

ABRASIVE WHEELS AND POWER TOOLS

All grinding machines shall be supplied with sufficient power to maintain the spindle speed at safe levels under all conditions of normal operation.

Guarding

1. Grinding machines shall be equipped with safety guards in conformance with the requirements of American National Standards Institute, B7.1-1970, Safety Code for the Use, Care and Protection of Abrasive Wheels, and paragraph (d) of this section.

2. "Guarding design." The safety guard shall cover the spindle end, nut, and flange projections. The safety guard shall be mounted so as to maintain proper alignment with the wheel, and the strength of the fastenings shall exceed the strength of the guard, except:
3. Safety guards on all operations where the work provides a suitable measure of protection to the operator, may be so constructed that the spindle end, nut, and outer flange are exposed; and where the nature of the work is such as to entirely cover the side of the wheel, the side covers of the guard may be omitted; and
4. The spindle end, nut, and outer flange may be exposed on machines designed as portable saws.

Use of Abrasive Wheels

1. Floor stand and bench mounted abrasive wheels, used for external grinding, shall be provided with safety guards (protection hoods). The maximum angular exposure of the grinding wheel periphery and sides shall be not more than 90 deg, except that when work requires contact with the wheel below the horizontal plane of the spindle, the angular exposure shall not exceed 125 deg. In either case, the exposure shall begin not more than 65 deg. above the horizontal plane of the spindle. Safety guards shall be strong enough to withstand the effect of a bursting wheel.
2. Floor and bench-mounted grinders shall be provided with work rests which are rigidly supported and readily adjustable. Such work rests shall be kept at a distance not to exceed one-eighth inch from the surface of the wheel.
3. Cup type wheels used for external grinding shall be protected by either a revolving cup guard or a band type guard in accordance with the provisions of the American National Standards Institute, B7.1-1970 Safety Code for the Use, Care, and Protection of Abrasive Wheels. All other portable abrasive wheels used for external grinding, shall be provided with safety guards (protection hoods) meeting the requirements of #5, except as follows:
 - a. When the work location makes it impossible, a wheel equipped with safety flanges, as described in #6 of this section, shall be used
 - b. When wheels 2 inches or less in diameter which are securely mounted on the end of a steel mandrel are used.
4. Portable abrasive wheels used for internal grinding shall be provided with safety flanges (protection flanges) meeting the requirements in #6 of this section, except as follows:
 - a. When wheels 2 inches or less in diameter which are securely mounted on the end of a steel mandrel are used;
 - b. If the wheel is entirely within the work being ground while in use.
5. When safety guards are required, they shall be so mounted as to maintain proper alignment with the wheel, and the guard and its fastenings shall be of sufficient strength to retain fragments of the wheel in case of accidental breakage. The maximum angular exposure of the grinding wheel periphery and sides shall not exceed 180 deg.
6. When safety flanges are required, they shall be used only with wheels designed to fit the flanges. Only safety flanges, of a type and design and properly assembled so as to ensure that the pieces of the wheel will be retained in case of accidental breakage, shall be used.
7. All abrasive wheels shall be closely inspected and ring-tested before mounting to ensure that they are free from cracks or defects.
8. Grinding wheels shall fit freely on the spindle and shall not be forced on. The spindle nut shall be tightened only enough to hold the wheel in place.
9. All employees using abrasive wheels shall be protected by eye protection equipment in accordance with the requirements of Subpart E of this part, except when adequate eye protection is afforded by eye shields which are permanently attached to the bench or floor stand.

OTHER REQUIREMENTS

1. All abrasive wheels and tools used by employees shall meet other applicable requirements of American National Standards Institute, B7.1-1970 and Safety Code for the Use, Care and Protection of Abrasive Wheels.
2. "Work rests." On offhand grinding machines, work rests shall be used to support the work. They shall be of rigid construction and designed to be adjustable to compensate for wheel wear. Work rests shall be kept adjusted closely to the wheel with a maximum opening of 1/8 inch (0.3175 cm) to prevent the work from being jammed between the wheel and the rest, which may cause wheel breakage. The work rest shall be securely clamped after each adjustment. The adjustment shall not be made with the wheel in motion.

WOODWORKING TOOLS

1. Disconnect switches. All fixed power driven woodworking tools shall be provided with a disconnect switch that can either be locked or tagged in the off position.
2. Speeds. The operating speed shall be etched or otherwise permanently marked on all circular saws over 20 inches in diameter or operating at over 10,000 peripheral feet per minute. Any saw so marked shall not be operated at a speed other than that marked on the blade. When a marked saw is re-tensioned for a different speed, the marking shall be corrected to show the new speed.
3. Self-feed. Automatic feeding devices shall be installed on machines whenever the nature of the work will permit. Feeder attachments shall have the feed rolls or other moving parts covered or guarded so as to protect the operator from hazardous points.
4. Guarding. All portable, power-driven circular saws shall be equipped with guards above and below the base plate or shoe. The upper guard shall cover the saw to the depth of the teeth, except for the minimum arc required to permit the base to be tilted for bevel cuts. The lower guard shall cover the saw to the depth of the teeth, except for the minimum arc required to allow proper retraction and contact with the work. When the tool is withdrawn from the work, the lower guard shall automatically and instantly return to the covering position.
5. Personal protective equipment. All personal protective equipment provided for use shall conform to Subpart E of this part.
6. Other requirements. All woodworking tools and machinery shall meet other applicable requirements of American National Standards Institute, 01.1-1961, Safety Code for Woodworking Machinery.

RADIAL SAWS

The upper hood shall completely enclose the upper portion of the blade down to a point that will include the end of the saw arbor. The upper hood shall be constructed in such a manner and of such material that it will protect the operator from flying splinters, broken saw teeth, etc., and will deflect sawdust away from the operator. The sides of the lower exposed portion of the blade shall be guarded to the full diameter of the blade by a device that will automatically adjust itself to the thickness of the stock and remain in contact with stock being cut to give maximum protection possible for the operation being performed.

JACKS – LEVER AND RATCHET, SCREW, AND HYDRAULIC

General Requirements

1. The manufacturer's rated capacity shall be legibly marked on all jacks and shall not be exceeded.
2. All jacks shall have a positive stop to prevent over travel.
3. Blocking. When it is necessary to provide a firm foundation, the base of the jack shall be blocked or cribbed. Where there is a possibility of slippage of the metal cap of the jack, a wood block shall be placed between the cap and the load.

Operation and Maintenance

1. After the load has been raised, it shall be cribbed, blocked, or otherwise secured at once.
2. Hydraulic jacks exposed to freezing temperatures shall be supplied with an adequate antifreeze liquid.
3. All jacks shall be properly lubricated at regular intervals.
4. Each jack shall be thoroughly inspected at times which depend upon the service conditions. Inspections shall be not less frequent than the following:
 5. For constant or intermittent use at one locality, once every 6 months,
 6. For jacks sent out of shop for special work, when sent out and when returned,
 7. For a jack subjected to abnormal load or shock, immediately before and immediately thereafter.
 8. Repair or replacement parts shall be examined for possible defects.
 9. Jacks which are out of order shall be tagged accordingly, and shall not be used until repairs are made.

AIR RECEIVERS

General Requirements

Application

This section applies to compressed air receivers, and other equipment used in providing and utilizing compressed air for performing operations such as cleaning, drilling, hoisting, and chipping. On the other hand, however, this section does not deal with the special problems created by using compressed air to convey materials nor the problems created when men work in compressed air as in tunnels and caissons. This section is not intended to apply to compressed air machinery and equipment used on transportation vehicles such as steam railroad cars, electric railway cars, and automotive equipment.

New and Existing Equipment

1. All new air receivers installed after the effective date of these regulations shall be constructed in accordance with the 1968 edition of the A.S.M.E. Boiler and Pressure Vessel Code Section VIII.
2. All safety valves used shall be constructed, installed and maintained in accordance with the A.S.M.E. Boiler and Pressure Vessel Code, Section VIII Edition 1968.

Installation and Equipment Requirements

Installation

Air receivers shall be so installed that all drains, handholds, and manholes therein are easily accessible. Under no circumstances shall an air receiver be buried underground or located in an inaccessible place.

Drains and Traps

A drainpipe and valve shall be installed at the lowest point of every air receiver to provide for the removal of accumulated oil and water. Adequate automatic traps may be installed in addition to drain valves. The drain valve on the air receiver shall be opened and the receiver completely drained frequently and at such intervals as to prevent the accumulation of excessive amounts of liquid in the receiver.

Gages and Valves

1. Every air receiver shall be equipped with an indicating pressure gage (so located as to be readily visible) and with one or more spring-loaded safety valves. The total relieving capacity of such safety valves shall be such as to prevent pressure in the receiver from exceeding the maximum allowable working pressure of the receiver by more than 10 percent.
2. No valve of any type shall be placed between the air receiver and its safety valve or valves.
3. Gages and valves – continued
4. Safety appliances, such as safety valves, indicating devices and controlling devices, shall be constructed, located, and installed so that they cannot be readily rendered inoperative by any means, including the elements.
5. All safety valves shall be tested frequently and at regular intervals to determine whether they are in good operating condition.

Part 12: Materials Handling, Storage, Use and Disposal

INTRODUCTION

On School Construction Authority Projects where Materials Handling, Storage, Use and Disposal is to take place Federal OSHA Standards, current New York City Department of Building Codes and School Construction Authority Safety Program & Procedures Manual and any other governing agencies laws, regulations, procedures shall be adhered to. The most stringent of these standards shall be applicable.

General Requirement for Storage

1. All materials stored in tiers shall be stacked, racked, blocked, interlocked, or otherwise secured to prevent sliding, falling or collapse.
2. Maximum safe load limits of floors within buildings and structures, in pounds per square foot, shall be conspicuously posted in all storage areas, except for floor or slab on grade. Maximum safe loads shall not be exceeded.
3. Aisles and passageways shall be kept clear to provide for the free and safe movement of material handling equipment or employees. Such areas shall be kept in good repair.
4. When a difference in road or working levels exist, means such as ramps, blocking, or grading shall be used to ensure the safe movement of vehicles between the two levels.

Material Storage

1. Material stored inside buildings under construction shall not be placed within 6 feet of any hoistway or inside floor openings, nor within 10 feet of an exterior wall which does not extend above the top of the material stored.
2. Each employee required to work on stored material in silos, hoppers, tanks, and similar storage areas shall be equipped with personal fall arrest equipment meeting the requirements of Fall Protection of this Safety Manual.
3. Noncompatible materials shall be segregated in storage.
 - a. Bagged materials shall be stacked by stepping back the layers and cross-keying the bags at least every 10 bags high.
4. Materials shall not be stored on scaffolds or runways in excess of supplies needed for immediate operations.

5. Brick stacks shall not be more than 7 feet in height. When a loose brick stack reaches a height of 4 feet, it shall be tapered back 2 inches in every foot of height above the 4-foot level.
6. When masonry blocks are stacked higher than 6 feet, the stack shall be tapered back one-half block per tier above the 6-foot level.
7. On occupied schools materials and equipment shall not be stored outside of a secure staging area (as per the approved Site Safety Plan) or in any area that is accessible to the public.

Lumber

1. Used lumber shall have all nails withdrawn before stacking.
2. Lumber shall be stacked on level and solidly supported sills.
3. Lumber shall be so stacked as to be stable and self-supporting.
4. Lumber piles shall not exceed 20 feet in height provided that lumber to be handled manually shall not be stacked more than 16 feet high.

Cylindrical Materials

Structural steel, poles, pipe, bar stock, and other cylindrical materials, unless racked, shall be stacked and blocked so as to prevent spreading or tilting.

Housekeeping

Storage areas shall be kept free from accumulation of materials that constitute hazards from tripping, fire, explosion, or pest harborage. Vegetation control will be exercised when necessary.

Dockboards (bridge plates)

1. Portable and powered dockboards shall be strong enough to carry the load imposed on them.
2. Portable dockboards shall be secured in position, either by being anchored or equipped with devices which will prevent their slipping.
3. Handholds, or other effective means, shall be provided on portable dockboards to permit safe handling.
4. Positive protection shall be provided to prevent railroad cars from being moved while dockboards or bridge plates are in position.

Rigging Equipment for Material Handling

General

1. Rigging equipment for material handling shall be inspected prior to use on each shift and as necessary during its use to ensure that it is safe. Defective rigging equipment shall be removed from service.
2. Rigging equipment shall not be loaded in excess of its recommended safe working load, as prescribed in Tables H-1 through H-20 in this subpart.
3. Rigging equipment, when not in use, shall be removed from the immediate work area so as not to present a hazard to employees.
4. Special custom design grabs, hooks, clamps, or other lifting accessories, for such units as modular panels, prefabricated structures and similar materials, shall be marked to indicate the safe working loads and shall be proof-tested prior to use to 125 percent of their rated load.
5. Scope. This section applies to slings used in conjunction with other material handling equipment for the movement of material by hoisting, in employments covered by this part. The types of slings covered are those made from alloy steel chain, wire rope, metal mesh, natural or synthetic

fiber rope (conventional three strand construction), and synthetic web (nylon, polyester, and polypropylene).

6. Inspections. Each day before being used, the sling and all fastenings and attachments shall be inspected for damage or defects by a competent person designated by the employer. Additional inspections shall be performed during sling use, where service conditions warrant. Damaged or defective slings shall be immediately removed from service.

Wire rope

1. Tables H-3 through H-14 shall be used to determine the safe working loads of various sizes and classifications of improved plow steel wire rope and wire rope slings with various types of terminals. For sizes, classifications, and grades not included in these tables, the safe working load recommended by the manufacturer for specific, identifiable products shall be followed, provided that a safety factor of not less than 5 is maintained.
2. Protruding ends of strands in splices on slings and bridles shall be covered or blunted.
3. Wire rope shall not be secured by knots, except on haul back lines on scrapers.
4. The following limitations shall apply to the use of wire rope:
 - a. An eye splice made in any wire rope shall have not less than three full tucks. However, this requirement shall not operate to preclude the use of another form of splice or connection which can be shown to be as efficient and which is not otherwise prohibited.
 - b. Except for eye splices in the ends of wires and for endless rope slings, each wire rope used in hoisting or lowering, or in pulling loads, shall consist of one continuous piece without knot or splice.
 - c. Eyes in wire rope bridles, slings, or bull wires shall not be formed by wire rope clips or knots.
 - d. Wire rope shall not be used if, in any length of eight diameters, the total number of visible broken wires exceeds 10 percent of the total number of wires, or if the rope shows other signs of excessive wear, corrosion, or defect.
5. When U-bolt wire rope clips are used to form eyes, Table H-20 shall be used to determine the number and spacing of clips.
 - a. When used for eye splices, the U-bolt shall be applied so that the "U" section is in contact with the dead end of the rope.
6. Slings shall not be shortened with knots or bolts or other makeshift devices.
7. Sling legs shall not be kinked.
8. Slings used in a basket hitch shall have the loads balanced to prevent slippage.
9. Slings shall be padded or protected from the sharp edges of their loads.
10. Hands or fingers shall not be placed between the sling and its load while the sling is being tightened around the load.
11. Shock loading is prohibited.
12. A sling shall not be pulled from under a load when the load is resting on the sling.
13. Minimum sling lengths;
 - a. Cable laid and 6 X 19 and 6 X 37 slings shall have minimum clear length of wire rope 10 times the component rope diameter between splices, sleeves or end fittings.
 - b. Braided slings shall have a minimum clear length of wire rope 40 times the component rope diameter between the loops or end fittings.
 - c. Cable laid grommets, strand laid grommets and endless slings shall have a minimum circumferential length of 96 times their body diameter.
14. Safe operating temperatures." Fiber core wire rope slings of all grades shall be permanently removed from service if they are exposed to temperatures in excess of 200 deg. F (93.33 deg. C). When nonfiber core wire rope slings of any grade are used at temperatures above 400 deg. F (204.44 deg. C) or below minus 60 deg. F (15.55 deg. C), recommendations of the sling manufacturer regarding use at that temperature shall be followed.
15. End attachments.
 - a. Welding of end attachments, except covers to thimbles, shall be performed prior to the assembly of the sling.

- b. All welded end attachments shall not be used unless proof tested by the manufacturer or equivalent entity at twice their rated capacity prior to initial use. The employer shall retain a certificate of proof test, and make it available for examination.

Natural Rope and Synthetic Fiber

General

1. When using natural or synthetic fiber rope slings, Tables H-15, 16, 17, and 18 shall apply.
2. All splices in rope slings provided by the employer shall be made in accordance with fiber rope manufacturers recommendations.
 - a. In manila rope, eye splices shall contain at least three full tucks, and short splices shall contain at least six full tucks (three on each side of the center line of the splice).
 - b. In layed synthetic fiber rope, eye splices shall contain at least four full tucks, and short splices shall contain at least eight full tucks (four on each side of the center line of the splice).
 - c. Strand end tails shall not be trimmed short (flush with the surface of the rope) immediately adjacent to the full tucks. This precaution applies to both eye and short splices and all types of fiber rope. For fiber ropes under 1-inch diameter, the tails shall project at least six rope diameters beyond the last full tuck. For fiber ropes 1-inch diameter and larger, the tails shall project at least 6 inches beyond the last full tuck. In applications where the projecting tails may be objectionable, the tails shall be tapered and spliced into the body of the rope using at least two additional tucks (which will require a tail length of approximately six rope diameters beyond the last full tuck).
 - d. For all eye splices, the eye shall be sufficiently large to provide an included angle of not greater than 60 deg. at the splice when the eye is placed over the load or support.
 - e. Knots shall not be used in lieu of splices.
3. Safe operating temperatures. Natural and synthetic fiber rope slings, except for wet frozen slings, may be used in a temperature range from minus 20 deg. F (-28.88 deg. C) to plus 180 deg. F (82.2 deg. C) without decreasing the working load limit. For operations outside this temperature range and for wet frozen slings, the sling manufacturer's recommendations shall be followed.
4. Splicing. Spliced fiber rope slings shall not be used unless they have been spliced in accordance with the following minimum requirements and in accordance with any additional recommendations of the manufacturer:
 - a. In manila rope, eye splices shall consist of at least three full tucks, and short splices shall consist of at least six full tucks, three on each side of the splice center line.
 - b. In synthetic fiber rope, eye splices shall consist of at least four full tucks, and short splices shall consist of at least eight full tucks, four on each side of the center line.
 - c. Strand end tails shall not be trimmed flush with the surface of the rope immediately adjacent to the full tucks. This applies to all types of fiber rope and both eye and short splices. For fiber rope under 1 inch (2.54 cm) in diameter, the tail shall project at least six rope diameters beyond the last full tuck. For fiber rope 1 inch (2.54 cm) in diameter and larger, the tail shall project at least 6 inches (15.24 cm) beyond the last full tuck. Where a projecting tail interferes with the use of the sling, the tail shall be tapered and spliced into the body of the rope using at least two additional tucks (which will require a tail length of approximately six rope diameters beyond the last full tuck).
 - d. Fiber rope slings shall have a minimum clear length of rope between eye splices equal to 10 times the rope diameter.
 - e. Knots shall not be used in lieu of splices.
 - f. Clamps not designed specifically for fiber ropes shall not be used for splicing.
 - g. For all eye splices, the eye shall be of such size to provide an included angle of not greater than 60 degrees at the splice when the eye is placed over the load or support.

5. End attachments. Fiber rope slings shall not be used if end attachments in contact with the rope have sharp edges or projections.
6. Removal from service. Natural and synthetic fiber rope slings shall be immediately removed from service if any of the following conditions are present:
 - a. Abnormal wear.
 - b. Powdered fiber between strands.
 - c. Broken or cut fibers.
 - d. Variations in the size or roundness of strands.
 - e. Discoloration or rotting.
 - f. Distortion of hardware in the sling.

Synthetic Webbing (nylon, polyester, and polypropylene)

1. The employer shall have each synthetic web sling marked or coded to show:
 - a. Name or trademark of manufacturer.
 - b. Rated capacities for the type of hitch.
 - c. Type of material.
2. Rated capacity shall not be exceeded.
3. Webbing. Synthetic webbing shall be of uniform thickness and width and selvage edges shall not be split from the webbing's width.
4. Fittings. Fittings shall be:
 - a. Of a minimum breaking strength equal to that of the sling; and
 - b. Free of all sharp edges that could in any way damage the webbing.
5. Attachment of end fittings to webbing and formation of eyes. Stitching shall be the only method used to attach end fittings to webbing and to form eyes. The thread shall be in an even pattern and contain a sufficient number of stitches to develop the full breaking strength of the sling.
6. Environmental conditions. When synthetic web slings are used, the following precautions shall be taken:
 - a. Nylon web slings shall not be used where fumes, vapors, sprays, mists or liquids of acids or phenolics are present.
 - b. Polyester and polypropylene web slings shall not be used where fumes, vapors, sprays, mists or liquids of caustics are present.
 - c. Web slings with aluminum fittings shall not be used where fumes, vapors, sprays, mists or liquids of caustics are present.
7. Safe operating temperatures. Synthetic web slings of polyester and nylon shall not be used at temperatures in excess of 180 deg. F (82.2 deg. C). Polypropylene web slings shall not be used at temperatures in excess of 200 deg. F (93.33 deg. C).
8. Removal from service. Synthetic web slings shall be immediately removed from service if any of the following conditions are present:
 - a. Acid or caustic burns;
 - b. Melting or charring of any part of the sling surface;
 - c. Snags, punctures, tears or cuts;
 - d. Broken or worn stitches; or
 - e. Distortion of fittings.

Shackles and Hooks.

1. Table H-19 shall be used to determine the safe working loads of various sizes of shackles, except that higher safe working loads are permissible when recommended by the manufacturer for specific, identifiable products, provided that a safety factor of not less than 5 is maintained.

2. The manufacturer's recommendations shall be followed in determining the safe working loads of the various sizes and types of specific and identifiable hooks. All hooks for which no applicable manufacturer's recommendations are available shall be tested to twice the intended safe working load before they are initially put into use. The employer shall maintain a record of the dates and results of such tests.

Disposal of Waste Materials

1. An enclosed chute of wood, or equivalent material, shall be used whenever materials are dropped below any point lying outside the exterior walls of a building. For the purpose of this paragraph, an enclosed chute is a slide, closed in on all sides, through which material is moved from a high place to a lower one.
2. When debris is dropped through holes in the floor without the use of chutes, the area onto which the material is dropped shall be completely enclosed with barricades not less than 42 inches high and not less than 6 feet back from the projected edge of the opening above. Signs warning of the hazard of falling materials shall be posted at each level. Removal shall not be permitted in this lower area until debris handling ceases above.
3. All scrap lumber, waste material, and rubbish shall be removed from the immediate work area as the work progresses.
4. Disposal of waste material or debris by burning shall comply with local fire regulations.
5. All solvent waste, oily rags, and flammable liquids shall be kept in fire resistant covered containers until removed from worksite.

RATED CAPACITY TABLES

**TABLE H-1
RATED CAPACITY (WORKING LOAD LIMIT),
FOR ALLOY STEEL CHAIN SLINGS¹**

Rated Capacity (Working Load Limit), Pounds [Horizontal angles shown in parentheses]³

Chain size, inches	Single branch sling-- 90° loading	Double sling vertical angle ²			Triple and quadruple sling vertical angle ²		
		30° (60°)	45° (45°)	60° (30°)	30° (60°)	45° (45°)	60° (30°)
1/4	3,250	5,560	4,550	3,250	8,400	6,800	4,900
3/8	6,600	11,400	9,300	6,600	17,000	14,000	9,900
1/2	11,250	19,500	15,900	11,250	29,000	24,000	17,000
5/8	16,500	28,500	23,300	16,500	43,000	35,000	24,500
3/4	23,000	39,800	32,500	23,000	59,500	48,500	34,500
7/8	28,750	49,800	40,600	28,750	74,500	61,000	43,000
1	38,750	67,100	54,800	38,750	101,000	82,000	58,000
1 1/8	44,500	77,000	63,000	44,500	115,500	94,500	66,500
1 1/4	57,500	99,500	81,000	57,500	149,000	121,500	86,000
1 3/8	67,000	116,000	94,000	67,000	174,000	141,000	100,500
1 1/2	80,000	138,000	112,900	80,000	207,000	169,000	119,500
1 3/4	100,000	172,000	140,000	100,000	258,000	210,000	150,000

¹ Other grades of proof tested steel chain include Proof Coil, BBB Coil and Hi-Test Chain. These grades are not recommended for overhead lifting and therefore are not covered by this code.

² Rating of multileg slings adjusted for angle of loading measured as the included angle between the inclined leg and the vertical.

³ Rating of multileg slings adjusted for angle of loading between the inclined leg and the horizontal plane of the load.

**TABLE H-2
MAXIMUM ALLOWABLE WEAR AT ANY POINT OF LINK**

Chain size, inches	Max. allowable wear (inch)
1/4	3/64
3/8	5/64
1/2	7/64
5/8	9/64
3/4	5/32
7/8	11/64
1	3/16
1 1/8	7/32
1 1/4	1/4
1 3/8	9/32
1 1/2	5/16
1 3/4	11/32

TABLE H-3
RATED CAPACITIES FOR SINGLE LEG SLINGS
 6x19 and 6x37 Classification Improved Plow Steel Grade Rope With Fiber Core (FC)

Rope		Rated capacities, tons (2,000 lb)								
Dia (inches)	Con-str.	Vertical			Choker			Vertical Basket ¹		
		HT	MS	S	HT	MS	S	HT	MS	S
1/4	6x19	0.49	0.51	0.55	0.37	0.38	0.41	0.99	1.0	1.1
5/16	6x19	0.76	0.79	0.85	0.57	0.59	0.64	1.5	1.6	1.7
3/8	6x19	1.1	1.1	1.2	0.80	0.85	0.91	2.1	2.2	2.4
7/16	6x19	1.4	1.5	1.6	1.1	1.1	1.2	2.9	3.0	3.3
1/2	6x19	1.8	2.0	2.1	1.4	1.5	1.6	3.7	3.9	4.3
9/16	6x19	2.3	2.5	2.7	1.7	1.9	2.0	4.6	5.0	5.4
5/8	6x19	2.8	3.1	3.3	2.1	2.3	2.5	5.6	6.2	6.7
3/4	6x19	3.9	4.4	4.8	2.9	3.3	3.6	7.8	8.8	9.5
7/8	6x19	5.1	5.9	6.4	3.9	4.5	4.8	10.0	12.0	13.0
1	6x19	6.7	7.7	8.4	5.0	5.8	6.3	13.0	15.0	17.0
1 1/8	6x19	8.4	9.5	10.0	6.3	7.1	7.9	17.0	19.0	21.0
1 1/4	6x37	9.8	11.0	12.0	7.4	8.3	9.2	20.0	22.0	25.0
1 3/8	6x37	12.0	13.0	15.0	8.9	10.0	11.0	24.0	27.0	30.0
1 1/2	6x37	14.0	16.0	17.0	10.0	12.0	13.0	28.0	32.0	35.0
1 5/8	6x37	16.0	18.0	21.0	12.0	14.0	15.0	33.0	27.0	41.0
1 3/4	6x37	19.0	21.0	24.0	14.0	16.0	18.0	38.0	43.0	48.0
2	6x37	25.0	28.0	31.0	18.0	21.0	23.0	49.0	55.0	62.0

¹ These values only apply when the D/d ratio for HT slings is 10 or greater, and for MS and S Slings is 20 or greater where:

D = Diameter of curvature around which the body of the sling is bent; d = Diameter of rope;

HT = Hand Tucked Splice and Hidden Tuck Splice. For hidden tuck splice (IWRC) use values in HT columns;

MS = Mechanical Splice;

S= Swaged or Zinc Poured Socket.

TABLE H-4. - RATED CAPACITIES FOR SINGLE LEG SLINGS

6x19 and 6x37 Classification Improved Plow Steel Grade Rope With Independent Wire Rope Core (IWRC)

Rope		Rated capacities, tons (2,000 lb)								
Dia (inches)	Constr.	Vertical			Choker			Vertical Basket ¹		
		HT	MS	S	HT	MS	S	HT	MS	S
1/4	6x19	0.53	0.56	0.59	0.40	0.42	0.44	1.0	1.1	1.2
5/16	6x19	0.81	0.87	0.92	0.61	0.65	0.69	1.6	1.7	1.8
3/8	6x19	1.1	1.2	1.3	0.86	0.93	0.98	2.3	2.5	2.6
7/16	6x19	1.5	1.7	1.8	1.2	1.3	1.3	3.1	3.4	3.5
1/2	6x19	2.0	2.2	2.3	1.5	1.6	1.7	3.9	4.4	4.6
9/16	6x19	2.5	2.7	2.9	1.8	2.1	2.2	4.9	5.5	5.8
5/8	6x19	3.0	3.4	3.6	2.2	2.5	2.7	6.0	6.8	7.2
3/4	6x19	4.2	4.9	5.1	3.1	3.6	3.8	8.4	9.7	10.0
7/8	6x19	5.5	6.6	6.9	4.1	4.9	5.2	11.0	13.0	14.0
1	6x19	7.2	8.5	9.0	5.4	6.4	6.7	14.0	17.0	18.0
1 1/8	6x19	9.0	10.0	11.0	6.8	7.8	8.5	18.0	21.0	23.0
1 1/4	6x37	10.0	12.0	13.0	7.9	9.2	9.9	21.0	24.0	26.0
1 3/8	6x37	13.0	15.0	16.0	9.6	11.0	12.0	25.0	29.0	32.0
1 1/2	6x37	15.0	17.0	19.0	11.0	13.0	14.0	30.0	35.0	38.0
1 5/8	6x37	18.0	20.0	22.0	13.0	15.0	17.0	35.0	41.0	44.0
1 3/4	6x37	20.0	24.0	26.0	15.0	18.0	19.0	41.0	47.0	51.0
2	6x37	26.0	30.0	33.0	20.0	23.0	25.0	53.0	61.0	66.0

¹ These values only apply when the D/d ratio for HT slings is 10 or greater, and for MS and S slings is 20 or greater where: D = Diameter of curvature around which the body of the sling is bent; d= Diameter of rope;

HT= Hand Tucked Splice. For hidden tuck splice (IWRC) use Table H-3 values in HT column; MS = Mechanical Splice; S = Swaged or Zinc Poured Socket.

TABLE H-5. - RATED CAPACITIES FOR SINGLE LEG SLINGS

Cable Laid Rope -- Mechanical Splice Only,
 7x7x7 & 7X7X19 Constructions Galvanized Aircraft Grade Rope
 7x6x19 IWRC Construction Improved Plow Steel Grade Rope

Rope		Rated capacities, tons (2,000 lb.)		
Dia (inches)	Constr	Vertical	Choker	Vertical basket ¹
1/4	7x7x7	0.50	0.38	1.0
3/8	7x7x7	1.1	0.81	2.2
1/2	7x7x7	1.8	1.4	3.7
5/8	7x7x7	2.8	2.1	5.5
3/4	7x7x7	3.8	2.9	7.6
5/8	7x7x19	2.9	2.2	5.8
3/4	7x7x19	4.1	3.0	8.1
7/8	7x7x19	5.4	4.0	11.0
1	7x7x19	6.9	5.1	14.0
1 1/8	7x7x19	8.2	6.2	16.0
1 1/4	7x7x19	9.9	7.4	20.0
3/4	² 7x6x19	3.8	2.8	7.6
7/8	² 7x6x19	5.0	3.8	10.0
1	² 7x6x19	6.4	4.8	13.0
1 1/8	² 7x6x19	7.7	5.8	15.0
1 1/4	² 7x6x19	9.2	6.9	18.0
1 5/16	² 7x6x19	10.0	7.5	20.0
1 3/8	² 7x6x19	11.0	8.2	22.0
1 1/2	² 7x6x19	13.0	9.6	26.0

¹ These values only apply when the D/d ratio is 10 or greater where:

D = Diameter of curvature around which the body of the sling is bent;

d = Diameter of rope.

² IWRC

TABLE H-6. - RATED CAPACITIES FOR SINGLE LEG SLINGS

8-Part and 6-Part Braided Rope, 6x7 and 6x19 Construction Improved
 Plow Steel Grade Rope, 7x7 Construction Galvanized Aircraft Grade Rope

Component Rope		Rated capacities, tons (2,000 lb)					
Dia (inches)	Constr.	Vertical		Choker		Basket vertical to 30° ¹	
		8-Part	6-Part	8-Part	6-Part	8-Part	6-Part
3/32	6x7	0.42	0.32	0.32	0.24	0.74	0.55
1/8	6x7	0.76	0.57	0.57	0.42	1.3	0.98
3/16	6x7	1.7	1.3	1.3	0.94	2.9	2.2
3/32	7x7	0.51	0.39	0.39	0.29	0.89	0.67
1/8	7x7	0.95	0.71	0.71	0.53	1.6	1.2
3/16	7x7	2.1	1.5	1.5	1.2	3.6	2.7
3/16	6x19	1.7	1.3	1.3	0.98	3.0	2.2
1/4	6x19	3.1	2.3	2.3	1.7	5.3	4.0
5/16	6x19	4.8	3.6	3.6	2.7	8.3	6.2
3/8	6x19	6.8	5.1	5.1	3.8	12.0	8.9
7/16	6x19	9.3	6.9	6.9	5.2	16.0	12.0
1/2	6x19	12.0	9.0	9.0	6.7	21.0	15.0
9/16	6x19	15.0	11.0	11.0	8.5	26.0	20.0
5/8	6x19	19.0	14.0	14.0	10.0	32.0	24.0
3/4	6x19	27.0	20.0	20.0	15.0	46.0	35.0
7/8	6x19	36.0	27.0	27.0	20.0	62.0	47.0
1	6x19	47.0	35.0	35.0	26.0	81.0	61.0

¹ These values only apply when the D/d ratio is 20 or greater where: D = Diameter of curvature around which the body of the sling is bent; d = Diameter of component rope.

TABLE H-7. - RATED CAPACITIES FOR 2-LEG AND 3-LEG BRIDLE SLINGS

6x19 and 6x37 Classification Improved Plow Steel Grade Rope With Fiber Core (FC)

Rope		Rated capacities, tons (2,000 lb)											
Dia (in-ches)	Con-str.	2-Leg bridle slings						3-Leg bridle slings					
		30° ¹ (60°) ²		45° angle		60° ¹ (30°) ²		30° ¹ (60°) ²		45° angle		60° ¹ (30°) ²	
		HT	MS	HT	MS	HT	MS	HT	MS	HT	MS	HT	MS
1/4	6x19	0.85	0.88	0.70	0.72	0.49	0.51	1.3	1.3	1.0	1.1	0.74	0.76
5/16	6x19	1.3	1.4	1.1	1.1	0.76	0.79	2.0	2.0	1.6	1.7	1.1	1.2
3/8	6x19	1.8	1.9	1.5	1.6	1.1	1.1	2.8	2.9	2.3	2.4	1.6	1.7
7/16	6x19	2.5	2.6	2.0	2.2	1.4	1.5	3.7	4.0	3.0	3.2	2.1	2.3
1/2	6x19	3.2	3.4	2.6	2.8	1.8	2.0	4.8	5.1	3.9	4.2	2.8	3.0
9/16	6x19	4.0	4.3	3.2	3.5	2.3	2.5	6.0	6.5	4.9	5.3	3.4	3.7
5/8	6x19	4.8	5.3	4.0	4.4	2.8	3.1	7.3	8.0	5.9	6.5	4.2	4.6
3/4	6x19	6.8	7.6	5.5	6.2	3.9	4.4	10.0	11.0	8.3	9.3	5.8	6.6
7/8	6x19	8.9	10.0	7.3	8.4	5.1	5.9	13.0	15.0	11.0	13.0	7.7	8.9
1	6x19	11.0	13.0	9.4	11.0	6.7	7.7	17.0	20.0	14.0	16.0	10.0	11.0
1 1/8	6x19	14.0	16.0	12.0	13.0	8.4	9.5	22.0	24.0	18.0	20.0	13.0	14.0
1 1/4	6x37	17.0	19.0	14.0	16.0	9.8	11.0	25.0	29.0	21.0	23.0	15.0	17.0
1 3/8	6x37	20.0	23.0	17.0	19.0	12.0	13.0	31.0	35.0	25.0	28.0	18.0	20.0
1 1/2	6x37	24.0	27.0	20.0	22.0	14.0	16.0	36.0	41.0	30.0	33.0	21.0	24.0
1 5/8	6x37	28.0	32.0	23.0	26.0	16.0	18.0	43.0	48.0	35.0	39.0	25.0	28.0
1 3/4	6x37	33.0	37.0	27.0	30.0	19.0	21.0	49.0	56.0	40.0	45.0	28.0	32.0
2	6x37	43.0	48.0	35.0	39.0	25.0	28.0	64.0	72.0	52.0	59.0	37.0	41.0

¹ Vertical angles. ² Horizontal angles. HT = Hand Tucked Splice. MS = Mechanical Splice.

TABLE H-8. - RATED CAPACITIES FOR 2-LEG AND 3-LEG BRIDLE SLINGS

6x19 and 6x37 Classification Improved Plow Steel Grade Rope With Independent Wire Rope Core (IWRC)

Rope		Rated capacities, tons (2,000 lb)											
Dia (in-ches)	Con-str.	2-Leg bridle slings						3-Leg bridle slings					
		30° ¹ (60°) ²		45° angle		60° ¹ (30°) ²		30° ¹ (60°) ²		45° angle		60° ¹ (30°) ²	
		HT	MS	HT	MS	HT	MS	HT	MS	HT	MS	HT	MS
1/4	6x19	0.92	0.97	0.75	0.79	0.53	0.56	1.4	1.4	1.1	1.2	0.79	0.84
5/16	6x19	1.4	1.5	1.1	1.2	0.81	0.87	2.1	2.3	1.7	1.8	1.2	1.3
3/8	6x19	2.0	2.1	1.6	1.8	1.1	1.2	3.0	3.2	2.4	2.6	1.7	1.9
7/16	6x19	2.7	2.9	2.2	2.4	1.5	1.7	4.0	4.4	3.3	3.6	2.3	2.5
1/2	6x19	3.4	3.8	2.8	3.1	2.0	2.2	5.1	5.7	4.2	4.6	3.0	3.3
9/16	6x19	4.3	4.8	3.5	3.9	2.5	2.7	6.4	7.1	5.2	5.8	3.7	4.1
5/8	6x19	5.2	5.9	4.2	4.8	3.0	3.4	7.8	8.8	6.4	7.2	4.5	5.1
3/4	6x19	7.3	8.4	5.9	6.9	4.2	4.9	11.0	13.0	8.9	10.0	6.3	7.3
7/8	6x19	9.6	11.0	7.8	9.3	5.5	6.6	14.0	17.0	12.0	14.0	8.3	9.9
1	6x19	12.0	15.0	10.0	12.0	7.2	8.5	19.0	22.0	15.0	18.0	11.0	13.0
1 1/8	6x19	16.0	18.0	13.0	15.0	9.0	10.0	23.0	27.0	19.0	22.0	13.0	16.0
1 1/4	6x37	18.0	21.0	15.0	17.0	10.0	12.0	27.0	32.0	22.0	26.0	16.0	18.0
1 3/8	6x37	22.0	25.0	18.0	21.0	13.0	15.0	33.0	38.0	27.0	31.0	19.0	22.0
1 1/2	6x37	26.0	30.0	21.0	25.0	15.0	17.0	39.0	45.0	32.0	37.0	23.0	26.0
1 5/8	6x37	31.0	35.0	25.0	29.0	18.0	20.0	46.0	53.0	38.0	43.0	27.0	31.0
1 3/4	6x37	35.0	41.0	29.0	33.0	20.0	24.0	53.0	61.0	43.0	50.0	31.0	35.0
2	6x37	46.0	53.0	37.0	43.0	26.0	30.0	68.0	79.0	56.0	65.0	40.0	46.0

¹ Vertical angles. ² Horizontal angles. HT = Hand Tucked Splice. MS = Mechanical Splice.

TABLE H-9. - RATED CAPACITIES FOR 2-LEG AND 3-LEG BRIDLE SLINGS

Cable Laid Rope - Mechanical Splice Only, 7x7x7 and 7x7x19 Construction
Galvanized Aircraft Grade Rope, 7x6x19 IWRC Construction Improved Plow Steel Grade Rope

Rope		Rated capacities, tons (2,000 lb)					
Dia (in-ches)	Constr.	2-Leg bridle slings			3-Leg bridle slings		
		30° ¹ (60°) ²	45° angle	60° ¹ (30°) ²	30° ¹ (60°) ²	45° angle	60° ¹ (30°) ²
1/4	7x7x7	0.87	0.71	0.50	1.3	1.1	0.75
3/8	7x7x7	1.9	1.5	1.1	2.8	2.3	1.6
1/2	7x7x7	3.2	2.6	1.8	4.8	3.9	2.8
5/8	7x7x7	4.8	3.9	2.8	7.2	5.9	4.2
3/4	7x7x7	6.6	5.4	3.8	9.9	8.1	5.7
5/8	7x7x19	5.0	4.1	2.9	7.5	6.1	4.3
3/4	7x7x19	7.0	5.7	4.1	10.0	8.6	6.1
7/8	7x7x19	9.3	7.6	5.4	14.0	11.0	8.1
1	7x7x19	12.0	9.7	6.9	18.0	14.0	10.0
1 1/8	7x7x19	14.0	12.0	8.2	21.0	17.0	12.0
1 1/4	7x7x19	17.0	14.0	9.9	26.0	21.0	15.0
3/4	7x6x19 IWRC	6.6	5.4	3.8	9.9	8.0	5.7
7/8	7x6x19 IWRC	8.7	7.1	5.0	13.0	11.0	7.5
1	7x6x19 IWRC	11.0	9.0	6.4	17.0	13.0	9.6
1 1/8	7x6x19 IWRC	13.0	11.0	7.7	20.0	16.0	11.0
1 1/4	7x6x19 IWRC	16.0	13.0	9.2	24.0	20.0	14.0
1 5/16	7x6x19 IWRC	17.0	14.0	10.0	26.0	21.0	15.0
1 3/8	7x6x19 IWRC	19.0	15.0	11.0	28.0	23.0	16.0
1 1/2	7x6x19 IWRC	22.0	18.0	13.0	33.0	27.0	19.0

¹ Vertical angles. ² Horizontal angles.

TABLE H-10. - RATED CAPACITIES FOR 2-LE AND 3-LEG BRIDLE SLINGS

8-Part and 6-Part Braided Rope, 6x7 and 6x19 Construction Improved
 Plow Steel Grade Rope, 7x7 Construction Galvanized Aircraft Grade Rope

Rope		Rated capacities, tons (2,000 lb)											
Dia (in-ches)	Con-str.	2-Leg bridle slings						3-Leg bridle slings					
		30° ¹ (60°) ²		45° angle		60° ¹ (30°) ²		30° ¹ (60°) ²		45° angle		60° ¹ (30°) ²	
		8 -Part	6 -Part	8 -Part	6 -Part	8 -Part	6 -part	8 -Part	6 -Part	8 -Part	6 -Part	8 -Part	6 -part
3/32	6x7	0.74	0.55	0.60	0.45	0.42	0.32	1.1	0.83	0.90	0.68	0.64	0.48
1/8	6x7	1.3	0.98	1.1	0.80	0.76	0.57	2.0	1.5	1.6	1.2	1.1	0.85
3/16	6x7	2.9	2.2	2.4	1.8	1.7	1.3	4.4	3.3	3.6	2.7	2.5	1.9
3/32	7x7	0.89	0.67	0.72	0.55	0.51	0.39	1.3	1.0	1.1	0.82	0.77	0.58
1/8	7x7	1.6	1.2	1.3	1.0	0.95	0.71	2.5	1.8	2.0	1.5	1.4	1.1
3/16	7x7	3.6	2.7	2.9	2.2	2.1	1.5	5.4	4.0	4.4	3.3	3.1	2.3
3/16	6x19	3.0	2.2	2.4	1.8	1.7	1.3	4.5	3.4	3.7	2.8	2.6	1.9
1/4	6x19	5.3	4.0	4.3	3.2	3.1	2.3	8.0	6.0	6.5	4.9	4.6	3.4
5/16	6x19	8.3	6.2	6.7	5.0	4.8	3.6	12.0	9.3	10.0	7.6	7.1	5.4
3/8	6x19	12.0	8.9	9.7	7.2	6.8	5.1	18.0	13.0	14.0	11.0	10.0	7.7
7/16	6x19	16.0	12.0	13.0	9.8	9.3	6.9	24.0	18.0	20.0	15.0	14.0	10.0
1/2	6x19	21.0	15.0	17.0	13.0	12.0	9.0	31.0	23.0	25.0	19.0	18.0	13.0
9/16	6x19	26.0	20.0	21.0	16.0	15.0	11.0	39.0	29.0	32.0	24.0	23.0	17.0
5/8	6x19	32.0	24.0	26.0	20.0	19.0	14.0	48.0	36.0	40.0	30.0	28.0	21.0
3/4	6x19	46.0	35.0	38.0	28.0	27.0	20.0	69.0	52.0	56.0	42.0	40.0	30.0
7/8	6x19	62.0	47.0	51.0	38.0	36.0	27.0	94.0	70.0	76.0	57.0	54.0	40.0
1	6x19	81.0	61.0	66.0	50.0	47.0	35.0	122.0	91.0	99.0	74.0	70.0	53.0

¹ Vertical angles. ² Horizontal angles.

**TABLE H-11.
RATED CAPACITIES
FOR STRAND LAID GROMMET -- HAND TUCKED**

Improved Plow Steel Grade Rope

Rope Body		Rated capacities, tons (2,000 lb.)		
Dia (inches)	Constr	Vertical	Choker	Vertical basket ¹
1/4	7x19	0.85	0.64	1.7
5/16	7x19	1.3	1.0	2.6
3/8	7x19	1.9	1.4	3.8
7/16	7x19	2.6	1.9	5.2
1/2	7x19	3.3	2.5	6.7
9/16	7x19	4.2	3.1	8.4
5/8	7x19	5.2	3.9	10.0
3/4	7x19	7.4	5.6	15.0
7/8	7x19	10.0	7.5	20.0
1	7x19	13.0	9.7	26.0
1 1/8	7x19	16.0	12.0	32.0
1 1/4	7x37	18.0	14.0	37.0
1 3/8	7x37	22.0	16.0	44.0
1 1/2	7x37	26.0	19.0	52.0

¹ These values only apply when the D/d ratio is 5 or greater where:

D=Diameter of curvature around which rope is bent.

d=Diameter of rope body.

TABLE H-12
RATED CAPACITIES
FOR CABLE LAID GROMMET - HAND TUCKED
 7x6x7 and 7x6x19 Constructions Improved Plow Steel Grade Rope
 7x7x7 Construction Galvanized Aircraft Grade Rope

Rope Body		Rated capacities, tons (2,000 lb.)		
Dia (inches)	Constr.	Vertical	Choker	Vertical basket ¹
3/8	7x6x7	1.3	0.95	2.5
9/16	7x6x7	2.8	2.1	5.6
5/8	7x6x7	3.8	2.8	7.6
3/8	7x7x7	1.6	1.2	3.2
9/16	7x7x7	3.5	2.6	6.9
5/8	7x7x7	4.5	3.4	9.0
5/8	7x6x19	3.9	3.0	7.9
3/4	7x6x19	5.1	3.8	10.0
15/16	7x6x19	7.9	5.9	16.0
1 1/8	7x6x19	11.0	8.4	22.0
1 5/16	7x6x19	15.0	11.0	30.0
1 1/2	7x6x19	19.0	14.0	39.0
1 11/16	7x6x19	24.0	18.0	49.0
1 7/8	7x6x19	30.0	22.0	60.0
2 1/4	7x6x19	42.0	31.0	84.0
2 5/8	7x6x19	56.0	42.0	112.0

¹ These values only apply when the D/d ratio is 5 or greater where: D = Diameter of curvature around which cable body is bent,

d = Diameter of cable body.

TABLE H-13
RATED CAPACITIES FOR STRAND LAID ENDLESS
SLINGS -- MECHANICAL JOINT

Improved Plow Steel Grade Rope

Rope Body		Rated capacities, tons (2,000 lb.)		
Dia (inches)	Constr.	Vertical	Choker	Vertical basket ¹
1/4	² 6x19	0.92	0.69	1.8
3/8	² 6x19	2.0	1.5	4.1
1/2	² 6x19	3.6	2.7	7.2
5/8	² 6x19	5.6	4.2	11.0
3/4	² 6x19	8.0	6.0	16.0
7/8	² 6x19	11.0	8.1	21.0
1	² 6x19	14.0	10.0	28.0
1 1/8	² 6x19	18.0	13.0	35.0
1 1/4	² 6x37	21.0	15.0	41.0
1 3/8	² 6x37	25.0	19.0	50.0
1 1/2	² 6x37	29.0	22.0	59.0

¹ These values only apply when the D/d ratio is 5 or greater where: D=Diameter of curvature around which rope is bent, d=Diameter of rope body.

² IWRC.

TABLE H-14
RATED CAPACITIES FOR
CABLE LAID ENDLESS SLINGS -- MECHANICAL JOINT

7x7x7 and 7x7x19 Constructions Galvanized Aircraft Grade Rope
 7x6x19 Construction Improved Plow Steel Grade Rope

Cable Body		Rated capacities, tons (2,000 lb.)		
Dia (inches)	Constr	Vertical	Choker	Vertical basket (1)
1/4	7x7x7	0.83	0.62	1.6
3/8	7x7x7	1.8	1.3	3.5
1/2	7x7x7	3.0	2.3	6.1
5/8	7x7x7	4.5	3.4	9.1
3/4	7x7x7	6.3	4.7	12.0
5/8	7x7x19	4.7	3.5	9.5
3/4	7x7x19	6.7	5.0	13.0
7/8	7x7x19	8.9	6.6	18.0
1	7x7x19	11.0	8.5	22.0
1 1/8	7x7x19	14.0	10.0	28.0
1 1/4	7x7x19	17.0	12.0	33.0
3/4	² 7x6x19	6.2	4.7	12.0
7/8	² 7x6x19	8.3	6.2	16.0
1	² 7x6x19	10.0	7.9	21.0
1 1/8	² 7x6x19	13.0	9.7	26.0
1 1/4	² 7x6x19	16.0	12.0	31.0
1 3/8	² 7x6x19	18.0	14.0	37.0
1 1/2	² 7x6x19	22.0	16.0	43.0

¹ These values only apply when the D/d value is 5 or greater where: D=Diameter of curvature around which cable body is bent.
 d=Diameter of cable body.

² IWRC.

TABLE H-15. -- MANILA ROPE SLINGS

[Angle of rope to vertical shown in parentheses]

Rope dia. nominal in inches	Nominal weight per 100 ft in pounds	Minimum breaking strength in pounds	Rated capacity in pounds (safety factor=5)											
			Eye and eye sling						Endless sling					
			Vertical hitch	Choker hitch	Basket hitch; Angel of rope to horizontal				Vertical hitch	Choker hitch	Basket hitch; Angel of rope to horizontal			
					90° (0°)	60° (30°)	45° (45°)	30° (60°)			90° (0°)	60° (30°)	45° (45°)	30° (60°)
1/2	7.5	2,650	550	250	1,100	900	750	550	950	500	1,900	1,700	1,400	950
9/16	10.4	3,450	700	350	1,400	1,200	1,000	700	1,200	600	2,500	2,200	1,800	1,200
5/8	13.3	4,400	900	450	1,800	1,500	1,200	900	1,600	800	3,200	2,700	2,200	1,600
3/4	16.7	5,400	1,100	550	2,200	1,900	1,500	1,100	2,000	950	3,900	3,400	2,800	2,000
13/16	19.5	6,500	1,300	650	2,600	2,300	1,800	1,300	2,300	1,200	4,700	4,100	3,300	2,300
7/8	22.5	7,700	1,500	750	3,100	2,700	2,200	1,500	2,800	1,400	5,600	4,800	3,900	2,800
1	27.0	9,000	1,800	900	3,600	3,100	2,600	1,800	3,200	1,600	6,500	5,600	4,600	3,200
1 1/16	31.3	10,500	2,100	1,100	4,200	3,600	3,000	2,100	3,800	1,900	7,600	6,600	5,400	3,800
1 1/8	36.0	12,000	2,400	1,200	4,800	4,200	3,400	2,400	4,300	2,200	8,600	7,500	6,100	4,300
1 1/4	41.7	13,500	2,700	1,400	5,400	4,700	3,800	2,700	4,900	2,400	9,700	8,400	6,900	4,900
1 5/16	47.9	15,000	3,000	1,500	6,000	5,200	4,300	3,000	5,400	2,700	11,000	9,400	7,700	5,400
1 1/2	59.9	18,500	3,700	1,850	7,400	6,400	5,200	3,700	6,700	3,300	13,500	11,500	9,400	6,700
1 5/8	74.6	22,500	4,500	2,300	9,000	7,800	6,400	4,500	8,100	4,100	16,000	14,000	11,500	8,000
1 3/4	89.3	26,500	5,300	2,700	10,500	9,260	7,500	5,300	9,500	4,800	19,000	16,500	13,500	9,590
2	107.5	31,000	6,200	3,100	12,500	10,500	8,800	6,200	11,000	5,600	22,500	19,500	16,000	11,000
2 1/3	125.0	36,000	7,200	3,600	14,500	12,500	10,000	7,200	13,000	6,500	26,000	22,500	18,500	13,000
2 1/4	146.0	41,000	8,200	4,100	16,500	14,000	11,500	8,200	15,000	7,400	29,500	25,500	21,000	15,000
2 1/2	166.7	46,500	9,300	4,700	18,500	16,000	13,000	9,300	16,500	8,400	33,500	29,000	23,500	16,500
2 5/8	190.8	52,000	10,500	5,200	21,000	18,000	14,500	10,500	18,500	9,500	37,500	32,500	26,500	18,500

TABLE H-16. -- NYLON ROPE SLINGS
 [Angle of rope to vertical shown in parentheses]

Rope dia. nominal in inches	Nominal weight per 100 ft in pounds	Minimum breaking strength in pounds	Rated capacity in pounds (safety factor=9)											
			Eye and eye sling						Endless sling					
			Vertical hitch	Choker hitch	Basket hitch; Angel of rope to horizontal				Vertical hitch	Choker hitch	Basket hitch; Angel of rope to horizontal			
					90° (0°)	60° (30°)	45° (45°)	30° (60°)			90° (0°)	60° (30°)	45° (45°)	30° (60°)
1/2	6.5	6,080	700	350	1,400	1,200	950	700	1,200	600	2,400	2,100	1,700	1,200
9/16	8.3	7,600	850	400	1,700	1,500	1,200	850	1,500	750	3,000	2,600	2,200	1,500
5/8	10.5	9,880	1,100	550	2,200	1,900	1,600	1,100	2,000	1,100	4,000	3,400	2,800	2,000
3/4	14.5	13,490	1,500	750	3,000	2,600	2,100	1,500	2,700	1,400	5,400	4,700	3,800	2,700
13/16	17.0	16,150	1,800	900	3,600	3,100	2,600	1,800	3,200	1,600	6,400	5,600	4,600	3,200
7/8	20.0	19,000	2,100	1,100	4,200	3,700	3,000	2,100	3,800	1,900	7,600	6,600	5,400	3,800
1	26.0	23,750	2,600	1,300	5,300	4,600	3,700	2,600	4,800	2,400	9,500	8,200	6,700	4,800
1 1/16	29.0	27,360	3,000	1,500	6,100	5,300	4,300	3,000	5,500	2,700	11,000	9,500	7,700	5,500
1 1/8	34.0	31,350	3,500	1,700	7,000	6,000	5,000	3,500	6,300	3,100	12,500	11,000	8,900	6,300
1 1/4	40.0	35,625	4,000	2,000	7,900	6,900	5,600	4,000	7,100	3,600	14,500	12,500	10,000	7,100
1 5/16	45.0	40,850	4,500	2,300	9,100	7,900	6,400	4,500	8,200	4,100	16,500	14,000	12,000	8,200
1 1/2	55.0	50,350	5,600	2,800	11,000	9,700	7,900	5,600	10,000	5,000	20,000	17,500	14,000	10,000
1 5/8	68.0	61,750	6,900	3,400	13,500	12,000	9,700	6,900	12,500	6,200	24,500	21,500	17,500	12,500
1 3/4	83.0	74,100	8,200	4,100	16,500	14,500	11,500	8,200	15,000	7,400	29,500	27,500	21,000	15,000
2	95.0	87,400	9,700	4,900	19,500	17,000	13,500	9,700	17,500	8,700	35,000	30,500	24,500	17,500
2 1/8	109.0	100,700	11,000	5,600	22,500	19,500	16,000	11,000	20,000	10,000	40,500	35,000	28,500	20,000
2 1/4	129.0	118,750	13,000	6,600	26,500	23,000	18,500	13,000	24,000	12,000	47,500	41,000	33,500	24,000
2 1/2	149.0	133,000	15,000	7,400	29,500	25,500	21,000	15,000	26,500	13,500	53,000	46,000	37,500	26,500
2 5/8	168.0	153,900	17,100	8,600	34,000	29,500	24,000	17,000	31,000	15,500	61,500	53,500	43,500	31,000

TABLE H-17. -- POLYESTER ROPE SLINGS

[Angle of rope to vertical shown in parentheses]

Rope dia. nominal in inches	Nominal weight per 100 ft in pounds	Minimum breaking strength in pounds	Rated capacity in pounds (safety factor=9)											
			Eye and eye sling						Endless sling					
			Vertical hitch	Choker hitch	Basket hitch; Angel of rope to horizontal				Vertical hitch	Choker hitch	Basket hitch; Angel of rope to horizontal			
					90° (0°)	60° (30°)	45° (45°)	30° (60°)			90° (0°)	60° (30°)	45° (45°)	30° (60°)
1/2	8.0	6,080	700	350	1,400	1,200	950	700	1,200	600	2,400	2,100	1,700	1,200
9/16	10.2	7,600	850	400	1,700	1,500	1,200	850	1,500	750	3,000	2,600	2,200	1,500
5/8	13.0	9,500	1,100	550	2,100	1,800	1,500	1,100	1,900	950	3,800	3,300	2,700	1,900
3/4	17.5	11,875	1,300	650	2,600	2,300	1,900	1,300	2,400	1,200	4,800	4,100	3,400	2,400
13/16	21.0	14,725	1,600	800	3,300	2,800	2,300	1,600	2,900	1,500	5,900	5,100	4,200	2,900
7/8	25.0	17,100	1,900	950	3,800	3,300	2,700	1,900	3,400	1,700	6,800	5,900	4,800	3,400
1	30.5	20,900	2,300	1,200	4,600	4,000	3,300	2,300	4,200	2,100	8,400	7,200	5,900	4,200
1 1/16	34.5	24,225	2,700	1,300	5,400	4,700	3,800	2,700	4,800	2,400	9,700	8,400	6,900	4,800
1 1/8	40.0	28,025	3,100	1,600	6,200	5,400	4,400	3,100	5,600	2,800	11,000	9,700	7,900	5,600
1 1/4	46.3	31,540	3,500	1,800	7,000	6,100	5,000	3,500	6,300	3,200	12,500	11,000	8,900	6,300
1 5/16	52.5	35,625	4,000	2,000	7,900	6,900	5,600	4,000	7,100	3,600	14,500	12,500	10,000	7,100
1 1/2	66.8	44,460	4,900	2,500	9,900	8,600	7,000	4,900	8,900	4,400	18,000	15,500	12,500	8,900
1 5/8	82.0	54,150	6,000	3,000	12,000	10,400	8,500	6,000	11,000	5,500	21,500	19,000	15,500	11,000
1 3/4	98.0	64,410	7,200	3,600	14,500	12,500	10,000	7,200	13,000	6,400	26,000	22,500	18,000	13,000
2	118.0	76,000	8,400	4,200	17,000	14,500	12,000	8,400	15,000	7,600	30,500	26,500	21,500	15,000
2 1/8	135.0	87,400	9,700	4,900	19,500	17,000	13,500	9,700	17,500	8,700	35,000	30,500	24,500	17,500
2 1/4	157.0	101,650	11,500	5,700	22,500	19,500	16,000	11,500	20,500	10,000	40,500	35,000	29,000	20,500
2 1/2	181.0	115,900	13,000	6,400	26,000	22,500	18,000	13,000	23,000	11,500	46,500	40,000	33,000	23,000
2 5/8	205.0	130,150	14,500	7,200	29,000	25,000	20,500	14,500	26,000	13,000	52,000	45,000	37,000	26,000

TABLE H-18. -- POLYPROPYLENE ROPE SLINGS

[Angle of rope to vertical shown in parentheses]

Rope dia. nominal in inches	Nominal weight per 100 ft in pounds	Minimum breaking strength in pounds	Rated capacity in pounds (safety factor=6)											
			Eye and eye sling						Endless sling					
			Vertical hitch	Choker hitch	Basket hitch; Angel of rope to horizontal				Vertical hitch	Choker hitch	Basket hitch; Angel of rope to horizontal			
					90° (0°)	60° (30°)	45° (45°)	30° (60°)			90° (0°)	60° (30°)	45° (45°)	30° (60°)
1/2	4.7	3,990	650	350	1,300	1,200	950	650	1,200	600	2,400	2,100	1,700	1,200
9/16	6.1	4,845	800	400	1,600	1,400	1,100	800	1,500	750	2,900	2,500	2,100	1,500
5/8	7.5	5,890	1,000	500	2,000	1,700	1,400	1,000	1,800	900	3,500	3,100	2,500	1,800
3/4	10.7	8,075	1,300	700	2,700	2,300	1,900	1,300	2,400	1,200	4,900	4,200	3,400	2,400
13/16	12.7	9,405	1,600	800	3,100	2,700	2,200	1,600	2,800	1,400	5,600	4,900	4,000	2,800
7/8	15.0	10,925	1,800	900	3,600	3,200	2,600	1,800	3,300	1,600	6,600	5,700	4,600	3,300
1	18.0	13,300	2,200	1,100	4,400	3,800	3,100	2,200	4,000	2,000	8,000	6,900	5,600	4,000
1/16	20.4	15,200	2,500	1,300	5,100	4,400	3,600	2,500	4,600	2,300	9,100	7,900	6,500	4,600
1 1/8	23.7	17,385	2,900	1,500	5,800	5,000	4,100	2,900	5,200	2,600	10,500	9,000	7,400	5,200
1 1/4	27.0	19,950	3,300	1,700	6,700	5,800	4,700	3,300	6,000	3,000	12,000	10,500	8,500	6,000
1 5/16	30.5	22,325	3,700	1,900	7,400	6,400	5,300	3,700	6,700	3,400	13,500	11,500	9,500	6,700
1 1/2	38.5	28,215	4,700	2,400	9,400	8,100	6,700	4,700	8,500	4,200	17,000	14,500	12,000	8,500
1 5/8	47.5	34,200	5,700	2,900	11,500	9,900	8,100	5,700	10,500	5,100	20,500	18,000	14,500	10,500
1 3/4	57.0	40,850	6,800	3,400	13,500	12,000	9,600	6,800	12,500	6,100	24,500	21,000	17,500	12,500
2	69.0	49,400	8,200	4,100	16,500	14,500	11,500	8,200	15,000	7,400	29,500	25,500	21,000	15,000
2 1/8	80.0	57,950	9,700	4,800	19,500	16,500	13,500	9,700	17,500	8,700	35,000	30,100	24,500	17,500
2 1/4	92.0	65,550	11,000	5,500	22,000	19,000	15,500	11,000	19,500	9,900	39,500	34,000	28,000	19,500
2 1/2	107.0	76,000	12,500	6,300	25,500	22,000	18,000	12,500	23,000	11,500	45,500	39,500	32,500	23,000
2 5/8	120.0	85,500	14,500	7,100	28,500	24,500	20,000	14,500	25,500	13,000	51,500	44,500	36,500	25,500

TABLE H-19. - Safe Working Loads for Shackles

(In tons of 2,000 pounds)

Material size (inches)	Pin diameter (inches)	Safe working load
1/2	5/8	1.4
5/8	3/4	2.2
3/4	7/8	3.2
7/8	1	4.3
1	1 1/8	5.6
1 1/8	1 1/4	6.7
1 1/4	1 3/8	8.2
1 3/8	1 1/2	10.0
1 1/2	1 5/8	11.9
1 3/4	2	16.2
2	2 1/4	21.2

TABLE H-20. - Number and Spacing of U-bolt Wire Rope Clips

Improved plow steel, rope diameter (inches)	Number of clips		Minimum spacing (inches)
	Drop forged	Other material	
1/2	3	4	3
5/8	3	4	3 3/4
3/4	4	5	4 1/2
7/8	4	5	5 1/4
1	5	6	6
1 1/8	6	6	6 3/4
1 1/4	6	7	7 1/2
1 3/8	7	7	8 1/4
1 1/2	7	8	9

Part 13: Personal Protective Equipment

INTRODUCTION

On School Construction Authority Projects where Personal Protective Equipment is required to be used the Federal OSHA Standards, current New York City Department of Building Codes and School Construction Safety Program & Procedures Manual and any other governing agencies laws, regulations and procedures shall be implemented. The most stringent of these standards shall be applicable.

BASIC TERMINOLOGY

Definitions for the following terms are listed alphabetically within the Glossary located at the back of this publication:

- Contaminant
- Lanyard
- Lifeline
- Optical Density
- Radiant Energy
- Safety Belt



SCA GENERAL REQUIREMENTS

1. On all SCA projects the minimum Personal Protective Equipment to be worn is work boots, hard hats, long pants and shirts with sleeves to cover the shoulders.
2. On all *occupied schools* contractor's employees shall be required to wear a photo I.D. on their person at all times while on site.
3. No short pants, shorts, sneakers, sleeveless shirts are permitted to be worn on construction sites.

PERSONAL PROTECTIVE EQUIPMENT

Protective equipment, including personal protective equipment for eyes, face, head, and extremities, protective clothing, respiratory devices, and protective shields and barriers, shall be provided, used, and maintained in a sanitary and reliable condition wherever it is necessary by reason of hazards of processes or environment, chemical hazards, radiological hazards, or mechanical irritants encountered in a manner capable of causing injury or impairment in the function of any part of the body through absorption, inhalation or physical contact.

Employee Owned Equipment

Where employees provide their own protective equipment, the employer shall be responsible to assure its adequacy, including proper maintenance, and sanitation of such equipment.

Design

All personal protective equipment shall be of safe design and construction for the work to be performed.

Occupational Foot Protection

Safety toe footwear for employees shall meet the requirements and specification in American national Standard for Men's Safety Toe Footwear, Z41.1-1967.

Head Protection

1. All employees working on SCA Projects are to wear protective helmets (hardhats) at all times. See attachment relating to Safety Requirements and Requests for Religious Accommodation.
2. Helmets for the protection of employees against impact and penetration of falling and flying objects shall meet the specifications contained in American National Standards Institute, Z89.1-1969, Safety Requirements for Industrial Head Protection.
3. Helmets for the head protection of employees exposed to high voltage electrical shock and burns shall meet the specifications contained in American national Standards Institute, Z89.2-1971.

Hearing Protection

1. Wherever it is not feasible to reduce the noise levels or duration of exposures to those specified in Table 16: Permissible Noise Exposures below, ear protective devices shall be provided and used.

Permissible Noise Exposures	
Duration (per day, hours)	Sound Level (dBA slow response)
8	90
6	92
4	95
3	97
2	100
1 ½	102
1	105
½	110
¼	115

Table 16: Permissible Noise Exposures

2. Protection against the effect of noise exposure shall be provided when the sound levels exceed those shown in Table 16 when measured on the A-scale of a standard sound level meter at slow response.
3. When employees are subjected to sound levels exceeding those listed in Table 16, feasible administrative or engineering controls shall be utilized. If such controls fail to reduce sound levels within the levels of the table, personal protective equipment as required in this section, shall be provided and used to reduce sound levels within the levels of the table.
4. If the variations in noise level involve maxima at intervals of 1 second or less, it is to be considered continuous.

5. In all cases where the sound levels exceed the values shown herein, a continuing, effective hearing conservation program shall be administered.
6. When the daily noise exposure is composed of two or more periods of noise exposure of different levels, their combined effect should be considered, rather than the individual effect of each. Exposure to different levels for various periods of time shall be computed.
7. Ear protective devices inserted in the ear shall be fitted or determined individually by competent persons.
8. Plain cotton is not an acceptable protective device.

Eye and Face Protection

1. Employees shall be provided with eye and face protection equipment when machines or operations present potential eye or face injury from physical, chemical, or radiation agents.
2. Eye and face protection equipment required by this Part shall meet the requirements specified in American National Standards Institute, Z87.1-1968, Practice for occupational and Educational Eye and Face Protection.
3. Employees whose vision requires the use of corrective lenses in spectacles, when required by this regulation to wear eye protection, shall be protected by goggles or spectacles of one of the following types:
 - a. Spectacles whose protective lenses provide optical correction
 - b. Goggles that can be worn over corrective spectacles without disturbing the adjustment of the spectacles
 - c. Goggles that incorporate corrective lenses mounted behind the protect lenses
4. Face and eye protection equipment shall be kept clean and in good repair. The use of this type equipment with structural or optical defects shall be prohibited.
5. Table E-1 shall be used as a guide in the selection of face and eye protection for the hazards and operations noted.
6. Protectors shall meet the following minimum requirements;
 - a. They shall provide adequate protection against the particular hazards for which they are designed
 - b. They shall be reasonable comfortable when worn under the designated conditions
 - c. They shall fit snugly and shall not unduly interfere with the movements of the wearer
 - d. They shall be durable
 - e. They shall be capable of being disinfected
 - f. They shall be easily cleanable
7. Every protection shall be distinctly marked to facilitate identification only of the manufacturer.
8. When limitations or precautions are indicated by the manufacturer, they shall be transmitted to the user and care taken to see that such limitations and precautions are strictly observed.

Protection Against Radiant Energy

Selection of shade numbers for welding filter Table 17: Filter Lens for Protection below shall be used as a guide for the selection of the proper shade numbers of filter lenses or plates used in welding. Shades more dense than those listed may be used to suit the individual's needs.

Filter Lens Shade Numbers for Protection Against Radiant Energy	
Welding operation	Shade number
Shielded metal-arc welding 1/16, 3/32, 1/8, 5/32 inch diameter electrodes	10
Gas shielded arc welding (nonferrous) 1/16, 3/32, 1/8, 5/32 inch diameter electrodes	11
Gas shielded arc welding (ferrous) 1/16, 3/32, 1/8, 5/32 inch diameter electrodes	12
Shielded metal arc welding 3/16, 7/32, 1/4 inch Diameter electrodes	12
5/16, 3/8 inch diameter electrodes	14
Atomic hydrogen welding	10-14
Carbon arc welding	14
Soldering	2
Torch Brazing	3 or 4
Light Cutting, up to 1 inch	3 or 4
Medium cutting, 1 inch to 6 inches	4 or 5
Heavy cutting, over 6 inches	5 or 6
Gas welding (light) up to 1/8 inch	4 or 5
Gas welding (medium) 1/8 inch to 1/2 inch	5 or 6
Gas welding (heavy) over 1/2 inch	6 or 8

Table 17: Filter Lens for Protection

Laser Protection

1. Employees whose occupation or assignment requires exposure to laser beams shall be furnished suitable laser safety goggles, which will protect for the specific wavelength of the laser and be of optical density (OD) adequate for the energy involved. Table 18: Laser Safety Glass below lists the maximum power or energy density for which adequate protection is afforded by glasses of optical densities from 5 through 8.

Selecting Laser Safety Glass		
Intensity CW	Optical Density	Attenuation Factor
Maximum Power Density (watts/cm²)		
10 -2	5	10 to the 5 th power
10 -1	6	10 to the 6 th power
1.0	7	10 to the 7 th power
10.	8	10 to the 8 th power

*Output levels falling between lines in this table shall require the higher optical density.

Table 18: Laser Safety Glass

2. All protective goggles shall bear a label identifying the following data.
 - a. The laser wavelengths for which use is intended
 - b. The optical density of those wavelengths
 - c. The visible light transmission

Respiratory Protection

The employer shall be responsible for providing current-training records, fit test records and a properly administrated, written respiratory protection program.

SAFETY BELTS, LIFELINES, AND LANYARDS

1. Lifelines, safety belts, and lanyards shall be used only for employee safeguarding. Any lifeline, safety belt, or lanyard actually subjected to in-service loading, as distinguished from static load testing, shall be immediately removed from service and shall not be used again for employee safeguarding.
2. Lifelines shall be secured above the point of operation to an anchorage or structural member capable of supporting a minimum dead weight of 5,400 pounds.
3. Lifelines used on rock scaling operations, or in areas where the lifeline may be subjected to cutting or abrasion, shall be a minimum of 7/8 inch wire core manila rope. For all other lifeline applications, a minimum of 3/4 inch manila or equivalent, with a minimum breaking strength of 5,400 pounds, shall be used.
4. Safety belt lanyard shall be a minimum of 1/2 inch nylon, or equivalent, with a maximum length to provide for a fall of no greater than 6 feet. The rope shall have a nominal breaking strength of 5,400 pounds.
5. All safety belt and lanyard hardware shall be drop forged or pressed steel, cadmium plated in accordance with type 1, Class B plating specified in Federal Specification QQ-P-416. Surface shall be smooth and free of sharp edges.
6. All safety belt and lanyard hardware, except rivet, shall be capable of withstanding a tensile loading of 4,000 pounds without cracking, breaking, or taking a permanent deformation.

SAFETY NETS

1. Safety nets shall be provided when workplaces are more than 25 feet above the ground or water surface or other surfaces where the use of ladders, scaffolds, catch platforms, temporary floors, safety lines, or safety belts is impractical.
2. Where safety net protection is required by this section, operations shall not be undertaken until the net is in place and has been tested.
3. Nets shall extend 8 feet beyond the edge of the work surface where employees are exposed and shall be installed as close under the work surface as practical but in no case more than 25 feet below such work surface. Nets shall be hung with sufficient clearance to prevent user's contact with the surfaces or structures below. Such clearances shall be determined by impact load testing.
4. It is intended that only one level of nets be required for bridge construction.
5. The mesh size of nets shall not exceed 6 inches by 6 inches. All new nets shall meet accepted performance standards of 17,500 foot pounds minimum impact resistance as determined and certified by the manufacturers, and shall bear a label of proof test. Edge ropes shall provide a minimum breaking strength of 5,000 pounds.
6. Forged steel safety hooks or shackles shall be used to fasten the net to its supports
3. Connections between net panels shall develop the full strength of the net.

Part 14: Public Protection

INTRODUCTION

On School Construction Authority Projects where a Sidewalk Bridge or Fencing is required, Federal OSHA standards, current New York City Department of Building Codes and School Construction Authority Safety Program & Procedures Manual and any other governing agencies laws, regulations, and procedures shall be implemented. The most stringent of these standards shall be applicable.

SIDEWALK SHEDS

Sidewalk sheds shall be erected on School Construction Authority Projects such as specified in the Approved Site Safety Plan, and shall be filed with NYC D.O.B.



SCA GENERAL REQUIREMENTS

Sidewalk Bridges shall:

1. Be inspected regularly. A daily maintenance log as required by DOB must be maintained onsite at all times (sample checklist attached)
2. Be maintained lit at all times. The underside of the sidewalk shed shall be lighted at all times either by natural or artificial lights. The level of illumination shall be the equivalent of that produced by 200 watt, 3400 lumen minimum, standard incandescent lamps enclosed in vandal proof fixtures and spaced fifteen feet (15') apart and eight feet (8') above the floor level.
3. Have broken lights, missing cages or any repairs to defective parts made immediately no later than 24 hours of notification.
4. Have all posts near school exits/doors, play grounds and schools with grade Pre-K to Grade 5 padded and taped up to a height of five feet (5').
5. Tamper-Resistant Fasteners: All fasteners and connections used in the construction of sheds shall be tamper-resistant type. Tamper-resistant fasteners shall be used in such manner as to prevent unauthorized removal or loosening of any part of the shed. Specialized tools shall be required for removal.
 - a. Provide tamper-resistant fasteners for connection of all components and materials of the shed, including but not limited to pipe bracing, pipe railings, beam clamps, couplings, outriggers, extensions, protective guards, and enclosure walls built around the perimeter of the shed deck.
 - b. Bolts shall have tamper-resistant heads.

- c. Tamper-resistant nuts
 - i. Nuts shall be conical shape with multiple slots, requiring specialized socket tool for installation and removal. Corrosion resistant zinc alloy (Zamac 5 - AC41A). Compressive strength, 87,000 psi. Shear strength, 38,000 psi. Impact strength (CHARPY), 48 ft.lbs. Hardness BHN, 91. Size and threads as required to suit studs and bolts. Remove all sharp edges.
 - 1. Manufacturers:
 - 2. Trident Tamper-Resistant Nuts; Tanner Bolt & Nut Corp., 4302 Glenwood Road, Brooklyn, NY 11210. Telephone 718 434-4500.
 - 3. Trigr groove Tamper-Resistant Nuts; Fastenal Company, Farmingdale, NY. Telephone 516 391-0980.
 - ii. Provide zinc plated hex nuts, cylindrical spacers, and/or washers beneath tamper-resistant nuts where required for a proper connection. Fully tighten the entire assembly for tamper resistance. The diameter of the tamper-resistant nut shall not exceed the outside dimension of a hex nut or spacer beneath it, in order to prevent unauthorized removal.
 - iii. Fully tighten all fasteners. Wherever a standard nut is used it shall be fully tightened and a tamper-resistant nut shall be installed over it to prevent unauthorized removal. Where through bolts or rods are used, provide tamper resistant devices at both ends, or weld one end to prevent turning.
- 6. Have all nuts and bolts taped and padded up to a height of five feet (5').
- 7. Not have any storage of work materials or debris on top of any part of the Sidewalk Bridge.
- 8. Have a stamped, approved, engineer design for any Sidewalk Bridge supporting scaffolding on top of bridge.
- 9. Have a Professional Engineer (PE) letter confirm the sidewalk bridge including catchalls has been constructed to hold a minimum of 300 pounds per square foot minimum. (PSF)
- 10. Sidewalk sheds that provide a base for a scaffold or contractor's shed shall be designed by a professional engineer (PE). The ground where the shed is to be constructed shall be examined by an engineer to determine it is capable of supporting the total load.
- 11. The PE of record shall inspect and certify the Sidewalk bridge installation prior to erection of scaffolding on top of the bridge.
- 12. The PE of record shall re-inspect and re-certify the Sidewalk Bridge at a minimum of 6 months or at the request of the SCA Safety Unit.
- 13. Anytime a sidewalk bridge has been damaged or displaced the Professional Engineer (PE) is to re inspect and re certify the section(s) repaired.
- 14. Be broom swept each night to remove debris when jobsite is active.
- 15. Not block or impede the use of any doors located on the occupied school premise.
- 16. Not be removed until all work and FID inspections are complete above the first floor windowsill.
- 17. Have protection provided to the public during the installation and removal of the sidewalk bridge. (barriers, flag persons, signs, caution tape etc.)
- 18. Have mesh netting and chain link fence installed from the full underside of the sidewalk bridge deck to the ground, in accordance with the Approved Site Safety Plan.
- 19. Provide protection for the full width of the sidewalk. Catchalls shall be provided on all outward facing perimeter edges of the sidewalk bridge deck including ends when full coverage of the

sidewalk can not be obtained and at all times where half the height of the building requirement is not met. Wire mesh or mesh netting is not to be used in lieu of a solid catchall.

20. Extend parallel with the curb at least twenty feet (20') beyond the ends of all faces of the structure property.
21. Gaps created between the parapet boards and sidewalk bridge decks are to be covered in sufficient strength and manner so as to prevent materials from falling through the openings. See A&E Approved Detail.

Sidewalk Bridge Electrical Requirements

1. Have the sidewalk bridge grounded on occupied schools in accordance with the following;
 - a. All temporary wiring shall be installed in accordance with the requirements of the Bureau of Electrical Control, NEC and NYC Building Code
 - b. Conduits shall be permanently grounded to the permanent building ground system. In addition to the permanent ground a temporary grounding system is to be provided and shall consist of driven rod electrodes with a resistance to ground not to exceed 25 ohms. Where the resistance is above 25 ohms, additional electrodes connected in parallel shall be used.
 - c. The path from circuits, equipment, structures and conduit or enclosures to ground shall be permanent and continuous, have ample carrying capacity to conduct safely the currents liable to be imposed on it and have the impedance sufficiently low to limit the potential above ground and to result in the operation of the over-current devices in the circuit.
 - d. Grounding circuits shall be checked to ensure that the circuit between the ground and the grounded power conductor has a resistance, which is low enough to permit sufficient current to flow to cause the fuse or circuit breaker to interrupt the current.
2. Provide vandal resistant light fixtures with wire guard, and with incandescent or self-ballasted compact fluorescent lamps. Provide and maintain temporary lighting at all times, including making repairs due to vandalism. Temporary lighting wiring shall be run in rigid galvanized conduit (RGC). The conduit shall be run exposed and secured, in an approved manner, below the shed. The Contractor shall provide branch circuit wiring from a panel in the building and run three THW conductors (Black-White-Green) per circuit. Core drill (2") the conduit entrance into the building and insert a 1½" threaded sleeve. The Contractor shall remove the LB conduit and wires and place a threaded cap on the sleeve thru the building after temporary lighting is removed. The Contractor shall provide a schematic layout of sidewalk shed lighting.
3. The Licensed Electrician responsible for installation of the temporary electrical service is to provide a certificate of inspection from NYC Bureau of Electrical Control, or in lieu of said inspection, a Certification letter executed by the Licensed Electrician attesting that the temporary service has been installed in accordance with all applicable codes and that it meets the following minimum requirements:
 - a. All power to the electrical shed installation is ground fault interruption (GFI) protected as per NEC NYC amended section 590.6
 - b. The installation is properly grounded and bonded as per NEC Article 250
 - c. All raceways are terminated and supported properly as per NEC article 300; and
 - d. The installation does not pose a safety hazard to the public
 - e. Each statement must be on the licensed Electrician's company letterhead and must be signed and sealed by the Licensed Electrician.

Protection of Adjoining Property Owned By The Department of Parks & Recreation (DPR) and/or private property owners.

Every effort shall be made to minimize intrusion on adjoining property. All work shall be in accordance with NYC Department of Building Codes and OSHA regulations. Where required, Site protection options shall be reviewed by the SCA Safety Unit during the Contractor's development of the Site Safety Plan.

TEMPORARY FENCES

1. Temporary chain link fence with base supports which do not penetrate ground are not permitted for use as a construction fence. (Note: Exception to the use of a temporary fence will be determined on a site specific basis by the SCA Safety Unit).
2. Chainlink fence shall have a top, mid and bottom rail installed. Fine mesh debris netting shall be installed plumb against the fence.
3. All temporary construction fences shall be in accordance with DOB regulations
4. Temporary fencing installed on Sidewalks/streets shall conform to DOT regulations and subject to approval by the SCA Safety Unit
5. Construction fence gates to be inswinging at all times.

SITE SAFETY PLAN REQUIREMENTS

1. Submit to the SCA for review (by the SCA or its consultant) a Site Safety Plan(s) prepared and signed by a NYC Licensed Site Safety Manager. The Plan(s) shall be complete reflecting the entire site and shall show any phased protection. (See sample checklist for Site Safety Plans attached herein)
2. The Site Safety Plan shall include the following verbage as per Department Of Buildings 790-A:
All workers employed on the site will receive a Site Specific Safety Orientation program addressing hazardous activities on each job.
Site Safety Plan must include statement prior to performing any work on the project that all workers have successfully completed a 10-Hour OSHA course within the previous five calendar years.
3. The Site Safety Plan(s) shall include but shall not be limited to include notes, sidewalk bridges, scope of work, phasing of work where applicable, fences, egress, scaffolding, scaffold stair tower locations, fire protection, crane locations, FDNY holding areas, etc. They should address any potential interaction between the building occupants or general public and exposure to the construction process.
4. The Site Safety Plan(s) shall address all areas outside and within the property lines, as well as within the building, as required. They should address any multiple phasing periods by preparing separate drawing to represent each phase.
5. Other than full street closing, (sidewalk – street – sidewalk) no partial closing shall be allowed, notwithstanding **Chapter 33** Building Code. The Contractor/CM shall be required to install and maintain sidewalk sheds and shall not be permitted to obtain partial closing permits.
6. All sheds shall be installed with approved lighting maintained by the CM/Contractor per NYC Building Code - **Chapter 33**.
7. The areas within the property lines shall receive protection via sheds, fences, etc, necessary to provide proper protection to the school population, workers and pedestrians.
8. The installation of sidewalk sheds and/or fences should be performed in the most conservative manner and must be in place prior to start of any work. Likewise as work operations are completed, the sidewalk sheds and/or fencing should not be removed until the last operation of work which requires sheds and/or fences is completed and all required technical inspections are completed and obtained by the SCA Project Officer.

9. The Site Safety Plan shall also indicate location of high voltage power lines which may impact the installation of Sidewalk bridging as well as scaffolding.
10. The movement of sidewalk sheds along the sidewalk to follow the movement of the hanging scaffold or window replacement is not permitted. Sidewalk sheds and/or fences shall be installed and maintained continuous around the sidewalk until the last operation of work requiring sheds is completed.
11. Upon receipt and review of the Site Safety Plan(s), the PO's should meet with the principals to discuss the proposed plan(s) impact on school security and phasing.
12. Subject to the terms of the contract, changes to the Site Safety Plan(s), sidewalk sheds, fencing, security, etc. may not constitute a basis for a change order for extra work.
13. The PO's and CM's shall immediately direct the GC's to prepare and submit the Site Safety Plans(s) along with any proposals for additional work within (5) Days.

311 Sign Posting Requirements

1. In the interest of Public Safety, the Department of Buildings has enacted a rule to help and encourage construction workers to report unsafe job sites.
2. Effective September 3, 2004, all construction sites will be required to post signs with the following wording:

To Anonymously Report Unsafe Conditions at this Work Site, Call 311

In Spanish: Para Reportar Condiciones Peligrosas En Un Sitio De Trabajo, Llame Al 311. No Tiene Que Dar Su Nombre.

FDNY Sign Posting Requirements

"No Smoking," signs to be conspicuously posted on sidewalk bridge and around the site.

Sign Requirements:

Each side of a construction site that fronts on the street or other public way must have prominently displayed signs.

The signs must be placed no higher than 12 feet above the ground level.

The letters on the signs must be 6 inches high or greater.

The letters on the sign must be in black and the background must be in white.

The language must be in English and Spanish.

DIAGRAMS

Continued on next page.

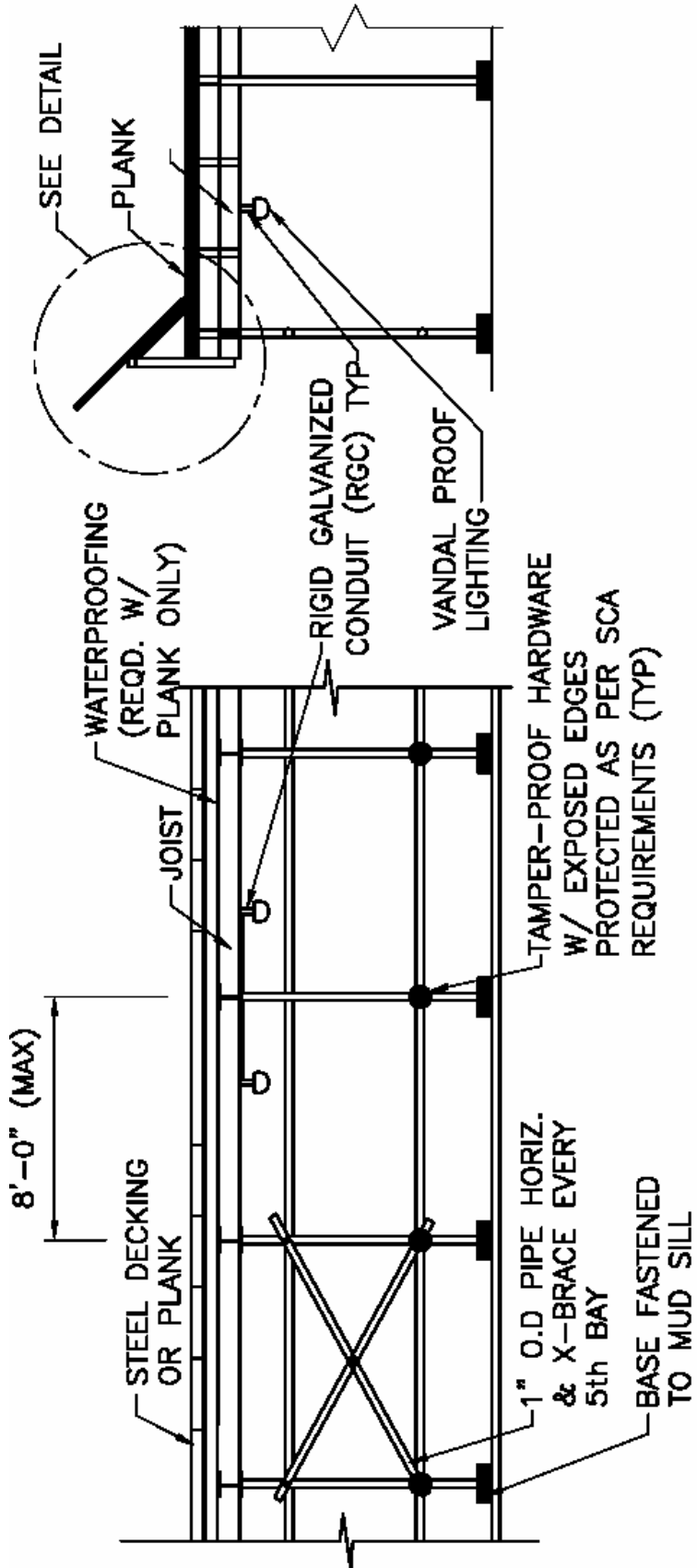

SIDEWALK SHED SECTION

SIDEWALK SHED ELEVATION

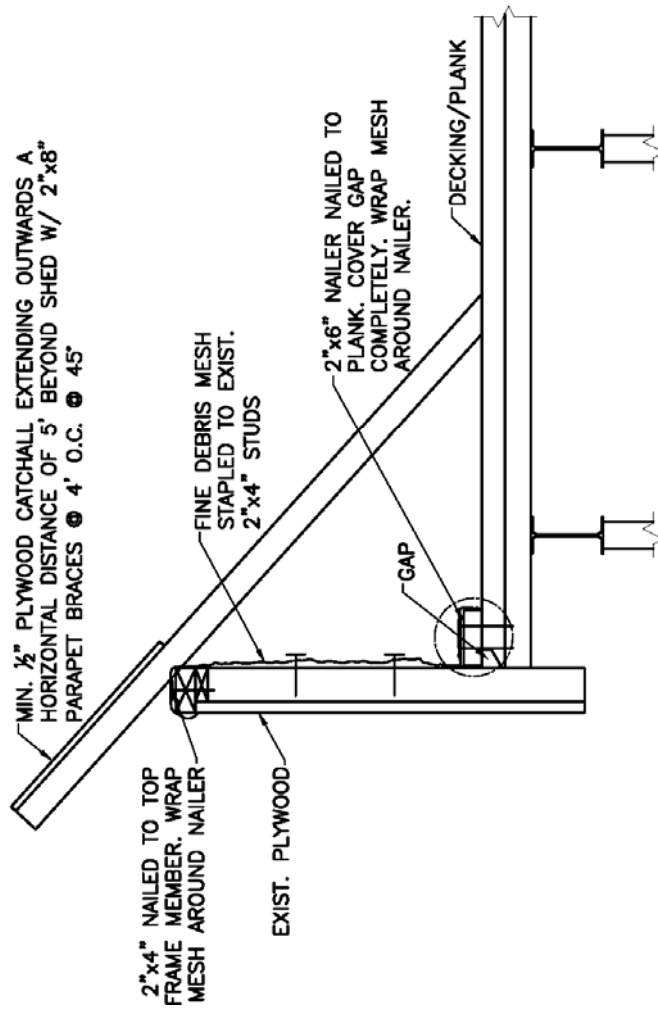

DETAIL

NOTE:

1. INSPECT TO INSURE PLANKS/DECKING AREA IS CLEAN OF DEBRIS.
2. ASSURE GAP IS CLEAN OF DEBRIS.
3. INSTALL DEBRIS NET AS INDICATED.
4. REPAIR MESH THROUGH DURATION OF PROJECT.
5. ALL GAPS BETWEEN THE PARAPET WALL AND SIDEWALK BRIDGE DECKING TO BE SOLIDLY CLOSED AS SHOWN. CONTRACTOR MAY UTILIZE EQUIVALENT MEANS OF PROTECTION, SUBJECT TO SCA APPROVAL.

Part 14 Form: Site Safety Plan Submission



SITE SAFETY PLAN SUBMISSION FORM

Project Officers to complete this form and attach it to the site safety plan before submitting it to the Safety Unit. Plans without this form will not be accepted. Minimum **Four (4)** copies of Plans are to be submitted.

1) School/Site: _____ 2) District: _____ 3) LLW #: _____

4) Address: _____ 5) Date submitted: _____

_____ 6) No. of Copies Submitted _____

7) Initial Submission Resubmission

8) **Scope of Work (check all that apply- for additional information use extra sheets):**

a. Internal b. External c. New School/ Addition

- | | | |
|---|--|---|
| <input type="checkbox"/> Science lab | <input type="checkbox"/> Safety system | |
| <input type="checkbox"/> Auditorium upgrade | <input type="checkbox"/> Parapet | <input type="checkbox"/> Paved area |
| <input type="checkbox"/> P.A. System | <input type="checkbox"/> Roof | <input type="checkbox"/> Retaining walls |
| <input type="checkbox"/> Fire alarm system | <input type="checkbox"/> Exterior Masonry | <input type="checkbox"/> Window replacement |
| <input type="checkbox"/> Other _____ | <input type="checkbox"/> Flood elimination | <input type="checkbox"/> Other _____ |

9) Staging required: Interior Exterior 10) Phasing required: Yes No

11) Crane on site: Yes No

12) Does S.S.P include statement relating to D.O.B -790A : Yes No

13) Contractor: _____ Phone: _____

14) NYC Site Safety Manager/ & License No.: _____
(Company/Consultant Name)

15) Submitted by:

a). S.C.A Project Officer - (Print Name/Signature) _____

Cell. No. _____ e-mail address: _____

b). Construction Manager - (Print Name/Signature) _____

Cell. No. _____ e-mail address: _____

FOR OFFICE USE ONLY

Date submitted to Reviewer: _____ Date returned to PO: _____

Date Returned from Reviewer: _____

- Approved Approved as noted Disapproved Revise & Resubmit

Resubmittal No.: _____

Part 14 Form:

Site Safety Plan Sign-Out Sheet



SITE SAFETY PLAN SIGN-OUT SHEET

Date:

School:

LLW#:

Number of copies:
picked up

P.O. Name

P.O. Signature:

_____ -

Part 14 Checklist: Site Safety Plan Checklist

Site Safety Plan Checklist

A Site Safety Plan should include the following before being submitted:

- ✓ Location of all construction fences around job site and/or mobilization area.
- ✓ Locations of all gates fences.
- ✓ Location of guard rail around excavation during excavation, when required.
- ✓ Horizontal and vertical netting program, including details of the initial installation, of horizontal jumps
- ✓ Vertical installations, and designated crane and derrick lifting areas where horizontal netting is omitted.
- ✓ Location of required sidewalk sheds.
- ✓ Location of temporary walkways.
- ✓ Location of foot bridges and motor vehicle ramps.
- ✓ Protection of site excavation, when required.
- ✓ Location of street and sidewalk closing(s).
- ✓ Approximate location of material and personnel hoist(s) and loading areas.
- ✓ Approximate location of all crane and derrick loading areas, if required.
- ✓ Location of surrounding buildings, indicating occupancy, height, and type of roof where required.
- ✓ Location of standpipe system and siamese hose connection(s).
- ✓ Location of temporary elevator for Fire Department use when building is above 75 feet in height.
- ✓ Location of all contractor's exterior staging areas, debris container etc.
- ✓ Safety netting and scaffolding, when required by Section BC - 3308 .
- ✓ Sidewalk and roadway widths, all traffic information, and all exits from job site.
- ✓ Location of all exits.
- ✓ Location of scaffolding& stair towers.
- ✓ Location of fire hydrants (and other forms of fire protection).
- ✓ Interior of building as required
- ✓ Plan reflects entire site.
- ✓ Plan shows phased protection plan.
- ✓ FDNY closure of exits
- ✓ FDNY location of 'holding areas'
- ✓ Statement of "D.O.B-790A" relating to the 10-Hour OSHA training course for workers.
- ✓ A statement in the site Safety Plan that all workers employed on the site will receive a Site Specific Safety orientation program addressing hazardous activities on each job.
- ✓ A Statement to include prior to performing any work on the project that all workers have successfully completed a 10-Hour OSHA course within the previous five calendar years.
- ✓ Location of overhead power lines.

Part 14 Checklist: Sidewalk Bridge Inspection

Sidewalk Bridge Inspection Checklist

1. _____ Debris on top of the sidewalk sheds.
2. _____ Materials stored on top of the sidewalk sheds
3. _____ Gaps or openings on sidewalk sheds.
4. _____ Parapet Panels are missing.
5. _____ Solid Barrier or Chain Link Fence and Debris netting is missing/damaged.
6. _____ View Panels in Solid Barrier Fence is missing/damaged.
7. _____ Tamper proof nuts have not been installed.
8. _____ Bolts under the sidewalk shed have not been padded/covered or are missing.
9. _____ Nails must be installed in the mud sills.
10. _____ Lights under the sidewalk sheds are broken or blown out.
11. _____ Vandal proof cages are missing or damaged.
12. _____ Electrical conduit under the sidewalk sheds is damaged.
13. _____ List Permit No. and Expiration Date on Sign.
14. _____ All cross bracing must be in place and secure.
15. _____ Daily log of Sidewalk Shed inspection must be maintained.

Part 14 Fact Sheet: New Inspection Maintenance Log Requirement



**New Inspection Log Requirement
August 11, 2008
FACT SHEET**

New Inspection Maintenance Log Requirement

We're Dedicated to Safety!

To ensure contractors are properly maintaining supported scaffolds and sidewalk sheds, effective immediately, all supported scaffolds and sidewalk sheds must be inspected daily and the results of these inspections must be recorded in a maintenance log, readily available on-site at all times. This maintenance log must include, at minimum, the following information:

General Information	Permit #
Name of Scaffold Erector	Installation Date _____ Expiration _____
Renters Name	Phone #
Shed type Light __ Med. __ Heavy __ Duty	Drawings on Site for inspection?
Specific Information	Scaffold Height _____
Number of platforms decked _____	Are the base plates & mudsills secured?
Are the signs on the parapets?	Are all the Scaffold pins & bolts installed?
Maintenance Information	Are the legs and poles plumb, braced and not displaced?
Are cross braces fully attached, not bent, and not missing?	Are tie-ins correctly spaced, properly secured & the correct amount?
Are pipe clamps tight?	Are window jacks tight?
Are all the planks secured?	Are decking and planks in good condition?
Is deck fully planked?	Are there gaps or open spaces on decking?
Are the guardrails & toe boards secured at all places where required?	Is the netting extension of full length and height?
Is the netting secured?	Is the parapet the proper height and secured?
Are the lights working?	Is the deck clean and free of debris?
Name:	
Signature:	Date:

safety • service • integrity

Part 15: Scaffolds

INTRODUCTION

On School Construction Authority Projects where Scaffolding is to take place, Federal OSHA standards, current New York City Department of Building Codes and School Construction Authority Safety Program & Procedures Manual and any other agencies laws, regulations and procedures shall be implemented. The most stringent of these standards shall be applicable.

BASIC TERMINOLOGY

Definitions for the following terms are listed alphabetically within the Glossary located at the back of this publication:

- Adjustable Suspension Scaffold
- Bearer
- Boatswains' Chair
- Body Belt
- Body Harness
- Brace
- Bricklayers' Square Scaffold
- Carpenters' Bracket Scaffold
- Catenary Scaffold
- Cleat
- Competent Person
- Continuous Run Scaffold
- Coupler
- Crawling Board
- Deceleration Device
- Double Pole
- Equivalent
- Exposed Power
- Eye
- Mobile Scaffold
- Multi-Level Suspended Scaffold
- Multi-Point Adjustable Suspension Scaffold
- Needle Beam Scaffold
- Open Side and Ends
- Outrigger
- Overhand Bricklaying and Related Work
- Personal Fall Arrest System
- Platform
- Hoist, Power Operated
- Qualified
- Rated Load
- Repair Bracket Scaffold
- Roof Bracket Scaffold
- Runner
- Scaffold
- Self-Contained Adjustable Scaffold
- Shore Scaffold
- Single-Point Scaffold

- Fabricated Decking
- Fabricated Frame Scaffold
- Failure
- Float Scaffold
- Form Scaffold
- Guardrail System
- Hoist
- Horse Scaffold
- Interior Hung Scaffold
- Ladder Jack Scaffold
- Landing
- Large Area Scaffold
- Lean-To Scaffold
- Lifeline
- Lower Level
- Masons' Adjustable Supported Scaffold
- Masons' Multi-Point Adjustable Suspension Scaffold
- Maximum Intended Load
- Stair Tower
- Stall Load
- Step, Platform, and Trestle Ladder Scaffold
- Stonesetters' Multi-Point Adjustable Suspension Scaffold
- Supported Scaffold
- Suspension Scaffold
- System Scaffold
- Tank Builders' Scaffold
- Top Plate Bracket Scaffold
- Tube and Coupler Scaffold
- Tubular Welded Frame Scaffold
- Two-Point Suspension Scaffold
- Unstable Objects
- Vertical Pickup
- Walkway
- Window Jack Scaffold



SCA GENERAL REQUIREMENTS

1. When using any type of scaffold system on any SCA Project, the following provisions, as appropriate to the system in use shall be met. Furthermore, requirements of current NYC Building Code and Local Law 52-05 shall apply.
2. Scaffold systems assembled at any location that provide a work platform 40 feet in height or more measured from a lower level at any exposure shall conform to the requirements of Local Law 52-05 and all workers involved in the construction, dismantling and use of these scaffolds will complete a recognized training program per Local Law 52-05 (32 hour for modifiers/installers and 4 hour user for all others)
3. Permit required supported scaffold must have at least (2) workers with 32 hour training to assist in modification, repair or alteration while work is in progress
4. Permits shall be obtained from the Building Department for the school premise where the work is taking place and the permit is to be posted on the job site.
5. The PE designed and DOB stamped and approved Scaffold design drawing shall be kept readily available onsite for inspection
6. Daily inspection/maintenance log on the scaffold shall be maintained by the competent person and be readily available for inspection as per DOB regulations

7. The PE of record shall inspect and certify the scaffold as being installed in accordance with filed plans and drawings. Any deviations in the field shall constitute the plans to be revised and re-filed with DOB for approval.
8. The Special Rigger shall have an original copy of the Riggers License readily available for review on site.
9. The Special Rigger shall be on site when the hanging scaffold is moved to a new location.
10. A Designated Riggers' Foreman shall be present on site while using a hanging scaffold. Rigger's foreman shall have in his possession a valid Department of Building issued "tear-off" card
11. The Designated Riggers' Foreman shall conduct and document daily inspections of all hanging scaffold components. A record of such inspections shall be kept and maintained at the job site and shall be readily available upon request. The record shall be signed by the individual responsible for the inspection and shall also show the individual's name clearly and legibly printed.
12. All employees shall have training and documentation of completion of training. Workers involved in the erection, dismantling or modification of any supported scaffold must have completed a recognized 32 hour training program. Anyone using a suspended scaffold must have completed a recognized 16 hour training program. All workers must carry aforementioned cards on their person.
13. A Certificate of Fitness shall be issued to each scaffold user by the Special Master, Special Rigger, or Rigging Foreman.
14. All suspended scaffolds are to be designed by a Professional Engineer; a copy of the design drawing is to be maintained at the jobsite.
15. Vertical fire retardant fine mesh debris netting shall be provided on the exterior side of all suspended and supported scaffolds. The vertical netting is required in addition to the sidewalk sheds, fences, or railings required by the site safety plan.
16. In addition to the scaffold's cross braces a top-rail, mid-rail and toe board are to be installed along every unprotected platform edge wherever there is a fall hazard of six feet or greater.
17. A Professional Design Drawing shall be required for all supported scaffolds with a height to base width (including outrigger supports, if used) ratio of more than four to one (4:1). Details for tie-backs shall include substrate construction (cavity, structural beam, etc.) PE to also consider layout of site including any metal grating, stairs, lower roofs, etc, that may be used to support the scaffold. The Professional Engineer (PE) on record shall re-inspect and recertify the scaffold at minimum every six (6) months or at the request of the SCA Safety Director/Safety Inspector. All PE drawings and Inspection letters must be readily available for inspection on site by SCA Safety Officer.
18. Lighting shall be provided on scaffolds throughout all platforms and all stair towers up to and including the work area(s). Lights are to remain lit at all times while work is taking place. Stair towers shall be outside of system so as to not impede walkways.
19. All temporary lighting shall be in accordance with BEC, NEC and NYC DOB codes and regulations
20. Wiring shall be suspended from approved insulations or non-conductive hangars.
21. Outrigger platforms (bicycles) shall only be used as work platforms for individuals, therefore a fully planked platform on the scaffold frame bearer must be provided for material handling and access. The fully planked platform is to be within a maximum six feet (6') above or below the outrigger and secured.
22. Scaffold planks to be inspected before installation. Rotted/split planks shall not be used.
23. Scaffold platforms and outriggers are to be cleaned daily of work materials and debris.

24. A Professional Engineer (PE) is to provide a stamped review letter that qualifies any electrical powered hoist installed on a scaffold system. Copy of letter is to be posted on site and provided to SCA Safety.
25. All individuals who erect, dismantle, repair, modify or work from supported scaffolds shall be required to comply with all training requirements set forth in New York City Local Law #52 of Title 26 and current NYC Department of Building Code.
26. Stair towers shall be provided as the means of access to scaffold working levels above or below ground except where the nature or the progress of the work prevents their installation in which case ladders or other safe means of access shall be provided.
27. A minimum of one (1) stair tower shall be installed on each building elevation but in no case shall the travel distance on the scaffold between stair towers be more than 300 feet.
28. Prior to installing tarps on any portion of exterior supported scaffolds a Professional Engineer (PE) shall provide a stamped review letter that addresses wind loads and proper means of attachment.
29. All exterior supported scaffolds are to be provided with vertical fire retardant fine mesh debris netting for their full height and width when there is exposure to the public, adjacent property or site employees. Exposure to the public, adjacent property or site employees shall refer to any exterior supported scaffold which is opposite a street, public way, employee walkway or other open area intended for public use or which is opposite any side of rear lot line. The vertical netting shall be required in addition to the sidewalk sheds, fence or railings.
30. Where it is possible for the public to pass under, or next to a scaffold, the space between the top rail and toeboard shall be enclosed with a wire screen composed of not less than no.18 steel wire gage with a maximum ½ inch (13mm) mesh or equivalent synthetic safety netting. For the purpose of this provision the term “where it is possible for the public to pass under, or next to a scaffold” shall mean when the setback from the scaffold to the area used by the public is a distance equal to or less than half the height of the scaffold.
31. Fine mesh fire retardant debris netting is required on all scaffolds on all SCA Projects (both Line projects and CIP projects)
32. The installation and use of Mast Climbers shall be in accordance with New York City Department of Cranes and Derricks. Training cards shall be required for users of Mast Climbers in accordance with Local Law 52 regulations.
33. Suspending scaffolds by parapet hooks is prohibited except as follows:

In cases where due to unusual roof types, it may not be possible to utilize the outrigger type scaffolding it will be acceptable, as a last resort, to suspend scaffolds by hooks from parapets under the following conditions:

 - a. The building is a new school or addition only. (This Bulletin does not apply to existing buildings or C.I.P. projects).
 - b. The Architect or Engineer of record certifies in writing the reason the outrigger type scaffolding is not feasible.
 - c. The Contractor shall protect the coping, parapet and the surrounding construction from damage due to the Contractor's operations. If the Contractor damages the coping, parapet or the surrounding construction, he shall repair and/or replace same at no cost to the Authority.
 - d. The scaffold shall not be suspended from the parapet before the parapet can develop the strength to support the imposed loads.
 - e. A professional engineer licensed to practice in the State of New York certifies that such parapet, is adequate to support the loads intended to be imposed thereon. Such certification shall be kept on the job site available for examination.

- f. Upon delivery of the scaffold equipment to the site, the supplier of such equipment shall furnish a certificate from an independent testing laboratory or a licensed Professional Engineer, stating that physical tests of a prototype of the equipment were conducted and that such equipment is capable of withstanding at least four times the maximum allowable live loads. Such certificates shall be kept at the field office and shall be made available for inspection by representatives of the SCA and the N.Y.C. Department of Buildings.
- g. Scaffolds shall be tied into the building or structure, and means therefore shall be provided. Window cleaners' anchors, window frames, mullions, or similar elements shall not be used as tie-in anchors or brace-back points. Detail for tie-backs shall be provided by Professional Engineer of Design and must be inspected by same when scaffold system has been installed.

SCOPE AND APPLICATION

This subpart applies to all scaffolds used in workplaces covered by this Part. It does not apply to crane or derrick suspended personnel platforms, which are covered by Fall Protection. The criteria for aerial lifts are set out exclusively in section Aerial lifts.

GENERAL REQUIREMENTS

This section does not apply to aerial lifts, the criteria for which are set out exclusively in section Aerial lifts.

CAPACITY

1. Except as provided in paragraphs 2,3,4,5 and Fall Protection on page 344 of this part, each scaffold and scaffold component shall be capable of supporting, without failure, its own weight and at least 4 times the maximum intended load applied or transmitted to it.
2. Direct connections to roofs and floors, and counterweights used to balance adjustable suspension scaffolds, shall be capable of resisting at least 4 times the tipping moment imposed by the scaffold operating at the rated load of the hoist, or 1.5 (minimum) times the tipping moment imposed by the scaffold operating at the stall load of the hoist, whichever is greater.
3. Each suspension rope, including connecting hardware, used on non-adjustable suspension scaffolds shall be capable of supporting, without failure, at least 6 times the maximum intended load applied or transmitted to that rope.
4. Each suspension rope, including connecting hardware, used on adjustable suspension scaffolds shall be capable of supporting, without failure; at least 6 times the maximum intended load applied or transmitted to that rope with the scaffold operating at either the rated the rated load of the hoist, or 2 (minimum) times the stall load of the hoist, whichever is greater.
5. The stall load of any scaffold hoist shall not exceed 3 times its rated load.
6. Scaffolds that require a permit shall be designed by a Professional Engineer and shall be constructed and loaded in accordance with that design. All other scaffolds may be designed by a qualified person. Non-mandatory Appendix A subpart Scaffolds 29CFR 1926 contains examples of criteria that will enable an employer to comply with this section.

SCAFFOLD PLATFORM CONSTRUCTION

1. Each platform on all working levels of scaffolds shall be secured and fully planked or decked between the front uprights and the guardrail supports as follows:
2. Each platform unit (e.g., scaffold plank, fabricated plank, fabricated deck, or fabricated platform) shall be installed so that the space between adjacent units and the space between the platform and the uprights is not more than 1 inch (2.5 cm) wide, except where the employer can demonstrate that a wider space is necessary (for example, to fit around uprights when side brackets are used to extend the width of the platform).



Exception: The requirement in paragraph 2 to provide full planking or decking does not apply to platforms used solely as walkways or solely by employees performing scaffold erection or dismantling. In these situations, only the planking that the employer establishes in necessary to provide safe working conditions is required.

3. Where the employer makes the demonstration provided for in paragraph 2 of this section, the platform shall be planked or decked as fully as possible and the remaining open space between the platform and the uprights shall not exceed 9 ½ inches (24.1 cm).
4. Except as provided in paragraphs 5 and 6 of this section each scaffold platform and walkway shall be at least 18 inches (46 cm) wide. Full body harness as fall protection must be worn and used .
5. Each ladder jack scaffold, top plate bracket scaffold, roof bracket scaffold, and pump jack scaffold, and pump jack scaffold shall be at least 12 inches (30 cm) wide. There is not minimum width requirement for boatswains' chairs.



Note: Pursuant to an administrative stay effective November 29, 1996 and published in the FEDERAL REGISTER on November 25, 1996, the requirement in paragraph 6 that roof bracket scaffolds has been completed, whichever is later.

6. Where scaffolds must be used in areas that the employer can demonstrate are so narrow that platforms and walkways cannot be at least 18 inches (46 cm) wide, such platforms and walkways shall be as wide as feasible, and employees on those platforms and walkways shall be protected from fall hazards by the use of guardrails and /or personal fall arrest systems.
7. Except as provided in paragraphs 8 and 9 of this section, the front edge of all platforms shall not be more than 14 inches (36 cm) from the face of the work, unless guardrail systems are erected along the front edge and/or personal fall arrest systems are used in accordance with Fall protection of this section to protect employees from falling.
8. The maximum distance from the face for outrigger scaffolds shall be 3 inches (8 cm).
9. The maximum distance from the face for plastering and lathing operations shall be 18 inches (46 cm).
10. End each platform, unless cleated or otherwise restrained by hooks or equivalent means, shall extend over the centerline of its support as least 6 inches (15 cm).
11. Each end of a platform 10 feet or less in length shall not extend over its support more than 18 inches (46 cm), unless it is designed and installed so that the cantilevered portion of the platform is able to support employees without tipping, or has guardrails which block employee access to the cantilevered end.
12. The end of a platform 10 feet (3048 mm) or less in length shall not extend over the centerline of its support more than 12 inches (305 mm) unless the platform and its tiedown are designed by a qualified person or the platform has guardrails to prevent access to the cantilevered end.

13. The end of a platform more than 10 feet (3048 mm) in length shall not extend over the centerline of its support more than 18 inches (457 mm) unless the platform and its tiedown are designed by a qualified person or the platform has guardrails to prevent access to the cantilevered end.
14. On scaffolds where scaffold planks are abutted to create a long platform, each abutted end shall rest on a separate support surface. This provision does not preclude the use of common support members, such as “T” sections, to support abutting planks, or hook on platforms designed to rest on common supports.
15. On scaffolds where platforms are overlapped to create a long platform, the overlap shall occur only over supports, and shall not be less than 12 inches and the platforms are nailed together or otherwise restrained to prevent movement.
16. At all points of a scaffold where the platform changes direction, such as turning a corner, any platform that rests on a bearer at an angle other than a right angle shall be laid first, and platforms which rest at right angles over the same bearer shall be laid second, on top of the first platform.

Wood platforms shall not be covered with opaque finishes, except that platform edges may be covered or marked for identification. Platforms may be coated periodically with wood preservatives, fire-retardant finishes, and slip-resistant finishes; however, the coating may not obscure the top or bottom wood surfaces. Platforms may not be covered by plywood.
17. Scaffold components manufactured by different manufacturers shall not be intermixed unless the components fit together without force and the scaffold’s structural integrity is not affected as certified by Professional Engineer of Record. Bicycles or scaffold outriggers designed with pins shall so be installed.
18. Scaffold components made of dissimilar metals shall not be used together unless a competent person has determined that galvanic action will not reduce the strength of any component to a level below that required by paragraph 1 in this section.

CRITERIA FOR SUPPORTED SCAFFOLDS

1. Supported scaffolds with a height to base width (including outrigger supports, if used) ratio of more than four to one (4:1) shall be restrained from tipping by guying, tying, bracing, or equivalent means as follows:
 - a. Guys, ties, and braces shall be installed at locations where horizontal members support both inner and outer legs.
 - b. Guys, ties and braces shall be installed according to the scaffold manufacturer’s recommendations or at the closest horizontal member to the 4:1 height and be repeated vertically at locations of horizontal members every 20 feet or less thereafter for scaffolds three (3) feet wide or less, and every 26 feet or less thereafter for scaffolds greater than three (3) feet wide. The top guy, tie or brace of completed scaffolds shall be placed no further than the 4:1 HEIGHT FROM THE TOP. Such GUYS, TIES AND BRACES SHALL BE installed at each end of the scaffold and at horizontal intervals not to exceed 30 feet. (measured from one end (not both) toward the other). First tie/brace shall be installed at scaffold 3 frames high.
 - c. Ties, guys, braces or outriggers shall be used to prevent the tipping of supported scaffolds in all circumstances where a centric load, such as a cantilevered work platform, is applied or is transmitted to the scaffold.
2. Supported scaffold poles, legs, posts, frames and uprights shall bear on base plates and mud sills or other adequate firm foundation. Unusable scaffold planks shall not be used as mudsills.
 - a. Footings shall be level, sound, rigid, and capable of supporting the loaded scaffold without settling or displacement.

- b. Unstable objects shall not be used to support scaffolds or platform units
 - c. Unstable objects shall not be used as working platforms.
 - d. Front end loaders and similar pieces of equipment shall not be used to support scaffold platforms unless they have been specifically designed by the manufacturer for such use.
3. Supported scaffold poles, legs, posts, frames, and uprights shall be plumb and braced to prevent swaying and displacement. If cavity wall tie-in is required then substrate to be determined and tie-in must be in accordance with PE drawing.

CRITERIA FOR SUSPENSION SCAFFOLDS

1. All suspension scaffold support devices, such as outrigger beams, cornice hooks, parapet clamps, and similar devices, shall rest on surfaces capable of supporting at least 4 times the load imposed on them by scaffold operating at the rated load of the hoist (or at least 1.5 times the load imposed on them by the scaffold at the stall capacity of the hoist, whichever is greater).
2. Suspension scaffold outrigger beams, when used, shall be made of structural metal or equivalent strength material, and shall be restrained to prevent movement. All components shall be consistent with manufactured system.
3. The inboard ends of suspension scaffold outrigger beams shall be stabilized by bolts or other direct connections to the floor or roof deck, or they shall have their inboard ends stabilized by counterweights, except masons' multi-point adjustable suspension scaffold outrigger beams shall not be stabilized by counterweights. Counterweight system to be designed by PE.
4. Before the scaffold is used, direct connections shall be evaluated by a competent person who shall confirm, based on the evaluation, that the supporting surfaces are capable of supporting the loads to be imposed. In addition, masons' multi-point adjustable suspension scaffold connections shall be designed by an engineer experienced in such scaffold design. Design drawing shall be made readily available at site for inspection by SCA Safety Officer.
5. Counterweights shall be made of non-flowable material. Sand, gravel and similar materials that can be easily dislocated shall not be used as counterweights.
6. Only those items specifically designed as counterweights shall be used to counterweight scaffold systems. Construction materials such as, but not limited to, masonry units and rolls of roofing felt, shall not be used as counterweights.
7. Counterweights shall be secured by mechanical means to the outrigger beams to prevent accidental displacement without the wire rope kinking.
8. Counterweights shall not be removed from an outrigger beam until the scaffold is disassembled.
9. Outrigger beams which are not stabilized by bolts or other direct connections to the floor or roof deck shall be secured by tiebacks.
10. Tiebacks shall be equivalent in strength to the suspension ropes.
11. Outrigger beams shall be placed perpendicular to its bearing support (usually the face of the building or structure). However, where the employer can demonstrate that it is not possible to place an outrigger beam perpendicular to the face of the building or structure because of obstructions that cannot be moved, the outrigger beam may be placed at some other angle, provided opposing angle tiebacks are used.
12. Tiebacks shall be secured to a structurally sound anchorage on the building or structure. Sound anchorages include structural members, but do not include standpipes, vents, other piping systems, or electrical conduit.

13. Tiebacks shall be installed perpendicular to the face of the building or structure, or opposing angle tiebacks shall be installed. Single tiebacks installed at an angle are prohibited.
14. Parapets used in conjunction with parapet clamps used as tie-backs shall be inspected by PE for structural integrity prior to use
15. Suspension scaffold outrigger beams shall be:
 - a. Provided with stop bolts or shackles at both ends
 - b. Securely fastened together with the flanges turned out when channel iron beams are used in place or I-beams
 - c. Installed with all bearing supports perpendicular to the beam center line
 - d. Set and maintained with the web in a vertical position
 - e. When an outrigger beam is used, the shackle or clevis with which the rope is attached to the outrigger beam shall be placed directly over the centerline of the stirrup
16. Suspension scaffold support devices such as cornice hooks, roof hooks, parapet clamps, or similar devices shall be:
 - a. Made of steel, wrought iron, or materials of equivalent strength
 - b. Supported by bearing blocks
 - c. Secured against movement by tiebacks installed at right angles to the face of the building or structure, or opposing angle tiebacks shall be installed and secured to a structurally sound point of anchorage on the building or structure. Sound points of anchorage include structural members, but do not include standpipes, vents, other piping systems, or electrical conduit
17. Tiebacks shall be equivalent in strength to the hoisting rope.
18. When winding drum hoists are used on a suspension scaffold, they shall contain not less than four wraps of the suspension rope at the lowest point of scaffold travel. When other types of hoists are used, the suspension ropes shall be long enough to allow the scaffold to be lowered to the level below without the rope end passing through the hoist, or the rope end shall be configured or provided with means to prevent the end from passing through the hoist.
19. The use of repaired wire rope as suspension rope is prohibited.
20. Wire suspension ropes shall not be joined together except through the use of eye splice thimbles connected with shackles or cover plates and bolts.
21. The load end of wire suspension ropes shall be equipped with proper thimbles and secured by eye splicing or equivalent means.
22. Ropes shall be inspected for defects by a competent person prior to each workshift and after every occurrence which could affect a rope's integrity. Ropes shall be replaced if any of the following conditions exist:
 - a. Any physical damage which impairs the function and strength of the rope.
 - b. Any physical damage which impairs the function and strength of the rope.
 - c. Kinks that might impair the tracking or wrapping of rope around the drum(s) or sheave(s) or counter weights.
 - d. Any broken wires in one rope lay or three broken wires in one strand on one rope lay.
 - e. Abrasion, corrosion, scrubbing, flattening or peening causing loss of more than one-third of the original diameter of the outside wires.
 - f. Heat damage caused by a torch or any damage caused by contact with electrical wires.

- g. Evidence that the secondary brake has been activated during an overspeed condition and has engaged the suspension rope.
 - h. Excessive rust or weather worn ropes.
- 23. Swaged attachments or spliced eyes on wire suspension ropes shall not be used unless on wire suspension ropes shall not be used unless they are made by the wire rope manufacturer or a qualified person.
- 24. When wire rope clips are used on suspension scaffolds:
 - a. There shall be a minimum of 3 wire rope clips installed, with the clips a minimum of 6 rope diameters apart;
 - b. Clips shall be installed according to the manufacturer's recommendations.
 - c. Clips shall be retightened to the manufacturer's recommendations after the initial loading.
 - d. Clips shall be inspected and retightened to the manufacturer's recommendations at the start of each workshift thereafter and shall be included in daily inspection checklist.
 - e. U-bolt clips shall not be used at the point of suspension for any scaffold hoist.
- 25. Suspension scaffold power-operated hoists and manual hoists shall be tested by a qualified laboratory.
- 26. Gasoline-powered equipment and hoists shall not be used on suspension scaffolds.
- 27. Gears and brakes of power-operated hoists used on suspension scaffolds shall be enclosed.
- 28. In addition to the normal operating brake, suspension scaffold power-operated hoists and manually operated hoists shall have a braking device or locking pawl which engages automatically when a hoist makes either of the following uncontrolled movements: an instantaneous change in momentum or an accelerated overspeed.
- 29. Manually operated hoists shall require a positive crank force to descend.
- 30. Two-point and multi-point suspension scaffolds shall be tied or otherwise secured to prevent them from swaying, as determined to be necessary based on an evaluation by a competent person. Window cleaners' anchors shall be used for this purpose.
- 31. Devices whose sole function is to provide emergency escape and rescue shall not be used as working platforms. This provision does not preclude the use of systems which are designed to function both as suspension scaffolds and emergency systems.

ACCESS

- 1. This paragraph applies to scaffold access for all employees. Access requirements for employees erecting or dismantling supported scaffolds are specifically addressed in paragraph 26 of this section.
- 2. When scaffold platforms are more than 2 feet (0.6m) above or below a point of access, portable ladders, hook-on ladders, attachable ladders, stair towers (scaffold stairways/towers), stairway-type ladders (such as ladder stands), ramps, walkways, integral prefabricated scaffold access, or direct access from another scaffold structure, personnel hoist, or similar surface shall be used, Crossbraces shall not be used as a means of access.
- 3. Portable, hook-on and attachable ladders (Additional requirements for the proper construction and use of portable ladders are contained in subpart Repair bracket scaffolds of this part- Stairways and Ladders) must be designed as part of system is used in lieu of stair access.

- a. Portable hook-on, and attachable ladders shall be positioned so as not to tip the scaffold
 - b. Hook-on and attachable ladders shall be positioned so that their bottom rung is not more than 24 inches above the scaffold supporting level
 - c. Hook-on and attachable ladders are used on a supported scaffold more than 35 feet (10.7m) high, they shall have rest platforms at 35-foot (10.7m) maximum vertical intervals
 - d. Hook-on and attachable ladders shall be specifically designed for use with the type of scaffold used
 - e. Hook-on and attachable ladders shall have a minimum rung length of 11 ½ inches
 - f. Hook-on and attachable ladders shall have uniformly spaced rungs with a maximum spacing between rungs of 16 ¾ inches
4. Stairway-type ladders shall:
- a. Be positioned such that their bottom step is not more than 24 inches (61 cm) above the scaffold supporting level
 - b. Be provided with rest platforms at 12 foot (3.7m) maximum vertical intervals
 - c. Have a minimum step width of 16 inches (41 cm), except that mobile scaffold stairway type ladders shall have a minimum step width of 11 ½ inches (30 cm)
 - d. Have slip-resistant treads on all steps and landings
5. Stairtowers (scaffold stairway/towers) shall be positioned such that their bottom step is not more than 24 inches (61 cm) above the scaffold support level.
6. A stairrail consisting of a toprail and a midrail shall be provided on each side of each scaffold stairway.
7. The toprail of each stairrail system shall also be capable of serving as a handrail, unless a separate handrail is provided.
8. Handrails, and toprails that serve as handrails, shall provide an adequate handhold for employees grasping them to avoid falling.
9. Stairrail systems and handrails shall be surfaced to prevent injury to employees from punctures or lacerations, and to prevent snagging of clothing.
10. The ends of stairrail system and handrails shall be constructed so that they do not constitute a projection hazard.
11. Handrails, and toprails that are used as handrails, shall be at least 3 inches (7.6 cm) from other objects.
12. Stairrails shall not be not less than 28 inches (71 cm) nor more than 37 inches (94 cm) from the upper surface of the stairrail to the surface of the tread, in line with the face of the riser at the forward edge of the tread.
13. A landing platform at least 18 inches (45.7 cm) wide by at least 18 inches (45.7 cm) long shall be provided at each level.
14. Each scaffold stairway shall be at least 18 inches (45.7 cm) wide between stairrails.
15. Treads and landings shall have slip-resistant surfaces.
16. Stairways shall be installed between 40 degrees and 60 degrees from the horizontal.
17. Guardrails meeting the requirements of paragraph 15 in section Fall Protection shall be provided on the open sides and ends of each landing.

18. Riser height shall be uniform, within $\frac{1}{4}$ inch, (0.6 cm) for each flight of stairs. Greater variations in riser height are allowed for the top and bottom steps of the entire system, not for each flight of stairs.
19. Tread depth shall be uniform, within $\frac{1}{4}$ inch, for each flight of stairs.
20. Ramps and walkways, Ramps and walkways 6 feet (1.8 m) or more above lower levels shall have guardrail systems which comply with subpart Fall Protection.
21. No ramp or walkway shall be inclined more than a slope of one (1) vertical to three (3) horizontal (20 degrees above horizontal).
22. If the slope of a ramp or a walkway is steeper than one (1) vertical in eight (8) horizontal, the ramp or walkway shall have cleats not more than fourteen (14) inches (35cm) apart which are securely fastened to the planks to provide footing.
23. Integral prefabricated scaffold access frames shall:
 - a. Be specifically designed and constructed for use as ladder rungs
 - b. Have a rung length of at least 8 inches (20 cm)
 - c. Not be used as work platforms when rungs are less than 11 $\frac{1}{2}$ inches in length, unless each affected employee uses Fall Protection, or a positioning device, which complies with Fall Protection
 - d. Be uniformly spaced within each frame section
 - e. Be provided with rest platforms at 35-foot (10.7 m) maximum vertical intervals on all supported scaffolds more than 35 feet (10.7m) high
 - f. Have a maximum spacing between rungs of 16 $\frac{3}{4}$ inches (43 cm). Non-uniform rung spacing caused by joining end frames together is allowed, provided the resulting spacing does not exceed 16 $\frac{3}{4}$ inches (43 cm)
24. Steps and rungs of ladder and stairway type access shall line up vertically with each other between rest platforms.
25. Direct access to or from another surface shall be used only when the scaffold is not more than 14 inches (36 cm) horizontally and not more than 24 inches (61 cm) vertically from the other surface.
26. Effective September 2, 1997, access for employees erecting or dismantling supported scaffolds shall be in accordance with the following:
 - a. The employer shall provide safe means of access for each employee erecting or dismantling a scaffold where the provision of safe access is feasible and does not create a greater hazard. The employer shall have a competent person determine whether it is feasible or would pose a greater hazard to provide, and have employees use a safe means of access. This determination shall be based on site conditions and the type of scaffold being erected or dismantled.
 - b. Hook-on or attachable ladders shall be installed as soon as scaffold erection has progressed to a point that permits safe installation and use.
 - c. When erecting or dismantling tubular welded frame scaffolds, (end) frames, with horizontal members that are parallel, level and are not more than 22 inches apart vertically may be used as climbing devices for access, provided they are erected in a manner that creates a usable ladder and provides good hand hold and foot space.
 - d. Cross braces on tubular welded frame scaffolds shall not be used as a means of access or egress.
 - e. All components of the scaffold system shall be installed as per manufacturer's recommendations and if different components are used then PE on record must certify in writing that the structural integrity of the scaffold is not compromised.

USE

1. Scaffolds and scaffold components shall not be loaded in excess of their maximum intended loads or rated capacities, whichever is less.
2. The use of shore or lean-to scaffolds is prohibited.
3. Scaffolds and scaffold components shall be inspected for visible defects by a competent person before each work shift, and after any occurrence which could affect a scaffold's structural integrity.
4. Any part of a scaffold damaged or weakened such that its strength is less than that required by paragraph 1 in Capacity of this section shall be immediately repaired or replaced, braced to meet those provisions, or removed from service until repaired and must be inspected by PE before use.
5. Scaffolds shall not be erected, used, dismantled, altered, or moved such that they or any conductive material handled on them might come close to exposed and energized power lines.

The clearance between scaffolds and power lines shall be as follows:

Line Voltage Distances		
Lines Voltage	Minimum Distance	Alternatives
Insulated		
Less than 300 volts	3 feet (0.9m)	
300 volts to 50 kv	10 feet (3.1m)	
More than 50 kv	10 feet (3.1m) plus 0.4 inches (1.0 cm) for each 1 kv over 50 kv.	2 times the length of the line insulator, but never less than 10 feet (3.1m)
Un-insulated		
Less than 50 kv	10 feet (3.1m)	
More than 50 kv	10 feet (3.1m) plus 0.4 inches (1.0cm) for each 1kv over 50 kv.	2 times the length of the line insulator, but never less than 10 feet (3.1m)

Table 19: Scaffold and Power Line Distances



Exception: Scaffolds and materials may be closer to power lines than specific above where such clearance is necessary for performance of work, and only after utility company, or electrical system operator, has been notified of the need to work closer and the utility company, or electrical system operator, has de-energized the lines, relocated the lines, or installed protective coverings to prevent accidental contact with the lines.

6. Scaffolds shall be erected, moved, dismantled, or altered only under the supervision and direction of a competent person qualified in scaffold erection, moving, dismantling or alteration. Such activities shall be performed only by experienced and trained employees selected for such work by the competent person.
7. Employees shall be prohibited from working on scaffolds covered with snow, ice, or other slippery material except as necessary for removal of such material except as necessary for removal of such materials.
8. Where swinging loads are being hoisted on to near scaffolds such that the loads might contact the scaffold, tag lines or equivalent measures to control the loads shall be used.

9. Suspension ropes shall be shielded from heat producing processes. When acids or other corrosive substances are used on a scaffold, the ropes shall be shielded, treated to protect against the corrosive substances, or shall be of a material that will not be damaged by the substance being used.
10. Work on scaffolds is prohibited during storms or high winds unless a competent person has determined that it is safe for employees to be on the scaffold and those employees are protected by a personal fall arrest system or wind screens. Wind screens shall not be used unless the scaffold is secured against the anticipated wind forces imposed.
11. Debris shall not be allowed to accumulate on platforms.
12. Makeshift devices, such as but not limited to boxes and barrels, shall not be used on top of scaffold platforms to increase the working level height of employees.
13. Ladders shall not be used on scaffolds to increase the working level height of employees, except on large area scaffolds where employers have satisfied the following criteria:
14. When the ladder is placed against a structure which is not part of the scaffold, the scaffold shall be secured against the sideways thrust exerted by the ladder;
15. The ladder legs shall be on the same platform or other means shall be provided to stabilize the ladder against unequal platform deflection, and Personal Fall Arrest System.
16. The ladder legs shall be secured to the scaffold to prevent their movement;
17. Platforms shall not deflect more than 1/60 of the span when loaded.
18. To reduce the possibility of welding current arcing through the suspension wire rope when performing welding from suspended scaffolds, the following precautions shall be taken, as applicable:
 - a. An insulated thimble shall be used to attach each suspension wire rope to its hanging support (such as cornice hook or outrigger). Excess suspension wire rope and any additional independent lines from grounding shall be insulated
 - b. The suspension wire rope shall be covered with insulating material extending at least (1.2 m) above the hoist. If there is a tail line below the hoist, it shall be insulated to prevent contact with the platform. The portion of the tail line that hangs free below the scaffold shall be guided or retained, or both, so that it does not become grounded;
 - c. Each hoist shall be covered with insulated protective covers
 - d. In addition to a work lead attachment required by the welding process, a grounding conductor shall be connected from the scaffold to the structure. The size of this conductor shall be at least the size of the welding process work lead, and this conductor shall not be in the series with the welding process or the work piece
 - e. If the scaffold grounding lead is disconnected at any time, the welding machine shall be shut off
 - f. An active welding rod or uninsulated welding lead shall not be allowed to contact the scaffold or its suspension system

FALL PROTECTION

1. Each employee on a scaffold more than six (6) feet above a lower level shall be protected from falling to that lower level shall be protected from falling to that lower level. Paragraphs 3 through 9 of this section establish the types of Fall Protection to be provided to the employees on each type of scaffold. Paragraph 10 of this section address Fall Protection for scaffold erectors and dismantlers.

2. The Fall Protection requirements for employees installing suspension scaffold support systems on floors, roofs, and other elevated surfaces are set forth in subpart Fall Protection of this part.
3. Each employee on a boatswains' chair, catenary scaffold float scaffold, needle beam scaffold, or ladder jack scaffold shall be protected by a personal fall arrest system;
4. Each employee on a single-point or two-point adjustable suspension scaffold shall be protected by both a personal fall arrest system and guardrail system;
5. Each employee on a crawling board (chicken ladder) shall be protected by a personal fall arrest system, a guardrail system (with minimum 200 pound toprail capacity) when the platform is supported by ropes;
6. Each employee on a self-contained adjustable scaffold shall be protected by a guardrail system (with minimum 200 pound toprail capacity) when the platform is supported by the frame structure, and by both a personal fall arrest system and a guardrail system (with minimum 200 pound toprail capacity) when the platform is supported by ropes;
7. Each employee on a walkway located within a scaffold shall be protected by a guardrail system (with minimum 200 pound toprail capacity installed within 9 ½ inches (24.1 cm) of and along at least one side of the walkway.
8. Each employee performing overhand bricklaying operations from a supported scaffold shall be protected from falling from all open sides and ends of the scaffold (except fall arrest system or guardrail system (with minimum 200 pound toprail capacity)).
9. For all scaffolds not otherwise specified in paragraphs 2 through 7 of this section, each employee shall be protected by the use of personal fall arrest systems or guardrail systems meeting the requirements of paragraph 16 of this section.
10. Effective September 2, 1997, the employer shall have a competent person determine the feasibility and safety of supported scaffolds. Employers are required to provide fall protection for employees erecting or dismantling supported scaffolds where the installation and use of such protection is feasible and does not create a greater hazard.
11. In addition to meeting the requirements of Fall Protection, personal fall arrest systems used on scaffolds shall be attached by lanyard to a vertical lifeline, horizontal lifeline, or scaffold structural member. Vertical lifelines shall not be used when overhead components, such as overhead protection or additional platform levels, are part of a single-point or two-point adjustable suspension scaffold.
12. When vertical lifelines are used, they shall be fastened to a fixed safe point of anchorage, shall be independent of the scaffold, and shall be protected from sharp edges and abrasion. Safe points of anchorage include structural members of buildings, but do not include standpipes, vents, other piping systems, electrical conduit, outrigger beams, or counterweights.
13. When horizontal lifelines are used, they shall be secured to two or more structural members of the scaffold, or they may be looped around both suspension and independent suspension lines (on scaffolds so equipped) above the hoist and brake attached to the end of the scaffold. Horizontal lifelines shall not be attached only to the suspension ropes.
14. When lanyards are connected to horizontal lifelines or structural members on a single-point or two-point adjustable suspension scaffold, the scaffold shall be equipped with additional independent support lines and automatic locking devices capable of stopping the fall of the scaffold in the event one or both of the suspension ropes fail. The independent support lines shall be equal in number and strength to the suspension ropes.
15. Vertical lifelines, independent support lines, and suspension ropes shall not be attached to each other, nor shall they be attached to or use the same point of anchorage, nor shall they be attached to the same point on the scaffold or personal fall arrest system.

16. Guardrail systems installed to meet the requirements of this section shall comply with Appendix A, Subpart L 29CFR 1926 to this subpart will be deemed to meet the requirements of paragraphs 16, 23, 24, and 25 of this section:
17. Guardrail systems shall be installed along all open sides and ends of platforms. Guardrail systems shall be installed before the scaffold is released for use by employees other than erection/dismantling crews.
18. The top edge height of top rails or equivalent member on supported scaffolds manufactured or placed in service after January 1, 2000 shall be installed between 38 inches (0.97m) and 45 inches (1.2m) above the platform surface. The top edge height on supported scaffolds manufactured and placed in service before January 1, 2000, and on all suspended scaffolds where both a guardrail and personal fall arrest system are required shall be between 36 inches (0.9 m) and 45 inches (1.2 m). When conditions warrant, the height of the top edge may exceed the 45-inch height, provided the guardrail system meets all other criteria of paragraph 16.
19. When midrails, screens, mesh, intermediate vertical members, solid panels, or equivalent structural members are used, they shall be installed between the top edge of the guardrail system and the scaffold platform.
20. When midrails are used, they shall be installed at a height approximately midway between the top edge of the guardrail system and the scaffold platform.
21. When screens and mesh are used, they shall extend from the top edge of the guardrail system to the scaffold platform, and along the entire opening between the supports.
22. When intermediate members (such as balusters or additional rails) are used, they shall not be more than 19 inches (48 cm) apart.
23. Each top rail or equivalent member of a guardrail system shall be capable of withstanding, without failure, a force applied in any downward or horizontal direction at any point along its top edge of at least 100 pounds (445 n) for guardrail systems installed on single-point adjustable suspension scaffolds or two-point adjustable suspension scaffolds and at least 200 pounds (890 n) for guardrail systems installed on all other scaffolds.
24. When the loads specified in paragraph 23 of this section are applied in a downward direction, the top edge shall not drop below the height above the platform surface that is prescribed in paragraph 18 of this section.
25. When wire rope clips are used on wire rope guardrail systems the following shall apply;
 - a. There shall be a minimum of three (3) wire rope clips installed, with the clips a minimum of six wire rope diameters apart.
 - b. Clips shall be installed according to the manufacturer's recommendations.
 - c. Clips shall be tightened to the manufacturer's recommendations.
26. Midrails, screens, mesh, intermediate vertical members, solid panels, and equivalent structural members of a guardrail system shall be capable of withstanding, without failure, a force applied in any downward or horizontal direction at any point along the midrail or the member of at least 75 pounds (333 n) for guardrail systems with a minimum 100 pound top rail capacity, and at least 150 pounds (666 n) for guardrail systems with a minimum 200 pound top rail capacity.
27. Suspension scaffold hoists and non-walk through stirrups may be used as end guardrails, if the space between the hoist or stirrup and the side guardrail or structure does not allow passage of an employee to the end of the scaffold.
28. Guardrails shall be surfaced to prevent injury to an employee from punctures or lacerations, and to prevent snagging of clothing.
29. The ends of all rails shall not overhang the terminal posts except when such overhang does not constitute a projection hazard to employees.

30. Steel or plastic banding shall not be used as a toprail or midrail.
31. Manila or plastic (or other synthetic) rope being used for toprails or midrails shall be inspected by a competent person as frequently as necessary to ensure that it continues to meet the strength requirements of Fall Protection of this section.

FALLING OBJECT PROTECTION

1. In addition to wearing hardhats each employee on a scaffold shall be provided with additional protection from falling hand tools, debris, and other small objects through the installation of toeboards, screens, or guardrail systems, or canopy structures that contain or deflect the falling objects. When the falling objects are too large, heavy or massive to be contained or deflected by any of the above-listed measures, the employer shall place such potential falling objects away from the edge of the surface from which they could fall and shall secure those materials as necessary to prevent their falling.
2. Where there is a danger of tools, materials, or equipment falling from a scaffold and striking employees shall not be permitted to enter the hazard area; or a toeboard shall be erected along the edge of platforms more than 10 feet (3.1 m) above lower levels for a distance sufficient to protect employees below, except on float (ship) scaffolds where an edging of $\frac{3}{4}$ x 1 $\frac{1}{2}$ inch (2 x 4 cm) wood or equivalent may be used in lieu of toeboards
3. Where tools, materials, or equipment are piled to a height higher than the top edge of the toeboard, paneling or screening extending from the toeboard or platform to the top of the guardrail shall be erected over the employees below.
4. Canopies, when used for falling object protection, shall comply with the following criteria:
 - a. Canopies shall be installed between the falling object hazard and the employees.
 - b. When canopies are used on suspension scaffolds for falling object protection, the scaffold shall be equipped with additional independent support lines equal in number to the number of points supported, and equivalent in strength to the strength of the suspension ropes.
 - c. Independent support lines and suspension ropes shall not be attached to the same points of anchorage.
5. Where used, toeboards shall be:
 - a. Capable of withstanding, without failure, a force of at least 50 pounds (222 n) applied in any downward or horizontal direction at any point along the toeboard (toeboards built in accordance with Appendix A, Subpart L 29CFR 1926 will be deemed to meet this requirement); and
 - b. At least three and one-half inches (9 cm) high from the top edge of the toeboard to the level of the walking/working surface. Toeboards shall be securely fastened in place at the outermost edge of the platform and have not more than $\frac{1}{4}$ inch (0.7 cm) clearance above the walking/working surface. Toeboards shall be solid or with openings not over one inch (2.5 cm) in the greatest dimension.
6. 61 FR 46107, Aug. 30, 1996, as corrected and amended at 61 FR 59831,59832, November 25, 1996
7. Effective Date Note: AT 61 FR 59832, November 25, 1996, paragraph 8 in Scaffold platform construction was amended and certain requirements stayed until November 25, 1997, or until further rulemaking has been completed, whichever is later.

ADDITIONAL REQUIREMENTS APPLICABLE TO SPECIFIC TYPES OF SCAFFOLDS

In addition to the applicable requirements of subpart General requirements, the following requirements apply to the specific types of scaffolds indicated. Scaffolds not specifically addressed by subpart General Requirements, such as but not limited to systems scaffolds, must meet the requirements of subpart General requirements.

TUBE AND COUPLER SCAFFOLDS

1. When platforms are being moved to the next level, the existing platform shall be left undisturbed until the new bearers have been set in place and braced prior to receiving the new platforms.
2. Transverse bracing forming an “X” across the width of the scaffold shall be installed at the scaffold ends and at least at every third set of posts horizontally (measured from only one end) and every fourth runner vertically. Bracing shall extend diagonally from the inner post or runners. Building ties shall be installed at the bearer levels between the transverse bracing and shall conform to the requirements of subpart Criteria for supported scaffolds.
3. On straight run scaffolds, longitudinal bracing across the inner and outer rows of posts shall be installed diagonally in upward to the top of the scaffold at approximately a 45 degree angle. On scaffolds whose length is less than their height, such bracing shall be installed from the base of the end posts upward to the opposite end posts, and then in alternating directions until reaching the top of the scaffold. Bracing shall be installed as close as possible to the intersection of the bearer and post or runner and post.
4. Where conditions preclude the attachment of bracing to post, bracing shall be attached to the runners as close to the post as possible.
5. Bearers shall be installed transversely between posts, and when coupled to this posts, shall have the inboard coupler bear directly on the runner coupler. When the bearers are coupled to the runners, the couplers shall be as close to the posts as possible.
6. Bearers shall extend beyond the posts and runners, and shall provide full contact with the coupler.
7. Runners shall be interlocked on straight runs to form continuous lengths, and shall be coupled to each post. The bottom runners and bearers shall be located as close to the base as possible.
8. Couplers shall be of a structural metal, such as drop-forged steel, malleable iron, or structural grade aluminum. The use of gray cast iron is prohibited.

FABRICATED FRAME SCAFFOLDS

1. When moving platforms to the next level, the existing platform shall be left undisturbed until the new end frames have been set in place and braced prior to receiving the new platforms.
2. Frames and panels shall be braced by cross, horizontal, or diagonal braces, or combination thereof, which secure vertical members together laterally. The cross braces shall be of such length as will automatically square and align vertical members so that the erected scaffold is always plumb, level, and square. All brace connections shall be secured.
3. Frames and panels shall be joined together vertically by coupling or stacking pins or equivalent means.
4. Where uplift can occur which would displace scaffold end frames or panels, the frames or panels shall be locked together vertically by pins or equivalent means.

5. Brackets used to support cantilevered loads shall:
 - a. Be seated with side-brackets parallel to the frames and end-brackets at 90 degrees to the frames
 - b. Not be bent or twisted from these positions
 - c. Be used only to support personnel, unless the scaffold has been designed for other loads by a qualified engineer and built to withstand the tipping forces caused by those other loads being placed on the bracket-supported section of the scaffold

PLASTERERS', DECORATORS', AND LARGE AREA SCAFFOLDS

Scaffolds shall be constructed in accordance with paragraphs 1 in Pole scaffolds, paragraph 1 of Tube and coupler scaffolds and in paragraph 1 in fabricated frame scaffolds of these sections as appropriate.

BRICKLAYERS' SQUARE SCAFFOLDS

1. Scaffolds made of wood shall be reinforced with gussets on both sides of each corner.
2. Diagonal braces shall be installed on all sides of each square.
3. Diagonal braces shall be installed between squares on the rear and front sides of the scaffold, and shall extend from the bottom of each square to the top of the next square.
4. Scaffolds shall not exceed three tiers in height, and shall be so constructed and arranged that one square rests directly above the other. The upper tiers shall stand on a continuous row of planks laid across the next lower tier, and shall be nailed down or otherwise secured to prevent displacement.

HORSE SCAFFOLDS

1. Horse Scaffolds are not permitted for use on any School Construction Authority Project.

FORM SCAFFOLDS AND CARPENTERS' BRACKET SCAFFOLDS

1. Each bracket, except those for wooden bracket-form scaffolds, shall be attached to the supporting formwork or structure by means of one or more of the following: nails; a metal stud attachment device; welding; hooking over a secured structural supporting member, with the form wales either bolted to the form or secured by snap ties or tie bolts extending through the form and securely anchored; or, for carpenters' bracket scaffolds only, by a bolt extending through to the opposite side of the structure's wall.
2. Wooden bracket-form scaffolds shall be an integral part of the form panel.
3. Folding type metal brackets, when extended for use, shall be either bolted or secured with a locking-type pin.

ROOF BRACKET SCAFFOLDS

1. Scaffold brackets shall be constructed to fit the pitch of the roof and shall provide a level for the platform.

2. Brackets (including those provided with pointed metal projections) shall be anchored in place by nails unless it is impractical to use nails. When nails are not used, brackets shall be secured in place with first-grade manila rope of at least three-fourth inch (1.9 cm) diameter, or equivalent. Use fall protection as required.

OUTRIGGER SCAFFOLDS

1. The inboard end of outrigger beams, measured from the fulcrum point to the extreme point of anchorage, shall be not less than one and one-half times the outboard end in length.
2. Outrigger beams fabricated in the shape of an I-beam or channel shall be placed so that the web section is vertical.
3. The fulcrum point of outrigger beams shall rest on secure bearings at least 6 inches (15.2 cm) in each horizontal dimension.
4. Outrigger beams shall be secured in place against movement, and shall be securely braced at the fulcrum point against tipping.
5. The inboard ends of outrigger beams shall be securely anchored either by means of braced struts bearing against sill ins contact with the overhead beams or ceiling, or by means of tension members secured to the floor joists underfoot, or by both.
6. The entire supporting structure shall be securely braced to prevent any horizontal movement.
7. To prevent their displacement, platform units shall be nailed, bolted, or otherwise secured to outriggers.
8. Scaffolds and scaffold components shall be designed by a registered professional engineer and shall be constructed and loaded in accordance with such design.

PUMP JACK SCAFFOLDS

1. Pump jack brackets, braces, and accessories shall be fabricated from metal plates and angles. Each pump jack bracket shall have two positive gripping mechanisms to prevent any failure or slippage.
2. Poles shall be secured to the structure by rigid triangular bracing or equivalent at the bottom, top, and other points as necessary. When the pump jack has to pass bracing already installed approximately 4 feet (1.2m) above the brace to be passed, and shall be left in place until the pump jack has been moved and the original brace reinstalled.
3. When guardrails are used for Fall Protection, a workbench may be used as the toprail only if it meets all the requirements in paragraphs 18, 23, 24, 25, and 26 of Fall Protection.
4. Work benches shall not be used as scaffold platforms.
5. When poles are made of wood, the pole lumber shall be straight-grained, free of shakes, large loose or dead knots, and other defects which might impair strength.
6. When wood poles are constructed of two continuous lengths, they shall be joined together with the seam parallel to the bracket.
7. When two by fours are spliced to make a pole, mending plates shall be installed at all splices to develop full strength of the member.

LADDER JACK SCAFFOLDS

1. Platforms shall not exceed a height of 20 feet (6.1 m).
2. All ladders used to support ladder jack scaffolds shall meet the requirements of subpart Repair bracket scaffolds of this part-Stairways and Ladders, except that job-made ladders shall not be used to support ladder jack scaffolds.
3. The ladder jack shall be so designed and constructed that it will bear on the side rails and ladder rungs or on the ladder rungs alone. If bearing on rungs only, the bearing area shall include a length of at least 10 inches (25.4 cm) on each rung.
4. Ladders used to support ladder jacks shall be placed, fastened, or equipped with devices to prevent slipping.
5. Scaffold platforms shall not be bridged one to another.

WINDOW JACK SCAFFOLDS

1. Scaffolds shall be securely attached to the window opening.
2. Scaffolds shall be used only for the purpose of working at the window opening through which the jack is placed.
3. Window jacks shall not be used to support planks placed between one window jack and another, or for other elements of scaffolding.

CRAWLING BOARDS

1. Crawling boards shall extend from the roof peak to the eaves when used in connection with roof construction, repair, or maintenance.
2. Crawling boards shall be secured to the roof by ridge hooks or by means that meet equivalent criteria (e.g. strength and durability)

STEP, PLATFORM, AND TRESTLE LADDER SCAFFOLDS

1. Scaffold platforms shall not be placed any higher than the second highest rung or step of the ladder supporting the platform.
2. All ladders used in conjunction with step, platform, and trestle ladder scaffolds shall meet the pertinent requirements of subpart Repair bracket scaffold of this part-Stairways and Ladders, except that job-made ladders shall not be used to support such scaffolds.
3. Ladders used to support step, platform, and trestle ladder scaffolds shall be placed, fastened, or equipped with devices to prevent slipping.
4. Scaffolds shall not be bridged one to another.

ADJUSTABLE SUSPENSION SCAFFOLDS

Single-Point

1. When two single-point adjustable suspension scaffolds are combined to form a two-point adjustable suspension scaffold, the resulting two-point scaffold shall comply with the requirements for two-point adjustable suspension scaffolds in paragraph 1 of Two –point adjustable suspension scaffolds (swing stages) of this section.
2. The supporting rope between the scaffold and the suspension device shall be kept vertical unless all of the following conditions are met:
 - a. The rigging has been designed by a Professional Engineer.
 - b. The scaffold is accessible to rescuers
 - c. The supporting rope is protected to ensure that it will not chafe at any point where a change in direction occurs
 - d. The scaffold is positioned so that swinging cannot bring the scaffold into contact with another surface
3. Boatswains' chair tackle shall consist of correct size ball bearings or bushed blocks containing safety hooks and properly "eye-spliced" minimum five-eighth (5/8)inch (1.6 cm) diameter first grade manila rope, or other rope which will satisfy the criteria (e.g., strength and durability, etc.) of the first grade manila rope.
4. When heat –producing process such as gas or arc welding is being conducted, boatswains' chair seat slings shall be a minimum of three-eighth (3/8) inch (1.0cm) wire rope.
5. Non-cross-laminated wood boatswains' chairs shall be reinforced on their underside by cleats securely fastened to prevent the board from splitting.

Two-Point

The following requirements do not apply to two-point adjustable suspension scaffolds used as masons' or stonemasons' scaffolds. Such scaffolds are covered by paragraph 1 of Multi-point adjustable suspension scaffolds of this section.

1. Platforms shall not be more than 36 inches (0.9 m) wide unless designed by a qualified person to prevent unstable conditions.
2. The platform shall be securely fastened to hangers (stirrups) by U-bolts or by other means which satisfy the requirements of General requirements.
3. The blocks for fiber or synthetic ropes shall consist of at least one double and one single block. The sheaves of all blocks shall fit the size of the rope used.
4. Platforms shall be of the ladder-type, plank-type, beam-type, or light-metal type. Light metal-type platforms having a rated capacity of 750 pounds or less and platforms 40 feet (12.2m) or less in length shall be tested and listed by a nationally recognized testing laboratory.

Multi-Point - Stonemasons', Scaffolds, and Masons'

1. When two or more scaffolds are used they shall not be bridged one to another unless they are designed to be bridged, the bridge connections are articulated, and the hoists are properly sized.
2. If bridges are not used, passage may be made from one platform to another only when the platforms are at the same height and are abutting.

3. Scaffolds shall be suspended from metal outriggers, brackets, wire rope slings, or means that meet equivalent criteria (e.g., strength, durability). Hooks with open ends or safety latches are prohibited.

CATENARY SCAFFOLDS

1. No more than one platform shall be placed between consecutive vertical pickups, and no more than two platforms shall be used on a catenary scaffold.
2. Platforms supported by wire ropes shall have hook-shaped stops on each end of the platforms to prevent them from slipping off the wire ropes. These hooks shall be so placed that they will prevent the platform from falling if one of the horizontal wire ropes breaks.
3. Wire ropes shall not be tightened to the extent that the application of a scaffold load will overstress them.
4. Wire ropes shall be continuous and without splices between anchors.

FLOAT SCAFFOLDS

1. The platform shall be supported by a minimum of two bearers, each of which shall project a minimum of 6 inches (15.2 cm) beyond the platform on both sides. Each bearer shall be securely fastened to the platform.
2. Rope connections shall be such that the platform cannot shift or slip.
3. When only two ropes are used with each float:
 - a. They shall be arranged so as to provide four ends which are securely fastened to overhead supports
 - b. Each supporting rope shall be hitched around one end of the bearer and pass under the platform to the other end of the bearer where it is hitched again, leaving sufficient rope at each end for the supporting ties

INTERIOR HUNG SCAFFOLDS

1. Scaffolds shall be suspended only from the roof structure or other structural member such as ceiling beams.
2. Overhead supporting members (roof structure, ceiling beams, or other structural members) shall be inspected and checked for strength before the scaffold is erected.
3. Suspension ropes and cable shall be connected to the overhead supporting members by shackles, clips, thimbles, or other means that meet equivalent criteria (e.g., strength, durability).

NEEDLE BEAM SCAFFOLDS

1. Scaffold support beams shall be installed on edge.
2. Ropes or hangers shall be used for supports, except that one end of a needle beam scaffold may be supported by a permanent structural member.
3. The ropes shall be securely attached to the needle beams.
4. The support connection shall be arranged so as to prevent the needle beam from rolling or becoming displaced.
5. Platforms units shall be securely attached to the needle beams by bolts or equivalent means. Cleats and overhang are not considered to be adequate means of attachment.

MULTI-LEVEL SUSPENDED SCAFFOLDS

1. Scaffolds shall be equipped with additional independent support lines, equal in number to the number of points supported, and of equivalent strength to the suspension ropes, and rigged to support the scaffold in the event the suspension rope(s) fail.
2. Independent support lines and suspension ropes shall not be attached to the same points of anchorage.
3. Supports for platforms shall be attached directly to the support stirrup and not to any other platform.

MOBILE SCAFFOLDS

1. Scaffolds shall be braced by cross, horizontal, or diagonal braces, or combination thereof, to prevent racking or collapse of the scaffold and to secure vertical members together laterally so as to automatically square and align the vertical members. Scaffolds shall be plumb, level, and squared. All brace connections shall be secured.
2. Scaffolds constructed of tube and coupler components shall also comply with the requirements of paragraph 1 in subpart Scaffold platform construction of this section.
3. Scaffolds constructed of fabricated frame components shall also comply with the requirements of paragraph 1 in subpart Fabricated frame scaffolds of this section.
4. Scaffolds casters and wheels shall be locked with positive wheel and/or wheel and swivel locks, or equivalent means, to prevent movement of the scaffold while the scaffold is used in a stationary manner.
5. Manual force used to move the scaffold shall be applied as close to the base as practicable, but not more than 5 feet (1.5 m) above the supporting surface.
6. Power systems used to propel mobile scaffolds shall be designed for such use. Forklifts, trucks, similar motor vehicles or add-on motors shall not be used to propel scaffolds unless the scaffold is designed for such propulsion systems.
7. Scaffolds shall be stabilized to prevent tipping during movement.
8. Employees shall not be allowed to ride on scaffolds.
9. Outrigger frames, when used, are installed on both sides of the scaffold

10. When power systems are used, the propelling force is applied directly to the wheels, and does not produce a speed in excess of 1 foot per second (.3 mps)
11. No employee is on any part of the scaffold which extends outward beyond the wheels, casters, or other supports
12. Platforms shall not extend outward beyond the base supports of the scaffold unless outrigger frames or equivalent devices are used to ensure stability.
13. Where leveling of the scaffold is necessary, screw jacks or equivalent means shall be used.
14. Caster stems and wheel stems shall be pinned or otherwise secured in scaffold legs or adjustment screws.
15. Before a scaffold is moved, each employee on the scaffold shall be made aware of the move.

REPAIR BRACKET SCAFFOLDS

1. Brackets shall be secured in place by at least one wire rope at least ½ inch (1.27 cm) in diameter.
2. Each bracket shall be attached to the securing wire rope (or ropes) by a positive locking device capable of preventing the lateral movement of the bracket.
3. Platforms shall be secured to the brackets in a manner that will prevent the separation of the platforms or the brackets on a complete scaffold.
4. When a wire rope is placed around the structure in order to provide a safe anchorage for personal fall arrest systems used by employees erecting or dismantling scaffolds, the wire rope shall meet the requirements of subpart Fall Protection of this part, but shall be at least 5/16 inch (0.8 cm) in diameter.
5. Each wire rope used for securing brackets in place or as an anchorage for personal fall arrest systems shall be protected from damage due to contact with edges, corners, protrusions, or other discontinuities of the supported structure or scaffold components.
6. Tensioning of each wire rope used for securing brackets in place shall be by means of a turnbuckle at least 1 inch (2.54 cm) in diameter, or by equivalent means.
7. Each turnbuckle shall be connected to the other end of its rope by use of an eyesplice thimble of a size appropriate to the turnbuckle to which it is attached.
8. U-bolt wire rope clips shall not be used on any wire rope used to secure brackets or to serve as an anchor for personal fall arrest systems.
9. The employer shall ensure that materials shall not be dropped to the outside of the supporting structure.

STILTS

1. Use of stilts by an employee in conjunction with, or on any type of, scaffold system is strictly prohibited on all SCA projects.
2. Stilts may be used by employees performing plastering and/or taping operations at enclosed interior locations only. Stilts may only increase height a maximum of 36 inches, without exception.
3. Surfaces on which stilts are used shall be flat and free of pits, holes and obstructions, such as debris, as well as other tripping and falling hazards.

4. Stilts shall be properly maintained. Any alteration of the original equipment shall be approved by the manufacturer

AERIAL LIFTS

Unless otherwise provided in this section, aerial lifts acquired for use on or after January 22, 1973 shall be designed and constructed in conformance with the applicable requirements of the American National Standard for "Vehicle Mounted Elevating and Rotating Work Platforms," ANSI A92,1969, including appendix. Aerial lifts acquired before January 1, 1976, unless they shall have been modified so as to conform with the applicable design and construction requirements of ANSI A92.2-1969.

Aerial lifts include the following types of vehicle-mounted aerial devices used to elevate personnel to job-sites above ground:

1. Extensible boom platforms:
2. Aerial ladders
3. Articulating boom platforms
4. Vertical towers
5. A combination of any such devices
6. Worker shall be trained

General requirements

1. Aerial equipment may be made of metal, wood, fiberglass reinforced plastic (FRP), or other material; may be powered or manually operated; and are deemed to be aerial lifts whether or not they are capable of rotating about a substantially vertical axis.
2. Aerial lifts may be "field modified" for uses other than those intended by the manufacturer provided the modification has been certified in writing by the manufacturer or by any other equivalent entity, such as a nationally recognized testing laboratory, to be in conformity with all applicable provisions of ANSI A92.2-1969 and this section and to be at least as safe as the equipment was before modification.

Specific requirements

1. Ladder trucks and tower trucks. Aerial ladders shall be secured in the lower traveling position by the locking device on top of the truck cab, and the manually operated device at the base of the ladder before the truck is moved for highway travel.
2. Extensible and articulating boom platforms. Lift controls shall be tested each day prior to use to determine that such controls are in safe working condition.
3. Only authorized persons shall operate an aerial lift.
4. Belting off to an adjacent pole, structure, or equipment while working from an aerial lift shall not be permitted.
5. Employees shall always stand firmly on the floor of the basket, and shall not sit or climb on the edge of the basket or use planks, ladders, or other devices for a work position.
6. A body belt shall be worn and lanyard attached to the boom or basket when working from an aerial lift.



Note: As of January 1, 1998, subpart Fall Protection of this part provides that body belts are not acceptable as part of a personal fall arrest system. The use of a body belt in a tethering system or in a restraint system is acceptable and is regulated under Positioning device system.

7. Boom and basket load limits specified by the manufacturer shall not be exceeded.
8. The brakes shall be set and when outriggers are used, they shall be positioned on pads or a solid surface. Wheel chocks shall be installed before using an aerial lift on an incline provided they can be safely installed.
9. An aerial lift truck shall not be moved when the boom is elevated in a working position with men in the basket, except for equipment which is specifically designed for this type of operation in accordance with the provisions of paragraphs (a)1, (e) Subpart L, 29CFR 1926.
10. Articulating boom and extensible boom platforms, primarily designed as personnel carriers, shall have both platform (upper) and lower controls. Upper controls shall be in or beside the platform within easy reach of the operator. Lower controls shall provide for overriding the upper controls. Controls shall be plainly marked as to their function. Lower level controls shall not be operated unless permission has been obtained from the employee in the lift, except in case of emergency.
11. Climbers shall not be worn while performing work from an aerial lift.
12. The insulated portion of an aerial lift for travel, the boom(s) shall be inspected to see that it is properly cradled and outriggers are in stowed position except as provided in paragraph 9 of this section.
13. Electrical tests. All electrical tests shall conform to the requirements of ANSI A92.2-1969 section 5. However equivalent DC voltage tests may be used in lieu of the AC voltage specified in A92.2-1969; DC voltage tests which are approved by the equipment manufacturer or equivalent entity shall be considered an equivalent test for the purpose of this paragraph 13.
14. Bursting safety factor. The provisions of the American National Standards Institute standard ANSI A92.2-1969, section 4.9 Bursting Safety Factor shall apply to all critical hydraulic and pneumatic components. Critical components are those in which a failure would result in a free fall or free rotation of the boom. All non-critical components shall have a bursting safety factor of a least 2 to 1.
15. Welding standards. All welding shall conform to the following standards a applicable:
16. Standard Qualification Procedure, AWS B3.0-41.
17. Specifications for Welding Highway and Railway Bridges, AWS D,0-69.

Training Requirements

This section supplements and clarifies the requirements of paragraph 9 as these relate to the hazards of work on scaffolds.

1. The Contractor shall have each employee who performs work while on a scaffold trained by a person qualified in the subject matter to recognize the hazards associated with the type of scaffold being used and to understand the procedures to control or minimize those hazards. This training will meet the requirements of Local Law 52-05 where required. The training shall include the following areas, as applicable:
2. The nature of any electrical hazards, fall hazards and falling object hazards in the work area; if system is within 15' within power lines then must removed or have utility
3. The correct procedures for dealing with electrical hazards and for erecting, maintaining, and disassembling the Fall Protection systems and falling object protection systems being used;

4. The proper use of scaffold, and the proper handling of materials on the scaffold;
5. The maximum intended load and the load-carrying capacities of the scaffolds used; and
6. Any other pertinent requirements of this subpart.
7. The Contractor shall have each employee who is involved in erecting, disassembling, moving, operating, repairing, inspecting, and maintaining the type of scaffold be trained in accordance with NYC DOB ;
8. The design criteria, maximum intended load-carrying capacity and intended use of the scaffold;
9. Any other pertinent requirements of this subpart.
10. When the employer has reason to believe that an employee lacks the skill or understanding needed for safe work involving the erection, use or dismantling of scaffolds, the employer shall retain each such employee so that the requisite proficiency is regained. Retraining is required in at least the following situations:
 - a. Where changes at the worksite present a hazard about an employee has not been previously trained
 - b. Where changes in types of scaffolds, Fall Protection, falling object protection, or other equipment present a hazard about which an employee has not been previously trained
 - c. Where inadequacies in an affected employee's work involving scaffolds indicate that the employee has not retained the requisite proficiency.
 - d. At the request of the SCA safety Officer

Part 15 Appendix A

Drawings and Illustrations

INTRODUCTION

This Appendix provides drawings of particular types of scaffolds and scaffold components, and graphic illustrations of bracing patterns and tie spacing patterns.

This Appendix is intended to provide visual guidance to assist the user in complying with the requirements of this part.

Figure 30: Bracing - Tube and Coupler Scaffolds

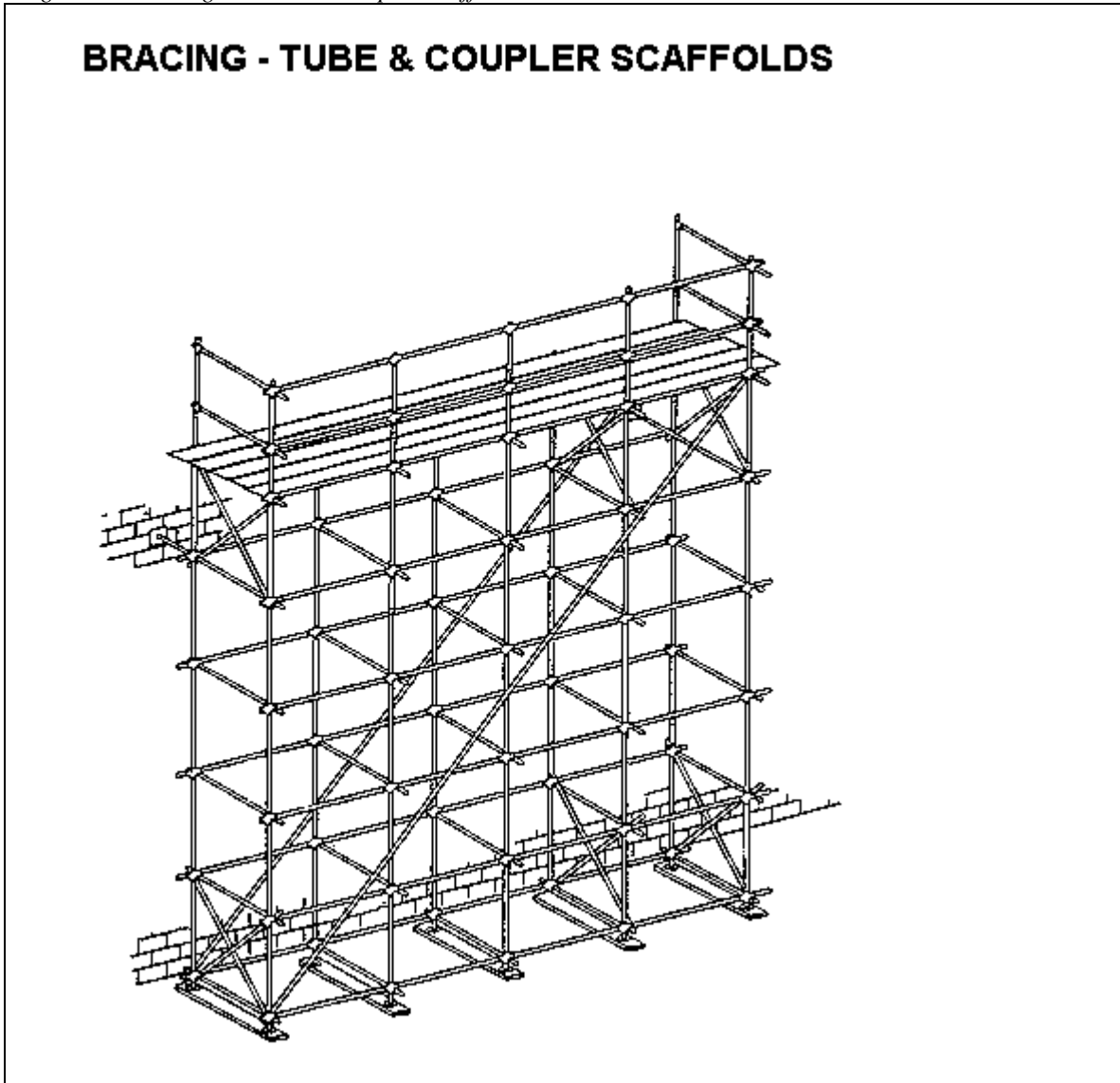

Figure 31: Suspended Scaffold Platform Welding Precautions

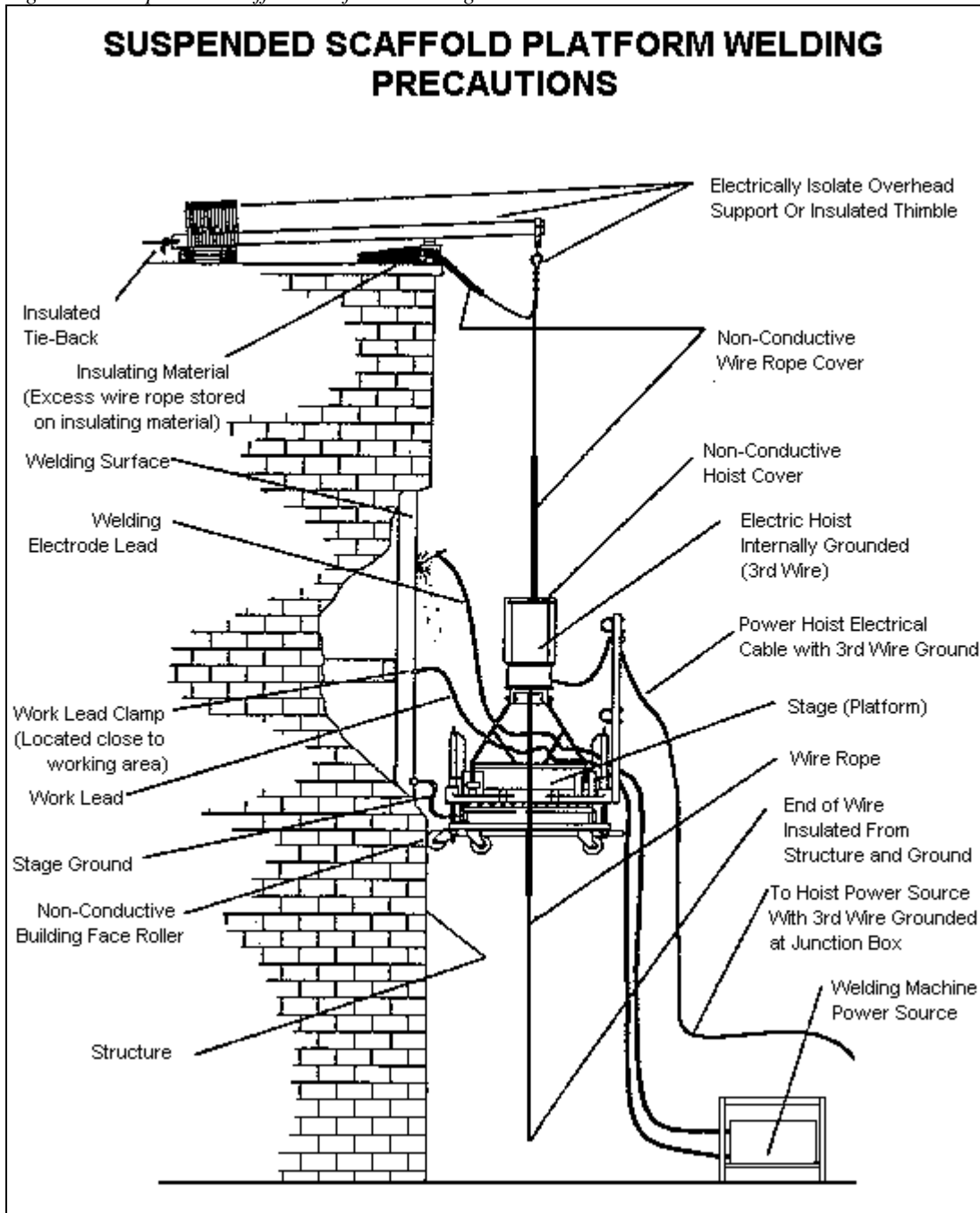
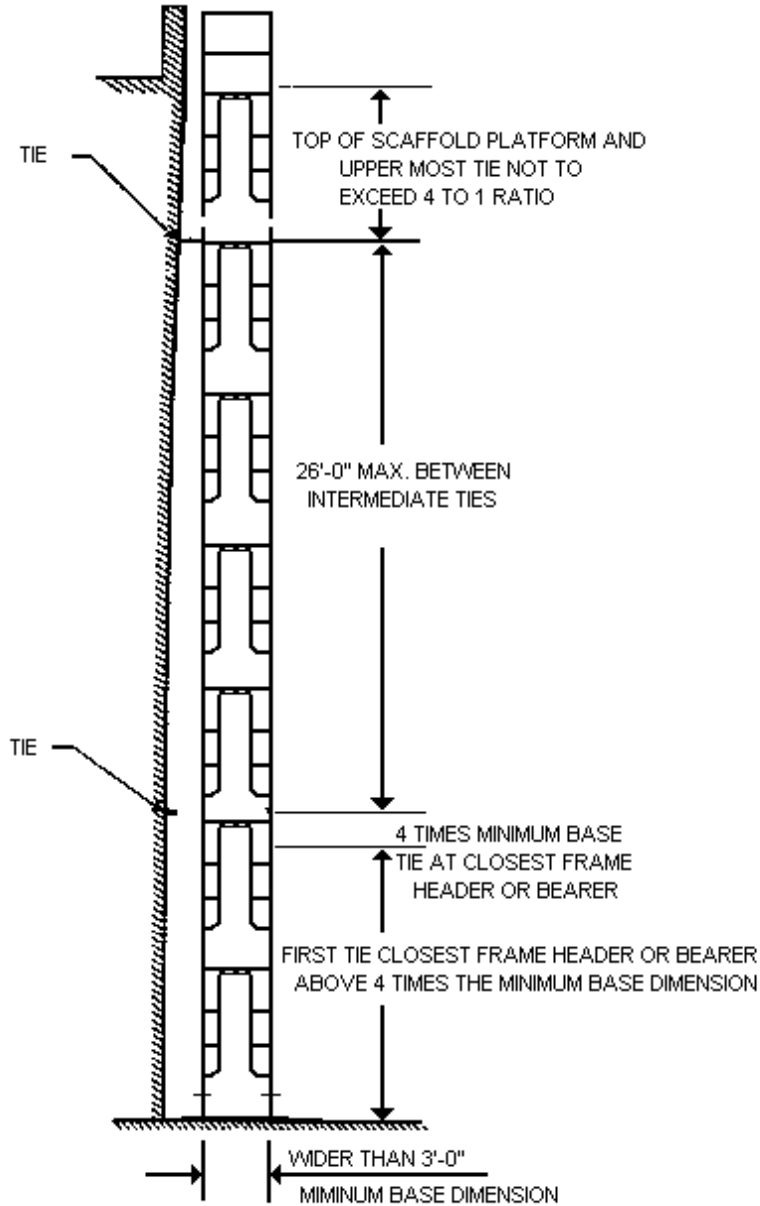

Figure 32: Maximum Vertical Tie Spacing Wider Than 3'-0" Bases

MAXIMUM VERTICAL TIE SPACING WIDER THAN 3'-0" BASES



DRAWING TO SHOW TYPE OF CONSTRUCTION AND POSITIVE ANCHORAGE TO BACK UP SUBSTRATE.

Figure 33: Maximum Vertical Tie Spacing 3'0" and Narrower Bases

MAXIMUM VERTICAL TIE SPACING 3'-0" AND NARROWER BASES

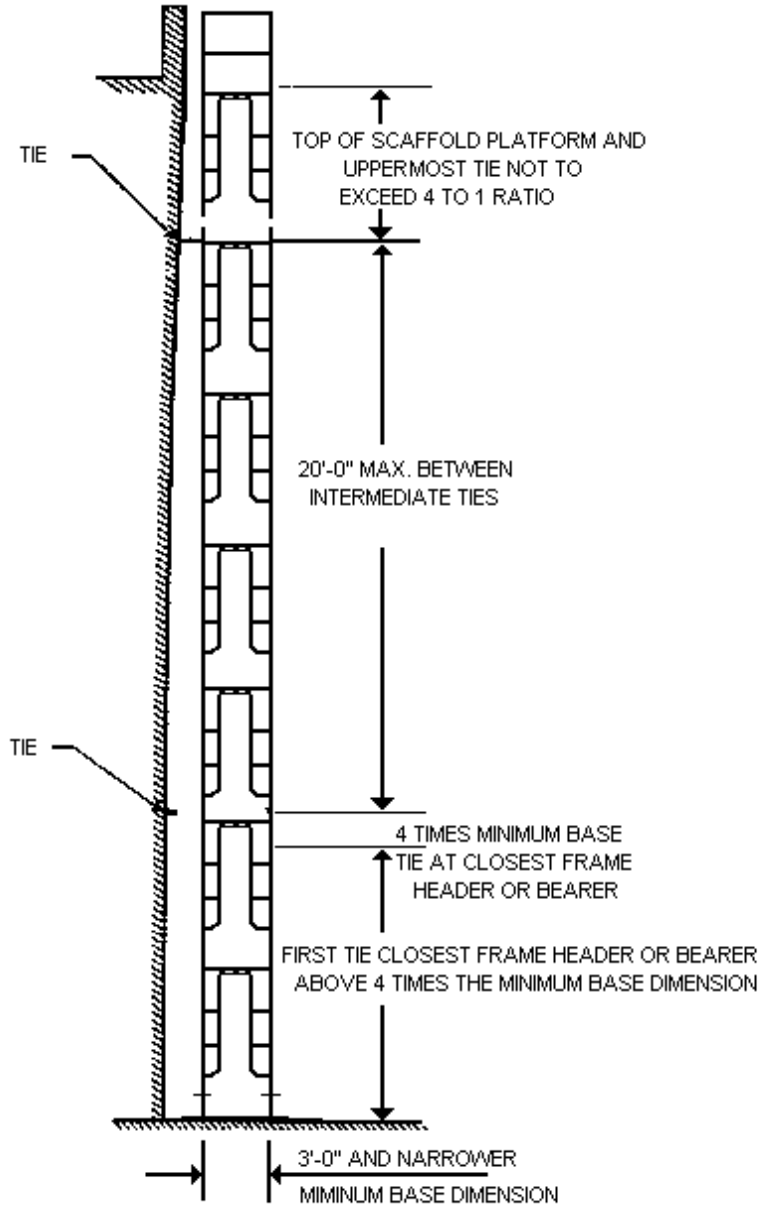

Figure 34: System Scaffold

SYSTEM SCAFFOLD

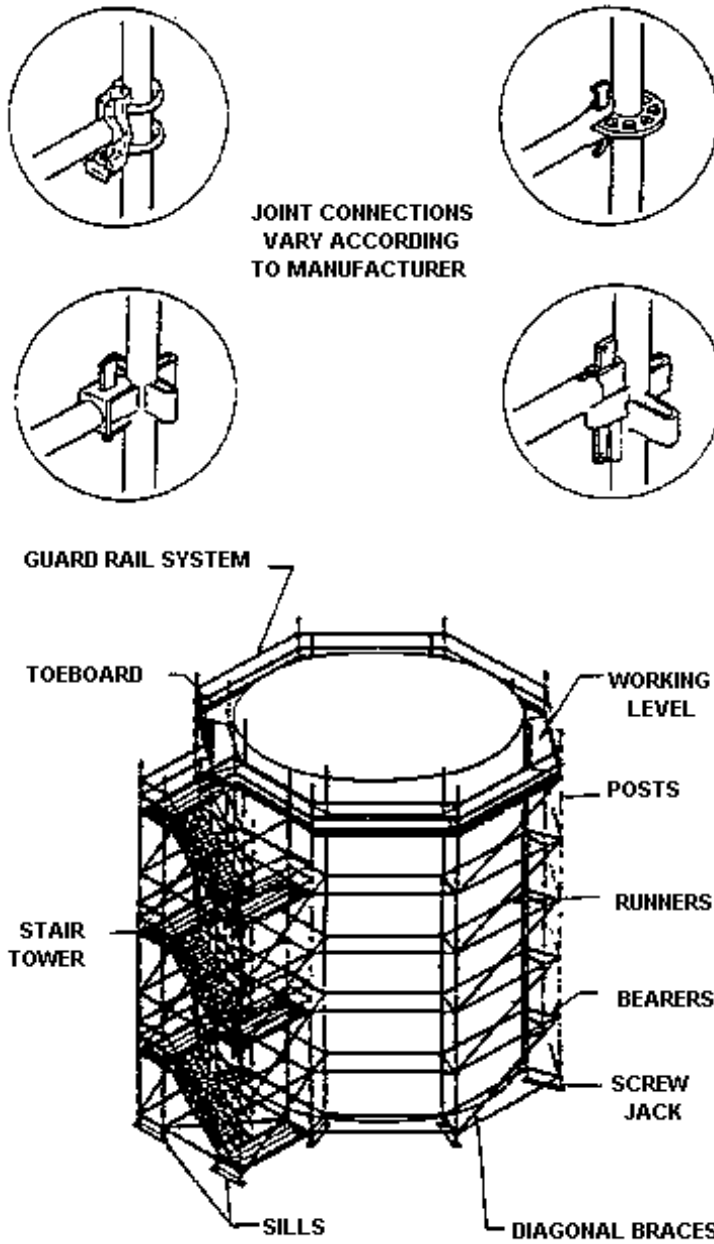
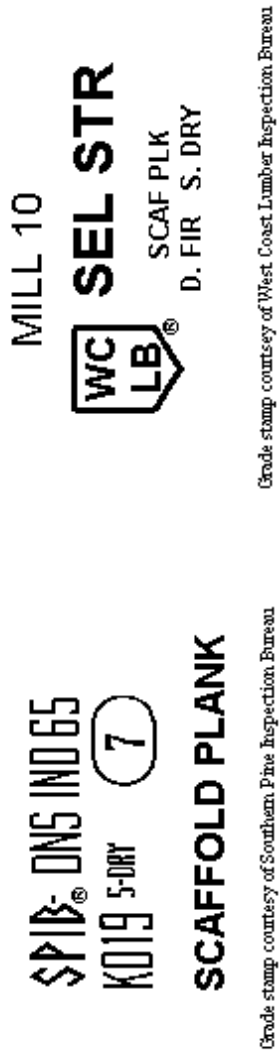

Figure 35: Example Scaffold Inspection



METHOD OF PLANK INSPECTION BEFORE ERECTION

Figure 36: Tube and Coupler Scaffold

TUBE and COUPLER SCAFFOLD

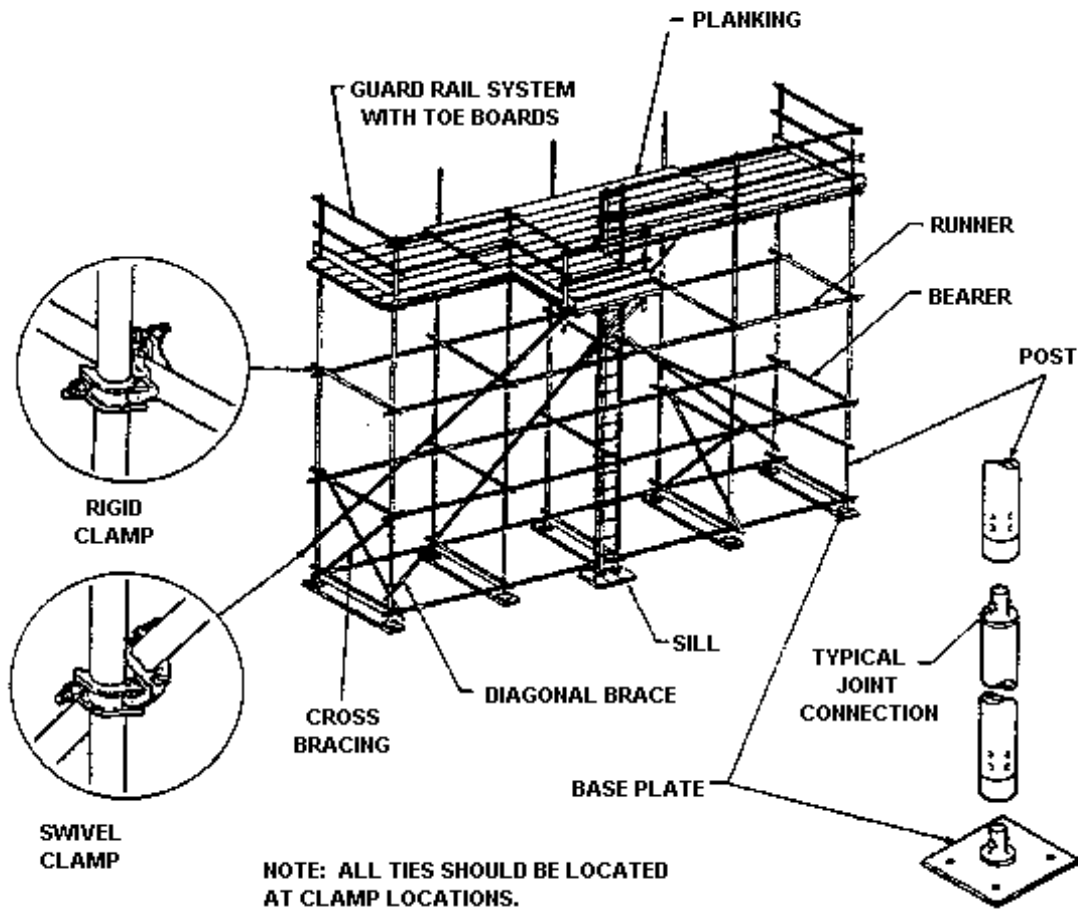
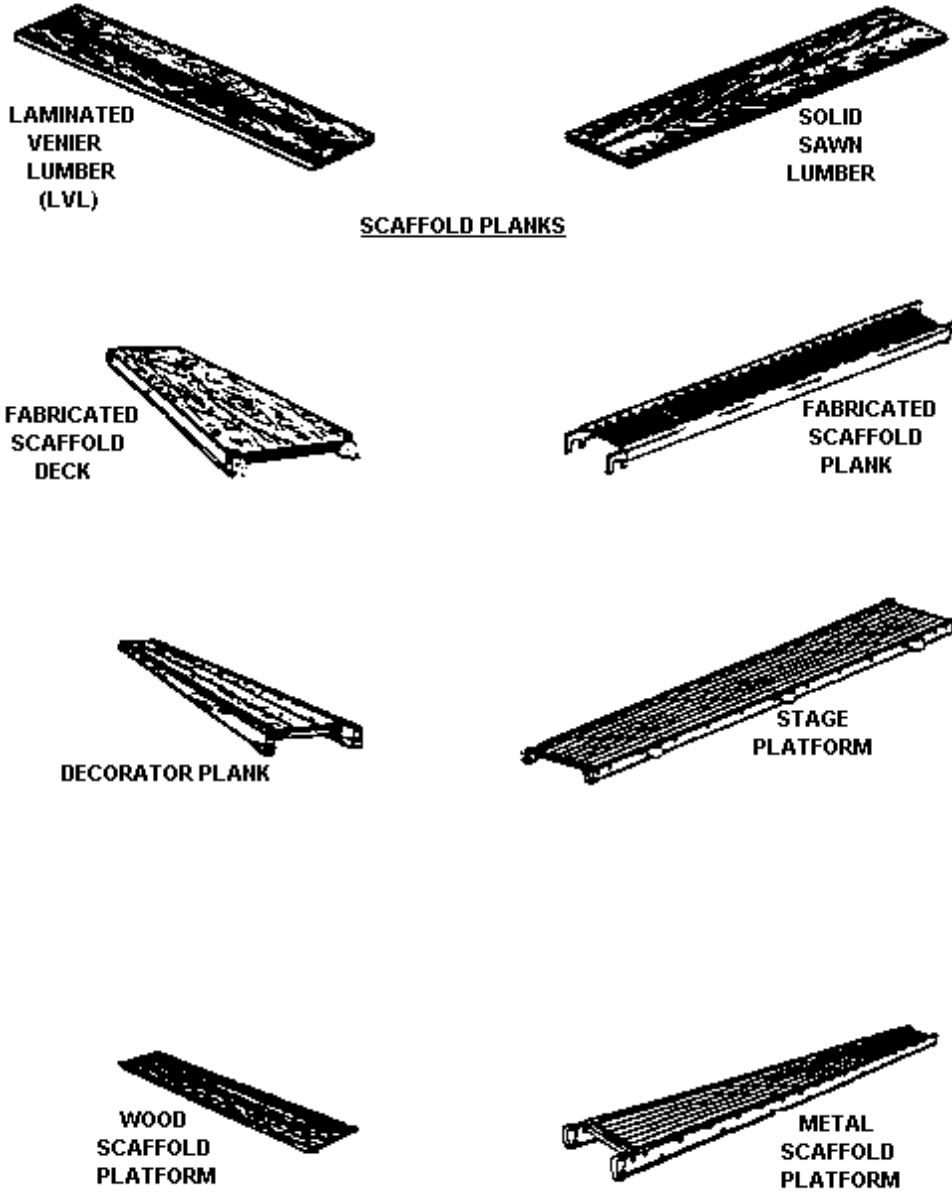

Figure 37: Scaffolding Work Surfaces

SCAFFOLDING WORK SURFACES



Part 15 Appendix B

Licensed Master or Special Rigger Responsibilities

APPLICABILITY

In accordance with Chapter 1 article 404 Administrative Code, all rigging work, other than work exempted under section 28-404.1 of such code, must be performed by or under the supervision of a licensed special or master rigger. The rules in this section set forth the specific supervisory responsibilities of a licensed special or master rigger.

BASIC TERMINOLOGY

Critical Picks; See Rigging Foreman

PLANNING

Except as otherwise specifically provided in subdivision “Specialty Crew” of this section, the licensee must personally plan the equipment set-up and operation of all rigging operations. This responsibility may not be delegated.

SUPERVISION OF RIGGING OPERATIONS OTHER THAN CRITICAL PICKS

Except as otherwise provided in subdivision “Supervision of Critical Picks” of this section, a licensee need not be personally on site during rigging operations provided that a rigging foreman designated by the licensee pursuant to subdivision “Designation of a Rigging Foreman” of this section is continuously on site and he/she performs or manages the work under the off site supervision of the licensee as follows:

1. The licensee and the rigging foreman at the work site are in frequent and direct contact with each other during the course of the rigging operation.
2. For work involving the use of cranes, derricks, work platforms, suspension scaffolds, or other rigging setup where the safe founding or support of such equipment is a cause of concern (i.e. over sidewalks, roadways, or yards where vaults or other sub surfaces structures exist; or where hooks

or clamps are used on parapet walls to support hanging scaffolds, etc.) the licensee personally visits the work site to inspect and approve the rigging equipment founding and setup prior to commencement of rigging operations and each time the founding or support changes.

3. The licensee is readily available to provide onsite supervision should need arise.
4. The rigging foreman has in his/her possession at the work site the “Certificate of License Record” of the licensee (tear-off) issued by the Department, which shall be presented upon the demand of any enforcement officer.

SUPERVISION OF CRITICAL PICKS

The licensee must be continuously on site during critical picks and must personally perform or personally supervise all critical picks. Off site supervision of critical picks is not permitted.

RIGGING CREW

Except as otherwise provided in sub subdivision “Specialty Crew” of this section, all members of the rigging crew must be employees on the payroll of such licensee or where the license is used by the holder thereof for or on behalf of a partnership, corporation or other business association as provided for in section 28-401.17 of the Administrative Code such members must be employees of the payroll of such partnership, corporation or business association.

SPECIALTY CREW

Except as otherwise provided in this subdivision, and except as provided for in section 28-401.17 of the Administrative Code, the licensee or rigging foreman designated by a licensee may not perform or supervise rigging work for another person, corporation, partnership or business association. Where rigging work is best handled by or requires crews of a specialty trade (e.g. handling hazardous materials or chemicals such as asbestos, or climbing, erecting or dismantling tower cranes) the licensee or a rigging foreman designated by such licensee may perform or supervise work on behalf of a person, partnership, corporation or business association engaged in such specialty trade, subject to the following conditions:

1. The Cranes and Derricks Division of the department must approve the licensee’s written request for such proposed rigging operation.
2. The licensee must either plan the equipment setup and operation or be an active participant of the planning team
3. For loads of one thousand two hundred pounds or more and for all critical picks, the licensee must provide continuous on site personal supervision to the rigging crew
4. For loads below one thousand two hundred pounds which are not critical picks, the licensee need not be on site if a rigging foreman designated by such licensee is continuously on site he or she manages the work under the off site supervision of the licensee in accordance with the condition set forth in items (1), (2), (3), and (4) of subdivision “Supervision of Rigging Operations Other Than Critical Picks” of this section.
5. The licensee or his/her designated rigging foreman must have full authority to examine rigging hardware, to approve rigging setups, to mandate changes and to stop the job
6. The licensee is responsible for all aspects of rigging safety on the job

7. The licensee shall confirm that members of the specialty crew are insured to the minimum requirements specified in section 28-401.9 of the code and are covered by worker's compensation by the specialty crew's employer

QUALIFICATIONS FOR DESIGNATION AS A RIGGING FOREMAN

An individual designated as a rigging foreman by a licensed special or master rigger shall:

1. Be an employee on the payroll and covered by the worker's compensation insurance of the licensee or the business association of the licensee
2. Be at least 18 years of age
3. Be able to read and write English
4. Be able to identify critical picks
5. Be familiar with the relevant sections of the Building Code, OSHA safety standards and industry safety practices
6. Have been trained to react properly to mechanical malfunctions or adverse weather
7. Be able to evaluate the fitness of the rigging crew, including, where applicable, the issuance of a certificate of fitness pursuant to section 13-03 of this chapter.

An individual designated as a rigging foreman by a licensed special rigger shall, in addition to the qualifications set forth in paragraph one of this subdivision, have the following additional qualifications:

1. Have at least 1 year's practical experience in the hoisting and rigging business
2. Be able to explain the risks incident to such business and precautions to be taken in connection therewith

An individual designated as a rigging foreman by a licensed master rigger shall, in addition to the qualification set forth in paragraph one of this subdivision, have the following additional qualifications:

1. Have at least 5 years practical experience in the hoisting and rigging business
2. Be knowledgeable about and be able to explain the risks incident to the following, where applicable to the particular job:
 - a. Rigging operations and precautions to be taken in connection therewith
 - b. Safe loads and computation thereof
 - c. Types and methods of rigging
 - d. Pertinent hardware such as ropes, cables, blocks, poles, derricks, sheerlegs, and other tools used in connection with rigging operations.

DESIGNATION OF A RIGGING FOREMAN

Designation shall consist of the filing of written notification with the Department's Licensing Division of the following information:

1. A list of all rigging foreman employed by the licensee or the business association of the licensee. Each rigging foreman's full name, home address, and home phone number shall be included on the list.

2. The notification shall be signed by the licensee, shall contain his or her license number and shall be on the business letterhead of the licensee or of the business association of the licensee. The notification shall contain a representation by the licensee that all of the rigging foremen designated by him/her have the qualifications specified in previous subdivision of this section.
3. The list must be updated within two weeks of any change in the reported information relating to designated individuals or within two weeks of the termination of a designation by the filing of a new notification listing all rigging foreman designated by the licensee. The new notification shall contain the information set forth in items (1) and (2) above. The new list will supersede any earlier filed notification.

PHOTO IDENTIFICATION CARD

The licensee shall issue a photo identification card (see Exhibit 1) to each rigging foreman designated by him or her with the licensee's signature affixed thereto. Such card shall be carried by the rigging foreman at all times while he/she is engaged in any of the duties requiring such designation and shall be presented upon the demand of any authorized enforcement officer. It shall be the responsibility of the licensee to retrieve the identification card when such designation is terminated. A designation shall be terminated by the licensee if (1) the person leaves the employ of the licensee or business association of the licensee, (2) the licensee finds that the designee is not competently performing his/her duties, or (3) the licensee finds that the designee has acted in an unsafe or irresponsible manner in performing his/her duties.

RESPONSIBILITY

The designation of one or more rigging foreman shall not affect the licensee's or business association's responsibility or liability for all aspects of rigging safety including but not limited to the actions of rigging foreman, rigging crews and specialty crews, if any.

FAILURE TO COMPLY WITH RULES

If these rules are not complied with the Department may order that rigging operations stop, commence disciplinary action against the licensee or commence proceedings for the imposition of fines or civil penalties.

Part 15 Appendix C: Supervisory Responsibilities

APPLICABILITY

In accordance with section 28.415.1 of the Administrative Code, all sign hanging work, other than work exempted under section 28-415 of such code, must be performed by or under the supervision of a licensed sign hanger. The rules in this section set forth the specific supervisory responsibilities of a licensed special or master sign hanger.

PLANNING

The licensee must personally plan the equipment setup and operation of all sign hanging operations. This responsibility may not be delegated.

SUPERVISION OF SIGN HANGING OPERATIONS OTHER THAN CRITICAL PICKS

Except as otherwise provided in subdivision “Supervision of Critical Picks” of this section, a licensee need not be personally on site during in sign hanging operations provided that a sign hanging foreman designated by the licensee pursuant to the subdivision “Designation of a Sign Hanging Foreman” of this section is continuously on site and he/she performs or manages the work under the off site supervision of the licensee as follows:

1. The licensee and the sign hanging foreman at the work site are in frequent and direct contact with each other during the course of the sign hanging operation.
2. For work involving the use of cranes, derricks, work platforms, suspension scaffolds, or other rigging setup where the safe founding or support of such equipment is a cause of concern (i.e. over sidewalks, roadways, or yards where vaults or other sub surfaces structures exist; or where hooks or clamps are used on parapet walls to support hanging scaffolds, etc.) the licensee personally visits the work site to inspect and approve the rigging equipment founding and setup prior to commencement of rigging operations and each time the founding or support changes.
3. The licensee is readily available to provide onsite supervision should need arise.
4. The sign hanging foreman has in his/her possession at the work site the “Certificate of License Record” of the licensee (tear-off) issued by the Department, which shall be presented upon the demand of any enforcement officer.

SUPERVISION OF CRITICAL PICKS

The licensee must be continuously on site during critical picks and must personally perform or personally supervise all critical picks. Off site supervision of critical picks is not permitted.

SIGN HANGING CREW

All members of the sign hanging crew must be employees on the payroll of such licensee or where the license is used by the holder thereof for or on behalf of a partnership, corporation or other business association as provided for in section 26-138(b) of the Administrative Code such members must be employees of the payroll of such partnership, corporation or business association. Except as provided for in section 26-138(b) of the Administrative Code, the licensee or sign hanging foreman designated by a licensee may not perform or supervise sign hanging work for another person, corporation, partnership or business association.

QUALIFICATIONS FOR DESIGNATION AS A SIGN HANGING FOREMAN

An individual designated as a sign hanging foreman by a licensed special or master sign hanger shall:

1. Be an employee on the payroll and covered by the worker's compensation insurance of the licensee or the business association of the licensee
2. Be at least 18 years of age
3. Be able to read and write English
4. Be able to identify critical picks
5. Be familiar with the relevant sections of the Building Code, OSHA safety standards and industry safety practices
6. Have been trained to react properly to mechanical malfunctions or adverse weather
7. Be able to evaluate the fitness of the sign hanging crew, including, where applicable, the issuance of a certificate of fitness pursuant to section 9-03 of this chapter
8. Be able to read plans and specifications relating to sign construction and erection, including supporting framework and other supports
9. Have a knowledge of the problems and practices of sign constructions and hanging
10. Be familiar with the equipment and tools used in sign installations

An individual designated as a sign hanging foreman by a licensed special sign hanger shall, in addition to the qualifications set forth in paragraph one of this subdivision, have at least 3 years practical experience in sign hanging work.

An individual designated as a sign hanging foreman by a licensed master sign hanger shall, in addition to the qualifications set forth in paragraph one of this subdivision, have at least 5 years practical experience in sign hanging work.

DESIGNATION OF A SIGN HANGING FOREMAN

Designation shall consist of the filing of written notification with the Department's Licensing Division of the following information:

1. A list of all sign hanging foreman employed by the licensee or by the business association of the licensee. Each sign hanging foreman's full name, home address, and home phone number shall be included on the list.
2. The notification shall be signed by the licensee, shall contain his or her license number and shall be on the business letterhead of the licensee or of the business association of the licensee. The notification shall contain a representation by the licensee that all of the sign hanging foremen designated by him/her have the qualifications specified in the previous subdivision of this section.
3. The list must be updated within two weeks of any change in the reported information relating to designated individuals or within two weeks of the termination of a designation by the filing of a new notification listing all sign hanging foreman designated by the licensee. The new notification shall be filed in the manner and shall contain the information set forth in items (1) and (2) above. The new list will supersede any earlier filed notification.

PHOTO IDENTIFICATION CARD

The licensee shall issue a photo identification card (see Exhibit 1) to each individual designated by him or her as a sign hanging foreman with the licensee's signature affixed thereto. Such card shall be carried by the sign hanging foreman at all times while he/she is engaged in any of the duties requiring such designation and shall be presented upon the demand of any authorized enforcement officer of the city. It shall be the responsibility of the licensee to retrieve the identification card when such designation is terminated. A designation shall be terminated by the licensee if (1) the person leaves the employ of the licensee or business association of the licensee, (2) the licensee finds that the designee is not competently performing his/her duties, or (3) the licensee finds that the designee has acted in an unsafe or irresponsible manner in performing his/her duties.

RESPONSIBILITY

The designation of one or more sign hanging foreman shall not affect the licensee's or business association's responsibility or liability for all aspects of sign hanging safety including but not limited to the actions of sign hanging foreman and sign hanging crews.

FAILURE TO COMPLY WITH RULES

If these rules are not complied with the Department may order that sign hanging operations stop, commence disciplinary action against the licensee or commence proceedings for the imposition of fines or civil penalties.

Part 15 Appendix D: Requirements Operating Suspension Scaffolds

APPLICABILITY

In accordance with section 28-404.1 of the Administrative Code and Chapter 33 “Safeguards During Construction and Demolition” The rules in this section establish minimum requirements for all individuals working on or operating suspension scaffolds, either performing construction or alteration work pursuant to a permit issued by the Department, or performing rigging or sign hanging work under the supervision of a licensed master or special rigger or a master or special sign hanger.

MINIMUM REQUIREMENTS

Only the following individuals may work on or operate a suspension scaffold:

1. Where work is performed either by or under the supervision of a licensed rigger or sign hanger, the following persons may work on or operate a suspension scaffold:
 - a. A licensed master or special rigger
 - b. A licensed master or special sign hanger
 - c. A rigging or sign hanging foreman as described in 13-01 and 13-02
 - d. A rigging or sign hanging crew member issued a certificate of fitness by licensed rigger or sign hanger or his/her designated rigging or sign hanging foreman.
2. Where construction or alteration work is performed pursuant to a permit issued by the Department and, in accordance with 28-105.1 of the Administrative Code, such work is not performed by or under the supervision of a licensed rigger or sign hanger, the following persons may work on or operate a suspension scaffold:
 - a. A person who holds a certificate of completion from a recognized scaffold safety training course as set forth in subdivision “Recognized Scaffold Safety Training Courses” and subdivision “Certificate of Completion” of this section
 - b. An apprentice in recognized program, as set forth in subdivision “Recognized Scaffold Apprenticeship Program” of this section, NOT TO BE REPLACED BY THE PROPER TRAINING CARD.

- c. A person who holds a challenge examination certificate from a recognized administrator of challenge examinations, as set forth in subdivision “Challenge Examination and Certificate Examination Certificate” issued prior to April 1st 2008 of this section.

In accordance with 27-1045, it shall be the responsibility of the superintendent of construction to ensure that any person working on or operating a suspension scaffold on the job site has the necessary certificate of completion or challenge examination certificate or is enrolled in a recognized apprenticeship program. The superintendent of construction must maintain written records to such effect.

3. In addition to those persons listed in “Minimum Requirements” (1) and (2) above, a registered architect or professional engineer who is familiar with rigging hardware, rigging equipment setup and operation, pertinent Building Code provisions, Federal OSHA and State safety standards, emergency procedures, and recommended industry safe work practices may work on or operate a suspension scaffold, provided, however, that a registered architect or professional engineer not familiar with such codes, standards procedures and practices may ride on a scaffold to perform inspections so long as the architect or engineer does not perform work from or operate the scaffold.

CERTIFICATE OF FITNESS

Minimum Requirements

A person issued a certificate of fitness must:

1. Be found capable of performing the scaffold work in a safe and responsible manner by the issuer at the time of issuance
2. Be able to communicate without difficulty with the supervising licensed rigger, licensed sign hanger, rigging or sign hanging foreman, or superintendent of construction on site, and either
3. Possess a certificate of completion from a recognized scaffold safety training course in accordance with subdivision “Recognized Scaffold Safety Training Courses” and subdivision “Certificate of Completion” of this section
4. Be enrolled in a recognized scaffold apprenticeship program in accordance with subdivision “Recognized Apprenticeship Program” of this section
5. Possess a challenge examination certificate in accordance with subdivision “Challenge Examination and Certificate Examination Certificate” issued prior to April 1 2008 of this section

Persons Authorized to Issue a Certificate of Fitness

The following persons may issue a certificate of fitness:

1. A licensed master or special rigger
2. A licensed master or special sign hanger
3. A rigging or sign hanging foreman designated pursuant to sections or 13-02 if these rules, as agent of the licensee

Duty of Licensee to Ensure Compliance

It shall be the sole responsibility of the licensee who issues the certificate of fitness, either personally or through a designated foreman, to ensure that the individual who receives the certificate meets the requirements of above subdivision “Minimum Requirements” (1) of this section for the particular job. It

shall be the licensee's responsibility to maintain written records and copies relating to whom and when certificates were issued, as well as each certificate holder's certificate of completion from a recognized scaffold safety training course or apprentice program or challenge examination certificate, which substantiates the individual's fitness. If a person issued a certificate of fitness is later found to be unqualified or to have failed to work on a suspension scaffold in a safe and workmanlike manner, it shall be the licensee's responsibility to rescind the certificate of fitness and to remove the subject person from the job.

Certificate of Fitness

The certificate of fitness must include the name of the holder, the date of the issuance, the name, and license number of the license, the name, address, and telephone number of the company, and the signature of the issuer.

1. Job-specific certificate of fitness for crew members employed only for a particular job or jobs, The certificate of fitness must contain the job location for which such certificate is valid as well as the duration of the job (see exhibit 2). Such certificate of fitness, as well as a photo identification of the certificate holder acceptable to the Department, must be available on site for inspection.
2. Certificate of fitness for regular members of the licensee's rigging or sign hanging crew. Notwithstanding the provisions of paragraph 1) of this section, at the option of the issuer, a permanent non job-specific photo identification or certificate of fitness may be issued to regular members of the licensee's or of the licensee's business association's rigging or sign hanging crews.

RECOGNIZED SCAFFOLD SAFETY TRAINING COURSES AND APPRENTICESHIP PROGRAMS

Recognized Scaffold Safety Training Courses

Any organization (e.g. private, governmental, non-profit, or trade union) or institute may apply to the Department for recognition of its scaffold safety training course. Such application shall be made to the Department's Cranes and Derricks Division and shall include: instructors' qualifications, curriculum, teaching schedule, and materials used. The training course must include a significant field component, including instruction in rigging hardware (e.g. ropes, blocks, motors, scaffolds, controls, etc.), methods (e.g. reeving, suspension, startup procedures, netting, etc.), and applicable laws (NYC Building Codes and rules, OSHA standards, etc.). The Department may participate in or observe any training course without prior notification, and reserves the right to rescind recognition. The Department shall inform or approve a recognized course in writing, and shall maintain a list of approved training course. Any organization or institute that offers the recognized scaffold safety training course must also offer a challenge examination outlined in subdivision "Challenge Examination and Certificate Examination Certificate" of this section, either free or at a nominal cost to all applicants.

Recognized Apprenticeship Program

Any organization (e.g. private, government, non-profit, trade union) may apply to the Department of recognition of its scaffold safety training apprenticeship program. The requirements for recognition are the same as for a recognized scaffold safety training course as set forth in subdivision “Recognized Scaffold Safety Training Courses” of this section.

Certificate of Completion

The organization providing a recognized scaffold safety training course or apprenticeship program may issue identification cards or certificates of completion to individuals who successfully complete the recognized course program. The certificate of completion issued must include the name and address of the issuing organization, the date of issuance, and the name of the recipient, and must state “NYC DOB Recognized Scaffold Safety Training Course” or “Apprenticeship Program.” Such certificate must be signed by the course administrator.

Challenge Examination and Certificate Examination Certificate

The challenge examination shall be administered by organizations or institutes that conduct a recognized scaffold safety training course or recognized apprenticeship program. The challenge examination shall consist of written and hands-on tests that enable successful candidates to demonstrate a minimum level of knowledge and skills equivalent to graduates of a recognized scaffold safety training course or apprenticeship program. A person passing the challenge examination shall be issued a challenge examination certificate by the course or examination administrator. This challenge examination certificate shall be the equivalent to the certificate of completion and shall consist of similar data, format and signature as set forth in subdivision “Certificate of Completion” of this section. Written and hands-on test for the challenge examination shall be submitted to and pre-approved in writing by the Department of Buildings, Cranes and Derricks Division. The Cranes and Derricks Division reserves the right to monitor the test to ensure its quality and fairness, and to revoke any approval if guidelines are not adhered to. Organizations or institutes that offer recognized scaffold safety training or apprenticeship programs in English or in any other language must offer an equivalent challenge examination in the appropriate language to any applicant regardless of his/her gender, race, national origin, organization or union membership, religion, or creed.

COMPLIANCE

Failure to comply with the above rules, including but not limited to any person working on a suspension scaffold unable to produce either a valid certificate of fitness or, where applicable, a certificate of completion or a challenge examination certificate and a photo identification card, any result in the Department’s ordering all work stopped, issuing violations, and commencing disciplinary action against the licensee, or commencing proceedings for the imposition of fines or civil penalties.

Part 15 Checklist: Daily Supported Scaffold Inspection Version 1

Date _____

Daily Supported Scaffold Inspection

Inspection by _____

Item Inspected	Yes	No	N/A	Comments
1. Baseplates and mudsills are in good condition and have been provided to stabilize the scaffold.				
2. All cross bracing has been installed on the frames.				
3. The connecting pins are in place to secure the scaffold frames together.				
4. An access ladder, built-on ladder or stair tower has been provided for safe access to the scaffold.				
5. Guardrails have been provided on all sides of the scaffold.				
6. Toeboards have been provided.				
7. The scaffold has been tied into the structure at proper intervals. (26 feet vertically, 30 feet horizontally after the height is 4X the base.)				
8. The anchors and ties comply with the design.				
9. Work platforms have been fully planked.				
10. Scaffolds 75 feet or more in height have been provided with a design drawing. The installation complies with the design.				
11. The scaffold frames have not been overloaded with debris, material or work platforms contrary to the design of the scaffold.				
12. Wire mesh has been provided on the outside of the scaffold to prevent debris or material from falling to lower levels.				
13. If safety netting is used, the scaffold has been designed to take the extra wind load.				
14. If the scaffold is on casters, the casters have been locked while work is being done.				
15. Mobile scaffold is not being moved while workers are on it.				
16. The scaffold planking is scaffold grade planking.				
17. The planking overhangs the supports by at least 6" but not more than 18".				

Part 15 Checklist: Daily Suspended Scaffold Inspection Version 1

Date _____

Daily Suspended Scaffold Inspection

Inspection by _____

Item Inspected	Yes	No	N/A	Comments
1. Tiebacks are secured to structural components.				
2. Independent lifelines are secured to independent anchorage.				
a. Lifelines have been protected from abrasion.				
b. Lifeline is terminated with a bowline or a rolling hitch knot.				
c. Lifeline reaches the lower level.				
3. Wire hoisting rope is in good condition.				
4. Fistgrips (3) are in good condition, have been installed properly and have been tightened to proper torque.				
5. Shackles are in good condition; secured by wire.				
6. Thimbles are being used in the eye and are in good condition.				
7. Platform-				
a. Proper overhang for stirrups				
b. Free of debris				
8. Guardrails have been installed on all open sides of the platform.				
9. Wire mesh has been installed around all open sides of the guardrail system.				
10. Uprights are in good condition and have been spaced at the proper intervals.				
11. Motors are in good condition. Emergency stop is operational.				
12. Stirrups are in good condition.				
13. Workers are utilizing personal fall arrest systems before getting on the scaffold.				
14. Rope grabs are being used properly (not knots) and are in good condition.				
15. Outriggers				
a. Calculations have been done by the rigging foreman and the proper amount of counterweights are being used.				
b. Counterweights have been secured.				
c. The outrigger beams are in good condition.				
d. Pipe frames or Delta frames are in good condition.				
e. Mudsills and baseplates are being used under the load bearing frames.				
16. Paperwork				
a. CD-5 (Outrigger notification) has been filed, approved and is available for inspection. (occupied building)				
b. Rigging foreman has been designated and has received a "Certificate of Fitness" from his/her employer. (occupied building)				
c. Employees working on the suspended scaffold trained by a recognized scaffold training course and all have completion cards on them.				
d. Department of Buildings approved copy of special rigger's license is available on the site.				
17. All wire rope termination points				
a. Shackle is being used.				
b. Thimble is being used.				
c. 3 J-Clamps are being used.				

Part 15 Checklist: Daily Supported Scaffold Inspection Version 2

Date _____

Daily Supported Scaffold Inspection

Inspection by _____

Complete each item before starting work.

1. Is all planking scaffold grade, or equivalent?
Yes _____ No _____ Comments _____
2. Are all working platforms fully planked between guardrails?
Yes _____ No _____ Comments _____
3. Do the planks have a minimum 12 " overlap and extend 6" beyond supports?
Yes _____ No _____ Comments _____
4. Are scaffold components and planking in safe condition and proper size for use?
Yes _____ No _____ Comments _____
5. Is the frame spacing and mudsill size capable of carrying intended loads?
Yes _____ No _____ Comments _____
6. Are all scaffolding frames braced with connecting components, stacking pins and cross bracing?
Yes _____ No _____ Comments _____
7. Have screw jacks been used to level and plumb the scaffold?
Yes _____ No _____ Comments _____
8. Is the scaffold level and plumb?
Yes _____ No _____ Comments _____
9. Is guard railing in place on all open sides of the scaffold?
Yes _____ No _____ Comments _____
10. Has been proper access been provided?
Yes _____ No _____ Comments _____
11. Has overhead protection safety netting or wire screening been provided where necessary?
Yes _____ No _____ Comments _____
12. Is the safety netting or wire screening maintained in good condition?
Yes _____ No _____ Comments _____
13. Has the scaffold been tied into the structure at a minimum of every 30 ft in length and 26 ft in height?
Yes _____ No _____ Comments _____
14. Have freestanding scaffold towers been guyed or tied every 26 ft in height?
Yes _____ No _____ Comments _____
15. If wheels or casters used are they in the locked position?
Yes _____ No _____ Comments _____
16. Are toe boards (4" to 6"), mid rails (21"), and top rails (42") properly installed and fastened?
Yes _____ No _____ Comments _____
17. Is the scaffold free of makeshift devices to increase the height?
Yes _____ No _____ Comments _____
18. Do the anchors and ties comply with the design?
Yes _____ No _____ Comments _____
19. The scaffold frames have not been overloaded with debris, material or work platforms.
Yes _____ No _____ Comments _____
20. Have possible hazardous conditions been reviewed for:
Power Lines? Yes _____ No _____ Comments _____
Wind? Yes _____ No _____ Comments _____
Other? Yes _____ No _____ Comments _____

Part 15 Checklist: Daily Suspended Scaffold Inspection Version 2

SUPPORT SYSTEM

1. All suspension-rigging points can support 4 times the intended load, and are tied back
Yes _____ No _____ Comments _____
2. The structure is able to support the loads (parapet wall, roof etc.).
Yes _____ No _____ Comments _____
3. Suspension lines terminated w/ shackle, thimble, 3-jclamps, spaced the same as the stirrups and the wire rope is long enough to reach the bottom of the drop.
Yes _____ No _____ Comments _____
4. Outriggers are rated for the application, correct # of counter weights attached and secured.
Yes _____ No _____ Comments _____
5. Parapet clamps and roof hooks are properly tightened and seated to the wall correctly.
Yes _____ No _____ Comments _____
6. All pipe scaffolds or outrigger supports are assembled per manufacturers instructions.
Yes _____ No _____ Comments _____
7. Tiebacks are properly configured, secured, tied to suitable anchorage points.
Yes _____ No _____ Comments _____
8. Power cord has stain relief at source; all edges it passes over are padded.
Yes _____ No _____ Comments _____

SUSPENDED EQUIPMENT

1. Operators have been briefed on equipment, and are qualified to use it safely.
Yes _____ No _____ Comments _____
2. Lifelines are independently tied back to suitable anchorage and abrasion protection provided.
Yes _____ No _____ Comments _____
3. Harnesses and lanyards are in good condition, rope grabber, snap hooks and fittings.
Yes _____ No _____ Comments _____
4. All parts (platform connections, toe boards, debris control netting, guardrails) of the scaffold have been properly installed and tightened with the correct bolts.
Yes _____ No _____ Comments _____
5. Hoists are in proper operating condition per manufacturers recommendations.
Yes _____ No _____ Comments _____
6. Have possible hazardous conditions been reviewed for:
Power Lines? Yes _____ No _____ Wind? Yes _____ No _____
Obstructions? Yes _____ No _____ Other? Yes _____ No _____
7. Every thing else appears to be operating properly.
Yes _____ No _____ Comments _____

The provisions of this section 13-03 shall take effect on and after [September 1, 2000] May 1. 2001.

Part 16: Signs, Signals, & Barricades

INTRODUCTION

On School Construction Authority Projects where Signs, Signal and Barricades are used, the Federal OSHA Standards, New York City Department of Building Codes and School Construction Authority Safety Manual shall be implemented. The most stringent of these standards shall be applicable.

BASIC TERMINOLOGY

Definitions for the following terms are listed alphabetically within the Glossary located at the back of this publication:

- Barricade
- Signs
- Signals
- Tags



SCA GENERAL REQUIREMENTS

1. All traffic concerns in relation to direction of flow, names of streets along with fire hydrants and signs shall be indicated on ALL Site Safety Plans for all project types.
2. Temporary walkways shall be protected by the use of barriers constructed of precast concrete when the walkway is in the street. Wooden timbers or plastic/PVC water filled barriers are not acceptable for use when temporary walkway is in the street.
3. Temporary walkways shall be installed and maintained in accordance with DOT Permit stipulations.

ACCIDENT PREVENTION SIGNS AND TAGS

Signs and symbols required by this section shall be visible at all times when work is being performed and shall be removed or covered promptly when the hazards no longer exist.

DANGER SIGNS

1. Danger signs shall be used only where an immediate hazard exists.

2. Danger signs shall have red as the predominating color for the upper panel; black outline on the borders; and a white lower panel for additional sign wording.

CAUTION SIGNS

1. Caution signs shall be used only to warn against potential hazards or to caution against unsafe practices.
2. Caution signs shall have yellow as the predominating color; black upper panel and borders; yellow lettering of “caution” on the black panel; and the lower yellow panel for additional sign wording. Black lettering shall be used for additional wording.
3. The standard color of the background shall be yellow; and the panel, black with yellow letters. Any letters used against the yellow background shall be black. The colors shall be those of opaque glossy samples as specified in Table 1 of American National Standard Z53.1-1967.

EXIT SIGNS

Exit signs, when required, shall be lettered in legible red letters, not less than 6 inches high, on a white field and the principal stroke of the letters shall be at least three fourths inch in width.

SAFETY INSTRUCTION SIGNS

Safety instruction signs, when used, shall be white with green upper panel with white letters to convey the principal message. Any additional wording on the sign shall be black letters on the white background.

DIRECTIONAL SIGNS

Directional signs, other than automotive traffic signs specified below in Traffic Signs of this section, shall be white with a black panel and a white directional symbol. Any additional wording on the sign shall be black letters on the white background.

TRAFFIC SIGNS

1. Construction areas shall be posted with legible traffic signs at points of hazard.
2. All traffic control signs or devices used for protection of construction workmen, pedestrians and vehicles shall conform to American National Standards Institute D6.1-1971, Manual on Uniform Traffic Control Devices for Streets and Highways 2003 Edition (MUTCD).

ACCIDENT PREVENTION TAGS

1. Accident prevention tags shall be used as a temporary means of warning employees of an existing hazard, such as defective tools, equipment, etc. They shall not be used in place of, or as a substitute for, accident prevention signs.
2. Specification for accident prevention tags shall conform to applicable OSHA Standards.

ADDITIONAL RULES

American National Standards Institute (ANSI) Z35.1-1968, Specifications for Accident Prevention Signs, and Z35.2-1968, Specifications for Accident Prevention Tags, contain rules, which are additional to the rules, prescribed in this section. The employer shall comply with ANSI Z35.1-1968 and Z35.2-1968 with respect to rules not specifically prescribed in this section.

SIGNALING

1. Flagmen. When operations are such that signs, signals, and barricades do not provide the necessary protection on or adjacent to a highway or street, flagmen or other appropriate traffic controls shall be provided.
2. Signaling directions by flagmen shall conform to American National Standards Institute D6.1-1971, Manual on Uniform Traffic Control Devices for Streets and Highways.
3. Hand signaling by flagmen shall be by use of red flags at least 18 inches square or sign paddles, and in periods of darkness, red lights.
4. Flagmen shall be provided with and shall wear a red or orange warning garment while flagging. Warning garments worn at night shall be of reflector material.

CRANE AND HOIST SIGNALS

Regulations for crane and hoist signaling will be found in applicable American National Standards Institute standards. Persons performing signaling for crane operations must complete a signalperson training program approved by the NYC Department of Buildings.

BARRICADES

All barricades used for protection of construction workmen pedestrians and vehicles shall conform to American National Standards Institute D6.1-1971, Manual on Uniform Traffic Control Devices for Streets and Highways 2003 Edition.

Part 17: Stairways & Ladders

INTRODUCTION

On School Construction Authority Projects where stairway and ladders are used the Federal OSHA Standards, New York City Department of Buildings Codes and School Construction Authority Safety Manual shall be implemented. The most stringent of these standards shall be applicable.

BASIC TERMINOLOGY

Definitions for the following terms are listed alphabetically within the Glossary located at the back of this publication:

- Cleat
- Double Cleat Ladder
- Equivalent
- Extension Trestle Ladder
- Failure
- Fixed Ladder
- Handrail
- Single Rail Ladder
- Job Made Ladder
- Lower Level
- Maximum Intended Load
- Nosing
- Point of Access
- Portable Ladder
- Riser Height
- Single Cleat Ladder
- Spiral Stairway
- Stair Rail System
- Step Stool
- Tread Depth
- Unprotected Sides and Edges
- Unstable Objects



SCA GENERAL REQUIREMENTS

“A” frame ladders shall not be used while closed.

The surface on which a ladder is to be set is to be free of obstruction and slip hazards.

Ladders are not to be used on scaffolds to increase the working level height of employees.

The top two (2) steps of the “A” frame ladder are not to be used.

Defective ladders are to be removed from service.

Stairways are to remain unobstructed and free of slip, trip, and fall hazards.

GENERAL REQUIREMENTS

Stairway or ladder shall be provided at all personnel point of access where there is a break in elevation of 19 inches or more, and no ramp, runway, sloped embankment or personnel hoist is provided.

Employees shall not use any spiral stairways that will not be a permanent part of the structure on which construction work is being performed.

A double cleated ladder or two or more separate ladders shall be provided when ladders are the only means of access or exit from a working area for 25 or more employees, or when a ladder is to serve simultaneous two-way traffic.

When a building or structure has two or more points of access between levels, at least one point of access shall be kept clear to permit free passage of employees. Access must be maintained within at least one stair/ladder-system continuously from the uppermost occupied floor to the buildings exit(s) in order for it to be considered free and clear.

Employers shall provide and install all stairway and ladder Fall Protection systems required by this section and shall comply with all other pertinent requirements of this section before employees begin the work that necessitates the installation and use of stairways, ladders, and their respective Fall Protection systems.

When working in an occupied school no school furniture such as chairs and desks shall be used to gain access to a higher level. The contractor is to supply their own ladders for the type of work they are involved in.

When working in an occupied school, ladders must be properly stored or removed at the end of each work shift and prior to the start of any and all school sessions. Ladders are not to be left in areas that are accessible to school occupants and/or the public.

Unstable objects shall not be used as a base support for ladders or stair treads nor shall they be used to form stair treads.

STAIRWAYS

Stairways that will not be a permanent part of the structure on which construction work is being performed shall have landings of not less than 30 inches in the direction of travel and extend at least 22 inches in width at every 12 feet or less of vertical rise.

Stairs shall be installed between 30 degrees and fifty degrees from horizontal.

Riser height and tread depth shall be uniform within each flight of stairs, including any foundation structure used as one or more treads of the stairs. Variations in riser height or tread depth shall not be over $\frac{1}{4}$ inch in any stairway system.

Where doors or gates open directly on a stairway, a platform shall be provided, and the swing of the door shall not reduce the effective width of the platform to less than 20 inches.

Metal pan landings and metal pan tread, when used, shall be secured in place before filling with concrete or other material.

All parts of stairways shall be free of hazardous projections, such as protruding nails.

Slippery conditions on stairways shall be eliminated before the stairways are used to reach other levels.

Where a building has been constructed to a height greater than 50 feet (15 240 mm) or four stories, or where an existing building exceeding 50 feet (15 240 mm) in height is altered or demolished, at least one temporary lighted stairway shall be provided, unless one or more of the permanent stairways are erected or maintained as the construction or demolition progresses.

The maximum distance between the working deck of a building under construction or demolition and the highest floor accessible to a temporary or permanent stair shall be no more than *40 feet or 4 floors*. In concrete construction, the working deck is the floor being formed. In steel construction the working deck is the floor where the metal decking and steel components are being placed before concrete is poured.

TEMPORARY SERVICE

Treads for temporary service shall be made of wood or other solid material, and shall be installed the full width and depth of the stair.

Except during stairway construction, foot traffic is prohibited on:

1. Stairways with pan stairs where the treads and/or landings are to be filled in with concrete or other material at a later date, unless the stairs are temporarily fitted with wood or other solid material at least to the top edge of each pan. Such temporary treads and landings shall be replaced when worn below the level of the top edge of the pan.
2. Skeleton metal stairs where permanent treads and/or landings are to be installed at a later date, unless the stairs are fitted with secured temporary treads and landings long enough to cover the entire tread and/or landing area.

STAIRRAILS AND HANDRAILS

1. Stairways having four or more risers or rising more than 30 inches whichever is less, shall be equipped with at least one handrail and one stairrail system along each unprotected edge.
2. Winding and spiral stairways shall be equipped with a handrail offset sufficiently to prevent walking on those portions of the stairways where the tread width is less than 6 inches.
3. The height of stairrails shall be as follows:



Requirement: Stairrails installed after March 15, 1991, shall be not less than 36 inches from the upper surface of the stairrail system to the surface of the tread, in line with the face of the riser at the forward edge of the tread.

Stairrails installed before March 15, 1991, shall be not less than 30 inches nor more than 34 inches from the upper surface of the stairrail system to the surface of the tread, in line with the face of the riser at the forward edge of the tread.

4. Midrails, screens, mesh, intermediate vertical member, or equivalent intermediate structural members, shall be provided between the top rail of the stairrail system and the stairway steps.
5. Midrails, when used, shall be located at a height midway between the top edge of the stairrail system and the stairway steps.
6. Screens or mesh, when used shall extend from the top rail to the stairway step, and along the entire opening between the rail supports.
7. When intermediate vertical members, such as balusters, are used between posts, they shall be not more than 19 inches apart.
8. Other structural members, when used, shall be installed such that there are no openings in the stairrail system that are more than 19 inches wide.

9. Handrails and the top rails of stairrail systems shall be capable of withstanding, without failure, a force of at least 200 pounds applied within 2 inches of the top edge, in any downward or outward direction, at any point along the top edge.
10. The height of handrails shall be not more than 37 inches nor less than 30 inches from the upper surface of the handrail to the surface of the tread, in line with the face of the riser at the forward edge of the tread.
11. When the top edge of a stairrail system also serves as a handrail, the height of the top edge shall be not more than 37 inches nor less than 36 inches from the upper surface of the stairrail system to the surface of the tread, in line with the face of the riser at the forward edge of the tread.
12. Stairrail systems and handrails shall be so surfaced as to prevent injury to employees from punctures or lacerations, and to prevent snagging of clothing.
13. Handrails shall provide an adequate handhold for employees grasping them to avoid falling.
14. The ends of stairrail systems and handrails shall be constructed so as not to constitute a projection hazard.
15. Handrails that will not be a permanent part of the structure being built shall have a minimum clearance of 3 inches between the handrail and walls, stairrail system and other objects.
16. Unprotected sides and edges of stairway landings shall be provided with guardrail systems. (guardrail systems requirements are addressed under the section – Fall Protection)

LADDERS

Ladders shall be capable of supporting the following loads without failure;

1. Self-Supporting Portable Ladder
 - a. At least four times the maximum intended load, except that each extra heavy duty type 1A metal or plastic ladder shall sustain at least 3.3 times the maximum intended load. The ability of a ladder to sustain the loads indicated in this section shall be determined by applying or transmitting the requisite load to the ladder in a downward vertical direction. Ladders built and tested in conformance with the applicable provisions of Appendix A of this section will be deemed to meet this requirement.
2. Portable Ladder That Is Not Self Supporting
 - a. At least four times the maximum intended load, except that each extra heavy duty type 1A metal or plastic ladders shall sustain at least 3.3 times the maximum intended load. The ability of a ladder to sustain the loads indicated this section shall be determined by applying or transmitting the requisite load to the ladder in a downward vertical direction when the ladder is placed at an angle of 75 and ½ degrees from the horizontal. Ladders built and tested in conformance with the applicable provisions of Appendix A of this section will be deemed to meet this requirement.
3. Fixed Ladder
 - a. At least tow loads of 250 pounds each, concentrated between any two consecutive attachments (the number and position of additional concentrated loads of 250 pound each, determined from anticipated usage of the ladder, shall also be included), plus anticipated loads caused by ice buildup, winds, rigging and impact loads resulting from the use of ladder safety devices. Each step or rung shall be capable of supporting a single concentrated load of at least 250 pounds applied in the middle of the step or rung. Ladders built in conformance with the applicable provisions of Appendix A will be deemed to meet this requirement.

4. Ladder rungs, cleats, and steps shall be parallel, level and uniformly spaced when the ladder is in position for use.
5. Rungs, cleats, and steps of portable ladders and fixed ladders (including individual rung/step ladders) shall be spaced not less than 10 inches apart, nor more than 14 inches apart, as measured between centerlines of rungs, cleats and steps.
6. Rungs, cleats and steps of step stools shall be not less than 8 inches apart, nor more than 12 inches apart, as measured between center lines of rungs, cleats, and steps.
7. Rungs, cleats, and steps of the base section of extension trestle ladders shall not be less than 8 inches nor more than 18 inches apart, as measured between center lines of the rungs, cleats, and steps. The rung spacing on the extension section of the extension trestle ladder shall be not less than 6 inches nor more than 12 inches as measured between center line of the rungs, cleats, and steps.
8. The minimum clear distance between the sides of individual rung/step ladders and the minimum clear distance between the side rails of other fixed ladders shall be 16 inches.
9. The minimum clear distance between side rails for all portable ladders shall be 11 and ½ inches.
10. The rungs of individual rung/step ladders shall be shaped such that employees' feet can not slide off the end of the rungs.
11. The rungs and steps of fixed metal ladders manufactured after March 15, 1991, shall be corrugated, knurled, dimpled, coated with skid resistant material, or otherwise treaded to minimize slipping.
12. The rungs and steps of portable metal ladders shall be corrugated, knurled, dimpled, coated with skid resistant material, or otherwise treated to minimize slipping.
13. Ladders shall not be tied or fastened together to provide longer sections unless they are specially designed to do so.
14. Length. Stepladders with side rails exceeding 20 feet in length shall not be used.
15. Tread depth. The depth of the steps or treads of any stepladder shall be not less than three inches.
16. Prohibited use. Stepladders shall not be used as supports for scaffold planking.
17. A metal spreader or locking device shall be provided on each stepladder to hold the front and back sections in an open position when the ladder is being used. When in use every stepladder shall be opened to its full position and the spreader shall be locked.
18. Ladder splicing: Ladders shall not be spliced to increase their length except that extension pieces may be spliced to the upper ends of ladders for use as handholds. Such extension pieces shall not bear against the ladder supporting object or structure.
19. Except when portable ladders are used to gain access to fixed ladders (such as those on utility towers, billboards and other structures where the bottom of the fixed ladder is elevated to limit access), when two or more separate ladders are used to reach an elevated work area, the ladders shall be offset with a platform or landing between the ladders. (The requirements to have guardrail system with toeboards for falling object and overhead protection on platforms and landings are set forth in the section titled – Fall Protection.
20. Ladder components shall be surfaced so as to prevent injury to an employee from punctures or lacerations, and to prevent snagging of clothing.
21. Wood ladders shall not be coated with any opaque covering, except for identification or warning labels, which may be placed on one face only of a side rail.
22. The minimum perpendicular clearance between fixed ladder rungs, cleats, and steps; any obstruction behind the ladders shall be 7 inches except in the case of an elevator pit ladder, for which a minimum perpendicular clearance of 4 and ½ inches is required.

23. The minimum perpendicular clearance between the center line of fixed ladder rungs, cleats, and steps, and any obstruction on the climbing side of the ladder shall be 30 inches except as provided in paragraph #22.
24. When unavoidable obstructions are encountered, the minimum perpendicular clearance between the centerline of fixed ladder rungs, cleats, and steps, and the obstruction on the climbing side of the ladder may be reduced to 24 inches provided that a deflection device is installed to guide employees around the obstruction.
25. Through fixed ladders at their point of access/egress shall have a step across distance of not less than 7 inches nor more than 12 inches as measured from the centerline of the steps or rungs to the nearest edge of the landing area. If the normal step across distance exceeds 12 inches a landing platform shall be provided to reduce the distance to the specified limit.
26. Fixed ladders without cages or wells shall have a clear width to the nearest permanent object of at least 15 inches on each side of the centerline of the ladder.
27. Fixed ladders shall be provided with cages, wells, ladder safety devices, or self-retracting lifelines where the length of climb is less than 24 feet above lower levels.
28. Where the total length of a climb equals or exceeds 24 feet, fixed ladders shall be equipped with one of the following:
 - a. Ladder safety devices
 - b. A cage or well, and multiple ladder sections, each ladder section not to exceed 50 feet in length. Ladder sections shall be offset from adjacent sections, and landing platforms shall be provided at maximum intervals of 50 feet.
29. Cages for fixed ladders shall conform to all of the following:
 - a. Horizontal bands shall be fastened to the side rails or rail ladders, or directly to the structure, building or equipment for individual rung ladders;
 - b. Vertical bars shall be on the inside of the horizontal bands and shall be fastened to them
 - c. Cages shall extend not less than 27 inches or more than 30 inches from the centerline of the step or rung (excluding the flare at the bottom of the cage), and shall not be less than 27 inches in width
 - d. The inside of the cage shall be clear of projection;
 - e. Horizontal bands shall be spaced not more than 4 feet on center vertically
 - f. Vertical bars shall be spaced at intervals not more than 9 and ½ inches on center horizontally
 - g. The bottom of the cage shall be at a level not less than 7 feet nor more than 8 feet above the point of access to the bottom of the ladder. The bottom of the cage shall be flared not less than 4 inches all around within the distance between the bottom horizontal band and the next higher band
 - h. The top of the cage shall be a minimum of 42 inches above the top of the platform, or the point of access at the top of the ladder, with provision for access to the platform or other point of access
30. Wells for fixed ladders shall conform to all of the following:
 - a. They shall completely encircle the ladder
 - b. They shall be free of projection;
 - c. Their inside face on the climbing side of the ladder shall extend not less than 27 inches nor more than 30 inches from the centerline of the step or rung;
 - d. The inside clear width shall be at least 30 inches

- e. The bottom of the wall on the access side shall start at a level not less than 7 feet nor more than 8 feet above the point of access to the bottom of the ladder.
31. Ladder safety devices, and related support systems, for fixed ladders shall conform to all of the following;
- a. They shall be capable of withstanding without failure a drop test consisting of an 18 inch drop of a 500 pound weight
 - b. They shall permit the employee using the device to ascend or descend without continually having to hold, push or pull any part of the device, leaving both hands free for climbing
 - c. They shall be activated within 2 feet after a fall occurs, and limit the descending velocity of an employee to 7 feet/second, or less.
 - d. The connection between the carrier or lifeline and the point of attachment to the body belt or harness shall not exceed 9 inches in length.
32. The mounting of ladder safety devices for fixed ladders shall conform to the following;
- a. Mountings for rigid carriers shall be attached at each end of the carrier, with intermediate mountings, as necessary, spaced along the entire length of the carrier, to provide the strength necessary to stop employees' falls.
 - b. Mountings for flexible carriers shall be attached at each end of the carrier. When the system is exposed to wind, cable guides for flexible carriers shall be installed at a minimum spacing of 25 feet and maximum spacing of 40 feet along the entire length of the carrier, to prevent wind damage to the system.
 - c. The design and installation of mountings and cable guides shall not reduce the design strength of the ladder.
33. The side rails of through or side step fixed ladders shall extend 42 inches above the top of the access level or landing platform served by the ladder. For a parapet ladder, the access level shall be the roof if the parapet is cut to permit passage through the parapet; if the parapet is continuous, the access level shall be the top of the parapet.
34. For through fixed ladder extensions, the steps or rungs shall be omitted from the extension of the side rails shall be flared to provide not less than 24 inches nor more than 30 inches clearance between side rails. Where ladder safety devices are provided, the maximum clearance between side rails of the extensions shall not exceed 36 inches.
35. For side step fixed ladders, the side rails and the steps or rungs shall be continuous in the extension.
36. Individual rung/step ladders, except those used where their access openings are covered with manhole covers or hatches, shall extend at least 42 inches above an access level or landing platform either by the continuation of the rung spacing as horizontal grab bars or by providing vertical grab bars that shall have the same lateral spacing as the vertical legs of the rungs.

USE

1. When portable ladders are used for access to an upper landing surface, the ladder side rails shall extend at least 3 feet above the upper landing surface to which the ladder is used to gain access; or, when such an extension is not possible because of the ladder's length, the ladder shall be secured at its top to a rigid support that will not deflect, and a grasping device such as a grabrail, shall be provided to assist employees in mounting and dismounting the ladder. In no case shall the extension be such that ladder deflection under a load would, by itself, cause the ladder to slip off its support.

2. Ladders shall be maintained free of oil, grease and other slipping hazards.
3. Ladders shall not be loaded beyond the maximum intended load for which they were built, nor beyond their manufacturer's rated capacity.
4. Ladders shall be used only for the purpose for which they were designed.
5. Non self-supporting ladders shall be used at an angle such that the horizontal distance from the top support to the foot of the ladder is approximately one quarter of the working length of the ladder (the distance along the ladder between the foot and the top support).
6. Fixed ladders shall be used at a pitch no greater than 90 degrees from the horizontal, as measured to the backside of the ladder.
7. Ladders shall be used only on stable and level surfaces unless secured to prevent accidental displacement.
8. Ladders shall not be used on slippery surfaces unless secured or provided with slip resistant feet to prevent accidental displacement. Slip resistant feet shall not be used as a substitute for care in placing, lashing or holding a ladder that is used upon slippery surfaces including, but not limited to, flat metal or concrete surfaces that are constructed so they can not be prevented from becoming slippery.
9. Ladders placed in any location where they can be displaced by workplace activities or traffic, such as in passageways, doorways, or driveways, shall be secured to prevent accidental displacement, or a barricade shall be used to keep the activities or traffic away from the ladder. Ladders shall not be placed in door openings unless the doors are securely fastened open, closed and locked or otherwise effectively guarded against swinging.
10. The area around the top and bottom of ladders shall be kept clear.
11. The top of a non-self supporting ladder shall be placed with the two rails supported equally unless it is equipped with a single support attachment.
12. Ladders shall not be moved, shifted or extended while occupied.
13. Ladders shall have nonconductive siderails if they are used where the employee or the ladder could contact exposed energized electrical equipment.
14. The top or top step of a stepladder shall not be used as a step.
15. Cross bracing on the rear section of stepladders shall not be used for climbing unless the ladder s are designed and provided with steps for climbing on both front and rear sections.
16. Ladders shall be inspected by a competent person for visible defects on a periodic basis and after any occurrence that could affect their safe use.
17. Portable ladders with structural defect, such as, but not limited to, broken or missing rungs, cleats, or steps, broken or split rails, corroded components, or other faulty or defective components, shall either be immediately marked in a manner that readily identifies them as defective, or be tagged with "Do Not Use" or similar language, and shall be withdrawn from service until repaired.
18. Fixed ladders with structural defects, such as, but not limited to, broken or missing rungs, cleats or steps, broken or split rails, or corroded components, shall be withdrawn from service until repaired. The requirement to withdraw a defective ladder from service is satisfied if the ladder is either
 - a. Immediately tagged with "Do Not Use" or similar language
 - b. Marked in a manner that readily identified it as defective
 - c. Blocked (such as with a plywood attachment that spans several rungs)
19. Ladder repairs shall restore the ladder to a condition meeting its original design criteria, before the ladder is returned to use.

20. Single rail ladders shall not be used.
21. When ascending or descending a ladder, the user shall face the ladder.
22. Each employee shall use at least one hand to grasp the ladder when progressing up and/or down the ladder.
23. And employee shall not carry any object or load that could cause the employee to lose balance and fall.

TRAINING REQUIREMENTS

1. The employer shall provide a training program for each employee using ladders and stairways, as necessary. The program shall enable each employee to recognize the hazards related to ladders and stairways, and shall train each employee in the procedures to be followed to minimize these hazards.
2. The employer shall ensure that each employee has been trained by a competent person in the following areas, as applicable:
 - a. Nature Of Fall Hazards In The Work Area
 - b. Correct Procedures For Erecting, Maintaining And Disassembling The Fall Protection Systems To Be Used
 - c. Proper Construction, Use, Placement And Care In Handling Of All Stairways And Ladders
 - d. Maximum Intended Load Carrying Capacity Of Ladders Used
 - e. Standards contained in this part
3. Retraining shall be provided for each employee as necessary so that the employee maintains the understanding and knowledge acquired through compliance with this section.

Part 17 Appendix A: Ladders

LADDERS

This appendix serves as a non-mandatory guideline to assist employers in complying with the ladder loading and strength requirements. A ladder designed and built in accordance with the applicable national consensus standards, as set forth below, will be considered to meet the requirements of this section.

1. Manufactured portable wood ladders: American National Standards Institute (ANSI) A14.1-1982 – American National Standard for Ladders Portable Wood Safety Requirements.
2. Manufactured portable metal ladders: ANSI A14.2 – 1982 – American National Standard for Ladders – Portable Metal Safety Requirements.
3. Manufactured fixed ladders: ANSI A14.3 – 1984 – American National Standard for Ladders Fixed Safety Requirements.
4. Job made ladders: ANSI A14.4 – 1979 – Safety Requirements for Job Made Ladders.
5. Plastic ladders: ANSI A14.5-1982 – American National Standard for Ladders Portable Reinforced Plastic Safety Requirements.

STRUCTURAL RAMPS AND RUNWAYS

Application. This section does not apply to ramps constructed of earth, gravel, stone or similar embankment material.

1. Runways and ramps. All runways and ramps shall be substantially constructed and securely braced and supported.
2. Runways and ramps constructed for use by motor trucks or heavier vehicles shall be not less than 12 feet wide for single lane traffic or 24 feet wide for two-lane traffic.
3. Such runways and ramps shall be provided with timber curbs not less than 10 inches by 10 inches, full size timber, placed parallel to, and secured to the sides of such runways and ramps. The flooring of such runways and ramps shall be positively secured against movement and constructed of planking at least three inches thick full size or metal of equivalent strength.
4. Runways and ramps constructed for the use of persons only shall be at least 18 inches in width and shall be constructed of planking at least two inches thick full size or metal of equivalent strength. Such surface shall be substantially supported and braced to prevent excessive spring or deflection. Where planking is used it shall be laid close, butt jointed and securely nailed.
5. Runways and ramps constructed for the use of wheelbarrows, power buggies, handcarts or hand trucks shall be at least 48 inches in width. Such runways and ramps shall be constructed of planking at least two inches thick full size or metal of equivalent strength. Such runways and ramps shall be substantially supported and braced to prevent excessive spring or deflection. Where planking is used on such runways and ramps, it shall be laid close, butt jointed and securely nailed.

6. Such runways and ramps shall be provided with timber curbs at least two inches by eight inches full size, set on edge and placed parallel to, and secured to, the sides of such runways and ramps. Bracing for such runways and ramps shall be installed at a maximum of four-foot intervals.
7. Ramps shall have a slope not steeper than one in four. If the slope is steeper than one in eight, the ramp shall be provided with cleats spaced not more than fourteen inches apart or other equivalent slip resistant surface material and securely fastened to the planking to afford a foothold. Spaces in the cleats may be provided for the passage of the wheels of vehicles. The total rise of continuous ramp used by workers carrying material or using wheelbarrows, handcarts, or hand-trucks shall not exceed twelve feet unless broken by horizontal landings at least four feet in length.
8. Any runway or ramp constructed for the use of persons only which is located at, or extends to, a height of more than five feet above the ground, grade, floor or equivalent surface shall be provided with a standard guardrail and toe board constructed and installed in compliance with this Safety Program on every open side.
9. Where it is possible for the public to pass next to runways or ramps the space between the top-rail and the toe-board shall be enclosed with a wire screen of not less than number 18 steel wire gage or equivalent with a maximum one-half inch mesh.

PLATFORMS

1. Any platform used as a working area or used for the unloading of wheelbarrows, power buggies, hand carts or hand trucks shall be provided with a floor of planking at least two inches thick full size, exterior grade plywood at least three-quarters inch thick or metal of equivalent strength. Platforms used for motor trucks or heavier vehicles shall be provided with floors of planking at least three inches thick full size or metal of equivalent strength.
2. Every platform more than five feet above the ground, grade, floor or equivalent surface shall be provided with a standard guardrail and toe board constructed and installed in compliance with this Safety Program on all sides except those used for loading and unloading. Such sides when used for the loading or unloading of motor trucks or heavier vehicles shall be protected by timber curbs at least 10 inches by 10 inches full size and when used for the loading or unloading of wheelbarrows, power buggies, hand carts or hand trucks such sides shall be protected by timber curbs at least two inches by eight inches full size set on edge and secured to platform.
3. Where it is possible for the public to pass next to platforms the space between the top-rail and the toe-board shall be enclosed with a wire screen of not less than number 18 steel wire gage or equivalent with a maximum one-half inch mesh.

SPECIAL REQUIREMENTS FOR POWER BUGGIES

Runways, ramps, platforms, and other surfaces upon which power buggies are operated shall meet the following minimum requirements:

1. They shall be designed.
2. They shall be able to sustain, without failure, at least four times the maximum live load for which they are intended.
3. The minimum width, inside of curbs, for any ramp, runway, or platform shall be two feet wider than the outside width of any power buggy operated thereon without passing, and three feet wider than twice-such buggy width in the places where passing occurs.
4. All runways shall be essentially level transversely.

5. Curbs shall be furnished along all buggy traffic paths that are nearer than ten feet horizontally to any enclosed area, shaft, or other open space into which or through which, a fall of more than 12 inches from such surface is possible, except as set forth in subdivision seven of this section.
6. Where curbs are not required because the buggy is operated on a surface not over twelve inches above another surface, the lower surface shall be strong enough to sustain the loaded vehicle in the event of a fall thereon.
7. Curbs may be omitted at actual dumping points more than twelve inches above other surfaces if the edge over which dumping occurs is provided with bumpers or other means that will effectively stop the buggy from running over the edge while dumping.
8. Curbs must be at least seven inches high, securely fastened, and capable of resisting side impact, and shall be equivalent to at least two inches by eight inch plank set on edge against uprights securely fastened and braced at not more than four foot intervals.

Part 18: Steel Erection

INTRODUCTION

On School Construction Authority Projects where concrete & masonry construction is to take place Federal OSHA Standards, New York City Department of Building Codes and School Construction Authority Safety Manual shall be implemented. The most stringent of these standards shall be applicable.

BASIC TERMINOLOGY

Definitions for the following terms are listed alphabetically within the Glossary located at the back of this publication:

- Anchored Bridging
- Bolted Diagonal Bridging
- Bridging Clip
- Bridging Terminus Point
- Choker
- Cold Forming
- Column
- Competent Person
- Connector
- Constructibility
- Construction Load
- Controlled Decking Zone (CDZ)
- Controlled Load Lowering
- Controlling Contractor
- Critical Lift
- Decking Hole
- Derrick Floor
- Double Connection
- Double Connection Seat
- Erection Bridging
- Fall Restraint System
- Final Interior Perimeter
- Girt
- Headache Ball
- Hoisting Equipment
- Leading Edge
- Metal Decking
- Multiple Lift Rigging
- Opening
- Permanent Floor
- Personal Fall Arrest System
- Positioning Device System
- Post
- Project Structural Engineer of Record
- Purlin
- Qualified Person
- Safety Deck Attachment
- Shear Connector
- Steel Erection
- Steel Joist
- Steel Joist Girder
- Steel Truss
- Structural Steel
- System Engineered Metal Building
- Tank
- Unprotected Sides and Edges

SCOPE

This subpart sets forth requirements to protect employees from the hazards associated with steel erection activities involved in the construction, alteration, and/or repair of single and multi-story buildings, bridges,

and other structures where steel erection occurs. The requirements of this subpart apply to employers engaged in steel erection unless otherwise specified. This subpart does not cover electrical transmission towers, communication and broadcast towers, or tanks.

	Example:	Structures where steel erection may occur include but are not limited to the following: Single and multi-story buildings; systems-engineered metal buildings; lift slab/tilt-up structures; energy exploration structures; energy production, transfer and storage structures and facilities; auditoriums; malls; amphitheaters; stadiums; power plants; mills; chemical process structures; bridges; trestles; overpasses; underpasses; viaducts; aqueducts; aerospace facilities and structures; radar and communication structures; light towers; signage; billboards; scoreboards; conveyor systems; conveyor supports and related framing; stairways; stair towers; fire escapes; draft curtains; fire containment structures; monorails; aerialways; catwalks; curtain walls; window walls; store fronts; elevator fronts; entrances; skylights; metal roofs; industrial structures; hi-bay structures; rail, marine and other transportation structures; sound barriers; water process and water containment structures; air and cable supported structures; space frames; geodesic domes; canopies; racks and rack support structures and frames; platforms; walkways; balconies; atriums; penthouses; car dumpers; stackers/reclaimers; cranes and craneways; bins; hoppers; ovens; furnaces; stacks; amusement park structures and rides; and artistic and monumental structures.
---	-----------------	---

Steel erection activities include hoisting, laying out, placing, connecting, welding, burning, guying, bracing, bolting, plumbing and rigging structural steel, steel joists and metal buildings; installing metal decking, curtain walls, window walls, siding systems, miscellaneous metals, ornamental iron and similar materials; and moving point-to-point while performing these activities.

The following activities are covered by this subpart when they occur during and are a part of steel erection activities: rigging, hoisting, laying out, placing, connecting, guying, bracing, dismantling, burning, welding, bolting, grinding, sealing, caulking, and all related activities for construction, alteration and/or repair of materials and assemblies such as structural steel; ferrous metals and alloys; non-ferrous metals and alloys; glass; plastics and synthetic composite materials; structural metal framing and related bracing and assemblies; anchoring devices; structural cabling; cable stays; permanent and temporary bents and towers; falsework for temporary supports of permanent steel members; stone and other non-precast concrete architectural materials mounted on steel frames; safety systems for steel erection; steel and metal joists; metal decking and raceway systems and accessories; metal roofing and accessories; metal siding; bridge flooring; cold formed steel framing; elevator beams; grillage; shelf racks; multi-purpose supports; crane rails and accessories; miscellaneous, architectural and ornamental metals and metal work; ladders; railings; handrails; fences and gates; gratings; trench covers; floor plates; castings; sheet metal fabrications; metal panels and panel wall systems; louvers; column covers; enclosures and pockets; stairs; perforated metals; ornamental iron work, expansion control including bridge expansion joint assemblies; slide bearings; hydraulic structures; fascias; soffit panels; penthouse enclosures; skylights; joint fillers; gaskets; sealants and seals; doors; windows; hardware; detention/security equipment and doors, windows and hardware; conveying systems; building specialties; building equipment; machinery and plant equipment, furnishings and special construction.

The duties of controlling contractors under this subpart include, but are not limited to, the duties specified in the following sections: *Approval to begin Steel Erection*; *Site Layout*; *Repair Replacement or Field Modification of Anchor Rods*; *Protection From Falling Objects Other Than Materials Being Hoisted*; and *Custody of Fall Protection* of this subpart.

SITE LAYOUT, SITE SPECIFIC ERECTION PLAN AND CONSTRUCTION SEQUENCE

Approval to Begin Steel Erection

Before authorizing the commencement of steel erection, the controlling contractor shall ensure that the steel erector is provided with the following written notifications:

1. The concrete in the footings, piers and walls and the mortar in the masonry piers and walls has attained, on the basis of an appropriate ASTM standard test method of field-cured samples, either 75 percent of the intended minimum compressive design strength or sufficient strength to support the loads imposed during steel erection.
2. Any repairs, replacements and modifications to the anchor bolts were conducted in accordance with Repair Replacement or Field Modification of Anchor Rods.

Commencement of Steel Erection

A steel erection contractor shall not erect steel unless it has received written notification that the concrete in the footings, piers and walls or the mortar in the masonry piers and walls has attained, on the basis of an appropriate ASTM standard test method of field-cured samples, either 75 percent of the intended minimum compressive design strength or sufficient strength to support the loads imposed during steel erection.

Site Layout

The controlling contractor shall ensure that the following is provided and maintained:

18. Adequate access roads into and through the site for the safe delivery and movement of derricks, cranes, trucks, other necessary equipment, and the material to be erected and means and methods for pedestrian and vehicular control.



Exception: This requirement does not apply to roads outside of the construction site.

19. A firm, properly graded, drained area, readily accessible to the work with adequate space for the safe storage of materials and the safe operation of the erector's equipment.

Pre-Planning of Overhead Hoisting Operations

All hoisting operations in steel erection shall be pre-planned to ensure that the requirements of Working Under Loads are met.

Site-Specific Erection Plan

Where employers elect, due to conditions specific to the site, to develop alternate means and methods that provide employee protection in accordance with Hoisting and Rigging, Open Web Steel joists or Landing and placing loads, a site-specific erection plan shall be developed by a qualified person and be available at the work site. Guidelines for establishing a site-specific erection plan are contained in Appendix A to this subpart.

HOISTING AND RIGGING

All the provisions of Cranes and Derricks apply to hoisting and rigging.

In addition, the following sections, below, apply regarding the hazards associated with hoisting and rigging: *General*; *Working Under Loads*; and *Multiple Lift Rigging*.

General Requirements

1. Pre-shift visual inspection of cranes.
 - a. Cranes being used in steel erection activities shall be visually inspected prior to each shift by a competent person; the inspection shall include observation for deficiencies during operation. At a minimum this inspection shall include the following:
 - b. All control mechanisms for maladjustments;
 - c. Control and drive mechanism for excessive wear of components and contamination by lubricants, water or other foreign matter;
 - d. Safety devices, including but not limited to boom angle indicators, boom stops, boom kick out devices, anti-two block devices, and load moment indicators where required;
 - e. Air, hydraulic, and other pressurized lines for deterioration or leakage, particularly those which flex in normal operation;
 - f. Hooks and latches for deformation, chemical damage, cracks, or wear;
 - g. Wire rope reeving for compliance with hoisting equipment manufacturer's specifications;
 - h. Electrical apparatus for malfunctioning, signs of excessive deterioration, dirt, or moisture accumulation;
 - i. Hydraulic system for proper fluid level;
 - j. Tires for proper inflation and condition;
 - k. Ground conditions around the hoisting equipment for proper support, including ground settling under and around outriggers, ground water accumulation, or similar conditions;
 - l. The hoisting equipment for level position; and
 - m. The hoisting equipment for level position after each move and setup.
2. If any deficiency is identified, an immediate determination shall be made by the competent person as to whether the deficiency constitutes a hazard.
3. If the deficiency is determined to constitute a hazard, the hoisting equipment shall be removed from service until the deficiency has been corrected.
4. The operator shall be responsible for those operations under the operator's direct control. Whenever there is any doubt as to safety, the operator shall have the authority to stop and refuse to handle loads until safety has been assured.
5. A qualified rigger (a rigger who is also a qualified person) shall inspect the rigging prior to each shift in accordance with Materials Handling, Storage, Use and Disposal.
6. The headache ball, hook or load shall not be used to transport personnel except as provided in this section.
7. Cranes or derricks may be used to hoist employees on a personnel platform when work under this subpart is being conducted, provided that all provisions of Cranes and Derricks (except for General Requirements) are met.
8. Safety latches on hooks shall not be deactivated or made inoperable except:
 - a. When a qualified rigger has determined that the hoisting and placing of purlins and single joists can be performed more safely by doing so

- b. When equivalent protection is provided in a site-specific erection plan

Working Under Loads

1. Routes for suspended loads shall be pre-planned to ensure that no employee is required to work directly below a suspended load except for:
 - a. Employees engaged in the initial connection of the steel
 - b. Employees necessary for the hooking or unhooking of the load
2. When working under suspended loads, the following criteria shall be met:
 - a. Materials being hoisted shall be rigged to prevent unintentional displacement
 - b. Hooks with self-closing safety latches or their equivalent shall be used to prevent components from slipping out of the hook
 - c. All loads shall be rigged by a qualified rigger



Multiple Lift Rigging Procedure

1. Multiple Lift Rigging is NOT permitted to take place on SCA Projects.

STRUCTURAL STEEL ASSEMBLY

Structural stability shall be maintained at all times during the erection process.

Multi-Story Requirements

The following additional requirements shall apply for multi-story structures:

1. The permanent floors shall be installed as the erection of structural members progresses, and there shall be not more than eight stories between the erection floor and the upper-most permanent floor, except where the structural integrity is maintained as a result of the design.
2. At no time shall there be more than four floors or 48 feet (14.6 m), whichever is less, of unfinished bolting or welding above the foundation or uppermost permanently secured floor, except where the structural integrity is maintained as a result of the design.
3. A fully planked or decked floor or nets shall be maintained within two stories or 30 feet (9.1 m), whichever is less, directly under any erection work being performed.

Walking/Working Surfaces - Shear Connectors and Other Similar Devices

Tripping Hazards

Shear connectors (such as headed steel studs, steel bars or steel lugs), reinforcing bars, deformed anchors or threaded studs shall not be attached to the top flanges of beams, joists or beam attachments so that they project vertically from or horizontally across the top flange of the member until after the metal decking, or other walking/working surface, has been installed.

Installation of Shear Connectors on Composite Floors, Roofs and Bridge Decks

When shear connectors are used in construction of composite floors, roofs and bridge decks, employees shall lay out and install the shear connectors after the metal decking has been installed, using the metal

decking as a working platform. Shear connectors shall not be installed from within a controlled decking zone (CDZ), as specified in Fall Protection of this subpart.

Plumbing-Up

6. When deemed necessary by a competent person, plumbing-up equipment shall be installed in conjunction with the steel erection process to ensure the stability of the structure.
7. When used, plumbing-up equipment shall be in place and properly installed before the structure is loaded with construction material such as loads of joists, bundles of decking or bundles of bridging.
8. Plumbing-up equipment shall be removed only with the approval of a competent person.

Metal Decking - Hoisting, Landing and Placing of Metal Decking Bundles

5. Bundle packaging and strapping shall not be used for hoisting unless specifically designed for that purpose.
6. If loose items such as dunnage, flashing, or other materials are placed on the top of metal decking bundles to be hoisted, such items shall be secured to the bundles.
7. Bundles of metal decking on joists shall be landed in accordance with Landing and Placing Loads.
8. Metal decking bundles shall be landed on framing members so that enough support is provided to allow the bundles to be unbanded without dislodging the bundles from the supports.
9. At the end of the shift or when environmental or jobsite conditions require, metal decking shall be secured against displacement.

Roof, Floor Holes, and Openings

Metal decking at roof and floor holes and openings shall be installed as follows:

17. Framed metal deck openings shall have structural members turned down to allow continuous deck installation except where not allowed by structural design constraints or constructibility.
18. Roof and floor holes and openings shall be decked over. Where large size, configuration or other structural design does not allow openings to be decked over (such as elevator shafts, stair wells, etc.) employees shall be protected in accordance with Fall Protection of this subpart.
19. Metal decking holes and openings shall not be cut until immediately prior to being permanently filled with the equipment or structure needed or intended to fulfill its specific use and which meets the strength requirements of Covering Roof and Floor Openings of this section, or shall be immediately covered.

Covering Roof and Floor Openings

1. Covers for roof and floor openings shall be capable of supporting, without failure, twice the weight of the employees, equipment and materials that may be imposed on the cover at any one time.
2. All covers shall be secured when installed to prevent accidental displacement by the wind, equipment or employees.
3. All covers shall be painted with high-visibility paint or shall be marked with the word "HOLE" or "COVER" to provide warning of the hazard.

4. Smoke dome or skylight fixtures that have been installed, are not considered covers for the purpose of this section unless they meet the strength requirements of paragraph (1) of this subdivision..

Decking Gaps Around Columns

Wire mesh, exterior plywood, or equivalent, shall be installed around columns where planks or metal decking do not fit tightly. The materials used must be of sufficient strength to provide Fall Protection for personnel and prevent objects from falling through.

Installation of Metal Decking

1. Except as provided in *Fall Protection*, metal decking shall be laid tightly and immediately secured upon placement to prevent accidental movement or displacement.
2. During initial placement, metal decking panels shall be placed to ensure full support by structural members.

Derrick Floors

1. A derrick floor shall be fully decked and/or planked and the steel member connections completed to support the intended floor loading.
2. Temporary loads placed on a derrick floor shall be distributed over the underlying support members so as to prevent local overloading of the deck material.

COLUMN ANCHORAGE

General Requirements for Erection Stability

1. All columns shall be anchored by a minimum of 4 anchor rods (anchor bolts).
2. Each column anchor rod (anchor bolt) assembly, including the column-to-base plate weld and the column foundation, shall be designed to resist a minimum eccentric gravity load of 300 pounds (136.2 kg) located 18 inches (.46m) from the extreme outer face of the column in each direction at the top of the column shaft.
3. Columns shall be set on level finished floors, pre-grouted leveling plates, leveling nuts, or shim packs which are adequate to transfer the construction loads.
4. All columns shall be evaluated by a competent person to determine whether guying or bracing is needed; if guying or bracing is needed, it shall be installed.

Repair, Replacement, or Field Modification of Anchor Rods

1. Anchor rods (anchor bolts) shall not be repaired, replaced or field-modified without the approval of the project structural engineer of record.
2. Prior to the erection of a column, the controlling contractor shall provide written notification to the steel erector if there has been any repair, replacement or modification of the anchor rods (anchor bolts) of that column.

BEAMS AND COLUMNS

General Requirements

1. During the final placing of solid web structural members, the load shall not be released from the hoisting line until the members are secured with at least two bolts per connection, of the same size and strength as shown in the erection drawings, drawn up wrench-tight or the equivalent as specified by the project structural engineer of record, except as specified in paragraph “Diagonal Bracing” of this section.
2. A competent person shall determine if more than two bolts are necessary to ensure the stability of cantilevered members; if additional bolts are needed, they shall be installed.

Diagonal Bracing

Solid web structural members used as diagonal bracing shall be secured by at least one bolt per connection drawn up wrench-tight or the equivalent as specified by the project structural engineer of record.

Double Connections at Columns or At Beam Webs Over a Column

1. When two structural members on opposite sides of a column web, or a beam web over a column, are connected sharing common connection holes, at least one bolt with its wrench-tight nut shall remain connected to the first member unless a shop-attached or field-attached seat or equivalent connection device is supplied with the member to secure the first member and prevent the column from being displaced.
2. If a seat or equivalent device is used, the seat (or device) shall be designed to support the load during the double connection process. It shall be adequately bolted or welded to both a supporting member and the first member before the nuts on the shared bolts are removed to make the double connection.

Column Splices

Each column splice shall be designed to resist a minimum eccentric gravity load of 300 pounds (136.2 kg) located 18 inches (.46 m) from the extreme outer face of the column in each direction at the top of the column shaft.

Perimeter Columns

Perimeter columns shall not be erected unless:

1. The perimeter columns extend a minimum of 48 inches (1.2 m) above the finished floor to permit installation of perimeter safety cables prior to erection of the next tier, except where constructability does not allow. (See Appendix F to this subpart.)
2. The perimeter columns have holes or other devices in or attached to perimeter columns at 42-45 inches (107-114 cm) above the finished floor and the midpoint between the finished floor and the top cable to permit installation of perimeter safety cables required by the *Fall Protection Perimeter Safety Cables* part of this manual, except where constructability does not allow. (See Appendix F to this subpart.)

OPEN WEB STEEL JOISTS

General Requirements

1. Except as provided in paragraph (2) of this section, where steel joists are used and columns are not framed in at least two directions with solid web structural steel members, a steel joist shall be field-bolted at the column to provide lateral stability to the column during erection. For the installation of this joist:
 - a. A vertical stabilizer plate shall be provided on each column for steel joists. The plate shall be a minimum of 6 inch by 6 inch (152 mm by 152 mm) and shall extend at least 3 inches (76 mm) below the bottom chord of the joist with a ^{13/16} inch (21 mm) hole to provide an attachment point for guying or plumbing cables.
 - b. The bottom chords of steel joists at columns shall be stabilized to prevent rotation during erection.
 - c. Hoisting cables shall not be released until the seat at each end of the steel joist is field-bolted, and each end of the bottom chord is restrained by the column stabilizer plate.
2. Where constructability does not allow a steel joist to be installed at the column:
 - a. an alternate means of stabilizing joists shall be installed on both sides near the column and shall:
 - b. provide stability equivalent to paragraph (1) above of this section;
 - c. be designed by a qualified person;
 - d. be shop installed; and
 - e. be included in the erection drawings.
 - f. hoisting cables shall not be released until the seat at each end of the steel joist is field-bolted and the joist is stabilized.
3. Where steel joists at or near columns span 60 feet (18.3 m) or less, the joist shall be designed with sufficient strength to allow one employee to release the hoisting cable without the need for erection bridging.
4. Where steel joists at or near columns span more than 60 feet (18.3 m), the joists shall be set in tandem with all bridging installed unless an alternative method of erection, which provides equivalent stability to the steel joist, is designed by a qualified person and is included in the site-specific erection plan.
5. A steel joist or steel joist girder shall not be placed on any support structure unless such structure is stabilized.

6. When steel joists are landed on a structure, they shall be secured to prevent unintentional displacement prior to installation.
7. No modification that affects the strength of a steel joist or steel joist girder shall be made without the approval of the project structural engineer of record.

Field-Bolted Joists

1. Except for steel joists that have been pre-assembled into panels, connections of individual steel joists to steel structures in bays of 40 feet (12.2 m) or more shall be fabricated to allow for field bolting during erection.
2. These connections shall be field-bolted unless constructability does not allow.
3. Steel joists and steel joist girders shall not be used as anchorage points for a fall arrest system unless written approval to do so is obtained from a qualified person.
4. A bridging terminus point shall be established before bridging is installed. (See Appendix C to this subpart.)

ATTACHMENT OF STEEL JOISTS AND STEEL JOIST GIRDERS

1. Each end of "K" series steel joists shall be attached to the support structure with a minimum of two ¹/₈-inch (3 mm) fillet welds 1 inch (25 mm) long or with two ¹/₂-inch (13 mm) bolts, or the equivalent.
2. Each end of "LH" and "DLH" series steel joists and steel joist girders shall be attached to the support structure with a minimum of two ¹/₄-inch (6 mm) fillet welds 2 inches (51 mm) long, or with two ³/₄-inch (19 mm) bolts, or the equivalent.
3. Except as provided in paragraph (4) of this section, each steel joist shall be attached to the support structure, at least at one end on both sides of the seat, immediately upon placement in the final erection position and before additional joists are placed.
4. Panels that have been pre-assembled from steel joists with bridging shall be attached to the structure at each corner before the hoisting cables are released.
5. For the erection of Steel Joists requirements see OSHA Sub-Part R 1926.757(c)
6. For the erection of Steel Joists for Erection Bridging requirements see OSHA Sub- Part R 1926.757(d)

LANDING AND PLACING LOADS

During the construction period, the employer placing a load on steel joists shall ensure that the load is distributed so as not to exceed the carrying capacity of any steel joist.

	Exception:	Paragraph (2) of this section, no construction loads are allowed on the steel joists until all bridging is installed and anchored and all joist-bearing ends are attached.
---	-------------------	--

1. The weight of a bundle of joist bridging shall not exceed a total of 1,000 pounds (454 kg). A bundle of joist bridging shall be placed on a minimum of three steel joists that are secured at one end. The edge of the bridging bundle shall be positioned within 1 foot (.30 m) of the secured end.
2. No bundle of decking may be placed on steel joists until all bridging has been installed and anchored and all joist bearing ends attached, unless all of the following conditions are met:

- a. The employer has first determined from a qualified person and documented in a site-specific erection plan that the structure or portion of the structure is capable of supporting the load;
 - b. The bundle of decking is placed on a minimum of three steel joists;
 - c. The joists supporting the bundle of decking are attached at both ends;
 - d. At least one row of bridging is installed and anchored;
 - e. The total weight of the bundle of decking does not exceed 4,000 pounds (1816 kg); and
 - f. Placement of the bundle of decking shall be in accordance with paragraph (3) of this section.
3. The edge of the construction load shall be placed within 1 foot (.30 m) of the bearing surface of the joist end.

SYSTEMS ENGINEERED METAL BUILDINGS

All of the requirements of this subpart apply to the erection of systems-engineered metal buildings except *Column Anchorage* and *Open Web Steel Joists*.

1. Each structural column shall be anchored by a minimum of four anchor rods (anchor bolts).
2. Rigid frames shall have 50 percent of their bolts or the number of bolts specified by the manufacturer (whichever is greater) installed and tightened on both sides of the web adjacent to each flange before the hoisting equipment is released.
3. Construction loads shall not be placed on any structural steel framework unless such framework is safely bolted, welded or otherwise adequately secured.
4. In girt and eave strut-to-frame connections, when girts or eave struts share common connection holes, at least one bolt with its wrench-tight nut shall remain connected to the first member unless a manufacturer-supplied, field-attached seat or similar connection device is present to secure the first member so that the girt or eave strut is always secured against displacement.
5. Both ends of all steel joists or cold-formed joists shall be fully bolted and/or welded to the support structure before:
 - a. Releasing the hoisting cables
 - b. Allowing an employee on the joists
 - c. Allowing any construction loads on the joists
6. Purlins and girts shall not be used as an anchorage point for a fall arrest system unless written approval is obtained from a qualified person.
7. Purlins may only be used as a walking/working surface when installing safety systems, after all permanent bridging has been installed and Fall Protection is provided.
8. Construction loads may be placed only within a zone that is within 8 feet (2.5 m) of the center-line of the primary support member.

FALLING OBJECT PROTECTION

Securing Loose Items Aloft

1. All materials, equipment, and tools, which are not in use while aloft, shall be secured against accidental displacement
2. Protection from falling objects other than materials being hoisted.
3. The controlling contractor shall bar other construction processes below steel erection unless overhead protection for the employees below is provided.

Fall Protection

General Requirements

Except as provided by paragraph “Connectors” of this section, each employee engaged in a steel erection activity who is on a walking/working surface with an unprotected side or edge more than 15 feet (4.6 m) above a lower level shall be protected from fall hazards by guardrail systems, safety net systems, personal fall arrest systems, positioning device systems or fall restraint systems.

Perimeter Safety Cables

On multi-story structures, perimeter safety cables shall be installed at the final interior and exterior perimeters of the floors as soon as the metal decking has been installed.

Connectors

Connectors and employees working in controlled decking zones shall be protected from fall hazards as provided in this and the next subdivision “Controlled Decking Zone (CDZ)”, respectively.

Each connector shall:

1. Be protected in accordance with paragraph “General Requirements” of this section from fall hazards of more than two stories or 30 feet (9.1 m) above a lower level, whichever is less;
2. Have completed connector training in accordance with *Training* of this section; and
3. Be provided, at heights over 15 and up to 30 feet above a lower level, with a personal fall arrest system, positioning device system or fall restraint system and wear the equipment necessary to be able to be tied off; or be provided with other means of protection from fall hazards in accordance with paragraph “General Requirements” of this section.

Controlled Decking Zone (CDZ)

A controlled decking zone may be established in that area of the structure over 15 and up to 30 feet above a lower level where metal decking is initially being installed and forms the leading edge of a work area.

In each CDZ, the following shall apply:

1. Each employee working at the leading edge in a CDZ shall be protected from fall hazards of more than two stories or 30 feet (9.1 m), whichever is less.
2. Access to a CDZ shall be limited to only those employees engaged in leading edge work.
3. The boundaries of a CDZ shall be designated and clearly marked. The CDZ shall not be more than 90 feet (27.4 m) wide and 90 (27.4 m) feet deep from any leading edge. The CDZ shall be marked by the use of control lines or the equivalent. Examples of acceptable procedures for demarcating CDZ's can be found in Appendix D to this subpart.

4. Each employee working in a CDZ shall have completed CDZ training in accordance with Training of this section.
5. Unsecured decking in a CDZ shall not exceed 3,000 square feet (914.4 m²).
6. Safety deck attachments shall be performed in the CDZ from the leading edge back to the control line and shall have at least two attachments for each metal decking panel.
7. Final deck attachments and installation of shear connectors shall not be performed in the CDZ.

Criteria for Fall Protection Equipment

Guardrail systems, safety net systems, personal fall arrest systems, positioning device systems and their components shall conform to the criteria in (see Appendix G to this subpart).

1. Fall arrest system components shall be used in fall restraint systems and shall conform to the criteria in FALL PROTECTION of this Safety Manual (see Appendix G). Either body belts or body harnesses shall be used in fall restraint systems.
2. Perimeter safety cables shall meet the criteria for guardrail systems in *Fall Protection* of this Safety Manual (see Appendix G).

Custody of Fall Protection

Fall protection provided by the steel erector shall remain in the area where steel erection activity has been completed, to be used by other trades, only if the controlling contractor or its authorized representative:

1. Has directed the steel erector to leave the fall protection in place; and
2. Has inspected and accepted control and responsibility of the fall protection prior to authorizing persons other than steel erectors to work in the area.

TRAINING

The following provisions supplement the requirements of Safety Training and Education regarding the hazards addressed in this subpart.

Personnel

Training required by this section shall be provided by qualified persons.

Fall Hazard

The employer shall provide a training program for all employees exposed to fall hazards.

The program shall include training and instruction in the following areas:

1. The recognition and identification of fall hazards in the work area
2. The use and operation of guardrail systems (including perimeter safety cable systems), personal fall arrest systems, positioning device systems, fall restraint systems, safety net systems, and other protection to be used
3. The correct procedures for erecting, maintaining, disassembling, and inspecting the Fall Protection systems to be used
4. The procedures to be followed to prevent falls to lower levels and through or into holes and openings in walking/working surfaces and walls

5. The Fall Protection requirements of this subpart

Special Programs

In addition to the training required above, the employer shall provide special training to employees engaged in the following activities.

Multiple Lift Rigging

The employer shall ensure that each employee who performs multiple lift rigging has been provided training in the following areas:

1. The nature of the hazards associated with multiple lifts
2. The proper procedures and equipment to perform multiple lifts required by *Multiple lift rigging procedure* of this subpart

Connector

The employer shall ensure that each connector has been provided training in the following areas:

1. The nature of the hazards associated with connecting
2. The establishment, access, proper connecting techniques and work practices required by *Double Connections at Columns and/or at Beam Webs Over a Column* and *Connectors* of this subpart

Controlled Decking Zone

Where CDZs are being used, the employer shall assure that each employee has been provided training in the following areas:

1. The nature of the hazards associated with work within a controlled decking zone
2. The establishment, access, proper installation techniques and work practices required by § 1926.760(c) and § 1926.754(e)

Part 18 Checklist: Pre-Steel Erection Checklist

PRE-STEEL ERECTION MEETING

The following safety regulations and considerations were reviewed during the meeting:

- ✓ Crane notification, permits, PE survey letter, and Crane Inspections
- ✓ Licensing information for Master Rigger and Crane operator
- ✓ All applicable permits such as DOB and DOT permits.
- ✓ Crane logistics plan; requirements for proper staging of materials (steel shake out locations). Site Layout: Contractor is to supply flagmen at construction gate when vehicles enter or exit or other operations that may affect the public. Work is to be coordinated with consideration to the school's arrival and departure schedule. Adequate access roads into and through the site for the safe delivery and movement of derricks, cranes, trucks, other necessary equipment, and the material to be erected and means and methods for pedestrian and vehicular control. Exception: this requirement does not apply to roads outside of the construction site. A firm, properly graded, drained area, readily accessible to the work with adequate space for the safe storage of materials and the safe operation of the erector's equipment.
- ✓
- ✓ It was discussed and agreed upon by all in attendance that the structural steel erection/crane operations will not be permitted to take place over workers. Erection is to be performed in a manner that prevents the above from occurring.
- ✓ The load is not to be released from hoisting line until member is secured with not less than two bolts at each connection point.
- ✓ Tag lines are to be used on all loads.
- ✓ Proper Containers are to be used for all fasteners when aloft (plastic buckets are not permitted).
- ✓ Requirements of the OSHA 1926 Subpart "R" Steel erection standard reviewed as follows.
Written notification on the Concrete in the footings, piers and walls to meet 75 % of the intended minimum compressive design strength or sufficient strength to support the loads imposed during steel erection

Pre-planning of overhead hoisting operations. All hoisting operations in steel erection shall be pre-planned to ensure that the requirements of § 1926.753(d) are met.

Site-specific erection plan. Where employers elect, due to conditions specific to the site, to develop alternate means and methods that provide employee protection in accordance with § 1926.753(c)(5), § 1926.757(a)(4) or § 1926.757(e)(4), a site-specific erection plan shall be developed by a qualified person and be available at the work site. Guidelines for establishing a site-specific erection plan are contained in Appendix A to this subpart.

Means and methods of providing overhead protection for all individuals. The Contractor must maintain all vertical netting, and canopies are to be provided at points of egress to the ground floor. The Contractor is to prevent access to areas with overhead concerns using fencing, barricades, catch platforms or any other method necessary to provide overhead protection for all.

Discussed proper storage and use of O₂, acetylene, LPG and flammable liquids. Must have fire department permits. Welders are to be certified.

Reviewed all PPE requirements for workers minimum head, eye, hand and proper attire.

Material handling. Material/debris shall not be placed closer than ten feet from the perimeter edge of any elevated floor and six feet from shafts where there is no vertical structure of sufficient strength to restrain the material. No materials may be thrown down from elevated floors.

FALL PROTECTION:

- ✓ Decks and/or nets are to be maintained within two stories or 30 feet; whichever is less, directly under any erection being performed.
- ✓ All holes (2" or more in least dimension) are to be covered (2x employee weight) or protected by a GR system.
- ✓ Perimeter Safety Cables shall be installed at the final interior and exterior perimeters of the floors as soon as the metal decking has been installed. Consideration is to be given to the slab height when calculating stanchion height. The cable is to be netted and secured to the deck immediately following placement of the slab.
- ✓ All workers engaged in steel erection activities with the exception of connectors and deck installers: Falls greater than 15 feet, individuals shall be protected (GR, PFA, SN, WL system, Position Device).
- ✓ Connectors/ Deck Installers: Shall be protected (as above) from falls greater than two stories or 30 feet whichever is less.
- ✓ Connectors: Falls greater than 15 feet and up to 30 feet provided with and wear personal fall arrest system in order to be able to tie off or provided with other means of fall protection namely the greater than 15 foot means of protection as described above.
- ✓ When working from a scaffold all the requirements of 1926 Subpart L shall apply.

Controlled Decking Zone Procedures. Where CDZs are being used, the employer shall assure that each employee has been provided training in the following areas:

The nature of the hazards associated with work within a controlled decking zone; and

The establishment, access, proper installation techniques and work practices required by § 1926.760(c) and § 1926.754(e).

Each employee working at the leading edge in a CDZ shall be protected from fall hazards of more than two stories or 30 feet (9.1 m), whichever is less.

Access to a CDZ shall be limited to only those employees engaged in leading edge work.

The boundaries of a CDZ shall be designated and clearly marked. The CDZ shall not be more than 90 feet (27.4 m) wide and 90 (27.4 m) feet deep from any leading edge. The CDZ shall be marked by the use of control lines or the equivalent. Examples of acceptable procedures for demarcating CDZ's can be found in OSHA 1926 R Appendix D.

Each employee working in a CDZ shall have completed CDZ training in accordance with § 1926.761.

Unsecured decking in a CDZ shall not exceed 3,000 square feet (50 x 60 example)(914.4 m²).

Safety deck attachments shall be performed in the CDZ from the leading edge back to the control line and shall have at least two attachments for each metal decking panel.

Final deck attachments and installation of shear connectors (pins) shall not be performed in the CDZ.

Criteria for fall protection equipment.

Guardrail systems, safety net systems, personal fall arrest systems, positioning device systems and their components shall conform to the criteria in § 1926.502 (see Appendix G to this subpart).

Fall arrest system components shall be used in fall restraint systems and shall conform to the criteria in § 1926.502 (see Appendix G in Subpart R).

Perimeter safety cables shall meet the criteria for guardrail systems in § 1926.502 (see Appendix G).

Fall hazard training. The employer shall provide a training program for all employees exposed to fall hazards. The program shall include training and instruction in the following areas:

The recognition and identification of fall hazards in the work area;

The use and operation of guardrail systems (including perimeter safety cable systems), personal fall arrest systems, positioning device systems, fall restraint systems, safety net systems, and other protection to be used;

The correct procedures for erecting, maintaining, disassembling, and inspecting the fall protection systems to be used;

The procedures to be followed to prevent falls to lower levels and through or into holes and openings in walking/working surfaces and walls; and

The fall protection requirements of Subpart R.

Special training programs. In addition to the training required in paragraphs (a) and (b) of this section, the employer shall provide special training to employees engaged in the following activities.

Multiple lift rigging procedure. NO CHRISTMAS TREE ON SCA PROJECTS

Connector procedures. The employer shall ensure that each connector has been provided training in the following areas:

The nature of the hazards associated with connecting; and

The establishment, access, proper connecting techniques and work practices required by § 1926.756(c) and § 1926.760(b).

Part 18 Appendix A: Site-specific Erection Plan

GUIDELINES

1. General. This appendix serves as a guideline to assist employers who elect to develop a site-specific erection plan with alternate means and methods to provide employee protection.
2. Development of a site-specific erection plan. Preconstruction conference(s) and site inspection(s) are held between the erector and the controlling contractor, and others such as the project engineer and fabricator before the start of steel erection. The purpose of such conference(s) is to develop and review the site-specific erection plan that will meet the requirements of this section.
3. Components of a site-specific erection plan. In developing a site-specific erection plan, a steel erector considers the following elements:
 - a. The sequence of erection activity, developed in coordination with the controlling contractor, that includes the following:

Material deliveries:

 - i. Material staging and storage
 - ii. Coordination with other trades and construction activities
 - b. A description of the crane and derrick selection and placement procedures, including the following:

Site preparation;

 - i. Path for overhead loads
 - ii. Critical lifts, including rigging supplies and equipment
 - iii. A description of steel erection activities and procedures, including the following:
 - iv. Stability considerations requiring temporary bracing and guying;
 - v. Erection bridging terminus point;
 - vi. Anchor rod (anchor bolt) notifications regarding repair, replacement and modifications;
 - vii. Columns and beams (including joists and purlins)
 - viii. Connections
 - ix. Decking
 - x. Ornamental and miscellaneous iron

- c. A description of the fall protection procedures that will be used to comply with this subpart.
 - d. A description of the procedures that will be used to comply with § 1926.759.
 - e. A description of the special procedures required for hazardous non-routine tasks.
 - f. A certification for each employee who has received training for performing steel erection operations as required by *Training* of this subpart.
 - g. A list of the qualified and competent persons.
 - h. A description of the procedures that will be utilized in the event of rescue or emergency response.
4. Other plan information. The plan:
- a. Includes the identification of the site and project
 - b. Is signed and dated by the qualified person(s) responsible for its preparation and modification

Part 18 Appendix B: Testing Slip-Resistance of Walking/Working Surfaces.

COMPLYING WITH SLIP RESISTANCE OF SKELETAL STRUCTURAL STEEL

The following references provide acceptable test methods for complying with the requirements of this subpart.

1. Standard Test Method for Using a Portable Inclineable Articulated Strut Slip Tester (PIAST)(ASTM F1677-96)
2. Standard Test Method for Using a Variable Incidence Tribometer (VIT)(ASTM F1679-96)

Part 18 Appendix C:

Illustrations of Bridging Terminus Points

(see appendix C to OSHA 1926 sub-part R for illustrations)

Part 18 Appendix D: Illustration of the Use of Control Lines to CDZs

ILLUSTRATION OF THE USE OF CONTROL LINES TO DZS

Non-mandatory Guidelines for Complying with this subpart:

1. When used to control access to areas where leading edge and initial securement of metal deck and other operations connected with leading edge work are taking place, the controlled decking zone (CDZ) is defined by a control line or by any other means that restricts access.
 - a. A control line for a CDZ is erected not less than 6 feet (1.8 m) nor more than 90 feet (27.4 m) from the leading edge.
 - b. Control lines extend along the entire length of the unprotected or leading edge and are approximately parallel to the unprotected or leading edge.
 - c. Control lines are connected on each side to a guardrail system, wall, stanchion or other suitable anchorage.
2. Control lines consist of ropes, wires, tapes, or equivalent materials, and supporting stanchions as follows:
 - a. Each line is rigged and supported in such a way that its lowest point (including sag) is not less than 39 inches (1.0 m) from the walking/working surface and its highest point is not more than 45 inches (1.3 m) from the walking/working surface.
 - b. Each line has a minimum breaking strength of 200 pounds (90.8 kg).

Part 18 Appendix E: Training

TRAINING REQUIREMENTS

Training: Non-mandatory Guidelines for Complying with *Training* of this subpart.

The training requirements of this subpart will be deemed to have been met if employees have completed a training course on steel erection, including instruction in the provisions of this standard, that has been approved by the U.S. Department of Labor Bureau of Apprenticeship.

Part 18 Appendix F: Perimeter Columns

ABOUT PERIMETER COLUMNS

Perimeter Columns: Non-Mandatory Guidelines for Complying with *Perimeter Columns* To Protect the Unprotected Side or Edge of a Walking/Working Surface

In multi-story structures, when holes in the column web are used for perimeter safety cables, the column splice must be placed sufficiently high so as not to interfere with any attachments to the column necessary for the column splice. Column splices are recommended to be placed at every other or fourth levels as design allows. Column splices at third levels are detrimental to the erection process and should be avoided if possible.

Part 18 Appendix G: Guardrail Systems

FALL PROTECTION SYSTEMS CRITERIA AND PRACTICES

Guardrail systems and their use shall comply with the following provisions:

1. Top edge height of top rails, or equivalent guardrail system members, shall be 42 inches (1.1 m) plus or minus 3 inches (8 cm) above the walking/working level. When conditions warrant, the height of the top edge may exceed the 45-inch height, provided the guardrail system meets all other criteria of *FALL PROTECTION* of this Safety Manual.

Note: When employees are using stilts, the top edge height of the top rail, or equivalent member, shall be increased an amount equal to the height of the stilts.

2. Midrails, screens, mesh, intermediate vertical members, or equivalent intermediate structural members shall be installed between the top edge of the guardrail system and the walking/working surface when there is no wall or parapet wall at least 21 inches (53 cm) high.
 - a. Midrails, when used, shall be installed at a height midway between the top edge of the guardrail system and the walking/working level.
 - b. Screens and mesh, when used, shall extend from the top rail to the walking/working level and along the entire opening between top rail supports.
 - c. Intermediate members (such as balusters), when used between posts, shall be not more than 19 inches (48 cm) apart.
 - d. Other structural members (such as additional midrails and architectural panels) shall be installed such that there are no openings in the guardrail system that are more than 19 inches (.5 m) wide.
3. Guardrail systems shall be capable of withstanding, without failure, a force of at least 200 pounds (890 N) applied within 2 inches (5.1 cm) of the top edge, in any outward or downward direction, at any point along the top edge.
4. When the 200 pound (890 N) test load specified in paragraph (3) of this section is applied in a downward direction, the top edge of the guardrail shall not deflect to a height less than 39 inches (1.0 m) above the walking/working level. Guardrail system components selected and constructed in accordance with the appendix B of *FALL PROTECTION* of this Safety Manual will be deemed to meet this requirement.
5. Under no circumstances shall exterior tarps be secured to the top rail or midrail of perimeter guardrail systems. A separate means of anchorage is to be used for securing tarps.

6. Midrails, screens, mesh, intermediate vertical members, solid panels, and equivalent structural members shall be capable of withstanding, without failure, a force of at least 150 pounds (666 N) applied in any downward or outward direction at any point along the midrail or other member.
7. Guardrail systems shall be so surfaced as to prevent injury to an employee from punctures or lacerations, and to prevent snagging of clothing.
8. The ends of all top rails and midrails shall not overhang the terminal posts, except where such overhang does not constitute a projection hazard.
9. Steel banding and plastic banding shall not be used as top rails or midrails.
10. Top rails and midrails shall be at least one-quarter inch (0.6 cm) nominal diameter or thickness to prevent cuts and lacerations. If wire rope is used for top rails, it shall be flagged at not more than 6-foot intervals with high-visibility material.
11. When guardrail systems are used at hoisting areas, a chain, gate or removable guardrail section shall be placed across the access opening between guardrail sections when hoisting operations are not taking place.
12. When guardrail systems are used at holes, they shall be erected on all unprotected sides or edges of the hole.
13. When guardrail systems are used around holes used for the passage of materials, the hole shall have not more than two sides provided with removable guardrail sections to allow the passage of materials. When the hole is not in use, it shall be closed over with a cover, or a guardrail system shall be provided along all unprotected sides or edges.
14. When guardrail systems are used around holes which are used as points of access (such as ladderways), they shall be provided with a gate, or be so offset that a person cannot walk directly into the hole.
15. Guardrail systems used on ramps and runways shall be erected along each unprotected side or edge.
16. Manila, plastic or synthetic rope being used for top rails or midrails shall be inspected as frequently as necessary to ensure that it continues to meet the strength requirements of paragraph (3) of this section (§ 1926.502).

SAFETY NET SYSTEMS

Safety net systems and their use shall comply with the following provisions:

1. Safety nets shall be installed as close as practicable under the walking/working surface on which employees are working, but in no case more than 30 feet (9.1 m) below such level. When nets are used on bridges, the potential fall area from the walking/working surface to the net shall be unobstructed.
2. Safety nets shall extend outward from the outermost projection of the work surface as follows:

Vertical Distance (Working level to horizontal plane of net)	Minimum Required Horizontal Distance (Outer edge of net from the edge of the working surface)
Up to 5 feet	8 feet
More than 5 feet up to 10 feet	10 feet
More than 10 feet	13 feet

3. Safety nets shall be installed with sufficient clearance under them to prevent contact with the surface or structures below when subjected to an impact force equal to the drop test specified in paragraph (4) of this section.

4. Safety nets and their installations shall be capable of absorbing an impact force equal to that produced by the drop test specified in paragraph (a) of this section.
 - a. Except as provided in paragraph (b) of this section, safety nets and safety net installations shall be drop-tested at the jobsite after initial installation and before being used as a fall protection system, whenever relocated, after major repair, and at 6-month intervals if left in one place. The drop-test shall consist of a 400 pound (180 kg) bag of sand 30+ or -2 inches (76+ or -5 cm) in diameter dropped into the net from the highest walking/working surface at which employees are exposed to fall hazards, but not from less than 42 inches (1.1 m) above that level.
 - b. When the employer can demonstrate that it is unreasonable to perform the drop-test required by paragraph (a) of this section, the employer (or a designated competent person) shall certify that the net and net installation is in compliance with the provisions of paragraphs (3) and (4-a) of this section by preparing a certification record prior to the net being used as a fall protection system. The certification record must include an identification of the net and net installation for which the certification record is being prepared; the date that it was determined that the identified net and net installation were in compliance with paragraph (3) of this section and the signature of the person making the determination and certification. The most recent certification record for each net and net installation shall be available at the jobsite for inspection.
5. Defective nets shall not be used. Safety nets shall be inspected at least once a week for wear, damage, and other deterioration. Defective components shall be removed from service. Safety nets shall also be inspected after any occurrence which could affect the integrity of the safety net system.
6. Materials, scrap pieces, equipment, and tools which have fallen into the safety net shall be removed as soon as possible from the net and at least before the next work shift.
7. The maximum size of each safety net mesh opening shall not exceed 36 square inches (230 cm) nor be longer than 6 inches (15 cm) on any side, and the opening, measured center-to-center of mesh ropes or webbing, shall not be longer than 6 inches (15 cm). All mesh crossings shall be secured to prevent enlargement of the mesh opening.
8. Each safety net (or section of it) shall have a border rope for webbing with a minimum breaking strength of 5,000 pounds (22.2 kN).
9. Connections between safety net panels shall be as strong as integral net components and shall be spaced not more than 6 inches (15 cm) apart.

PERSONAL FALL ARREST SYSTEMS

Personal fall arrest systems and their use shall comply with the provisions set forth below. Effective January 1, 1998, body belts are not acceptable as part of a personal fall arrest system.

Note: The use of a body belt in a positioning device system is acceptable and is regulated under paragraph (4) of this section.

1. Connectors shall be drop forged, pressed or formed steel, or made of equivalent materials.
2. Connectors shall have a corrosion-resistant finish, and all surfaces and edges shall be smooth to prevent damage to interfacing parts of the system.
3. Dee-rings and snaphooks shall have a minimum tensile strength of 5,000 pounds (22.2 kN).
4. Dee-rings and snaphooks shall be proof-tested to a minimum tensile load of 3,600 pounds (16 kN) without cracking, breaking, or taking permanent deformation.
5. Snaphooks shall be sized to be compatible with the member to which they are connected to prevent unintentional disengagement of the snaphook by depression of the snaphook keeper by the

connected member, or shall be a locking type snaphook designed and used to prevent disengagement of the snaphook by the contact of the snaphook keeper by the connected member. Effective January 1, 1998, only locking type snaphooks shall be used.

6. Unless the snaphook is a locking type and designed for the following connections, snaphooks shall not be engaged:
 - a. Directly to webbing, rope or wire rope;
 - b. To each other;
 - c. To a dee-ring to which another snaphook or other connector is attached;
 - d. To a horizontal lifeline; or
 - e. To any object which is incompatibly shaped or dimensioned in relation to the snaphook such that unintentional disengagement could occur by the connected object being able to depress the snaphook keeper and release itself.
7. On suspended scaffolds or similar work platforms with horizontal lifelines which may become vertical lifelines, the devices used to connect to a horizontal lifeline shall be capable of locking in both directions on the lifeline.
8. Horizontal lifelines shall be designed, installed, and used, under the supervision of a qualified person, as part of a complete personal fall arrest system, which maintains a safety factor of at least two.
9. Lanyards and vertical lifelines shall have a minimum breaking strength of 5,000 pounds (22.2 kN).
10. Except as provided in paragraph (11) of this section when vertical lifelines are used, each employee shall be attached to a separate lifeline.

During the construction of elevator shafts, two employees may be attached to the same lifeline in the hoistway, provided both employees are working atop a false car that is equipped with guardrails; the strength of the lifeline is 10,000 pounds [5,000 pounds per employee attached] (44.4 kN); and all other criteria specified in this paragraph for lifelines have been met.

11. Lifelines shall be protected against being cut or abraded.
12. Self-retracting lifelines and lanyards which automatically limit free fall distance to 2 feet (0.61 m) or less shall be capable of sustaining a minimum tensile load of 3,000 pounds (13.3 kN) applied to the device with the lifeline or lanyard in the fully extended position.
13. Self-retracting lifelines and lanyards which do not limit free fall distance to 2 feet (0.61 m) or less, ripstitch lanyards, and tearing and deforming lanyards shall be capable of sustaining a minimum tensile load of 5,000 pounds (22.2 kN) applied to the device with the lifeline or lanyard in the fully extended position.
14. Ropes and straps (webbing) used in lanyards, lifelines, and strength components of body belts and body harnesses shall be made from synthetic fibers.
15. Anchorages used for attachment of personal fall arrest equipment shall be independent of any anchorage being used to support or suspend platforms and capable of supporting at least 5,000 pounds (22.2 kN) per employee attached, or shall be designed, installed, and used as follows:
 - a. As part of a complete personal fall arrest system which maintains a safety factor of at least two; and
 - b. Under the supervision of a qualified person.
16. Personal fall arrest systems, when stopping a fall, shall:
 - a. Limit maximum arresting force on an employee to 900 pounds (4 kN) when used with a body belt

- b. Limit maximum arresting force on an employee to 1,800 pounds (8 kN) when used with a body harness
- c. Be rigged such that an employee can neither free fall more than 6 feet (1.8 m), nor contact any lower level
- d. Bring an employee to a complete stop and limit maximum deceleration distance an employee travels to 3.5 feet (1.07 m)
- e. Have sufficient strength to withstand twice the potential impact energy of an employee free falling a distance of 6 feet (1.8 m), or the free fall distance permitted by the system, whichever is less.

Note: If the personal fall arrest system meets the criteria and protocols contained in FALL PROTECTION Appendix C of this Safety Manual, and if the system is being used by an employee having a combined person and tool weight of less than 310 pounds (140 kg), the system will be considered to be in compliance with the provisions of paragraph (16) of this section. If the system is used by an employee having a combined tool and body weight of 310 pounds (140 kg) or more, then the employer must appropriately modify the criteria and protocols of the Appendix to provide proper protection for such heavier weights, or the system will not be deemed to be in compliance with the requirements of paragraph (16) of this section.

17. The attachment point of the body belt shall be located in the center of the wearer's back. The attachment point of the body harness shall be located in the center of the wearer's back near shoulder level, or above the wearer's head.
18. Body belts, harnesses, and components shall be used only for employee protection (as part of a personal fall arrest system or positioning device system) and not to hoist materials.
19. Personal fall arrest systems and components subjected to impact loading shall be immediately removed from service and shall not be used again for employee protection until inspected and determined by a competent person to be undamaged and suitable for reuse.
20. The employer shall provide for prompt rescue of employees in the event of a fall or shall assure that employees are able to rescue themselves.
21. Personal fall arrest systems shall be inspected prior to each use for wear, damage and other deterioration, and defective components shall be removed from service.
22. Body belts shall be at least one and five-eighths ($1\frac{5}{8}$) inches (4.1 cm) wide.
23. Personal fall arrest systems shall not be attached to guardrail systems, nor shall they be attached to hoists except as specified in other subparts of this Part.
24. When a personal fall arrest system is used at hoist areas, it shall be rigged to allow the movement of the employee only as far as the edge of the walking/working surface.

POSITIONING DEVICE SYSTEMS

Positioning device systems and their use shall conform to the following provisions:

1. Positioning devices shall be rigged such that an employee cannot free fall more than 2 feet (.9 m).
2. Positioning devices shall be secured to an anchorage capable of supporting at least twice the potential impact load of an employee's fall or 3,000 pounds (13.3 kN), whichever is greater.
3. Connectors shall be drop forged, pressed or formed steel, or made of equivalent materials.
4. Connectors shall have a corrosion-resistant finish, and all surfaces and edges shall be smooth to prevent damage to interfacing parts of this system.
5. Connecting assemblies shall have a minimum tensile strength of 5,000 pounds (22.2 kN)

6. Dee-rings and snaphooks shall be proof-tested to a minimum tensile load of 3,600 pounds (16 kN) without cracking, breaking, or taking permanent deformation.
7. Snaphooks shall be sized to be compatible with the member to which they are connected to prevent unintentional disengagement of the snaphook by depression of the snaphook keeper by the connected member, or shall be a locking type snaphook designed and used to prevent disengagement of the snaphook by the contact of the snaphook keeper by the connected member. As of January 1, 1998, only locking type snaphooks shall be used.
8. Unless the snaphook is a locking type and designed for the following connections, snaphooks shall not be engaged:
 - a. Directly to webbing, rope or wire rope;
 - b. To each other;
 - c. To a dee-ring to which another snaphook or other connector is attached;
 - d. To a horizontal lifeline; or to depress the snaphook keeper and release itself.
 - e. To any object which is incompatibly shaped or dimensioned in relation to the snaphook such that unintentional disengagement could occur by the connected object being able to depress the snaphook keeper and release itself.
9. Positioning device systems shall be inspected prior to each use for wear, damage, and other deterioration, and defective components shall be removed from service.
10. Body belts, harnesses, and components shall be used only for employee protection (as part of a personal fall arrest system or positioning device system) and not to hoist materials.

Part 18 Appendix H: Drawings

ILLUSTRATION OF A CLIPPED END

Appendix H to Subpart R -- Double Connections: Illustration of a Clipped End Connection and a Staggered Connection: Non-Mandatory Guidelines for Complying with §1926.756(c)(1).

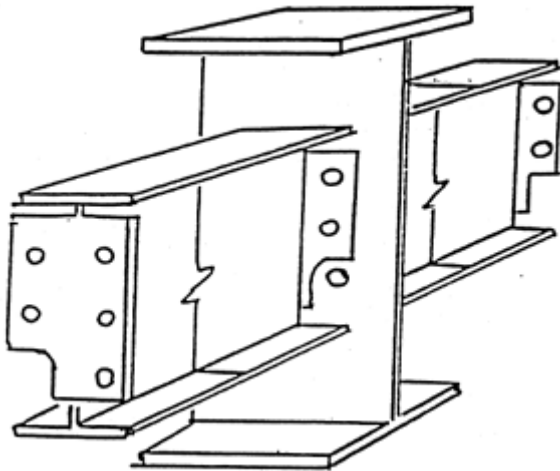

Clipped end connections are connection material on the end of a structural member which has a notch at the bottom and/or top to allow the bolt(s) of the first member placed on the opposite side of the central member to remain in place. The notch(es) fits around the nut or bolt head of the opposing member to allow the second member to be bolted up without removing the bolt(s) holding the first member.

STAGGERED CONNECTIONS

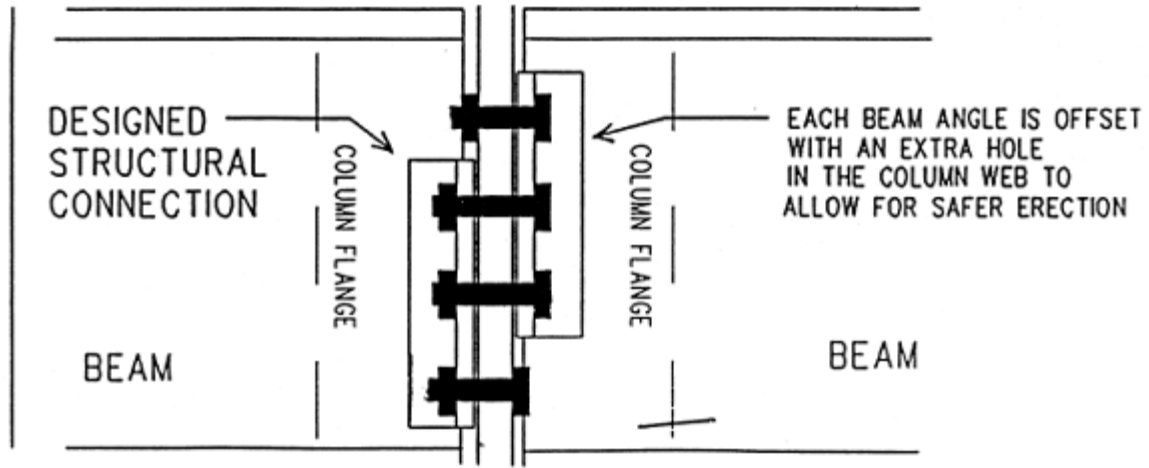

Staggered connections are connection material on a structural member in which all of the bolt holes in the common member web are not shared by the two incoming members in the final connection. The extra hole in the column web allows the erector to maintain at least a one bolt connection at all times while making the double connection.

Part 19: Welding & Cutting

INTRODUCTION

On School Construction Authority Project where Welding and Cutting is to take place, Federal OSHA Standards, New York City Department of Building Codes and School Construction Authority Safety Manual shall be implemented. The most stringent of these standards shall be applicable.

For additional details not covered in this subpart, applicable technical portions of American National Standards institute, Z49. 1-1967, Safety in Welding and Cutting, shall apply.



SCA GENERAL REQUIREMENTS

1. Any person welding or cutting is to hold a current Certificate of Fitness from the New York City Fire Department and must have such certification available on their person.
2. No storage of oxygen, acetylene or LPG gas is permitted on *occupied schools*. Only that which is needed for the shift's work activity is permitted, and shall be removed from the school premise at the end of each work shift.
3. Storage of compressed gases and LPG gas is permitted on *Line Projects* with a Permit for Storage and Use from the NYC Fire Department.
4. Storage of compressed gases and LPG gas on occupied schools where an addition is taking place is at the discretion of the Local Fire Department.
5. During all "hot work" activities a fire watch is to be present and so located in the area(s) to effectively monitor the situation. "Hot work is defined as any work that can give off a source of ignition, or that in any way can start a fire.
6. A fire watch is to carry a current Certificate of Fitness from the New York City Fire Department and have such certificate available on their person.
7. Prior to any "hot work" activity, 48 hour notification shall be made to the SCA Safety Unit.

CYLINDERS

Transporting, Moving, and Storing Compressed Gas Cylinders

1. Valve protection caps shall be in place and secured.
2. When cylinders are hoisted, they shall be secured on a cradle, sling board, or pallet. They shall not be hoisted or transported by means of magnets or choker slings.
3. Cylinders shall be moved by tilting and rolling them on their bottom edges. They shall not be intentionally dropped, struck, or permitted to strike each other violently.
4. When cylinders are transported by powered vehicles, they shall be secured in a vertical position.
5. Valve protection caps shall not be used for lifting cylinders from one vertical position to another. Bars shall not be used under valves or valve protection caps to pry cylinders loose when frozen. Warm, not boiling, water shall be used to thaw cylinders loose.
6. Unless cylinders are firmly secured on a special carrier intended for this purpose, regulators shall be removed and valve protective caps put in place before cylinders are moved.
7. A suitable cylinder truck, chain, or other steadying device shall be used to keep cylinders from being knocked over while in use.
8. When work is finished, when cylinders are empty, or when cylinders are moved at any time, the cylinder valve shall be closed.
9. Compressed gas cylinders shall be secured in an upright position at all times except, if necessary, for short periods of time while cylinders are actually being hoisted or carried.
10. Oxygen cylinders in storage shall be separated from fuel gas cylinders or combustible materials (especially oil or grease), a minimum distance of 20 feet or by a noncombustible barrier at least 5 feet high having a fire resistance rating of at least on half-hours.
11. Inside of building, cylinders shall be stored in a well protected, well ventilated, dry location, at least 20 feet from highly combustible materials such as oil or excelsior. Cylinders should be stored in definitely assigned places away from elevators, stairs, or gangways. Assigned storage places shall be located where cylinders will not be knocked over or damaged by passing or falling objects, or subject to tampering by unauthorized persons. Cylinders shall not be kept in unventilated enclosures such as lockers and cupboards.

Placing Cylinders

1. Cylinders whether full or empty, shall not be taken into confined spaces.
2. No person other than the gas supplier shall attempt to mix gases in a cylinder. No one except the owner of the cylinder or person authorized by him shall refill a cylinder. No one shall use a cylinder's contents for purposes other than those intended by the supplier. All cylinders used shall meet the Department of Transportation requirements.
3. No damaged or defective cylinder shall be used.

FUEL GAS

Use of Fuel Gas

The employer shall thoroughly instruct employees in the safe use of fuel gas, as follows:

1. Before a regulator to a cylinder valve is connected the valve shall be opened slightly and closed immediately. (This action is generally termed “cracking” and is intended to clear the valve of dust or dirt that might otherwise enter the regulator.) The person cracking the valve shall stand to one side of the outlet, not in front of it. The valve of a fuel gas cylinder shall not be cracked where the gas would reach welding work, sparks, flame or other possible sources of ignition.
2. The cylinder valve shall always be opened slowly to prevent damage to the regulator. For quick closing, valves on fuel gas cylinders shall not be opened more than 1 and ½ turns. When a special wrench is required, it shall be left in position on the stem of the valve while the cylinder is in use so that the fuel gas flow can be shut off quickly in case of an emergency. In the case of manifold or coupled cylinders, at least one such wrench shall always be available for immediate use. Nothing shall be placed on top of a fuel gas cylinder, when in use, which may damage the safety device or interfere with the quick closing of the valve.
3. Fuel gas shall not be used from cylinders through torches or other devices, which are equipped with shutoff valves without reducing the pressure through a suitable regulator, attached to the cylinder valve or manifold.
4. Before a regulator is removed from a cylinder valve, the cylinder valve shall always be closed and the gas released from the regulator.
5. If, when the valve on a fuel gas cylinder is opened, there is found to be a leak around the valve stem, the valve shall be closed and the gland nut tightened. If this action does not stop the leak, the use of the cylinder shall be discontinued. And it shall be properly tagged and removed from the work area. In the event that fuel gas should leak from the cylinder valve, rather than from the valve stem and the gas cannot be shut off, the cylinder shall be properly tagged and removed from the work area. If a regulator attached to a cylinder valve will effectively stop a leak through the valve seat, the cylinder need not be removed from the work area.
6. If a leak should develop at a fuse plug or other safety device, the cylinder shall be removed from the work area.

Fuel Gas and Oxygen Manifolds

1. Fuel gas and oxygen manifolds shall bear the name of the substance they contain in letters at least 1 inch high which shall be either painted on the manifold or on a sign permanently attached to it.
2. Fuel gas and oxygen manifolds shall be placed in safe, well ventilated, and accessible locations. They shall not be located within enclosed spaces.
3. Manifold hose connections, including both ends of the supply hose that lead to the manifold, shall be such that the hose can not be interchanged between fuel gas and oxygen manifolds and supply header connections. Adapters shall not be used to permit the interchange of hose. Hose connections shall be kept free of grease and oil.
4. When not in use, manifold and header hose connections shall be capped.
5. Nothing shall be placed on top of a manifold, when in use, which will damage the manifold or interfere with the quick closing of the valves.

HOSE

1. Fuel gas hose and oxygen hose shall be easily distinguishable from each other. The contrast may be made by different colors or by surface characteristics readily distinguishable by the sense of touch. Oxygen and fuel gas hoses shall not be interchangeable. A single hose having more than one gas passage shall not be used.
2. When parallel sections of oxygen and fuel gas hose are taped together, not more than 4 inches out of 12 inches shall be covered by tape.
3. All hose in use, carrying acetylene, oxygen, natural or manufactured fuel gas, or any gas or substance which may ignite or enter into combustion, or be in any way harmful to employees, shall be inspected at the beginning of each working shift. Defective hose shall be removed from service.

4. Hose which has been subject to flashback or which shows evidence of severe wear or damage shall be tested to twice the normal pressure to which it is subject, but in no case less than 300 psi. Defective hose, or hose in doubtful condition, shall not be used.
5. Hose couplings shall be of the type that cannot be unlocked or disconnected by means of a straight pull without rotary motion.
6. Boxes used for the storage of gas hose shall be ventilated.
7. Hoses, cables, and other equipment shall be kept clear of passageways, ladders and stairs.

TORCHES

1. Clogged torch tip openings shall be cleaned with suitable cleaning wires, drills, or other devices designed for such purpose.
2. Torches in use shall be inspected at the beginning of each working shift for leaking shutoff valves, hose couplings, check valves and tip connections. Defective torches shall not be used.
3. Torches shall be lighted by friction lighters or other approved devices, and not by matches or from hot work.

REGULATORS AND GAUGES

Oxygen and fuel gas pressure regulators, including their related gauges, shall be in proper working order while in use.

OIL AND GREASE HAZARDS

Oxygen cylinders and fittings shall be kept away from oil or grease. Cylinders, cylinder caps and valves, couplings, regulators, hose and apparatus shall be kept free from oil or greasy substances and shall not be handled with oily hands or gloves. Oxygen shall not be directed at oily surfaces, greasy clothes, or within a fuel oil or other storage tank or vessel.

ARC WELDING AND CUTTING

Manual Electrode Holders

1. Only manual electrode holders which are specifically designed for arc welding and cutting, and are of a capacity capable of safety handling the maximum rated current required by the electrodes, shall be used.
2. Any current carrying parts passing through the portion of the holder which the arc welder or cutter grips in his hand, and the outer surfaces of the jaws of the holder, shall be fully insulated against the maximum voltage encountered to ground.

Welding Cables and Connectors

1. All arc welding and cutting cables shall be of the completely insulated, flexible type, capable of handling the maximum current requirements of the work in progress, taking into account the duty cycle under which the arc welder or cutter is working.
2. Only cable free from repair or splices for a minimum distance of 10 feet from the cable end to which the electrode holder is connected shall be used, except that cables with standard insulated connectors or with splices whose insulating quality is equal to that of the cable are permitted.
3. When it becomes necessary to connect or splice lengths of cable one to another, substantial insulated connectors of a capacity at least equivalent to that of the cable shall be used. If connections are effected by means of cable lugs, they

shall be securely fastened together to give good electrical contact and the exposed metal parts of the lugs shall be completely insulated.

4. Cables in need of repair shall not be used. When a cable, other than the cable lead referred to in item #2 of this section, becomes worn to the extent of exposing bare conductors, the portion thus exposed shall be protected by means of rubber and friction tape or other equivalent insulation.

Ground Returns and Machine Grounding

1. A ground return cable shall have a safe current carrying capacity equal to or exceeding the specified maximum output capacity of the arc welding or cutting unit which it services. When a single ground return cable services more than one unit, its current carrying capacity shall be equal to or exceed the total specified maximum output capacities of all the units which it services.
2. Pipelines containing gases or flammable liquids, or conduits containing electrical circuits, shall not be used as a ground return. For welding on natural gas pipelines, the technical portions of regulations issued by the Department of Transportation, Office of Pipeline Safety, Minimum Federal Safety Standards for Gas Pipelines, shall apply.
3. When a structure or pipeline is employed as a ground return circuit, it shall be determined that the required electrical contact exists at all joints. The generation of an arc, sparks, or heat at any point shall cause rejection of the structures as a ground circuit.
4. When a structure or pipeline is continuously employed as a ground return circuit, it shall be determined that the required electrical contact exists at all joints. The generation of an arc, sparks, or heat at any point shall cause rejection of the structures as a ground circuit.
5. When a structure or pipeline is continuously employed as a ground return circuit, all joints shall be bonded, and periodic inspections shall be conducted to ensure that no condition of electrolysis or fire hazard exists by virtue of such use.
6. The frames of all arch welding and cutting machines shall be grounded either through a third wire in the cable containing the circuit conductor or through a separate wire which is grounded at the source of the current. Grounding circuits, other than by means of the structure, shall be checked to ensure that the circuit between the ground and the grounded power conductor has resistance low enough to permit sufficient current to flow to cause the fuse or circuit breaker to interrupt the current.
7. All ground connections shall be inspected to ensure that they are mechanically strong and electrically adequate for the required current.

Operating Instructions

Employers shall instruct employees in the safe means of arc welding and cutting as follows:

1. When electrode holders are to be left unattended, the electrodes shall be removed and the holders shall be so placed or protected that they can not make electrical contact with employees or conducting objects.
2. Hot electrode holders shall not be dipped in water; to do so may expose the arc welder or cutter to electric shock.
3. When the arc welder or cutter has occasion to leave his work or to stop work for any appreciable length of time, or when the arc welding or cutting machine is to be moved, the power supply switch to the equipment shall be opened.
4. Any faulty or defective equipment shall be reported to the supervisor.

Shielding

Whenever practicable, all arc welding and cutting operations shall be shielded by noncombustible or flameproof screens which will protect employees and other persons working in the vicinity from the direct rays of the arc.

Fire Prevention

1. When practical, objects to be welded, cut, or heated shall be moved to a designated safe location or, if the objects to be welded, cut or heated can not be readily moved, all movable fire hazards in the vicinity shall be taken to a safe place, or otherwise protection.
2. If the object to be welded, cut or heated can not be moved and if all the fire hazards can not be removed, positive means shall be taken to confine the heat, sparks, and slag, and to protect the immovable fire hazards from them.
3. No welding, cutting or heating shall be done where the application of flammable points or the presence of other flammable compounds, or heavy dust concentrations creates a hazard.
4. Suitable fire extinguishing equipment shall be immediately available in the work area and shall be maintained in a state of readiness for instant use.
5. When the welding, cutting or heating operation is such that normal fire prevention precautions are not sufficient, additional personnel shall be assigned to guard against fire while the actual welding, cutting, or heating operation is being performed, and for a sufficient period of time after completion of the work to ensure that no possibility of fire exists. Such personnel shall be instructed as to the specific anticipated fire hazards and how the firefighting equipment provided is to be used.
6. When welding, cutting or heating is performed on walls, floors, and ceilings, since direct penetration of sparks or heat transfer may introduce a fire hazard to an adjacent area, the same precautions shall be taken on the opposite side as are taken on the side on which the welding is being performed.
7. For the elimination of possible fire in enclosed spaces as a result of gas escaping through leaking or improperly closed torch valves, the gas supply to the torch shall be positively shut off at some point outside the enclosed space whenever the torch is not to be used or whenever the torch is left unattended for a substantial period of time, such as during the lunch period. Overnight and at the change of shifts, the torch and hose shall be removed from the confined space. Open end fuel gas and oxygen hoses shall be immediately removed from enclosed spaces when they are disconnected from the torch or other gas-consuming device.
8. Except when their contents are being removed or transferred, drums, pails, and other containers which contain or have contained flammable liquids shall be kept closed. Empty containers shall be removed to a safe area apart from hot work operations or open flames.
9. Drums, containers, or hollow structures which have contained toxic or flammable substances shall, before welding, cutting or heating is undertaken on them, either be filled with water or thoroughly cleaned of such substances and ventilated and tested. For welding, cutting and heating on steel pipelines containing natural gas, the pertinent portions of regulations issued by the Department of Transportation, Office of Pipeline Safety, Minimum Federal Safety Standards for Gas Pipelines, shall apply.
10. Before heat is applied to a drum, container, or hollow structure, a vent or opening shall be provided for the release of any built up pressure during the application of heat.

VENTILATION AND PROTECTION IN WELDING, CUTTING AND HEATING

Mechanical Ventilation

1. Mechanical ventilation shall consist of either general mechanical ventilation systems or local exhaust systems.
2. General mechanical ventilation shall be of sufficient capacity and so arranged as to produce the number of air changes necessary to maintain welding fumes and smoke within safe limits.
3. Local exhaust ventilation shall consist of freely movable hoods intended to be placed by the welder or burner as close as practicable to the work. This system shall be of sufficient capacity and so arranged as to remove fumes and smoke at the source and keep the concentration of them in the breathing zone within safe limits.

4. Contaminated air exhausted from a working space shall be discharged into the open air or otherwise clear of the source of intake air.
5. All air replacing that withdrawn shall be clean and respirable.
6. Oxygen shall not be used for ventilation purposes, comfort cooling, blowing dust from clothing, or for cleaning the work area.

Welding, Cutting and Heating In Confined Spaces

1. Except as provided in the next two paragraphs of this section, either general mechanical or local exhaust ventilation meeting the requirements of #1 in Mechanical Ventilation, shall be provided whenever welding, cutting or heating is performed in a confined space.
2. When sufficient ventilation cannot be obtained without blocking the means of access, employees in the confined space shall be protected by air line respirators, and an employee on the outside of such a confined space shall be assigned to maintain communication with those working within it and to aid them in an emergency. All work within a Confined Space shall be performed in accordance with the Confined Space Entry Section of this Safety Manual

Part 19 Form: Hot Work Permit Procedure

HOT WORK PERMIT PROCEDURE

Hot work permit means the employer’s written authorization to perform operations (General Contractor, or sub-contractor performing the work) (for example, riveting, welding, cutting, burning and heating) capable of providing a source of ignition. OSHA §1910.146 (b). The permit is issued by the employer or competent person or welder if competent person.

Items in Hot Work Permit:

Circle type of Hot Work: Welding/Blow Torching Hot Asphalt/Roofing Brazing/Soldering
Welders _____ License Review _____ Exp Date _____
*Fire Watch _____ Certificate of Fitness Review _____ Exp Date _____
Date of Work _____ Time _____ Location _____
Inspection/evaluation of Hazards by Supervision/Competent Person _____

Hazard Evaluation or Assessment

Fire Hazard _____
Controls Implemented _____
General Inspection of Welding area:
Fall Hazards _____
Controls Implemented _____
Confined Space (if so, must comply with OSHA §1910.146
Other Hazards not mentioned here _____
Notification to Employer _____
Permit Accepted or Rejected and Reason _____
Person Issuing Hot Work Permit/Competent Person/Superintendent Date _____

Print Name: _____ Signature: _____

Additional Comments:

*Fire Watch may be needed at each location hot work is taking place simultaneously and shall have no other duties.

Glossary

A

Acceptable

An installation or equipment is acceptable to the Assistant Secretary of Labor.

There are three areas of acceptance:

If it is accepted, or certified, or listed, or labeled, or otherwise determined to be safe by a qualified testing laboratory capable of determining the suitability of materials and equipment for installation and use in accordance with this standard

With respect to an installation or equipment of a kind which no qualified testing laboratory accepts, certifies, lists, labels, or determines to be safe, if it is inspected or tested by another Federal agency, or by a State, municipal, or other local authority responsible for enforcing occupational safety provisions of the National Electrical Code, and found in compliance with those provisions

With respect to custom-made equipment or related installations that are designed, fabricated for, and intended for use by a particular customer, if it is determined to be safe for its intended use by its manufacturer on the basis of test data which the employer keeps and makes available for inspection to the Assistant Secretary and his authorized representatives.

Accepted

Installation:

An installation is accepted if it has been inspected and found to be safe by a qualified testing laboratory.

See Qualified Testing Laboratory

Engineering Practices:

Requirements, which are compatible with standards of practice required by a registered professional engineer.

Accessible Equipment

Admitting close approach; not guarded by locked doors, elevation, or other effective means.

See Readily Accessible

Accessible Wiring Methods

Capable of being removed or exposed without damaging the building structure or finish, or not permanently closed in by the structure or finish of the building.

	<i>See</i> Concealed and Exposed
Actual Slope	Slope to which an excavation face is excavated.
Adjustable Suspension Scaffold	Suspension scaffold means a suspension scaffold equipped with a hoist(s) that can be operated by an employee(s) on the scaffold.
Aluminum Hydraulic Shoring	Pre-engineered shoring system comprised of aluminum hydraulic cylinders (crossbraces) used in conjunction with vertical rails (uprights) or horizontal rails (wales). Such system is designed specifically to support the sidewalls of an excavation and prevent cave-ins.
Ampacity	The current in amperes a conductor can carry continuously under the conditions of use without exceeding its temperature rating.
Anchorage	A secure point of attachment for lifelines, lanyards, or deceleration devices.
Anchored Bridging	Steel joist bridging is connected to a bridging terminus point.
ANSI	American National Standards Institute
Appliances	Utilization equipment, generally other than industrial, normally built in standardized sizes or types, which is installed or connected as a unit to perform one or more functions.
Approved	<p><i>Electrical Provisions:</i> What is acceptable to the Assistant Secretary of Labor, as defined by the Assistant Secretary of Labor for Occupational Safety and Health.</p> <p><i>Fire Provisions:</i> Equipment that has been listed or approved by a nationally recognized testing laboratory such as Factory Mutual Engineering Corp., and Underwriters' Laboratories, Inc.; or Federal agencies such as MSHA, OSHA and the US Coast Guard which issues approvals for such equipment.</p>
Attachment Plug	<p><i>See</i> Qualified Testing Laboratory</p> <p>A device which, by insertion in a receptacle, establishes connection between the conductors of the attached flexible cord and the conductors connected permanently to the receptacle.</p>
Automatic	<p>Self-acting, operating by its own mechanism when actuated by some impersonal influence</p> <p> <i>Example:</i> A change in current strength, pressure, temperature, or mechanical configuration.</p>
B	
Bare Conductor	<i>See</i> Conductor

Barricade	An obstruction to deter the passage of persons or vehicles.
Bearer	Horizontal transverse scaffold member (which may be supported by ledgers or runners) upon which the scaffold platform rests and which joins scaffold uprights, posts, poles, and similar members.
Bell-Bottom Pier Hole	Type of shaft or footing excavation, the bottom of which is made larger than the cross section above to form a belled shape.
Benching	Method of protecting employees from cave-ins by excavating the sides of an excavation to form one or a series of horizontal levels or steps, usually with vertical or near-vertical surfaces between levels.
Boatswains' Chair	Single-point adjustable suspension scaffold consisting of a seat or sling designed to support one employee in a sitting position.
Body Belt	A strap with means both for securing it about the waist and for attaching it to a lanyard, lifeline, or deceleration device will prevent a worker from falling.
Body Harness	Straps that may be secured about the employee in a manner that will distribute the fall arrest forces over at least the thighs, pelvis, waist, chest and shoulders with means for attaching it to other components of a personal fall arrest system.
Bolted Diagonal Bridging	Diagonal bridging that is bolted to a steel joist or joists.
Brace	Rigid connection that holds one scaffold member in a fixed position with respect to another member, or to a building structure.
Bricklayers' Square Scaffold	Supported scaffold composed of framed squares which support a platform.
Bridging Clip	Device that is attached to the steel joist to allow the bolting of the bridging to the steel joist.
Bridging Terminus Point	Wall, beam, tandem joists (with all bridging installed and a horizontal truss in the plane of the top chord) or other element at an end or intermediate point(s) of a line of bridging that provides an anchor point for the steel joist bridging.
Buckle	Any device for holding the body belt or body harness closed around the employee's body.
Building	A structure which stands alone or which is cut off from adjoining structures by firewalls with all openings therein protected by approved fire doors.
Bull Float	A tool used to spread out and sooth concrete.
C	
Cabinet	An enclosure designed either for surface or flush mounting, and provided with a frame, mat, or trim in which a swinging door or doors are or may be hung.

Cap	<i>See</i> Attachment Plug
Capital Improvement Project (CIP)	A smaller project consisting of one capital category, such as roof and boiler replacements, electrical work, security systems, room conversions, and transportable classrooms. CIP projects do not have their own budgets; many CIP projects will be funded by one CP.
Carpenters' Bracket Scaffold	Supported scaffold consisting of a platform supported by brackets attached to building or structural walls.
Catenary Scaffold	Suspension scaffold consisting of a platform supported by two essentially horizontal and parallel ropes attached to structural members of a building or other structure. Additional support may be provided by vertical pickups.
Cave-In	Separation of a mass of soil or rock material from the side of an excavation, or the loss of soil from under a trench shield or support system, and its sudden movement into the excavation, either by falling or sliding, in sufficient quantity so that it could entrap, bury, or otherwise injure and immobilize a person.
Cemented Soil	Soil in which a chemical agent, such as calcium carbonate, holds the particles together such that a hand-size sample cannot be crushed into powder or individual soil particles by finger pressure.
Chicken Ladder	<i>See</i> Coupler
Chimney Hoist	Multi-point adjustable suspension scaffold used to provide access to work inside chimneys. (See "Multi-point adjustable suspension scaffold".)
Choker	Wire rope or synthetic fiber rigging assembly that is used to attach a load to a hoisting device.
Cleat	Structural block used at the end of a platform to prevent the platform from slipping off its supports. Cleats are also used to provide footing on sloped surfaces such as crawling boards or as a ladder crosspiece of a rectangular cross section placed on edge upon which a person may step while ascending or descending a ladder.
Close Container	Container so sealed by means of a lid or other device that neither liquid nor vapor will escape from it at ordinary temperatures.
Cohesive Soil	Clay (fine grained soil), or soil with a high clay content, which has cohesive strength. Cohesive soil does not crumble, can be excavated with vertical sideslopes, and is plastic when moist. Cohesive soil is hard to break up when dry, and exhibits significant cohesion when submerged. Cohesive soils include clayey silt, sandy clay, silty clay, clay and organic clay.
Cold Forming	Process of using press brakes, rolls, or other methods to shape steel into desired cross sections at room temperature.
Column	Load-carrying vertical member that is part of the primary skeletal framing system. Columns do not include posts.
Combustible Liquid	Any liquid having a flash point at or above 100 degrees F (38 degrees C) and below 200 degrees F (93.4 degrees C).

Combustion	Any chemical process that involves oxidation sufficient to produce light or heat.
Competent person	One who is capable of identifying existing and predictable hazards in the surroundings or working conditions which are unsanitary, hazardous, or dangerous to employees, and who has authorization to take prompt corrective measures to eliminate them.
Concealed	Rendered inaccessible by the structure or finish of the building. Wires in concealed raceways are considered concealed; even through they may become accessible by withdrawing them.
Conductor	<i>See</i> Accessible Wiring Methods Bare: A conductor having no covering or electrical insulation whatsoever.
Confined Space	Any space having a limited means of egress, which is subject to the accumulation of toxic or flammable contaminants or has an oxygen deficient atmosphere. Confined spaces are large enough and configured so that an employee can bodily enter and perform the assigned work; but they not designed for continuous occupancy. E <i>Example:</i> Included, but not limited to: storage tanks, process vessels, bins, boilers, ventilation or exhaust ducts, sewers, underground utility vaults, tunnels, pipelines, and open top spaces more than 4 feet in depth such as pits, tubs, vaults, and vessels.
Confined Space Entry	Any action resulting in any part of the worker's face breaking the plane of any opening of the confined space, and includes any ensuing work activities inside the confined space.
Confined Space, Permit Required	<i>See</i> Permit Required Confined Space
Connector	Means a device which is used to couple (connect) parts of the personal fall arrest system and positioning device systems together. It may be an independent component of the system, such as a carabiner, or it may be an integral component of part of the system (such as a buckle or dee-ring sewn into a body belt or body harness, or a snap-hook spliced or sewn to a lanyard or self-retracting lanyard). Employee who, working with hoisting equipment, is placing and connecting structural members and/or components
Constructibility	Ability to erect structural steel members in accordance with subpart R without having to alter the over-all structural design.
Construction Load	For joist erection, any load other than the weight of the employee(s), the joists and the bridging bundle.
Contaminant	Any material, which by reason of its action upon, within, or to a person is likely to cause physical harm

Continuous Run Scaffold	Two-point or multi-point adjustable suspension constructed using a series of interconnected braced scaffold members or supporting structures erected to form a continuous scaffold.
Contract	A written agreement by and between the owner and a contractor/subcontractor or between a subcontractor and their subcontractor(s).
Contractor	Any individual, firm or corporation who performs work with the consent of the SCA/GC and CM.
Controlled Decking Zone (CDZ)	Area in which certain work (for example, initial installation and placement of metal decking) may take place without the use of guardrail systems, personal fall arrest systems, fall restraint systems, or safety net systems and where access to the zone is controlled.
Controlled Load Lowering	Lowering a load by means of a mechanical hoist drum device that allows a hoisted load to be lowered with maximum control using the gear train or hydraulic components of the hoist mechanism. Controlled load lowering requires the use of the hoist drive motor, rather than the load hoist brake, to lower the load.
Controlling Contractor	Prime contractor, general contractor, construction manager or any other legal entity which has the overall responsibility for the construction of the project -- its planning, quality and completion.
Coupler	Device for locking together the tubes of a tube and coupler scaffold.
Crawling Board	Supported scaffold consisting of a plank with cleats spaced and secured to provide footing, for use on sloped surfaces such as roofs.
Critical Lift	Lift that exceeds 75% of the rated capacity of the crane or derrick or requires the use of more than one cranes or derricks.
Critical Picks	<p>Rigging operations involving loads that:</p> <ul style="list-style-type: none"> are at or above 95% of approved rated capacity of the crane or rigging equipment, are asymmetrical or have a wind sail area exceeding 500 square feet, may present a problem because of clearance, drift, or other interference, are fragile or of thin shell construction and are not provided with standard rigging ears, require multiple cranes or derricks (tandem picks), or require out of the ordinary rigging equipment, methods or setup.
Cross Braces	Horizontal members of a shoring system installed perpendicular to the sides of the excavation, the ends of which bear against either uprights or wales.

D

Dangerous Equipment	Equipment (such as pickling or galvanizing tanks, degreasing units, machinery, electrical equipment, and other units) which, as a result of form or function, may be hazardous to employees who fall onto or into such equipment.
Deceleration Device	Any mechanism, such as a rope grab, rip-stitch lanyard, specially woven lanyard, tearing or deforming lanyards, or automatic self-retracting lifelines/lanyards; which dissipates a substantial amount of energy during a fall arrest or otherwise limits the energy imposed on an employee during fall arrest.
Deceleration Distance	The additional vertical distance a falling employee travels, excluding lifeline elongation and free fall distance, before stopping, from the point at which the deceleration device begins to operate. It is measured as the distance between the location of an employee's body belt or body harness attachment point at the moment of activation (at the onset of fall arrest forces) of the deceleration device during a fall, and the location of that attachment point after the employee comes to a full stop.
Decking Hole	Gap or void more than 2 inches (5.1 cm) in its least dimension and less than 12 inches (30.5 cm) in its greatest dimension in a floor, roof or other walking/working surface. Pre-engineered holes in cellular decking (for wires, cables, etc.) are not included in this definition.
Derrick Floor	Elevated floor of a building or structure that has been designated to receive hoisted pieces of steel prior to final placement.
Distress	Soil in a condition where a cave-in is imminent or is likely to occur. Distress is evidenced by such phenomena as the development of fissures in the face of or adjacent to an open excavation; the subsidence of the edge of an excavation; the slumping of material from the face or the bulging or heaving of material from the bottom of an excavation; the spalling of material from the face of an excavation; and ravelling, i.e., small amounts of material such as pebbles or little clumps of material suddenly separating from the face of an excavation and trickling or rolling down into the excavation.
Double Cleat Ladder	Ladder similar in construction to a single cleat ladder, but with a center rail to allow simultaneous two way traffic for employees ascending or descending.
Double Connection	Attachment method where the connection point is intended for two pieces of steel which share common bolts on either side of a central piece.
Double Connection Seat	Structural attachment that, during the installation of a double connection, supports the first member while the second member is connected.
Double Pole	Supported scaffold consisting of platforms resting on cross beams supported by ledgers and double row of uprights independent of support from any structure.  Exception: Ties, guys, and braces are not used to support double poles.

E

Dry Soil	Soil that does not exhibit visible signs of moisture content.
Emergency Work	Work to be done immediately to correct a hazardous condition.
Employer	A contractor, subcontractor, or sub-subcontractor(s).
Enclosed Space	A confined space.
Equivalent	<i>See</i> Confined Space
Erection Bridging	Bolted diagonal bridging that is required to be installed prior to releasing the hoisting cables from the steel joists.
Excavation	Any man-made cut, cavity, trench, or depression in an earth surface, formed by earth removal.
Exposed	<p>Live Parts: Capable of being inadvertently touched or approached nearer than a safe distance by a person. It is applied to parts not suitably guarded, isolated, or insulated.</p> <p><i>See</i> Acceptable and Concealed</p> <p>Wiring Methods: On or attached to the surface or behind panels designed to allow access.</p> <p><i>See</i> Accessible Wiring Methods</p> <p>1926.408(d) Communications Systems: Where the circuit is in such a position that in case of failure of supports or insulation, contact with another circuit may result.</p>
Exposed Power	Electrical power lines that are accessible to employees and are not shielded from contact. Such lines do not include extension cords or power tool cords.
Extension Trestle Ladder	Self-supporting portable ladder, adjustable in length, consisting of a trestle ladder base and a vertically adjustable extension section, with a suitable means for locking the ladders together.
Eye	<i>See</i> Eye Splice
Eye Splice	Loop with or without a thimble at the end of a wire rope.

F

Fabricated Decking	Manufactured platforms made of wood (including laminated wood, and solid sawn wood planks), metal or other materials.
Fabricated Frame Scaffold	Scaffold consisting of a platform(s) supported on fabricated end frames with integral posts, horizontal bearers, and intermediate members.
Fabricated Planking	<i>See Fabricated Decking</i>
Faces or Sides	Vertical or inclined earth surfaces formed as a result of excavation work.
Failure	Load refusal, breakage, or separation of component parts. Load refusal is the point where the ultimate strength is exceeded and the structural members lose their ability to carry the loads.
Fall Restraint System	Fall protection system that prevents the user from falling any distance. The system is comprised of either a body belt or body harness, along with an anchorage, connectors and other necessary equipment. The other components typically include a lanyard, and may also include a lifeline and other devices.
Final Interior Perimeter	Perimeter of a large permanent open space within a building such as an atrium or courtyard. This does not include openings for stairways, elevator shafts, etc.
Fire Brigade	Organized group of employees that are knowledgeable, trained and skilled in the safe evacuation of employees during emergency situations and in assisting in fire fighting operations.
Fire Resistance	Resistant to fire for a specified time and under conditions of a standard heat intensity, it will not fail structurally and will not permit the side away from the fire to become hotter than a specified temperature. For purposes of this part, fire resistance shall be determined by the Standard Methods of Fire Tests of Building Construction and Materials, NFPA, 251.
Fire Guard	A person holding a certificate of fitness for such purpose, who is trained in and responsible for maintaining a fire watch and performing such fire safety duties as may be prescribed by the commissioner.
Fissured	Soil material that has a tendency to break along definite planes of fracture with little resistance, or a material that exhibits open cracks, such as tension cracks, in an exposed surface.
Fixed Ladder	Ladder that can not be readily moved or carried because it is an integral part of a building or structure. A side step fixed ladder is a fixed ladder that required a person getting off at the top to step to the side of the ladder side rails to reach the landing. A through fixed ladder is a fixed ladder that requires a person getting off at the top to step between the side rails of the ladder to reach the landing.
Flammable	Capable of being easily ignited, burning intensely or having a rapid rate of flame spread.

Flammable Liquids	Any liquid having a flash point below 140 degrees and having a vapor pressure not exceeding 40 pounds per square inch (absolute) at 100 degrees F.
Flash Point	<p>Temperature at which a liquid gives off vapor sufficient to form an ignitable mixture with the air near the surface of the liquid or within the vessel used as determined by appropriate test procedure and apparatus as specified below.</p> <p>The flash point of liquids having a viscosity less than 45 Saybolt universal Second(s) at 100 degrees F (37.8 degrees C) and a flash point below 175 degrees F (79.4 degrees C) shall be determined in accordance with Standard Method of test for Flash Point by the Tag Closed Tester, ASTM D56.</p> <p>The flash point of liquids having a viscosity of 45 Saybolt universal Second(s) or more at 175 degrees F (79.4 degrees C) or higher shall be determined in accordance with the Standard Method of Test for Flash Point the Pensky Martens Closed Tester, ASTM D-93.</p>
Float Scaffold	Suspension scaffold consisting of braced platform resting on two parallel bearers and hung from overhead supports by ropes of fixed length.
Form Scaffold	Supported scaffold consisting of a platform supported by bracket attached to formwork.
Form Work	The total system of support for freshly placed or partially cured concrete, including the mold or sheeting (form) that is in contact with the concrete as well as all supporting members including shores, re-shores, hardware, braces, and related hardware.
Free Fall	The act of falling before a personal fall arrest system begins to apply force to arrest the fall.
Free Fall Distance	<p>Vertical displacement of the fall arrest attachment point on the employee's body belt or body harness between onset of the fall and just before the system begins to apply force to arrest the fall.</p> <p>This distance excludes deceleration distance, and lifeline/lanyard elongation, but includes any deceleration device slide distance or self-retracting lifeline/lanyard extension before they operate and fall arrest forces occur.</p>

G

General Contractor (GC)	Prime contractor performing the construction work.
General Contractor Safety Coordinator	Employee of the GC and responsible to coordinate project safety with all contractors and subcontractors of any tier. The project safety coordinator works with the GC and insurance company safety personnel.
Girt	In systems-engineered metal buildings a "Z" or "C" shaped member formed from sheet steel spanning between primary framing and supporting wall material.

	<p>Granular Soil Gravel, sand, or silt (coarse grained soil) with little or no clay content. Granular soil has no cohesive strength. Some moist granular soils exhibit apparent cohesion. Granular soil cannot be molded when moist and crumbles easily when dry.</p>
	<p>Ground A conducting connection, whether intentional or accidental, between an electrical circuit or equipment and the earth, or to some conducting body that serves in place of the earth.</p>
<p>Ground-Fault Circuit Interrupter (GCFI)</p>	<p>A device for the protection of personnel that functions to de-energize a circuit or portion thereof within an established period of time when a current to ground exceeds some predetermined value that is less than that required to operate the over current protective device of the supply circuit.</p>
	<p>Guarded Covered, shielded, fenced, enclosed, or otherwise protected by means of suitable covers, casings, barriers, rails, screens, mats, or platforms to remove the likelihood of approach to a point of danger or contact by persons or objects.</p>
<p>Guardrail System</p>	<p>Vertical barrier consisting of, but not limited to, top rails, mid rails, and posts, erected to prevent employees from falling off a scaffold platform or walkway to lower levels.</p>
<p>H</p>	
<p>Handrail</p>	<p>Rail used to provide employees with a handhold for support.</p>
<p>Hazardous Atmosphere</p>	<p>Atmosphere which by reason of being explosive, flammable, poisonous, corrosive, oxidizing, irritating, oxygen deficient, toxic, or otherwise harmful, may cause death, illness, or injury.</p>
<p>Headache Ball</p>	<p>Weighted hook that is used to attach loads to the hoist load line of the crane.</p>
<p>Hoist</p>	<p>Manual or power-operated mechanical device to raise or lower a suspended scaffold.</p>
<p>Hoist, Power Operated</p>	<p>A hoist which is powered by other than human energy.</p>
<p>Hoisting Equipment</p>	<p>Commercially manufactured lifting equipment designed to lift and position a load of known weight to a location at some known elevation and horizontal distance from the equipment's center of rotation. "Hoisting equipment" includes but is not limited to cranes, derricks, tower cranes, barge-mounted derricks or cranes, gin poles and gantry hoist systems. A "come-a-long" (a mechanical device, usually consisting of a chain or cable attached at each end, that is used to facilitate movement of materials through leverage) is not considered "hoisting equipment."</p>
<p>Hole</p>	<p>Gap or void 2 inches (5.1 cm) or more in its least dimension, in a floor, roof, or other walking/working surface.</p>
<p>Horse Scaffold</p>	<p>Supported scaffold consisting of a platform supported by construction horses</p>

<p>I</p>	<p>(saw horses).</p> <p>Hot Work Horse scaffolds constructed of metal are sometimes known as trestle scaffolds.</p> <p>Hot Work to be defined as any work that can give off a source of ignition, or that in any way can start a fire for example, cutting, welding, thermit welding, brazing, soldering, grinding, thermal spraying, thawing pipe, cadwelding, installation of torch-applied roof systems or any other similar operation or activity.</p>
<p>Identified</p> <p>Individual Rung Ladders</p> <p>Infeasible</p> <p>Insulated Conductor</p> <p>Insured</p> <p>Interior Hung Scaffold</p> <p>Interrupter Switch</p> <p>Isolated</p> <p>J</p>	<p>Suitability of equipment for a specific purpose, environment, or application is determined by a qualified testing laboratory where such identification includes labeling or listing.</p> <p>Ladders without a side rail or mid center rail support. Such ladders are made by mounting individual steps or rungs directly to the side or wall of the structure.</p> <p>Impossible to perform the construction work using a conventional fall protection system (i.e., guardrail system, safety net system, or personal fall arrest system) or that it is technologically impossible to use any one of these systems to provide fall protection.</p> <p><i>See</i> Guardrail System and Personal Fall Arrest System</p> <p><i>See</i> Conductor</p> <p>Includes the owner, et al, and the CM, GC, subcontractor or sub-subcontractors.</p> <p>Suspension scaffold consisting of a platform suspended from the ceiling or roof structure by fixed length supports.</p> <p>Over 600 volts, nominal.</p> <p>A switch capable of making, carrying, and interrupting specified currents.</p> <p>Not readily accessible to persons unless special means for access are used.</p>
<p>Job Made Ladder</p>	<p>Ladder that is fabricated by employees, typically at the construction site, and is not commercially manufactured. This definition does not apply to any individual rung/step ladders.</p>

K

Kick Out

Accidental release or failure of a cross brace.

L

Labeled

Equipment or materials to which has been attached a label, symbol or other identifying mark of a qualified testing laboratory which indicates compliance with appropriate standards or performance in a specified manner.

Ladder Jack Scaffold

Supported scaffold consisting of a platform resting on brackets attached to ladders.

Ladder Stand

Mobile fixed size self supporting ladder consisting of a wide flat tread ladder in the form of stairs. The assembly may include handrails.

Landing

Platform at the end of a flight of stairs.

Lanyard

Flexible line of rope, wire rope, or strap, suitable for supporting one person, which generally has a connector at each end for connecting the body belt or body harness to a deceleration device, lifeline, or anchorage.

Large Area Scaffold

Pole scaffold, tube and coupler scaffold, systems scaffold, or fabricated frame scaffold erected over substantially the entire work area. For example: a scaffold erected over the entire floor area of a room.

Layered System

Two or more distinctly different soil or rock types arranged in layers. Micaceous seams or weakened planes in rock or shale are considered layered.

Leading

Edge of a floor, roof, or formwork for a floor or other walking/working surface (such as the deck) which changes location as additional floor, roof, decking, or formwork sections are placed, formed, or constructed.

Lean-To Scaffold

A leading edge is considered to be an "unprotected side and edge" during periods when it is not actively and continuously under construction.

Supported scaffold that is kept erect by tilting it toward and resting it against a building or structure.

Ledger

See Runner

Lifeline

Component consisting of a flexible line for connection to an anchorage at one end to hang vertically (vertical lifeline), or for connection to anchorages at both ends to stretch horizontally (horizontal lifeline), and which serves as a means for connecting other components of a personal fall arrest system to the anchorage.

Lighting Outlet	An outlet intended for the direct connection of a lampholder, a lighting fixture, or a pendant cord terminating in a lampholder.
Limited Access Zone	An area alongside masonry wall, which is under construction and which is clearly demarcated to limit access by employees.
Line Project	Is a major project such as new schools, major modernization, additions, and athletic fields. Line project may involve many capital categories or types of work in one project and are funded through their own OMB Certificate to Proceed (CP).
Liquefied Petroleum Gases (LPG) or (LP Gas)	Includes any material which is composed predominantly of any of the following hydrocarbons, or mixtures of them, such as propane, propylene, butane (normal butane or isobutene) and butylenes.
Listed	Equipment or materials included in a list published by a qualified testing laboratory whose listing states either that the equipment or material meets appropriate standards or has been tested and found suitable for use in a specified manner.
Lower Levels	Areas or surfaces below where an employee is located and can fall from a stairway or ladder. Such areas or surfaces include, but are not limited to, ground levels, floors, roofs, platforms, ramps, runways, excavations, pits, tanks, materials, water, equipment, structures, or portions thereof.
Low-slope Roof	Roof having a slope less than or equal to 4 in 12 (vertical to horizontal).
M	
Masons' Adjustable Supported Scaffold	<i>See</i> Self-contained adjustable scaffold
Masons' Multi-Point Adjustable Suspension Scaffold	Continuous run suspension scaffold designed and used for masonry operations.
Maximum Allowable Slope	Steepest incline of an excavation face that is acceptable for the most favorable site conditions as protection against cave-ins, and is expressed as the ratio of horizontal distance to vertical rise (H:V).
Maximum Intended Load	Total load of all persons, equipment, tools, materials, transmitted loads, and other loads reasonably anticipated to be applied to a scaffold or scaffold component at any one time.
Mechanical Equipment	All motor or human propelled-wheeled equipment used for roofing work, except wheelbarrows and mop carts.
Metal Decking	Commercially manufactured, structural grade, cold rolled metal panel formed into a series of parallel ribs; for this subpart, this includes metal floor and roof decks, standing seam metal roofs, other metal roof systems and other products

	<p>such as bar gratings, checker plate, expanded metal panels, and similar products.</p> <p>After installation and proper fastening, these decking materials serve a combination of functions including, but not limited to: a structural element designed in combination with the structure to resist, distribute and transfer loads, stiffen the structure and provide a diaphragm action; a walking/working surface; a form for concrete slabs; a support for roofing systems; and a finished floor or roof.</p>
Mobile Scaffold	Powered or unpowered portable caster or wheel-mounted supported scaffold.
Moist Soil	Condition in which a soil looks and feels damp. Moist cohesive soil can easily be shaped into a ball and rolled into small diameter threads before crumbling. Moist granular soil that contains some cohesive material will exhibit signs of cohesion between particles.
MSDS	Material Safety Data Sheet
Multi-Level Suspended Scaffold	Suspension scaffold with a series of platforms at various levels resting on common stirrups.
Multiple Lift Rigging	Rigging assembly manufactured by wire rope rigging suppliers that facilitates the attachment of up to five independent loads to the hoist rigging of a crane.
Multi-Point Adjustable Suspension Scaffold	Suspension scaffold consisting of a platform(s) which is suspended by more than two ropes from overhead supports and equipped with means to raise and lower the platform to desired work levels. Such scaffolds include chimney hoists.
N	
Needle Beam Scaffold	Platform suspended from needle beams.
Nosing	Portion of a tread projecting beyond the face of the riser immediately below.
O	
Occupied School Building/Premise	Any building occupied with minors at anytime including but not limited to; before and after school hours, weekends, and holidays.
Open Side and Ends	<p>Edges of a platform that are more than 14 inches (36 cm) away horizontally from a sturdy, continuous, vertical surface (such as a building wall) or a sturdy, continuous horizontal surface (such as a floor), or a point of access.</p> <p> Exception: For plastering and lathing operations the horizontal threshold distance is 18 inches (48 cm).</p>

P	Opening	<p>A gap or void 30 inches (76 cm) or more high and 18 inches (48 cm) or more wide, in a wall or partition, through which employees can fall to a lower level.</p> <p>A gap or void 12 inches (30.5 cm) or more in its least dimension in a floor, roof or other walking/working surface.</p> <p>Skylights and smoke domes that do not meet the strength requirements of § 1926.754(e)(3) shall be regarded as openings.</p>
	Optical Density (OD)	The light refractive characteristics of a lens.
	Outrigger	Structural member of a supported scaffold used to increase the base width of a scaffold in order to provide support for and increased stability of the scaffold.
	Outrigger Beam	Structural member of a suspension scaffold or outrigger scaffold which provides support for the scaffold by extending the scaffold point of attachment to a point out and away from the structure or building.
	Outrigger Scaffold	Supported scaffold consisting of a platform resting on outrigger beams projecting beyond the wall or face of the building or structure, the inboard ends of which are secured inside the building or structure.
	Overhand Bricklaying and Related Work	<p>Process of laying bricks and masonry units such that the surface of the wall to be jointed is on the opposite side of the wall from the mason, requiring the mason to lean over the wall to complete the work.</p> <p>Related work includes mason tending and electrical installation incorporated into the brick wall during the overhand bricklaying process.</p>
	Owner	Department of Education (DOE)
	Owners Representative	The New York City School Construction Authority (NYCSCA)
	Panelboard	<p>A single panel or group of panel units designed for assembly in the form of a single panel; including buses, automatic over current devices, and with or without switches for the control of light, heat, or power circuits; designed to be placed in a cabinet or cutout box placed in or against a wall or partition and accessible only from the front.</p> <p><i>See Switchboard</i></p>
	Permanent Floor	Structurally completed floor at any level or elevation (including slab on grade).
Permit Required Confined Space	<p>A confined space that has one or more of the following characteristics:</p> <ul style="list-style-type: none"> Contains or has the potential to contain a hazardous atmosphere Contains a material that has the potential for engulfing an entrant Has an internal configuration such that an entrant could be trapped or asphyxiated by inwardly converging walls or by a floor which slopes 	

	<p>downward and tapers to a smaller cross-section</p> <p>Contains any other recognized serious safety or health hazard</p>
Personal Fall Arrest System	<p>System used to arrest an employee's fall from a working level. It consists of an anchorage, connectors, or body harness and may include a lanyard, deceleration device, lifeline, or suitable combinations of these.</p> <p> Attention: As of January 1, 1998, the use of a body belt for fall arrest is prohibited.</p>
Photo I.D.	<p>Information badge worn while on any occupied SCA project. The photo I.D. is to contain; a clear, current photo, the name of the person in the photo, the title of the company the person is working for along with the address and phone number of the company.</p>
Plastic	<p>Property of a soil, which allows the soil to be deformed or molded without cracking, or appreciable volume change.</p>
Platform	<p>Work surface elevated above lower levels. Platforms can be constructed using individual wood planks, fabricated planks, fabricated decks, and fabricated platforms.</p>
Plug Cap	<p><i>See Attachment Plug</i></p>
Point of Access	<p>Areas used by employees for work related passage from one area or level to another. Such open areas include doorways, 1 passageway, stairway openings, studded walls, and various other permanent or temporary openings used for such travel.</p>
Portable Ladder	<p>Ladder that can be readily moved or carried.</p>
Portable Tank	<p>Closed container having a liquid capacity more than 60 US gallons and not intended for fixed installation.</p>
Positioning Device	<p>Body belt or body harness rigged to allow an employee to be supported on an elevated, vertical surface, such as a wall or column and work with both hands free while leaning.</p>
Positioning Device System	<p>Body belt or body harness system rigged to allow an employee to be supported on an elevated vertical surface, such as a wall, and work with both hands free while leaning.</p>
Post	<p><i>See Body Belt and Body Harness</i></p> <p>Structural member with a longitudinal axis that is essentially vertical, that: (1) weighs 300 pounds or less and is axially loaded (a load presses down on the top end), or (2) is not axially loaded, but is laterally restrained by the above member. Posts typically support stair landings, wall framing, mezzanines and other substructures.</p>
Power Outlet	<p>An enclosed assembly which may include receptacles, circuit breakers, fuseholders, fused switches, buses and watt-hour meter mounting means; intended to serve as a means for distributing power required to operate mobile or temporarily installed equipment.</p>

Pre-cast Concrete	Concrete members (such as walls, panels, slabs, columns, and beams) which have been formed, cast, and cured prior to final placement in a structure.
Premises Wiring System	That interior and exterior wiring, including power, lighting, control, and signal circuit wiring together with all of its associated hardware, fittings, and wiring devices, both permanently and temporarily installed, which extends from the load end of the service drop, or load end of the service lateral conductors to the outlet(s). Such wiring does not include wiring internal to appliances, fixtures, motors, controllers, motor control centers, and similar equipment.
Project Structural Engineer of Record	Registered licensed professional responsible for the design of structural steel framing and whose seal appears on the structural contract documents.
Protective System	Method of protecting employees from cave-ins, from material that could fall or roll from an excavation face or into an excavation, or from the collapse of adjacent structures. Protective systems include support systems, sloping and benching systems, shield systems, and other systems that provide the necessary protection.
Public	Any individual that is not part of the construction personnel.
Purlin	In systems-engineered metal buildings, a "Z" or "C" shaped member formed from sheet steel spanning between primary framing and supporting roof material.
Putlog	<i>See</i> Bearer
<hr/> Q <hr/>	
Qualified	One who, by possession of a recognized degree, certificate, or professional standing, or who by extensive knowledge, training, and experience, has successfully demonstrated his ability to solve or resolve problems relating to the subject matter, the work, or the project.
Qualified Person	One familiar with the construction and operation of the equipment and the hazards involved. <i>See</i> Qualified
Qualified Testing Laboratory	A properly equipped and staffed testing laboratory which has capabilities for and which provides the following services: Experimental testing for safety of specified items of equipment and materials referred to in this standard to determine compliance with appropriate test standards or performance in a specified manner; Inspecting the run of such items of equipment and materials at factories for product evaluation to assure compliance with the test standards; Service-value determinations through field inspections to monitor the proper use of labels on products and with authority for recall of the label in the event a hazardous product is installed; Employing a controlled procedure for identifying the listed and/or labeled

R

	equipment or materials tested; and Rendering creditable reports or findings that are objective and without bias of the tests and test methods employed.
Radiant Energy	Energy that travels outward in all directions from its sources.
Ramp	Inclined walking or working surface that is used to gain access to one point from another, and is constructed from earth or from structural materials such as steel or wood.
Rated Load	Manufacturer's specified maximum load to be lifted by a hoist or to be applied to a scaffold or scaffold component.
Readily Accessible	Capable of being reached quickly for operation, renewals or inspections, without requiring those to whom ready access is requisite to climb over or remove obstacles or to resort to portable ladders, chairs, etc.
Receptacle	A contact device installed at the outlet for the connection of a single attachment plug. A single receptacle is a single contact device with no other contact device on the same yoke. A multiple receptacle is a single device containing two or more receptacles.
Receptacle Outlet	Where one or more receptacles are installed in an outlet
Registered Professional Engineer	Person who is registered as a professional engineer in the state where the work is to be performed. However, a professional engineer, registered in any state is deemed to be a "registered professional engineer" within the meaning of this standard when approving designs for "manufactured protective systems" or "tabulated data" to be used in interstate commerce.
Repair Bracket Scaffold	Supported scaffold consisting of a platform supported by brackets which are secured in place around the circumference or perimeter of a chimney, stack, tank, or other supporting structure by one or more wire ropes placed around the supporting structure.
Re-shoring	The construction operation in which shoring equipment (also called re-shores or re-re-shoring equipment) is placed, as the original forms and shores are removed, in order to support partially cured concrete and construction loads.
Ribbon	<i>See Shore</i> <i>See Runner</i>
Rigging Foreman	An individual, male or female, designated by a licensed master or special rigger in accordance with subdivision I of Chapter 9 -01 of NYC Building Code Rigging Rule. Such person shall have the qualifications set forth in subdivision h of Chapter 9 -01 of NYC Building Code Rigging Rule.

Riser Height	Vertical distance from the top of a tread to the top of the next higher tread or platform/landing or the distance from the top of a platform/landing to the top of the next higher tread or platform/landing.
Roof	Exterior surface on the top of a building. This does not include floors or formwork to a building, which is temporarily the top surface, of uncompleted buildings.
Roof Bracket Scaffold	Rooftop supported scaffold consisting of a platform resting on angular-shaped supports.
Roofing Work	Hoisting, storage, application, and removal of roofing materials and equipment, including related insulation, sheet metal, and vapor barrier work, but not including the construction of the roof deck.
Rope Grab	Deceleration device that travels on a lifeline and automatically, by friction, engages the lifeline and locks to arrest the fall of an employee. A rope grab usually employs the principle of inertial locking, cam/level locking, or both.
Run Scaffold	<i>See</i> Continuous Run Scaffold
Runner	Lengthwise horizontal spacing or bracing member that may support the bearers.
S	
Safety Belt	<i>See</i> Body Belt
Safety Can	Closed container of not more than 5 gallon capacity having a flash arrestor screen, spring-closing lid and spout cover and so designed that it will safely relieve internal pressure when subjected to fire exposure.
Safety Deck Attachment	Initial attachment that is used to secure an initially placed sheet of decking to keep proper alignment and bearing with structural support members.
Safety-Monitoring System	Safety system in which a competent person is responsible for recognizing and warning employees of fall hazards.
Saturated Soil	Soil in which the voids are filled with water. Saturation does not require flow. Saturation, or near saturation, is necessary for the proper use of instruments such as a pocket penetrometer or shear vane.
SCA Insurance Administrator	An employee of the owner responsible for getting certificates of insurance claims servicing, and auditing controls.
Scaffold	Any temporary elevated platform (supported or suspended) and the supporting structure (including points of anchorage), used for supporting employees or materials or both.
Scaffold	<i>See</i> Stair Tower

Stairway/Tower	
Self-Contained Adjustable Scaffold	Combination of a supported and suspension scaffold consisting of an adjustable platform(s) mounted on an independent supporting frame(s) not a part of the object being worked on, and which is equipped with a means to permit the raising and lowering of the platform(s). Such systems include rolling roof rigs, rolling outrigger systems, and some masons' adjustable supported scaffolds.
Self-Retracting Lanyard	<i>See</i> Self-Retracting Lifeline
Self-Retracting Lifeline	Deceleration device containing a drum-wound line which can be slowly extracted from, or retracted onto, the drum under slight tension during normal employee movement, and which, after onset of a fall, automatically locks the drum and arrests the fall.
Servicing Insurance Broker	Willis Corroon, who issues Certificate of Insurance to contractors prior to working on projects.
Shear Connector	Headed steel studs, steel bars, steel lugs, and similar devices which are attached to a structural member for the purpose of achieving composite action with concrete.
Sheeting	Members of a shoring system that retain the earth in position and in turn are supported by other members of the shoring system.
Shield	Structure that is able to withstand the forces imposed on it by a cave-in and thereby protect employees within the structure. Shields can be permanent structures or can be designed to be portable and moved along as work progresses. Additionally, shields can be either pre-manufactured or job-built in accordance with this section. Shields used in trenches are usually referred to as "trench boxes" or "trench shields."
Ship Scaffold	<i>See</i> Float Scaffold
Shore	A supporting member that resists a compressive force imposed by a load.
Shore Scaffold	Supported scaffold that is placed against a building or structure and held in place with props.
Shoring	Structure such as a metal hydraulic, mechanical or timber shoring system that supports the sides of an excavation and which is designed to prevent cave-ins.
Short Term Exposure	Period of time less than or equal to 24 hours that an excavation is open.
Sides	<i>See</i> Faces or Sides
Sign Hanging Foreman	An individual, male or female, designated by a licensed master or special sign hanger in accordance with subdivision h of Section 9-02 NYCBC Rigging Rule. Such person shall have the qualifications set forth in subdivision g of Section 9-02 NYCBC Rigging Rule.
Signals	Moving signs provided by workers, such as flagmen, or by devices, such as flashing lights, to warn of possible or existing hazards.

Signs	Warnings of hazard, temporarily or permanently affixed or placed, at locations where hazards exist.
Single Cleat Ladder	Ladder consisting of a pair of side rails, connected together by cleats, rungs, or steps.
Single Rail Ladder	Portable ladder with rungs, cleats, or steps mounted on single rail instead of the normal two rails used on most other ladders.
Single-Point Scaffold	Supported scaffold consisting of a platform suspended by one rope from overhead support and equipped with means to permit the movement of the platform to desired work levels.
Sloping	Method of protecting employees from cave-ins by excavating to form sides of an excavation that is inclined away from the excavation so as to prevent cave-ins. The angle of incline required to prevent a cave-in varies with differences in such factors as the soil type, environmental conditions of exposure, and application of surcharge loads.
Snaphook	<p>Connector comprised of a hook-shaped member with a normally closed keeper, or similar arrangement, which may be opened to permit the hook to receive an object and, when released, automatically closes to retain the object. Snaphooks are generally one of two types:</p> <p>The locking type with a self-closing, self-locking keeper which remains closed and locked until unlocked and pressed open for connection or disconnection</p> <p>The non-locking type with a self-closing keeper which remains closed until pressed open for connection or disconnection. As of January 1, 1998, the use of a non-locking snaphook as part of personal fall arrest systems and positioning device systems is prohibited</p>
Soil Classification System	<p>Method of categorizing soil and rock deposits in a hierarchy of Stable Rock, Type A, Type B, and Type C, in decreasing order of stability. The categories are determined based on an analysis of the properties and performance characteristics of the deposits and the characteristics of the deposits and the environmental conditions of exposure.</p> <p>Type A</p> <p>Cohesive soils with an unconfined, compressive strength of 1.5 ton per square foot (tsf) (144 kPa) or greater. Examples of cohesive soils are: clay, silty clay, sandy clay, clay loam and, in some cases, silty clay loam and sandy clay loam. Cemented soils such as caliche and hardpan are also considered Type A.</p> <p>However, no soil is Type A if:</p> <ul style="list-style-type: none"> The soil is fissured; or The soil is subject to vibration from heavy traffic, pile driving, or similar effects; or The soil has been previously disturbed; or The soil is part of a sloped, layered system where the layers dip into the excavation on a slope of four horizontal to one vertical (4H:1V) or greater; or The material is subject to other factors that would require it to be classified as a less stable material.

	<p>Type B</p> <p>Cohesive soil with an unconfined compressive strength greater than 0.5 tsf (48 kPa) but less than 1.5 tsf (144 kPa)</p> <p>Granular cohesionless soils including: angular gravel (similar to crushed rock), silt, silt loam, sandy loam and, in some cases, silty clayloam and sandy clay loam.</p> <p>Previously disturbed soils except those, which would otherwise be classed as Type C soil.</p> <p>Soil that meets the unconfined compressive strength or cementation requirements for Type A, but is fissured or subject to vibration</p> <p>Dry rock that is not stable</p> <p>Material that is part of a sloped, layered system where the layers dip into the excavation on a slope less steep than four horizontal to one vertical (4H:1V), but only if the material would otherwise be classified as Type B.</p> <p>Type C</p> <p>Cohesive soil with unconfined compressive strength of 0.5 tsf (48 kPa) or less</p> <p>Granular soils including gravel, sand, and loamy sand</p> <p>Submerged soil or soil from which water is freely seeping</p> <p>Submerged rock that is not stable</p> <p>Material in a sloped, layered system where the layers dip into the excavation on a slope of four horizontal to one vertical (4H:1V) or steeper.</p>
Spiral Stairway	Series of steps attached to a vertical pole and progressing upward in a winding fashion within a cylindrical space.
Stable Rock	Natural solid mineral material that can be excavated with vertical sides and will remain intact while exposed.
Stair Rail System	Unstable rock is considered to be stable when the rock material on the side or sides of the excavation is secured against caving-in or movement by rock bolts or by another protective system that has been designed by a registered professional engineer. Vertical barrier erected along the unprotected sides and edges of a stairway to prevent employees from falling to lower levels. The top surface of a stair rail system may also be a "handrail."
Stair Tower	Tower comprised of scaffold components and which contains internal stairway units and rest platforms. These towers are used to provide access to scaffold platforms and other elevated points such as floors and roofs.
Stall Load	Load at which the prime-mover of a power-operated hoist stalls or the power to the prime-mover is automatically disconnected.
Steel Erection	Construction, alteration or repair of steel buildings, bridges and other structures, including the installation of metal decking and all planking used during the process of erection.

Steel Joist	Open web, secondary load-carrying member of 144 feet (43.9 m) or less, designed by the manufacturer, used for the support of floors and roofs. This does not include structural steel trusses or cold-formed joists.
Steel Joist Girder	Open web, primary load-carrying member, designed by the manufacturer, used for the support of floors and roofs. This does not include structural steel trusses.
Steel Truss	Open web member designed of structural steel components by the project structural engineer of record. For the purposes of this subpart, a steel truss is considered equivalent to a solid web structural member.
Steep Roof	Roof having a slope greater than 4 in 12 (vertical to horizontal).
Step Stool	Self supporting, foldable, portable ladder, nonadjustable in length, 32 inches or less in overall size, with flat steps and without a pail shelf, designed to be climbed on the ladder top cap as well as all steps. The side rails may continue above the top cap.
Step, Platform, and Trestle Ladder Scaffold	Platform resting directly on the rungs of step ladders or trestle ladders.
Stonesetters' Multi-Point Adjustable Suspension Scaffold	A continuous run suspension scaffold designed and used for stonemasons' operations.
Structural Ramp	Ramp built of steel or wood, usually used for vehicle access. Ramps made of soil or rocks are not considered structural ramps.
Structural Steel	Steel member, or a member made of a substitute material (such as, but not limited to, fiberglass, aluminum or composite members). These members include, but are not limited to, steel joists, joist girders, purlins, columns, beams, trusses, splices, seats, metal decking, girts, and all bridging, and cold formed metal framing which is integrated with the structural steel framing of a building.
Subcontractor, and Sub-Subcontractor(s)	A contractor. <i>See Contractor</i>
Submerged Soil	Soil which is underwater or is free seeping.
Support System	Structure such as underpinning, bracing, or shoring, which provides support to an adjacent structure, underground installation, or the sides of an excavation.
Supported Scaffold	One or more platforms supported by outrigger beams, brackets, poles, legs, uprights, posts, frames, or similar rigid support.
Suspension Scaffold	One or more platforms suspended by ropes or other non-rigid means from an overhead structure(s).
Swing Stage	<i>See Two-point suspension scaffold</i>
Switchboard	A large single panel, frame, or assembly of panels which have switches, buses,

	instruments, over current and other protective devices mounted on the face or back or both. Switchboards are generally accessible from the rear as well as from the front and are not intended to be installed in cabinets.
	<i>See</i> Panelboard
System Scaffold	Scaffold consisting of posts with fixed connection points that accept runners, bearers, and diagonals that can be interconnected at predetermined levels.
Systems-Engineered Metal Building	Metal, field-assembled building system consisting of framing, roof and wall coverings. Typically, many of these components are cold-formed shapes. These individual parts are fabricated in one or more manufacturing facilities and shipped to the job site for assembly into the final structure. The engineering design of the system is normally the responsibility of the systems-engineered metal building manufacturer.
T	
Tabulated Data	Tables and charts approved by a registered professional engineer and used to design and construct a protective system.
Tags	Temporary signs, usually attached to a piece of equipment or part of a structure, to warn of existing or immediate hazards.
Tank	Container for holding gases, liquids or solids.
Tank Builders' Scaffold	Supported scaffold consisting of a platform resting on brackets that are either directly attached to a cylindrical tank or attached to devices that are attached to such a tank.
Thrustout	<i>See</i> Outrigger Beam
Toeboard	A low protective barrier that will prevent the fall of materials and equipment to lower levels and provide protection from falls for personnel.
Top Plate Bracket Scaffold	Scaffold supported by brackets that hook over or are attached to the top of a wall. This type of scaffold is similar to carpenters' bracket scaffolds and form scaffolds and is used in residential construction for setting tresses.
Tread Depth	Horizontal distance from front to back of a tread (excluding nosing, if any).
Trench	Narrow excavation (in relation to its length) made below the surface of the ground. In general, the depth is greater than the width, but the width of a trench (measured at the bottom) is not greater than 15 feet (4.6 m). If forms or other structures are installed or constructed in an excavation so as to reduce the dimension measured from the forms or structure to the side of the excavation to 15 feet (4.6 m) or less (measured at the bottom of the excavation), the excavation is also considered to be a trench.
Trench Box	<i>See</i> Shield
Trench Shield	<i>See</i> Shield

Tube and Coupler Scaffold	Supported or suspended scaffold consisting of platform(s) supported by tubing, erected with coupling devices connecting uprights, braces, bearers, and runners.
Tubular Welded Frame Scaffold	<i>See</i> Fabricated frame scaffold
Two-Point Suspension Scaffold	Suspension scaffold consisting of a platform supported by hangers (stirrups) suspended by two ropes from overhead supports and equipped with means to permit the raising and lowering of the platform to desired work levels.
U	
Unconfined Compressive Strength	Load per unit area at which a soil will fail in compression. It can be determined by laboratory testing, or estimated in the field using a pocket penetrometer, by thumb penetration tests, and other methods.
Unprotected Sides and Edges	Any side or edge (except at entrances to points of access) of a walking, working, or stairway where there is no stair rail system or wall 36 inches or more in height.
	Any side or edge (except at entrances to points of access) of a stairway landing, or ladder platform where there is no wall or guardrail system 39 inches or more in height.
Unstable Objects	 Example: Floor, roof, ramp, or runway where there is no wall or guardrail system at least 39 inches (1.0 m) high.
	Items whose strength, configuration, or lack of stability may allow them to become dislocated and shift and therefore may not properly support the loads imposed on them. Unstable objects do not constitute a safe base support for scaffolds, platforms, or employees. Examples include, but are not limited to barrels, boxes, loose brick, pallets, and concrete blocks.
Uprights	Vertical members of a trench shoring system placed in contact with the earth and usually positioned so that individual members do not contact each other. Uprights placed so that individual members are closely spaced, in contact with or interconnected to each other, are often called "sheeting."
V	
Vapor Pressure	Pressure measured in pounds per square inch (absolute) exerted by a volatile liquid as determined by the Standard Method of test for Vapor Pressure of Petroleum Products (Reid Method), ASTM D-328-58.
Vertical Pickup	Rope used to support the horizontal rope in catenary scaffolds.

Vertical Slip Forms	Forms jacked vertically during the placement of concrete.
W	
Wales	Horizontal members of a shoring system placed parallel to the excavation face whose sides bear against the vertical members of the shoring system or earth.
Walking Surface	Any surface, whether horizontal or vertical on which an employee walks or works, including, but not limited to, floors, roofs, ramps, bridges, runways, formwork and concrete reinforcing steel but not including ladders, vehicles, or trailers, on which employees must be located in order to perform their job duties.
Walkway	Portion of scaffold platform used only for access and not as a work level.
Weatherproof	So constructed or protected that exposure to the weather will not interfere with successful operation. Rainproof, rain tight, or watertight equipment can fulfill the requirements for weatherproof where varying weather conditions other than wetness, such as snow, ice, dust, or temperature extremes, are not a factor.
Wet Soil	Soil that contains significantly more moisture than moist soil, but in such a range of values that cohesive material will slump or begin to flow when vibrated. Granular material that would exhibit cohesive properties when moist will lose those cohesive properties when wet.
Window Jack Scaffold	Platform resting on a bracket or jack that projects through a window opening.
Work Area	Portion of a walking/working surface where job duties are being performed.
Working Surface	<i>See</i> Walking Surface

Web Resources

NYC SCA

<http://www.nycsca.org>

<http://schools.nyc.gov/Offices/SCA/AboutUs/default.htm>

FDNY

<http://www.nyc.gov/fdny>

NYC DOB Construction Safety Website

http://nyc.gov/html/dob/html/construction_safety/construction_safety.shtml

NYC DOB Local Law 52 Supported Scaffold

http://.nyc.gov/html/dob/downloads/pdf/ll_52of2005.pdf

NYC DOB Excavation/Earthwork Regulation — Rule 52 Fact sheet:

http://nyc.gov/html/dob/downloads/pdf/rule_52_factsheet.pdf

NYC DOB Suspended Scaffold Tips

http://www.nyc.gov/html/dob/html/applications_and_permits/suspended_scaffold_safety.shtml

NYC DOB construction Sign Requirements:

http://www.nyc.gov/html/dob/html/applications_and_permits/311_const_signs_req_update.shtml

OSHA U.S. Department of Labor, Occupational Safety & Health Administration

<http://osha.gov/>

NYC Department of Environmental Protection Website: Noise Code (Local Law 113 of 2005)

http://www.nyc.gov/html/dep/html/air_and_noise/index.shtml

FEMA Emergency Management Online Training Site:

<http://training.fema.gov/is/>

NYS Department of Labor Industrial Code 23, Protection In Construction, Demolition, and Excavation Operations

<http://www.labor.state.ny.us/workerprotection/safetyhealth/sh23.shtm>