



**SERIES TS 870 • 100 - 1200 AMP
AUTOMATIC TRANSFER SWITCH**
COMMERCIAL, INDUSTRIAL



TS 870 AUTOMATIC TRANSFER SWITCHES OFFER:

ENCLOSED CONTACT POWER SWITCHING UNITS

- Fully enclosed silver alloy contacts provide high withstand rating & 100% continuous current rating
- 3 cycle short circuit current withstand
- 10 cycle 6X overload current rating
- Completely isolated utility and generator side power switching units
- Power switching units can incorporate over current protection, allowing cost savings in upstream devices
- Switching manually will prevent damage while in service

RELIABLE MOTOR-OPERATED TRANSFER MECHANISM

- Heavy duty brushless gearmotor and operating mechanism provide mechanical interlocking (for open transition ATS) and longer product life
- Stored Energy: Motor Operators for fast CTTS
- Safe manual operation permits operation under adverse conditions

SUPERIOR SERVICEABILITY

- All mechanical and control devices are visible and front accessible
- All control wires and power busses are front accessible
- Plug-in TSC 7320 Transfer Switch Controller

CONTROL FEATURES

- TSC 7320 Advanced ATS Controller with 2.3" back-lit LCD display and programmable inputs/outputs
- Isolation plug permits disconnecting control circuits from all power sources

PRODUCT DATA

- Models from 100 - 1200A continuous current
- Available 2, 3 or 4 pole
- All models 50/60Hz rated
- Voltage range 120 - 600VAC
- 3 phase, 3 or 4 wire systems
- Open Transition or Closed Transition ATS
- 1000 - 1200A offer fast Open Transition transfer, with phase monitoring

SEISMIC CERTIFICATION:

TS 870 ATS is certified for installation and operation per the following requirements:

- IBC 2012 – Section 13, Occupancy Category IV
- ASCE7 - 05 Region 3 (minimum SS=200%)

SAFETY STANDARDS

- UL™* 1008 Automatic Transfer Switches for use in Emergency Systems
- CSA™* C22.2 No. 178 Automatic Transfer Switches
- NFPA™* 110 Standard for Emergency and Standby Power Systems

WARRANTY

- 2 year limited warranty included

TS 870 Automatic Transfer Switches employ two mechanically interlocked power switching units with an Advanced ATS Controller to automatically start a generator and transfer system load to a generator supply in the event of a utility supply failure. System load is then automatically re-transferred back to the utility supply following restoration of the utility power source to within normal operating limits. All load transfer sequences are "Open Transition" (i.e., break-before-make) with adjustable neutral position delay to ensure adequate voltage delay for preventing out of phase transfers .

TS 870 Automatic Transfer Switches are certified to UL 1008 & CSA 178 Standards for use in Emergency Power Systems applications.

All TS 870 Transfer Switch models have been 3 cycle withstand current tested in accordance with UL 1008 & CSA 178. Additionally, they can withstand 6 times overload for 10 cycles. The standard TS 870 Automatic Transfer Switch is rated for 100% system load. The TS 870 design allows for optional use of integral over current trip elements within the power switching units. All TS 870 Automatic Transfer Switches use a TSC 7320 Advanced ATS Controller which provides all necessary control functions for fully automatic operation. The controller is equipped with 2.3" back-lit LCD display which provides operating status and controls. All parameters and configurations are entered without opening the front door.

* See last page for attribution.

CLOSED TRANSITIONS ATS (MOMENTARY)

TS 870 Closed Transition Transfer Switch (1000A - 1200A CTTS) employs two stored energy, motor operated electrically interlocked molded case (MCCB/MCS) power switching units and an Advanced ATS Controller to automatically allow a Closed Transition ("make-before-break") load transfer when both utility and generator sources are available. All Closed Transition transfer sequences ensure both sources of power are in synchronism prior to transfer and load is transferred without power interruption. Automatic control & protection circuits ensure the generator and utility supplies are only in parallel for a maximum of 100 ms to permit an uninterrupted load transfer.

In the event of a utility supply failure, the TS 870 CTTS will automatically revert to an Open Transition load transfer sequence to transfer system load automatically to the generator supply. System load is then automatically re-transferred back to the utility supply utilizing a Closed Transition transfer sequence following restoration of the utility power source to within normal operating limits. All Closed Transition transfer sequences will be inhibited when only one source of power is available. The Closed Transition feature is a standard option that can be applied to the TS 870 model.

TS 870 CTTS are specifically designed and certified to UL™* 1008 Standards, for use in Emergency Power Systems applications such as commercial, industrial, or government institutions that require automatic standby power and minimal power interruptions to the load.

The TS 870 CTTS use the TSC 7320 controller, with built-in Sync Check relay, which contains adjustable voltage differential/slip frequency threshold limits. The paralleling time is less than 100ms. A timer monitors the Closed Transition period, and will isolate, should the closed-transition time exceed the setting of the timer. If the device fails to open within 100ms, an additional Extended Paralleling Protection is provided to ensure isolation by opening the other source within 500ms.

Closed Transition Mode can be bypassed to Open Transition Mode within the TSC 7320 Controller. An Auto/Manual Switch is provided for safe manual operation in Open Transition mode with positive pushbutton controls.

Note: 400 - 800A CTTS are implemented using the TSC 900 controller



CONTROLLER SYNC SCREEN EXAMPLES

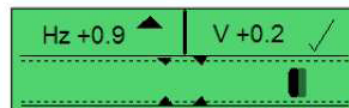

Figure 1

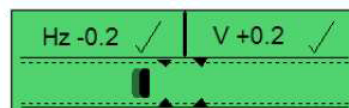

Figure 2

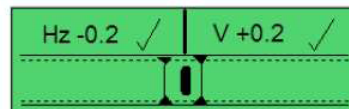

Figure 3

* See last page for attribution.

BYPASS ISOLATION ATS

Note: TS870 400A to 800A 4 Breaker bypass configuration ATS is implemented using the TS870 with TSC900 controller. Refer to the TS870 Commercial & Industrial ATS datasheet CL062 for details.

TS 870 Bypass/Isolation Automatic Transfer Switches employ an interlock power switching mechanism that provides an easy and safe procedure for system maintenance personnel to manually isolate and bypass an Automatic Transfer Switch. The Bypass/Isolation switch is manually operated, and allows either generator or utility source to be bypassed to maintain power to the load while the Automatic Transfer Switch is tested for maintenance procedures as required. The Bypass/Isolation procedure allows a fast, simple, and reliable method of isolating and bypassing the Automatic Transfer Switch through a "make-before-break" bypass design. The interlocking mechanism ensures that the utility and generator sources cannot be paralleled under any circumstance and the transfer switch may be bypassed to either source.

The TS 870 Bypass/Isolation Automatic Transfer Switch is supplied as a single complete assembly with all power conductors provided between the bypass mechanism and the transfer switch. Provisions for all external power cabling for the utility, generator and load conductors are provided for in the bypass/isolation compartment of the switch. The Bypass/Isolation Switch and Transfer Switch are mounted in separate barriered compartments.

For transfer switches rated 1000A - 1200A using molded case power switching devices, the bypass/isolation mechanism consists of two electrically interlocked power switch devices and draw-out transfer power switching devices. Utilizing independent switching units provides a high degree of reliability and redundancy not available in other switches.

TS 870 Bypass/Isolation Automatic Transfer Switches are specifically designed and certified to UL™* 1008 and CSA™*22.2 No. 178 Safety Standards

All TS 870 Bypass/Isolation Automatic Transfer Switch models have been 3 cycle withstand current tested in accordance with UL 1008 and CSA 22.2 No.178.

The standard TS 870 Bypass/Isolation Automatic Transfer Switch is rated 100% system load and requires upstream over current protection

Note: Automatic Transfer Switch units rated 1000A - 1200A utilizing insulated case power switching units with a closed transition option may be operated in a "make-before-break" sequence at the operators' direction.



1000A/ 1200A TS870 Bypass,
4 breaker configuration

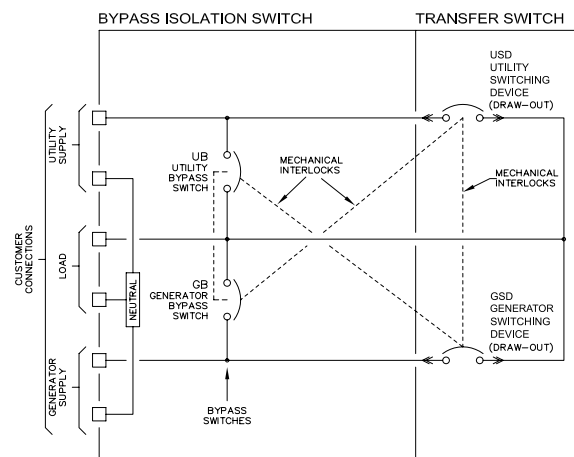

1000A - 1200A Molded Case
Bypass/Isolation Automatic Transfer Switch

TYPICAL SINGLE LINE DIAGRAM

* See last page for attribution.

SERVICE ENTRANCE ATS (For U.S. Market Only)

TS 870 Service Entrance (SE) Automatic Transfer Switches incorporate an isolating mechanism and over current protection on the utility supply, thereby removing the need to have a separate, upstream circuit breaker/ disconnect switch. This unique Service Entrance Rated Automatic Transfer Switch design is incorporated into a standard sized Automatic Transfer Switch enclosure.

Standard features of the Service Entrance Rated Automatic Transfer Switch include a NEMA®* 1 rated enclosure, pad-lockable Service Disconnect control switch and status indications.

TS 870 SE Service Disconnect operation ensures a high level of safety for system maintenance personnel. Normal operation and performance of the Automatic Transfer Switch is unaffected by the Service Entrance ATS feature. The TS 870 SE Automatic Transfer Switch is rated for the system load and requires upstream over current protection on the generator supply.

TS 870 SE Automatic Transfer Switches use a type TSC 7320 microprocessor based controller.

TYPICAL SINGLE LINE DIAGRAM

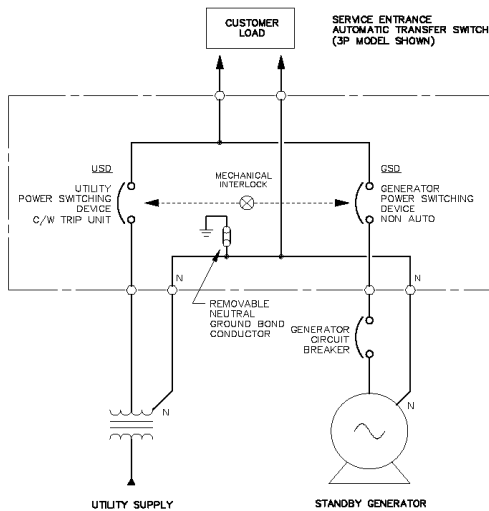

* See last page for attribution.

WITHSTAND CURRENT RATINGS (3 CYCLE MODELS)

MODEL	Type	MAX VOLTAGE	WITHSTAND CURRENT RATING AMPS (RMS) ¹		
			@240V	@480V	@600V
TS 87xA-0100	100A	600	65,000	25,000	18,000
TS 87xA-0150	150A	600	65,000	25,000	18,000
TS 87xA-0200	200A	240	65,000	N/A	N/A
TS 87xA-0250	250A ²	600	65,000	65,000	35,000
TS 87xA-0400	400A	600	65,000	50,000	35,000
TS 87xA-0600	600A	600	65,000	50,000	35,000
TS 87xA-0800	800A	600	65,000	50,000	35,000
TS 87xA-1000	1000A	600	150,000	100,000	65,000
TS 87xA-1200	1200A	600	150,000	100,000	65,000

¹ Note: For power switching devices equipped with optional over current trip units, standard interrupting ratings are identical to withstand ratings shown at 240V and 480V. For interrupting ratings at 600V, contact Thomson Technology Power Systems.

² Note: Withstand rating specified is for 250A, 3P. For 250A, 4P, the withstand ratings are 65KA@240V, 35KA@480V and 22KA@600V.

ENCLOSURE DIMENSIONS/CABLE TERMINALS (ATS ONLY) (NEMA®* 1, ASA #61 GRAY)

AMPERAGE	# OF POLES	DIMENSIONS ¹			SHIPPING WEIGHT lbs (kg)	TERMINAL RATING ²	
		HEIGHT INCHES (mm)	WIDTH INCHES (mm)	DEPTH ³ INCHES (mm)		QTY (PER PHASE)	RANGE
100A	2, 3, 4	31.1 (790)	22.3" (566)	14" (356)	143 lbs (65)	1	#14 - 1/0
150A	2, 3, 4	31.1" (790)	22.3" (566)	14" (356)	143 lbs (65)	1	#2 - 4/0
200A	2, 3, 4	31.1" (790)	22.3" (566)	14" (356)	143 lbs (65)	1	#6 - 350 mcm
250A	2, 3, 4	35.1" (892)	27.3" (693)	14" (356)	172 lbs (78)	1	#6 - 350 mcm
400A	2, 3	43.1" (1095)	34.3" (873)	13" (330)	227 lbs (103)	2	2/0 - 500 mcm
400A	4	48.1" (1222)	37.8" (960)	14.5" (368)	256 lbs (116)	2	2/0 - 500 mcm
600A	2, 3	46.1" (1171)	36.3" (922)	14.5" (368)	248 lbs (113)	2	2/0 - 500 mcm
600A	4	48.1" (1222)	37.8" (960)	14.5" (368)	256 lbs (116)	2	2/0 - 500 mcm
800A	2, 3	48.1" (1222)	37.8" (960)	14.5" (368)	309 lbs (140)	3	2/0 - 500 mcm
800A	4	63.1" (1603)	40.8" (1036)	14.5" (368)	367 lbs (167)	3	2/0 - 500 mcm
400A - 800A CTTS	2, 3, 4	64" (1626)	30" (762)	13" (330)	400 lbs (181)	3	2/0 - 500 mcm
1000A/1200A (ALL)	2, 3, 4	70" (1780)	34.3" (871)	14" (356)	550 lbs (249)	4	4/0 - 500 mcm

¹ Enclosure dimensions are for reference. (NOT FOR CONSTRUCTION).

³ All cable connections suitable for copper or aluminum.

⁴ Optional terminal ratings are available in some models - Consult Thomson Technology Power Systems.

* See last page for attribution.

Optional NEMA 3R & 4X class enclosures available - Consult Thomson Technology Power Systems.

For ATS with Distribution Breaker Option - Contact factory for dimensions.

ENCLOSURE DIMENSIONS/CABLE TERMINATIONS (ATS WITH BYPASS SWITCH)

NEMA® 1 Standard

AMPER-AGE	# OF POLES	DIMENSIONS ¹			SHIPPING WEIGHT lbs (kg)	TERMINAL RATING ²	
		HEIGHT INCHES (mm)	WIDTH INCHES (mm)	DEPTH ³ INCHES (mm)		QTY (PER PHASE)	RANGE
400A	3	80" (2032) (790)	36" (914) (566)	24" (610) (356)	955 lbs	2	#2 - 500 mcm
400A	4	80" (2032) (790)	48" (1219) (566)	22" (559) (356)	1260 lbs	2	#2 - 500 mcm
600A	3	80" (2032) (790)	36" (914) (566)	24" (610) (356)	1075 lbs	2	#2 - 500 mcm
600A	4	80" (2032) (892)	48" (1219) (693)	22" (559) (356)	1340 lbs	2	#2 - 500 mcm
800A	3	80" (2032) (1095)	36" (914) (873)	24" (610) (330)	1075 lbs	3	#2 - 500 mcm
800A	4	80" (2032) (1222)	48" (1219)(960)	22" (559) (368)	1340 lbs	3	#2 - 500 mcm
1000A	3	80" (2032) (1171)	48" (1219)(922)	22" (559) (368)	1415 lbs	4	#4 - 500 mcm
1000A	4	80" (2032) (1222)	48" (1219)(960)	22" (559) (368)	1474 lbs	4	#4 - 500 mcm
1200A	3	80" (2032) (1222)	48" (1219)(960)	22" (559) (368)	1415 lbs	4	#4 - 500 mcm
1200A	4	80" (2032) (1603)	48" (1219)(1036)	22" (559)n(368)	1474 lbs	4	#4 - 500 mcm

NEMA 3R Option

AMPER-AGE	# OF POLES	DIMENSIONS ¹			SHIPPING WEIGHT lbs (kg)	TERMINAL RATING ²	
		HEIGHT INCHES (mm)	WIDTH INCHES (mm)	DEPTH ³ INCHES (mm)		QTY (PER PHASE)	RANGE
400A	3	80" (2032) (790)	48" (1219) (566)	22" (559) (356)	1550 lbs	2	#2 - 500 mcm
400A	4	80" (2032) (790)	48" (1219) (566)	22" (559) (356)	1535 lbs	2	#2 - 500 mcm
600A	3	80" (2032) (790)	48" (1219) (566)	22" (559) (356)	1540 lbs	2	#2 - 500 mcm
600A	4	80" (2032) (892)	48" (1219) (693)	22" (559) (356)	1584 lbs	2	#2 - 500 mcm
800A	3	80" (2032) (1095)	48" (1219) (873)	22" (559) (330)	1540 lbs	3	#2 - 500 mcm
800A	4	80" (2032)(1222)	48" (1219) (960)	22" (559) (368)	1584 lbs	3	#2 - 500 mcm
1000A	3	80" (2032) (1171)	48" (1219) (922)	22" (559) (368)	1555 lbs	4	#4 - 500 mcm
1000A	4	80" (2032) (1222)	48" (1219) (960)	22" (559) (368)	1614 lbs	4	#4 - 500 mcm
1200A	3	80" (2032) (1222)	48" (1219) (960)	22" (559) (368)	1555 lbs	5	#4 - 500 mcm
1200A	4	80" (2032) (1603)	48" (1219) (1036)	22" (559) (368)	1614 lbs	5	#4 - 500 mcm

1 Enclosure dimensions are for reference. (DO NOT USE FOR CONSTRUCTION).

2 All cable connections suitable for copper or aluminum.

3 Enclosure depth shown has cable entry/exit location restrictions. Contact Factory for further detailed information.

* Enclosures painted ASA #61 Gray.

* See last page for attribution.

STANDARD FEATURES

- 2.3" back-lit LCD display for monitoring 3 Phase Utility/Generator voltage, system frequency, operation status and alarms
- Five key menu navigation
- Front panel editing with PIN protection
- Load on Utility & Load on Generator indication
- Utility & Generator Source available indication
- 3 Phase Voltage sensing on Utility & Generator Sources
- Generator AC frequency sensing
- Utility under voltage control setpoint 50 - 95%¹
- Generator under voltage control setpoint 50 - 95%¹
- Generator under frequency control setpoint 70 - 90%¹
- Engine warmup timer 0-60 min.¹
- Utility return timer 0-60 min.¹
- Engine start (Mains Transient) timer 0-30 sec.¹
- Engine cooldown timer 0-60 min.¹
- Neutral position delay timer 0-300 sec.¹
- Load Disconnect Contact (LDC) for pre/post transfer control to signal external building systems such as elevators during transfer operations
- Up to 16 different date and time scheduler for On-load or Off-load Generator Exercising
- Real-time clock provides accurate event logging
- Data logging
- Ten outputs total. Two user programmable outputs are rated at 2A, 24VDC resistive, and two user programmable output rated 15A, 24VDC resistive. Remaining contacts are for ATS functionality. The user programmable outputs can be changed to 20 different functions including: Load on Utility, Load on Gen, Load Disconnect Contact (LDC), Fail to Transfer (FTT), Utility Power Available (UPA), Generator Power Available (GPA), Utility Power Fail, ATS Not in Auto, and ATS in Auto.
- The Transfer Switch is pre-programmed with the following outputs enabled:
 - Load on Utility (UX) (15A)
 - Load on Gen (GX) (15A)
 - Load Disconnect Contact (LDC) (8A)
 - Fail to Transfer (FTT) (2A)
 - ATS Not in Auto (NIA) (2A)

¹ Settings are adjustable

² Power Metering requires Current Transformer Option Kit.



- Local and Remote utility power fail simulation test
- Engine start contact (8A, 120/240VAC resistive max.)
- Automatic force transfer to alternate supply should load voltage become de-energized
- 24VDC control power
- Remote Load Test/Peak Shave Input
- Solid Neutral on 4 Wire Systems
- Configuring System Voltage Type (3 wire delta or 4 wire Wye capable without additional sensing transformers)
- ATS Generator Bus Power Metering Capability (Amp, Volt, Freq, kW, kVA, PF)²
- Under/Over Frequency Protection - Utility and Generator Sources
- 3 Phase Over Voltage Protection - Utility and Generator Sources
- Phase Sequence and Phase Rotation Protection between Utility and Generator Sources
- Voltage Phase Loss/Unbalance Protection
- Fourteen Programmable Inputs Total (Quantity 5 User Programmable Inputs)
- Optional Remote Input module DSE2130 (Quantity 8) Digital inputs
- Optional Remote Output module DSE2157 (Quantity 8) relay contacts
- RS485 Modbus[®]* Remote Communication Port (Modbus Serial RTU)
- Optional Ethernet Modbus TCP/IP[®] Remote Communication Module DSE855 (Modbus TCP/IP)
- Optional Remote Annunciator
- Support up to Three Remote Display Unit
- Serviceable Plug-in connectors

* See last page for attribution.

TS 870 ORDERING INFORMATION

When placing an order, specify the following 21 digit ATS MODEL CODE as per the features and applications described below.

1 2 4 5 6 7 8 9 10 11 12 13 14 15 16 17 18 19 20 21

T S

8	7																		
---	---	--	--	--	--	--	--	--	--	--	--	--	--	--	--	--	--	--	--

- | | | |
|--|--|--|
| <p>1-3. SERIES
TS - TRANSFER SWITCH</p> | <p>15. VOLTAGE
1Ø 3 WIRE
D - 120/240</p> <p>3Ø 4 WIRE (GROUNDED NEUTRAL)
E - 120/208¹
F - 127/220
G - 120/240¹ (DELTA)
H - 220/380²
S - 230/400²
J - 240/416
K - 254/440
M - 277/480¹
N - 347/600¹
Y - MULTI-VOLTAGE (STOCK SWITCHES Only)¹ <i>Customer Configurable</i></p> | <p>18. UTILITY SWITCHING DEVICE
D - MOLDED CASE SWITCH DRAWOUT⁹ (400 - 1200A)
E - MOLDED CASE SWITCH DRAWOUT⁹ C/W ELECTRONIC TRIP (400 - 1200A)
F - MOLDED CASE SWITCH DRAWOUT⁹ C/W ELECTRONIC TRIP & GF (400 - 1200A)
K - MOLDED CASE SWITCH (100 - 1200A)
M - MOLDED CASE SWITCH C/W THER-MAG TRIP (100 - 200A)
N - MOLDED CASE SWITCH C/W ELECTRONIC TRIP (250 - 1200A)
P - MOLDED CASE SWITCH C/W ELECTRONIC & GF TRIP (250 - 1200A)</p> |
| <p>4 & 5. MODEL
87 - 870 SWITCH</p> | <p>16. CONTROLLER
5 - TSC 900 c/w GHC GRAPHIC DISPLAY
6 - TSC 7320 c/w LCD DISPLAY
7 - NONE (MANUAL)</p> | <p>19. GENERATOR SWITCHING DEVICE
D - MOLDED CASE SWITCH DRAWOUT⁹ (400 - 1200A)
E - MOLDED CASE SWITCH DRAWOUT⁹ C/W ELECTRONIC TRIP (400 - 1200A)
F - MOLDED CASE SWITCH DRAWOUT⁹ C/W ELECTRONIC TRIP & GF (400 - 1200A)
K - MOLDED CASE SWITCH (100 - 1200A)
M - MOLDED CASE SWITCH C/W THER-MAG TRIP (100 - 200A)
N - MOLDED CASE SWITCH C/W ELECTRONIC TRIP (250 - 1200A)
P - MOLDED CASE SWITCH C/W ELECTRONIC & GF TRIP (250 - 1200A)</p> |
| <p>6. POLES
2 - 2 POLE
3 - 3 POLE
4 - 4 POLE</p> | <p>17. ENCLOSURE TYPE
A - NEMA1, ASA #61 GRAY
B - NEMA2, ASA #61 GRAY
C - NEMA12, ASA #61 GRAY
D - NEMA3R SD, ASA #61 GRAY
E - NEMA3R DD, ASA #61 GRAY
F - NEMA3RX / 4X DD (304 STAINLESS STEEL)³
G - NONE (OPEN STYLE)
L - NEMA3RX / 4X DD (316 STAINLESS STEEL)³
X - SPECIAL</p> | <p>20. POWER CONNECTIONS
A - STANDARD
B - ATS CONNECTION PLATE 100-400A
C - ATS CONNECTION PLATE 600-800A
D - ATS CONNECTION PLATE 1000-1200A
E - ATS CONNECTION PLATE 100-400A FOR U&G
F - ATS CONNECTION PLATE 600-800A FOR U&G
G - ATS CONNECTION PLATE 1000-1200A FOR U&G
X - SPECIAL</p> |
| <p>7. CONFIGURATION TYPE
A - ATS
E - DOUBLE BYPASS - 4 BRKR⁹
X - SPECIAL</p> | <p>8 - 11. AMPERAGE
0100
0150
0200⁵
0250
0400
0600
0800
1000
1200</p> | <p>21. ATS CONNECTION CONFIGURATION³
A - STANDARD
B - ALTERNATE B (400-1200A)
C - ALTERNATE C (400-1200A)
D - ALTERNATE D (400-1200A)</p> |
| <p>12. APPLICATION
A - STANDARD
B - SERVICE ENTRANCE
C - DUAL UTILITY CONTROL
D - DUAL STANDBY GEN (Slave ATS)
H - DUAL PRIME GEN CONTROL
X - SPECIAL</p> | <p>13. OPERATION TYPE
1 - OPEN TRANSITION
2 - MANUAL ELEC. OP.
3 - CLOSED TRANSITION (MOMENTARY)⁷
X - SPECIAL</p> | |
| <p>14. SAFETY STANDARD
A - UL™ 1008 (Service Entrance)
B - CSA™ C22.2 NO 178
C - UL 1008 / CSA 178
X - NOT APPLICABLE</p> | | |

NOTES:

- 1 MULTI-VOLTAGE CAPABLE
- 2 FOR 50 Hz APPLICATION
- 3 FOR BYPASS SWITCH APPLICATIONS REFER TO FACTORY
- 5 240V MAX
- 7 CLOSED TRANSITION OPTION 400A - 1200A ONLY
- 9 DOUBLE BYPASS OPTION 400A - 1200A ONLY

AVAILABLE IN STOCK

The following standard ATS models are available from stock:

AMPERAGE	3 POLE	2 POLE OPTION (TS 872)	SERVICE ENTRANCE RATED ATS	SOLID NEUTRAL	MULTI VOLTAGE (CUSTOMER CONFIGURABLE 208-600V)	TSC 7320 CONTROLLER	NEMA@ 1 ENCLOSURE	NEMA 3R ENCLOSURE OPTION	4 PROGRAMMABLE OUTPUT CONTACTS (2A, 24VDC)	MODBUS™ RTU REMOTE COMMUNICATION PORT (SERIAL RS 485)
100A	Standard			Standard	Standard	Standard	Standard	Available Options In Stock	Standard	Standard
150A	Standard	Available Options In Stock		Standard	Standard	Standard	Standard	Available Options In Stock	Standard	Standard
200A	Standard	Available Options In Stock	Available Options In Stock	Standard	240V Max	Standard	Standard	Available Options In Stock	Standard	Standard
250A	Standard	Available Options In Stock	Available Options In Stock	Standard	Standard	Standard	Standard	Available Options In Stock	Standard	Standard
400A	Standard	Available Options In Stock	Available Options In Stock	Standard	Standard	Standard	Standard	Available Options In Stock	Standard	Standard
600A	Standard	Available Options In Stock	Available Options In Stock	Standard	Standard	Standard	Standard	Available Options In Stock	Standard	Standard
800A	Standard	Available Options In Stock	Available Options In Stock	Standard	Standard	Standard	Standard	Available Options In Stock	Standard	Standard

 Standard

 Available Options In Stock



* See last page for attribution.

OPTIONAL FEATURES (Specify separately from ATS MODEL CODE when ordering)

CODE	DESCRIPTION
<u>AUXILIARIES:</u>	
AUX-BG	Generator Bypass Auxiliary Contact
AUX-BU	Utility Bypass Auxiliary Contact
KOTS-DSE	Key Operated Test Switch - Auto/Off/Engine Start/Test - includes the DSE2130 module
RO2157	Programmable Relay Output Expansion Module - Includes QTY 8, 2A Resistive 30VDC rated relays - 4 NO and 4 Form C Contacts
PPR-10-DSE	Programmable Power Relay Includes 10A Form C Contact Wired to Terminal Block (Up to Qty 3)
TS-STG	24Vdc or 120VAC Shunt Trip Generator Switch (external power source required)
TS-STU	24Vdc or 120VAC Shunt Trip Utility Switch(external power source required)
<u>COMMUNICATION:</u>	
EMB-TCP/IP-DSE-MOXA	Ethernet Modbus®* Remote Communication (Modbus TCP)
RA7320 (DSE2548)	Remote annunciator with eight configurable LEDs. Works up to 0.6 miles from the TSC7320. Up to 10 modules can be daisy-chain (Refer to the DSE2548 Datasheet)
RD7320 (DSE2520)	Remote Display. Up to three display modules can be connected to TSC7320 (Refer to the DSE2510-20 Datasheet)
<u>ENCLOSURE:</u>	
LCK	Enclosure Lockable Door (Single point T-Handle lock)
TS-H1	Enclosure Strip Heater c/w Thermostat (120VAC external power source required)
TS-H2	Enclosure Strip Heater c/w Thermostat (internally powered from ATS load)
<u>FUNCTION:</u>	
MTS	Manually Initiated Electrically Operated Transfer Switch c/w Source Selector Switch, Position Indicating Lights, Source Available Lights
TCP	Transfer Switch Connection Plate for Generator Supply (Portable Generator Docking Supply)
TS-SS	Internal Multi-Voltage Selector Switch (208V/240V/480V)
LSC	Load Shed, 5 Stage - Requires CTK Option
<u>METERING:</u>	
LPM-DSE	Transfer Switch Load Power Metering CT Kit (Amp, Volt, Freq, kW, kVA, PF) **Requires CT Kit
CTKxxxx-DSE	Current Transformer Kit (xxxx - Specify CT Size 0100, 0150, 0250, 0400, 0600, 0800, 1200) - Requires CT Kit
MUP	Multifunction Utility Protective Relay – Basler®* BE1-11i (Protection Functions 27, 32, 47, 50/51, 67, 81O/U) <u>NOTE:</u> May be required by local utility for Momentary CT applications. Consult factory for other makes and models
<u>POWER:</u>	
SPD	Surge Protection Device
<u>OTHER:</u>	
3YR	Additional 12 Month Warranty **
5YR	Additional 48 Month Warranty **

* See last page for attribution.

** Refer to Thomson Technology Power Systems Warranty for additional details



Regal Rexnord

Customer Service: 1-888-888-0110

Sales: Thomsonps_sales@regalrexnord.com

Support: Thomsonps.support@regalrexnord.com

Regalrexnord.com/thomson

The proper selection and application of products and components, including assuring that the product is safe for its intended use, are the responsibility of the customer. To view our Application Considerations, please visit <https://www.regalrexnord.com/Application-Considerations>.

To view our Standard Terms and Conditions of Sale, please visit <https://www.regalrexnord.com/Terms-and-Conditions-of-Sale> (which may redirect to other website locations based on product family).

The following are believed to be the trademarks and/or tradename of their respective owners and are not owned or controlled by Regal Rexnord Corporation. ModBus and Modbus TCP/IP: Schneider Automation Inc.; NEMA: National Electrical Manufacturers Association; Baslet: Basler Electric Company; UL: UL LLC; CSA: Canada Standards Association; NFPA: National Fire Protection Association.

"Regal Rexnord" is not indicative of legal entity. Refer to product purchase documentation for the applicable legal entity.

Regal Rexnord and THOMSON POWER SYSTEMS are trademarks of Regal Rexnord Corporation or one of its affiliated companies.

© [2016], 2023 Regal Rexnord Corporation, All Rights Reserved. MCB-CL062r12-TPS-EN-US 10/2024

