

Photovoltaic (PV) systems on buildings

Pre-design, design, installation, and operation

Zurich Resilience Solutions – Risk Engineering



Table of Contents

1. Executive Summary	5
1.1. Important note	5
1.2. Pre-design	5
1.3. Design.....	6
1.4. Installation	6
1.5. Operation.....	7
1.6. Emergency response.....	7
2. Introduction	8
2.1. PV systems and their components.....	8
2.2. PV systems and fire likelihood vs. severity.....	9
2.3. PV systems and fire hazards	9
2.4. PV systems compared to other energy hazards.....	10
2.5. PV systems and emergency shutdown	11
2.6. PV systems and the rooftop environment.....	11
2.7. PV systems and electrical arcing.....	11
2.8. PV systems and cable connectors.....	13
2.9. PV systems and installation quality assurance.....	17
2.10. PV systems and hail	18
3. Pre-design.....	19
3.1. Develop a corporate PV system policy	19
3.2. Rooftop PV system ownership.....	19
3.3. Identify rooftop areas not to be occupied by PV systems	20
3.4. Special rooftop spacing requirements.....	21
3.5. Evaluate roof structural capacity.....	21
3.6. Evaluate the electrical system	22
3.7. Review earthquake, flood, hail, lightning, and wind exposures..	22
3.8. Consult with Zurich on recommended roof system upgrades...	24
3.9. Roof drainage and drains.....	26
3.10. Green roofs.....	26
3.11. Firewalls	27
3.12. Roof documentation for the PV system design phase.....	27
3.13. Choosing qualified persons.....	28
4. Design.....	32
4.1. Codes and standards.....	32
4.2. Zurich natural hazards data	32
4.3. Wind, seismic, and structural evaluation	32
4.4. Selection of PV system components and features.....	33

4.5.	Automatic shutdown for faults.....	37
4.6.	Rapid shutdown switch	37
4.7.	PV system fault monitoring	38
4.8.	PV system electrical requirement.....	39
4.9.	PV module placement.....	39
4.10.	Protection systems.....	43
4.11.	Design documents.....	46
4.12.	Plan submittals to Zurich	46
5.	Installation	47
5.1.	QA person qualifications and duties	47
5.2.	Installer qualifications and duties	48
5.3.	Hurricane-prone regions	49
6.	Operation	50
6.1.	Terminology	50
6.2.	PV system monitoring	50
6.3.	Contractor control program - General	51
6.4.	Contractor control program – Roof access	51
6.5.	Rooftop self-inspections	52
6.6.	PV maintenance contractor	53
6.7.	Annual infrared testing.....	54
6.8.	Change management.....	55
6.9.	Other systems - Inspection, testing, and maintenance	56
7.	Emergency response.....	57
7.1.	Fire emergency response	57
7.2.	Fault emergency response.....	59
8.	Summary	59
9.	References.....	60
9.1.	Zurich	60
9.2.	Fire Protection Research Foundation	60
9.3.	International Energy Agency	60
9.4.	NFPA	60
9.5.	TÜV Rheinland.....	60
9.6.	VdS Schadenverhütung GmbH.....	61
9.7.	Other.....	61
10.	Selected codes and standards.....	62
10.1.	International.....	62
10.2.	NFPA	62
10.3.	Europe	62

**Photovoltaic (PV) systems on buildings
Design, installation, and operation**

10.4. Germany.....	63
10.5. United States.....	65
Appendix A – Pre-design checklist.....	66
Appendix B – Design documentation checklist.....	69
Appendix C – Installation checklist.....	75
Appendix D – Commissioning checklist.....	78
Appendix E – Rooftop self-inspection checklist.....	80
Appendix F – PV maintenance contractor inspection checklist.....	81
Appendix G - PV maintenance contactor testing and maintenance checklist	84
Appendix H – PV system plan submittal checklists	86

1. Executive Summary

This document addresses PV (photovoltaic) systems installed on commercial and industrial building roofs.¹

Whether you are planning to install a PV system or already have one, this document offers insights to consider that may help reduce the likelihood or severity of a loss due to fire or other hazards such as earthquakes, hail, lightning, or wind.

For new systems, consider all the guidance offered in this document.

For existing systems, consider at least the operation and emergency response guidance.

But remember that a favorable property risk assessment outcome may depend on applying most of the measures offered in this document.

1.1. Important note

Zurich recommends installing PV systems on “favorable” roofs including limited noncombustible roofs and some combustible roofs that have a thermal barrier; however, this document includes guidance for installing PV systems on just about any roof.

Not all roofs are considered favorable for installing PV systems. Where it is necessary to install PV systems on unfavorable roofs, the PV system may adversely affect Zurich’s assessment of the location.

1.2. Pre-design

The pre-design phase offers an opportunity to consider measures that may reduce loss severity. The following are some selected measures to consider.

- Develop a corporate policy to guide a consistent long-term approach to managing PV systems.
- Manage contacts for rooftop PV systems that others will own so the guidance of this document may be applied throughout the PV system life cycle.
- Identify roof areas that PV systems should not occupy.
- Have a structural engineer evaluate the selected roof to determine whether it is a PV system candidate.
- Consult with Zurich to determine the hazard levels for perils such as earthquakes, hail, lightning, and wind.
- Have an electrical engineer evaluate the building's electrical system and utility service to consider needed upgrades for a PV system.

¹ Wall-mounted PV systems appear to be less common than rooftop systems as they may be more costly to mount and may offer limited energy production from the available space on south-facing facades.

- Consult with Zurich on recommended roof upgrades before installing a PV system.
- Select contractors with a proven track record for designing and installing PV systems.

For further insights on the above, see Chapter 3 of this document.

1.3. Design

The design phase offers an opportunity to consider measures that may reduce loss likelihood. The following are selected measures to consider.

- Follow all local electrical, building, and fire codes
- Selection of PV system components and features
 - Select a PV system using either microinverters, dc-to-dc converters (an example of the dc-to-dc converter is the power optimizer), or string inverters.
 - If the PV modules are not expected to be immediately plugged in upon installation, have the PV modules shipped with protective caps on each connector
- PV module placement
 - Avoid PV systems in areas excluded during the pre-design phase
 - Apply Zurich array size and spacing recommendations
- Provide protection systems
 - For all PV systems
 - Fire detection system
 - Surge protection
 - For PV systems as recommended in the pre-design phase:
 - Fixed fire protection system
 - Lightning protection system

For further insights on the above, see Chapter 4 of this document.

1.4. Installation

The installation phase offers an opportunity to consider measures that may reduce loss likelihood. The following is one selected measure to consider.

- Hire a third-party quality assurance person to monitor the PV system installation and commissioning and verify compliance with the design documents.
- Install an ideal example, a “golden row,” of PV modules to provide a reference for installation teams and inspectors (see section 2.9.2)

For further insights on the above, see Chapter 5 of this document.

1.5. Operation

The operation phase offers an opportunity to consider measures that may reduce loss likelihood. The following are some selected measures to consider.

- Hire a qualified contractor to conduct periodic PV system service.
- Implement an in-house roof access control program.
- Implement an in-house rooftop inspection program.
- Implement a change management program to address changes, expansions, or decommissioning of the PV system and other roof installations.

For further insights on the above, see Chapter 6 of this document.

1.6. Emergency response

The emergency response phase considers measures that may reduce loss severity. The following is one selected measure to consider.

- Invite the local public fire service and PV system contractor to develop a pre-fire plan that includes the operation of the PV rapid shutdown system (for more information, see section 4.6).

For further insights on the above, see section 7.1.2 of this document.

2. Introduction

Solar energy has established itself as a sustainable energy source in recent years. The installation of PV systems on rooftops continues to increase.

However, rooftop PV systems present perceived challenges, and this chapter reviews several of these perceived challenges.

2.1. PV systems and their components

The direct use of the energy radiated by the sun using PV systems complements other traditional energy generation sources.

PV modules come in various styles, including standard rigid glass, flexible, and roof tile modules. This document addresses rigid modules.

A PV system often consists of PV modules, rapid shutdown equipment, inverters, disconnect switches, surge protection, and metering equipment. In addition, the system has direct current and alternating current cables. The following diagrams offer schematic views of three possible public utility grid-connected PV system configurations (inverters shown in gray).

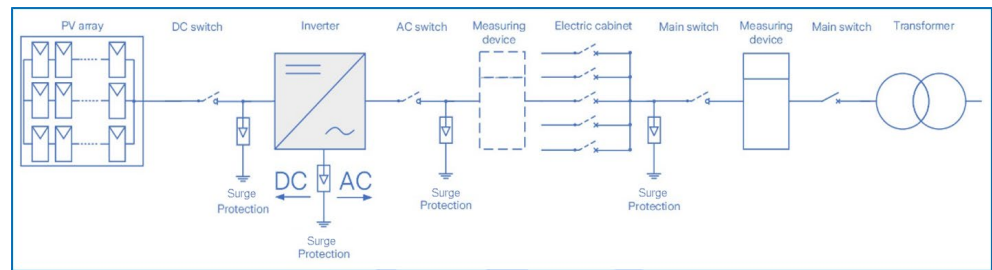

Schematic of a central inverter PV system (no microinverters or dc-to-dc converters (optimizers), and multiple arrays connected to the inverter) connected to a public utility power grid. (Source: ZRS)

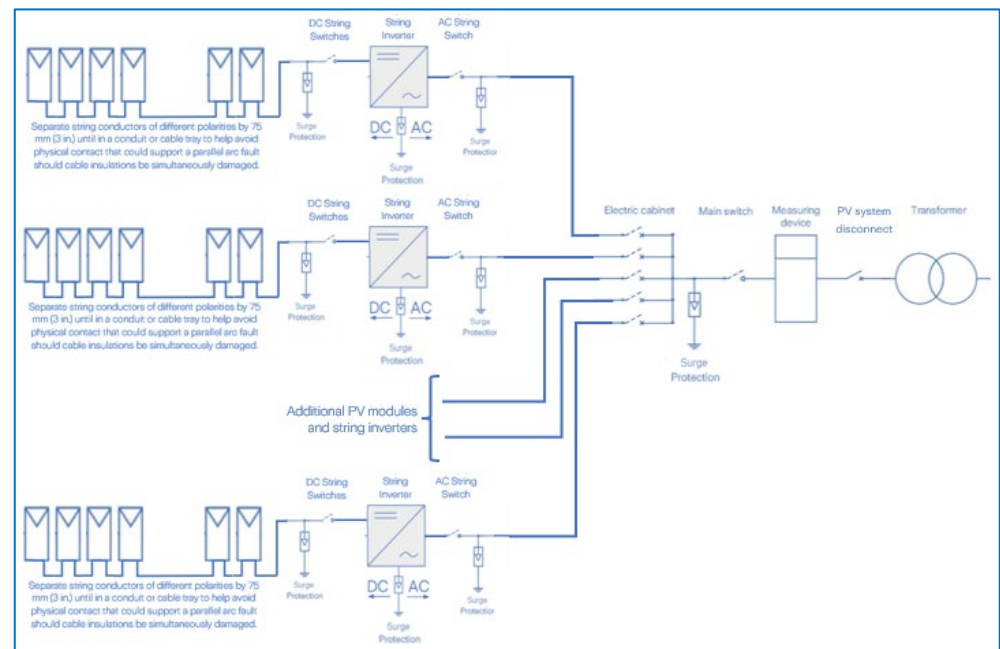

Schematic of a string inverter system (no microinverters and no dc-to-dc converters (optimizers)) with one array connected to each inverter. All inverters are connected to a public utility grid. (Source: ZRS)

Photovoltaic (PV) systems on buildings
Design, installation, and operation

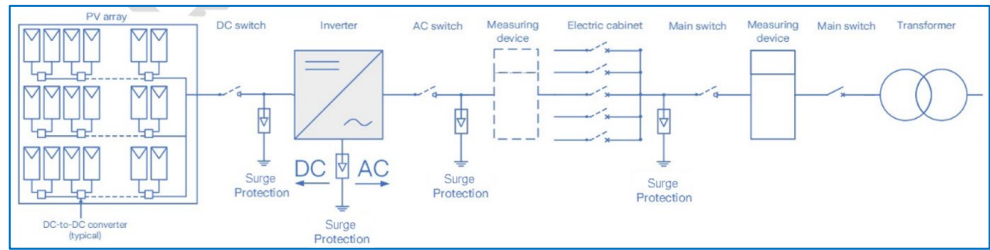

Schematic of a PV system with dc-to-dc converters (optimizers) connected to a public utility power grid. (Source: ZRS)

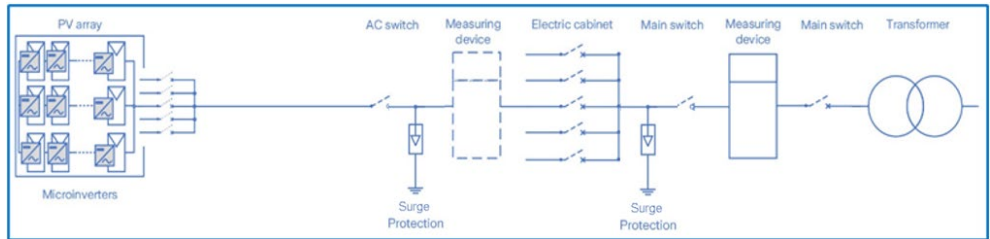

Schematic of a PV system with microinverters connected to a public utility power grid. (Source: ZRS)

2.2. PV systems and fire likelihood vs. severity

Throughout this document, there is a discussion of measures that may reduce the likelihood of a rooftop PV fire and actions that may reduce the severity of a rooftop PV fire should one occur.

As indicated in the following graphic, the likelihood of rooftop PV fires relates to installation quality and management, while fire severity relates to roof combustibility.

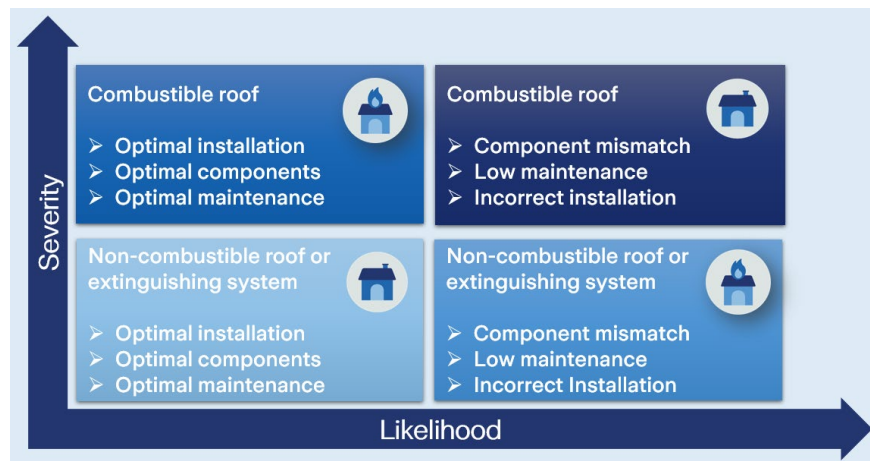

Examples of factors that may affect the severity vs. likelihood of PV system loss. (Source: ZRS)

2.3. PV systems and fire hazards

Fire hazards associated with PV systems may include:

- Wiring faults (e.g., such as loose connections and bad connectors) accompanied by overheating or arcing
- PV modules (panels) or other components overheating or failing

- Inverter failures with overheating or failure of components

Overheating and arcing may develop for several reasons, such as:

- Installation errors
- Product failures
- System damage
- System aging or deterioration

PV systems may be exposed to damage by natural hazards such as earthquakes, flood, hail, lightning, and wind. These hazards may cause physical damage to the system, and the physical damage may lead to faults that may include ensuing fire.

By understanding the hazards associated with a PV system and implementing the recommendations outlined in this document, it may be possible to reduce the chance of a rooftop PV system fire, and should a fire occur, it may be possible to reduce the severity of the resulting damage.

2.4. PV systems compared to other energy hazards

Buildings and businesses need energy. Traditional sources of energy include:

- Normal power from electrical rooms
- Back-up power from generator rooms
- Steam or hot water from boiler rooms

These energy sources are typically housed in fire-rated rooms to separate the higher-hazard source from other building areas.

However, with rooftop PV systems, the higher-hazard energy source (the PV system itself) is not necessarily isolated from the other building areas. Consider that a building roof may or may not have an hourly fire resistance rating (e.g., a 1-, 1.5-, or 2-hour fire resistance rating).

A common rooftop PV fire scenario

A rooftop PV fire occurs. The fire spreads as it consumes combustible elements of the building roof system such as the roof cover.

The fire service responds and controls the fire with water. The fire damage is contained to the affected rooftop area.

But as the fire has damaged the building roof cover, firefighting water magnifies the loss as it spread down into the building below.

Often the water damage and business interruption inside the building may be greater than the fire damage on the rooftop above.

2.5. PV systems and emergency shutdown

Conventional energy sources are subject to faults that may lead to fires. However, protection guidelines have developed over time that include controls intended to interrupt a conventional energy source before it may develop into a fire. These may consist of automatic shutdown interlocks or manual emergency shutdown switches.

With rooftop PV systems, the system may generate power if there is light. So, while PV system disconnect switches may be operated (opened), stopping the PV modules from generating power may not be possible.

If there is light, a PV system may remain an active source of energy.

2.6. PV systems and the rooftop environment

The building roof offers an ideal location for a PV system. The roof is often an unused area exposed to direct sunlight.

While most rooftops have some degree of electrical equipment, installing a PV system will likely significantly increase the amount of rooftop electrical equipment.

However, the rooftop presents a harsh environment for electrical equipment. The rooftop may expose electrical equipment to:

- Thermal stresses associated with cyclic temperatures
- Corrosion associated with humidity and precipitation
- Damage due to vermin such as insects, rodents, and birds
- Damage due to natural hazards such as hail, lightning, and wind
- Damage due to other trades working on the roof and rooftop equipment and disturbing components of the PV System

So, any rooftop PV system will need frequent and ongoing inspections to detect damage or deterioration. And identified issues will need timely maintenance to reduce the likelihood of fires.

2.7. PV systems and electrical arcing

Any electrical system may experience a phenomenon called “arcing.”

Arcing occurs when there is a gap in an electrical current flow path. The gap may be due to a connection failure or a wire break, or it may form between a point of damaged wire insulation and a nearby piece of grounded metal.

Arcs primarily occur when a normal circuit is interrupted or when an inadvertent circuit is formed (such as grounded metal) and that inadvertent circuit is interrupted. Voltage may build up at the location of the gap until it ionizes the air within the gap. This means the air molecules in the gap become conductive. Once the air is ionized, an electric arc may form across the gap. These arcs are more common with dc circuits since the voltage is

stable. Ac arcs are less stable and take considerably more voltage to sustain the arc.

2.7.1. Alternating current (ac)

An advantage of ac is that the voltage level is cyclic and will drop to zero as it cycles. While the ionized air may persist at a circuit gap, and arc could re-establish itself, it will continue to be extinguished when the voltage once again drops to zero. In general, it is unlikely that an ac arc would be sustained.²

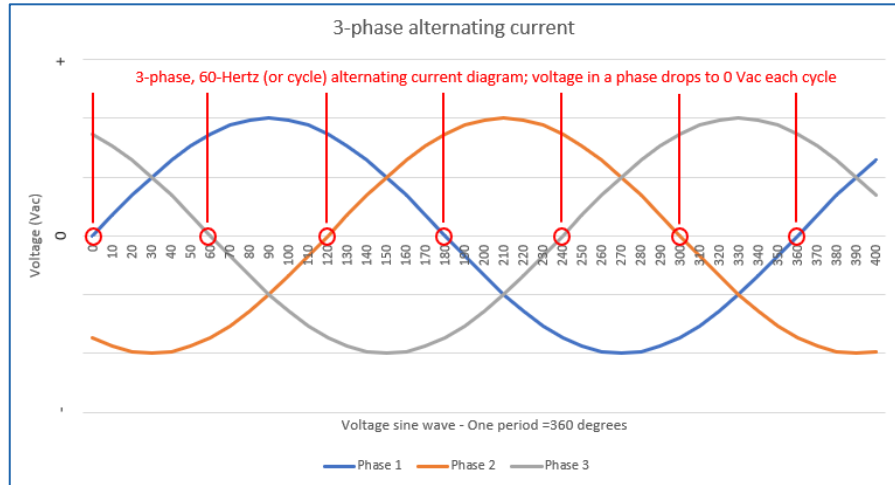

Diagram of alternating current showing a phase at 0 Vac each cycle (this diagram shows a 60 Hz cycle, and 50 Hz would be similar. (Source: ZRS)

Microinverters - PV systems using microinverters are designed to limit dc to the PV module level.

2.7.2. Direct current (dc)

Unlike ac, a dc arc, once formed, may be persistent and difficult to interrupt. Such arcs tend to generate extreme heat that may cause a fire.

Dc-to-dc converters- PV systems using dc-to-dc converters (including optimizers), will have the converters arranged in series to develop dc voltages up to 1,000 Vdc. Such systems include arc and ground fault detection to automatically signal the converters to shut down the high-voltage dc strings, allowing high-voltage dc arcs to be extinguished downstream of the converters.

Central and string inverter systems without dc-to-dc converters - PV systems using central or string inverters without dc-to-dc converters (such as optimizers) will have the PV modules arranged in series to develop dc voltages up to 1,000 Vdc on buildings. Such systems include arc and ground fault detection to shut down the inverter automatically. Still, the inverter shutdown action may not interrupt all types of dc arc faults such as parallel arc faults and arcs related to multiple ground faults.

²See the reference in section 9.5, "Assessing Fire Risks in Photovoltaic Systems and Developing Safety Concepts for Risk Minimization".

2.7.3. Arc-fault objectives

With the PV systems, the arc-fault objectives include:

- Reducing the likelihood of arc faults – Measures to reduce the possibility of arc faults are discussed further in Chapter 4, Design, and Chapter 5, Installation
- Monitoring and responding to arc faults – Measures to monitor and react to arc faults are discussed further in Chapter 6, Operation.

2.8. PV systems and cable connectors

Rooftop PV systems may involve several kilometers (miles) of cable and thousands of cable connectors. Connectors have been identified as familiar sources of PV systems fires.

PV connectors are one of the common sources of PV system fires

Source: Jomaas, Grunde. “REPowerEU presents big challenges with respect to PV fire safety.” International Fire Protection. September 2022.

Connector listing - Each cable connection consists of a male and female pair. Use connectors that are listed by a Zurich Recognized Testing Laboratory. Examples of Zurich Recognized Testing Laboratories include TÜV, UL, and VDE.

Connector mating - Verify that the two connector halves to be mated are made by the same manufacturer and are of the same type. If they are from the same manufacturer but not the same type, obtain documentation from the manufacturer that the two types are acceptable for use together.

Connector mismatch - Where any materials (such as PV modules) received at the project location does not comply with the design documents and introduce a connector mismatch, the recommended action is to return the noncompliant product for replacement products fitted with compliant connectors. Possible alternatives may include:

- Having the PV module manufacturer field-replace the mismatched connectors
- Having the PV module manufacturer give permission for the installer to field-replace the mismatched connectors

Connector protection in the field - If connectors are not to be plugged in (mated) immediately upon installation, then provide protective connector caps on each unmated connector.

The connectors on an optimizer may be snapped together to form a weather-tight connection until they are to be connected into their final designed circuits. However, this approach of snapping connectors together should be used sparingly with connectors on PV modules leads as the short

circuited module may experience internal damage to the connectors if they are opened under sunlight.

Wrapping unmatted connects with electrical tape is not considered protection as there is no certainty the wrapping will be complete and effective. In addition, there may be an adverse chemical interaction between the electrical tape adhesive and connector contacts.



Example of an unprotected connector that has been contaminated (Picture/Illustration of Stäubli, Switzerland)



Examples of protective connector caps (Picture/Illustration of Stäubli, Switzerland)



Example of a PV modules with unmatted connectors with protective caps (Picture/Illustration of Stäubli, Switzerland)

See section 4.4.4 for further discussion on the storage and handling of PV modules.

Connectors and field-fabrication - Each string of PV modules will include at least two field-fabricated cables of the appropriate length to connect the PV string circuit to a junction box, combiner box, or inverter. These cables will need to be fitted with connectors. To reduce the likelihood of arc faults and ensuing fires at these connectors, qualified installers need to follow manufacturers' instructions and use manufacturer-specific tools to install

Photovoltaic (PV) systems on buildings
Design, installation, and operation

the field-fabricated connectors. Manufacturer-specific tools may include cable insulation strippers, terminal crimping tools, connector housing torque wrenches, and associated assembly tools. While the manufacturer-approved tools may be expensive, improper installation of field-fabricated connectors has caused losses in hundreds of installations, making this issue a common cause of PV system fires.



Example of manufacturer's tool (Picture/Illustration of Stäubli, Switzerland)

Focus on the PV connectors

As noted earlier, PV connectors are a common source of PV system fires. As such, they deserve a very high level of attention.

During the design phase:

- Verify that the design documents only allow the mating of connectors of the same manufacturer and type.
 - If the connectors are from the same manufacturer but are of different types, obtain documentation from the manufacturer that the two types are acceptable for use together
 - If the connectors are from different manufacturers, do not allow their use together regardless of any intermatability claims
- Verify that the design documents specify the same make and type of connectors between:
 - Microinverters or optimizers and the PV modules
 - Microinverters or optimizers and the field-assembled homerun cables

During the installation phase:

- Verify that the installer reviews all received products and that the connectors delivered comply with the design documents.
- Verify that the independent, third-party quality assurance person verifies that the installed connectors comply with the design documents.

Connector additional considerations - When selecting connectors, consider criteria such as electrical voltage and current ratings, dust- and liquid-tightness, protective rating for ultraviolet (UV) light, and the mechanical integrity of the connector.

When PV connectors are listed by a Zurich Recognized Testing Laboratory, their dust- and liquid-tightness will typically be at least IP65, if not higher.

Connector dust- and liquid-tightness ratings

IEC 60529, Degrees of Protection Provided by Enclosures (IP Code), which has superseded IEC 529, establishes ingress protection (IP) ratings for electrical enclosures, including PV connectors. The ratings are in the format of IP(S)(L) where (S) is the rating against solids intrusion and (L) is the rating against liquids intrusion. The following table outlines the rating scale.

Rating	Solids	Liquids*
0	No protection	No protection
1	Solids >50mm	Fall drops
2	Solids >12 mm	Fall drops enclosure tilted 15°
3	Solids >2.5 mm	Water spray at an angle up to 60°
4	Solids >1 mm	Water splash from any direction
5	Dust protection	Water jet from any direction
6	Dust-tight	Powerful water jet from any direction
7	Not used	Temporary immersion
8		Continuous immersion
9		Water projected at high pressure and temperature from any direction

*Any water intrusion that does occur during a test is not to have harmful effects.

Table source: “IP ratings”, IEC, <https://www.iec.ch/ip-ratings>

2.9. PV systems and installation quality assurance

A PV system may include several hundred or even several thousand PV modules. This means installation may become a repetitive process for the workers involved. Mistakes may happen as modules are handled, installed, or connected.

2.9.1. Independent, third-party quality assurance person

Provide installation and commissioning oversight by providing an independent, third-party quality assurance person to help identify and correct installation errors before the project is complete.

2.9.2. Golden row³

As a guide to the repetitive installation process, start the project by installing a “golden row” of PV racking, cabling, and modules. Install the “golden row” as follows:

- Under the supervision of the installer and third-party quality assurance person
- In strict accordance with the design documents
- Near the job roof access point for daily viewing by all workers
- Contain all necessary measures to ensure that the cable management is done correctly with no cables exposed to physical damage
- PV modules are installed in their supports properly with all necessary hardware, including all equipment grounding and bonding devices required by the project

The “golden row” concept offers all workers an ever-present example of the correct installation for that project at the job site. If new workers join the team, the “golden row” is available for their introduction to the project.

2.10. PV systems and hail

Locations with a moderate or higher Zurich hail rating may be exposed to hailstorms that exceed the most hail-resistant PV modules commercially available today. Zurich anticipates the potential for significant hail damage in such areas.

³ See the reference in section 9.7, “Taking ownership of your new solar project: is that in-service date realistic?”

3. Pre-design

The pre-design phase will involve a discussion with your Zurich account team. It will offer an opportunity to consider if a rooftop PV system should be pursued and, if pursued, measures to consider that may help reduce the severity of any loss that may occur during the PV system's life.

The pre-design phase is a time to:

- Consider developing an internal corporate policy on PV systems
- Consider who will own the system
- Identify any rooftop areas that a PV system should not occupy
- Evaluate a roof's structural capacity to support a PV system
- Evaluate the building's electrical system and utility service
- Consult with Zurich on hazards related to hail, lightning, and wind
- Consult with Zurich to identify any recommended roof upgrades
- Select qualified persons for the PV project

See Appendix A for a checklist of items to consider during the pre-design phase.

3.1. Develop a corporate PV system policy

Consider developing an internal corporate policy to guide a consistent long-term approach to managing PV systems throughout their life cycle.

The policy should consider measures offered throughout this document. Specifically, the policy should address the following phases of a PV system's life:

- Pre-design
- Design
- Installation
- Operation
- Emergency response

3.2. Rooftop PV system ownership

A building owner may choose to own a proposed rooftop PV system, or they may opt to lease the rooftop to a third party who will own the system.

Consider the contract terms and conditions when leasing a rooftop to a third party. In particular, consider how the terms and conditions may impact the ability to implement the guidance of this document throughout the PV system's life cycle.

Realize that a PV system contract that supersedes the ability to benefit from the guidance of this document may adversely affect the Zurich risk assessment of the involved location.

3.3. Identify rooftop areas not to be occupied by PV systems Consider identifying roof areas that PV systems should not occupy.

3.3.1. Indoor operations that may need venting through the roof

Consider keeping PV systems away from rooftop areas above equipment or operations that need to penetrate the roof for ventilation or other reasons. For example:

- Fuel-fired equipment, including boilers, ovens, and furnaces
- Ignitable liquid operations such as paint spray booths, ignitable liquid process areas, combustible dust process areas, and ignitable liquids storage rooms
- Other equipment that needs ventilation through the roof, such as laboratory hoods

Consider future process changes or additions that may introduce the need for new or relocated roof penetrations.

Consider exhaust vents that involve ignitable liquid vapors or particulates. Such vents should generally be kept at least 3 m (10 ft.) from PV systems. However, consider all existing vents during the design phase. Take note of rooftop debris fallout from roof vents to identify areas to avoid and reduce excessive soiling of the PV array surface.

New ignitable liquids process area

A business with a rooftop PV system introduced a new, interior, ignitable liquid storage room that included dispensing. The room needed ventilation.

As the roof above the new room was occupied by the PV system, ventilation through the roof was not considered an option.

The proposed alternative was a horizontal exhaust duct

3.3.2. Water susceptible operations below a roof

Consider keeping PV systems away from rooftop areas above high-value or business-critical operations (including machinery and equipment) or essential stock.

Remember that a PV fire will likely damage the roof cover (the waterproofing membrane). Once the roof cover is damaged, firefighting water will likely follow the path of least resistance and flow down into the building area below.

Rooftop PV fire experience shows that the water damage in the building below is often more costly than the fire damage to the PV system and roof.

So, consider the contents and stock that may be exposed to water damage below a proposed PV system. Evaluate the potential business interruption due to water damage to essential process equipment or critical inventory.

ASRS (automatic storage and retrieval system) warehouse

A rooftop PV system was installed above the machinery handling the flow of goods into and out of an ASRS warehouse. A fire occurred involving the PV system above that machinery.

The rooftop fire damaged the roof cover and firefighting water flowed down into the building below. The ASRS machinery was damaged by the firefighting water.

As the ASRS warehouse handled all raw materials and finished goods, all business was interrupted until the water damaged machinery was repaired.

3.3.3. High hazard occupancies

Consider keeping PV systems away from rooftop areas above high-hazard occupancies (existing or planned), such as areas storing, handling, or using ignitable liquids, flammable gases, combustible dust, or other hazardous materials.

Should a rooftop PV fire occur, the firefighting challenge may be magnified by the hazardous occupancy below.

3.4. Special rooftop spacing requirements

Local codes and standards may include various rooftop PV system spacing requirements such as:

- Minimum PV array distance from roof edges for firefighter rooftop access
- Minimum walkway sizes and locations for rooftop firefighting
- Minimum walkway size and access around smoke and heat vents

Consult with your local fire service to determine if they have any local regulations or specific requests regarding rooftop access for firefighting. Remember, the local fire service will determine how quickly (or if) they will fight a rooftop PV system fire.

Also, consult with your facilities manager or rooftop equipment maintenance contractors for their guidance on the space needed around specific rooftop features or equipment. The objective is to facilitate service and maintenance work and reduce the likelihood of PV system damage during such work.

3.5. Evaluate roof structural capacity

When considering a PV system, consult a structural engineer to evaluate if the selected roof has sufficient structural capacity for a PV system.

If the structural engineer determines the roof cannot handle the loads associated with a PV system, you may wish to avoid pursuing a PV system for that roof.

If the structural engineer determines the roof is a candidate for a PV system, there is still a need to analyze the actual PV system loads, wind resistance, and earthquake resistance (if exposed) during the design phase.

3.6. Evaluate the electrical system

When considering a PV system, consult an electrical engineer to evaluate the building's electrical system and utility service. This may provide an opportunity to consider any needed upgrades for a PV system.

3.7. Review earthquake, flood, hail, lightning, and wind exposures

When considering a rooftop PV system, contact Zurich to review the natural hazard exposures at the location where the PV system is to be installed.

Zurich uses global hazard maps for earthquakes, floods, hail, lightning, and wind in addition to local hazard maps where available.

3.7.1. Earthquake

At locations where Zurich rates earthquake high or very high, consider having a qualified structural engineer evaluate the rooftop PV system during the design phase for its ability to resist horizontal and vertical earthquake loads.

3.7.2. Flood

Consult with Zurich to identify flood hazards where the PV system will be installed. Flood hazards may include:

- Pluvial (or surface water) flood - Overland flooding from rainstorms
- Fluvial (or riverine) flood – Water body overflow
- Storm surge - Coastal flooding due to tropical cyclones or hurricanes

The intent is to use flood data for the location where the PV system is to be installed to guide the PV system designer during the design phase so all PV system components may be located beyond identified flood zones or, as a minimum, located above anticipated flood water elevations.

3.7.3. Hail

At locations where Zurich rates hail medium, high, or very high, consider selecting PV modules certified for hail. In these cases, select the highest hail testing requirements of either IEC 61730⁴ or UL 61730⁵.

Realize that locations in moderate, high, or very high-rated hail zones may be exposed to hailstorms exceeding the most challenging hail test requirements in either IEC 61730 or UL 61730. Beyond others, such areas

⁴ IEC 61730 is the Photovoltaic (PV) module safety qualification standard. It includes Part 1” Requirements for Construction, and Part 2: Requirements for Testing. This is a global standard applied outside the US.

⁵ UL 61730 is the Photovoltaic (PV) module safety qualification standard. It includes Part 1” Requirements for Construction, and Part 2: Requirements for Testing. This document has been harmonized with IEC 61730 and is applied in the US. It is aligned with NFPA 70, National Electrical Code.

may be found in north-central Argentina, the east coast of Australia, and the central and southeast United States. The potential for significant hail damage should be expected in such areas.

3.7.4. Lightning

Where a PV system is to be added to a building equipped with a lightning protection system, extend the lightning protection system to include the PV system.

At locations where Zurich rates lightning high or very high, consider installing lightning protection to protect both the building and the PV system.

Design lightning protection systems following a Zurich Recognized Protection Principle such as IEC 62305⁶, NFPA 780⁷, or VdS 2031⁸.

Lightning damage may be due to a direct strike, or a surge associated with an indirect strike. In either case, the operation of the PV system may be interrupted for an extended period while the extent of damage is assessed and repaired. And remember that the PV system damage could develop into faults that lead to an ensuing PV system fire.

Lightning protection

Zurich rates the lightning exposure as high when a location is exposed to 11 to 20 lightning flashes per square kilometer per year.

Surge protection

Surge protection is recommended for all PV systems (see section 4.10.2). Surge protection is addressed in the Zurich Recognized Protection Principles for lightning protection (IEC 62305, NFPA 780, and VdS 2031).

3.7.5. Wind

Consult with Zurich to determine the recommended design wind speed for locations where PV systems are planned. Then, during the design phase, request designers to develop wind load calculations based on a design wind speed that meets or exceeds the Zurich recommendation.

The objective is to avoid the movement of PV system components. The movement of PV modules or their supporting racks may damage PV modules. Such damage may lead to module heating and ensuing fires.

⁶ IEC 62305 is Protection Against Lightning. It includes Part 1: General Principles, Part 2: Risk Management, Part 3: Physical Damage to Structures and Life Hazard, and Part 4 Electrical and Electronic Systems Within Structures

⁷ NFPA 780 is Standard for the Installation of Lightning Protection Systems.

⁸ VdS 2031 is Lightning and surge protection in electrical installations

Movement may also strain PV cables. Such strain may damage cable connectors or cable insulation, potentially leading to arc faults and ensuing fires.

High wind regions - For locations subject to tropical cyclones or hurricanes, select a stand-mounted PV system rather than a ballasted PV system. The concern is that these locations may be subject to very high winds. PV systems mechanically attached to the building structure may perform better than ballasted systems in these areas.

3.8. Consult with Zurich on recommended roof system upgrades
When considering a rooftop PV system, contact Zurich to discuss the roof system where the PV system is to be installed.

Roof warranty

It may be helpful to review roof warranties for any provisions that may affect the PV system installation.

For new or existing buildings, submit available roof information to Zurich, such as:

- Layer-by-layer description of the roof system (waterproofing membrane, cover board (where provided), insulation, and deck), along with product literature for each component
- Roof drawings showing the location of all roof penetrations and rooftop equipment
- Roof details showing the arrangement of roof penetrations and rooftop equipment

For existing buildings, the discussion may lead to recommended upgrades to existing roofs before the PV system is installed.

For new buildings, the discussion may lead to recommended modifications to the planned roof system.

3.8.1. Roof covers, insulations, and decks

With regards to roof systems, consider the following.

Roof system life - A rooftop PV system may have an expected life approaching 25 years. So, the age or life expectancy of the roof system should be evaluated.

For existing roof systems, consider upgrading the roofing system to have a life expectancy like or exceeding the PV system's life expectancy. This may help avoid prematurely removing a rooftop PV system for roof system repairs or replacement.

Polystyrene roof insulation – Avoid installing a PV system on a roof with expanded or extruded polystyrene insulation unless the roof system is an FM Global Approved Class 1 roof.

Polystyrene roof insulation

Expanded and extruded polystyrene are fast-burning materials. Where buildings use polystyrene insulation in walls, ceilings, or roofs, it is likely the location will be assessed harshly for the peril of fire.

[Polyurethane roof insulation](#) - Install a thermal barrier where a PV system will be installed on a roof system that includes polyurethane insulation (except for metal-faced composite panels with a polyurethane core).

Polyurethane vs. polyisocyanurate roof insulation

Polyurethane roof is combustible and may contribute to rooftop fire spread.

Based on observed Zurich and industry fire experience, the need for a thermal barrier does not apply to polyisocyanurate roof insulation. This view may be modified as large-scale fire test research is completed by the NFPA Research Foundation.

[Wood roof decks](#) – Where a PV system is to be installed on a roof system that includes a wood roof deck, install a thermal barrier.

[Thermal barriers](#) – Materials viewed as suitable thermal barriers may help avoid a rooftop fire from involving the roof systems materials below the thermal barrier during the time it takes for the local fire service to respond and achieve final fire extinguishment.

Extend the thermal barrier at least 2.5 m (8 ft.) beyond all PV system components.

Thermal barriers that may be installed immediately below the roof membrane include:

- Fiberglass mat-faced gypsum board at least 6 mm (0.25 in.) thick
- Compressed mineral wool roof board (e.g., mineral fiber roof board at least 6 mm (0.25 in.) thick with a density of 100 kg/m³ (6 lb./ft³)).

Additional materials that may be installed above a roof membrane include:

- Concrete or mineral pavers at least 4 cm (1.5 in.) thick
- Vegetative roof substrate at least 5 cm (2 in.) deep
- Gravel at least 5 cm (2 in.) deep using gravel 16 to 40 mm (0.5 to 1.5 in.) in size

Note: Some high-wind regions may not allow the use of gravel.

Thermal barriers

A rigid thermal barrier installed below a roof membrane has been viewed as a favorable feature to help protect the service life of a roof system by several Zurich customers.

The concern is with the increased rooftop foot traffic expected when a rooftop PV system is installed.

The benefits of a rigid thermal barrier under the membrane may include:

- Protecting the rigid roof insulation board by distributing loads associated with foot traffic.
- Protecting the roof membrane by providing it added rigid support.

3.8.2. Roof penetrations

Roof penetrations include:

- Smaller features like expansion joints, seismic joints, roof drains, plumbing vents, and similar penetrations
- Larger features like skylights, smoke and heat vents, mechanical equipment, and similar equipment

Fill gaps around each roof penetration using a non-combustible material like mineral wool or fire-rated caulk. Avoid combustible materials such as foam-in-place fillers. Where combustible fillers are present, replace them with noncombustible fillers.

Note: The use of wood roof nailers at expansion joints and curb-mounted HVAC equipment is acceptable.

3.9. Roof drainage and drains

The roof drainage and roof drains are needed to remove rainwater from rooftops. Roof drainage is the roof slope that carries rainwater to the roof drains. Roof drains are the features that remove rainwater from a roof. Roof drains should include primary and secondary drains for redundancy and unexpected severe rain events.

When installing a PV system, a design objective should be placing all PV system components on the roof in a manner that will not disrupt roof drainage paths or roof drains. To support this design objective, locate or develop a drawing showing the rooftop drainage and rooftop drains for use by the PV system designer.

3.10. Green roofs

With regards to green roofs, consider the following.

- Provide a roof membrane maintenance program that follows the manufacturer's instructions.

- Maintain at least a 0.3 m (1 ft.) horizontal space between PV system components and extensive vegetation. In addition, maintain at least a 5.0 m (15 ft.) horizontal space between PV system components and intensive vegetation.
 - Note 1: Extensive vegetation is not more than 200 mm (7 in.) tall.
 - Note 2: Intensive vegetation is more than 200 mm (7 in.) tall.
 - Note 3: The above spacing guidance applies to all PV system components, including PV modules, PV junction boxes (combiner boxes), inverters, cables, and cable enclosures (raceways).
 - Note 4: Consult with Zurich for any deviations.
- Have a qualified person determine the soil substrate depth and type to support healthy vegetation.
- Provide monthly inspections to verify vegetation health, soil moisture levels, testing of irrigation systems, and maintenance needs.
- Provide maintenance (such as watering, weed removal, plant replacement, or irrigation system repairs) as identified during monthly inspections.

Water vegetation as needed to help avoid dried vegetation, especially during droughts or hot weather. Consider a fixed irrigation system. For locations exposed to cold weather, protect the irrigation system from frost damage.

3.11. Firewalls

Identify the location of firewalls. Firewalls are designed to have both a fire-resistance rating and structural stability when exposed to a fire. These walls will typically include a parapet extending up through the roof system.

When installing a PV system, a design objective should be placing all PV system components to keep them away from firewalls. See section 4.9.2 for further insights. To support this design objective, develop a drawing showing the location of firewalls for use by the PV system designer.

3.12. Roof documentation for the PV system design phase

Prepare roof documentation for use by the PV system designer during the design phase.

The roof documentation should include the following:

- Zurich natural hazard data including:
 - **Flood** – Exposures to any flood hazard along with any available estimated water elevations, in a diagram or written description, for areas where PV system components may be installed.
 - **Hail** – Exposures where the Zurich hail rating is medium, high, or very high.
 - **Lightning** – Exposures where the Zurich lightning rating is “high” or “very high.”

- Wind – The Zurich recommended minimum design wind speed.
- Layer-by-layer description of the roof system (waterproofing membrane, thermal barrier (where provided), cover board (where provided), insulation, and deck), including product literature for each component.
- Roof drawings (as-built) showing the location of the following as applicable:
 - Rooftop areas not to be occupied by PV system components.
 - Special spacing requirements for fire service roof access or rooftop equipment service and maintenance.
 - Rooftop areas for vegetation (green roof areas).
 - Roof penetrations with confirmation of non-combustible fill where verified.
 - Rooftop equipment, including skylights.
 - Roof elevation changes.
 - Firewalls, along with their parapet height above the roof surface.

3.13. Choosing qualified persons

A rooftop PV system may be a turnkey project where one contractor performs the design, installation, commissioning, and maintenance. Or the system owner may hire separate contractors for various steps. In either case, contractors will be involved, and their qualifications should be considered as they are selected.

In addition to the designer and installer, consider hiring an independent, third-party quality assurance person to monitor the installation and commissioning of the PV system. Remember, the PV system will be generating power on the building roof. The electrical hazards associated with the system will not be isolated in a fire-rated electrical room or generator room. Instead, any electrical fault may lead to a fire that may directly threaten the building and the associated business operations underway inside. The intent of the independent, third-party quality assurance person is to help reduce the likelihood of a fire involving the rooftop PV system.

Ask each contractor or quality assurance person being considered to submit an outline of their qualifications that may include the following:

- General electrical qualifications
- PV system-specific qualifications
- Relevant work experience and references

3.13.1. General electrical qualifications

Across the world, there is no single set of qualifications or certifications for a PV system designer or installer. A minimum requirement may involve at least one person involved with a project who is an electrical engineer with professional standing or a qualified electrician.

The submitted qualifications should identify an electrical engineer with professional standing or a qualified electrician who will be responsible for the project.

Professional standing

The term “professional standing” is intended to include legally recognized designations such as Chartered Professional Engineer (Australia), European Engineer (Europe), Chartered Engineer (United Kingdom), or Professional Engineer (United States).

3.13.2. PV-system-specific qualifications

There may be a need to rely on more than general electrical qualifications to reduce the likelihood of a potential PV system fire. Rooftop PV systems present added challenges, especially as they involve direct current (dc) rather than the more traditional alternating current (ac).

Some manufacturers of PV system components provide product-specific training or certifications for components used in PV systems. For example:

- Enphase – Enphase University and certifications - <https://enphase.com/installers/training>
- SolarEdge – Certified installers - <https://www.solaredge.com/us/installers/3p>
- Stäubli International AG – Training and education services for eBOS (electrical balance of system) – <https://www.staubli.com/us/en/electrical-connectors/industries/renewable-energy/installer.html>

Some geographic areas offer additional certifications specific to PV systems. For example:

- Germany - The German Solar Energy Society (DGS)
 - PV Ready certification
- Germany - TÜV Rheinland
 - PV System Construction and Maintenance certification
- United Kingdom – MSC9 (Microgeneration Certification Scheme)
 - MSC-certified installer¹⁰

⁹ MSC, see <https://www.mcscertified.com/why-mcs/#/>

¹⁰ The MSC certification scheme is accredited by UKAS (United Kingdom Accreditation Service). UKAS is accredited by the IAF (International Accreditation Forum) as an accreditation body.

- United States - The North American Board of Certified Energy Practitioners® (NABCEP®)¹¹ certification offerings:
 - The PV Installation Professional Board Certification¹²
 - The PV Design Specialist Board Certification
 - The PV Installer Specialist Board Certification
 - The PV Commissioning & Maintenance Board Certification

The submitted contractor qualifications should identify PV-specific certifications for the person responsible and other staff who will support the project. Such certification information adds to the contractor's evidence of qualification.

3.13.3. Relevant work experience and references

The submitted contractor qualifications should include the following:

- Their selection criteria for picking sub-contractors (if used).
- A list of previous work involving rooftop PV systems.
- References for several of those systems (perhaps at least five).

Review the list of previous work. For example:

- Search the internet for information regarding favorable or unfavorable insights. The search may identify potential issues for further consideration and discussion with the proposed contractor.
- Look for past work experience, including commercial- or industrial-scale rooftop installations, repeat business with customers, and especially with Fortune 500 companies.

The list of references should include contact information for the PV system owner and the building owner if they are not the PV system owner.

Remember, the intent is to understand the PV system owner's experience and the building owner's experience. Speak to all contacts and request their insights, both favorable and unfavorable.

3.13.4. Final selection of qualified persons

Consider the above criterion in selecting the qualified persons responsible for the PV system design, installation, commissioning, and maintenance.

Consider the above criterion in selecting an independent, third-party quality assurance person.

Where the building roof will be leased to the PV system owner, pursue a lease agreement that:

¹¹ NABCEP®, see: <https://www.nabcep.org/certifications/nabcep-board-certifications/>

¹² The NABCEP® certification for PV Installation Professional is accredited by ANAB (ANSI National Accreditation Board). ANAB is accredited by the IAF (International Accreditation Forum) as an accreditation body.

Photovoltaic (PV) systems on buildings
Design, installation, and operation

- Includes the use of an independent, third-party quality assurance person
- Allows the building owner to review and influence the selection of the contractors and quality assurance person

4. Design

As a new PV system is planned, consider the following measures to guide the system design phase. These measures aim to reduce the likelihood of losses due to fire, hail, lightning, seismic activity, or wind.

See Appendix B for a checklist of items to include in the design documents.

See Appendix H Section H.1 for an outline of information to be included in a PV system design document submittal.

4.1. Codes and standards

Have the design documents enumerate the codes and standards that apply to the project.

Have the design documents include a specification to comply with the enumerated codes and standards.

Local codes and standards

Local codes and standards may include provisions for the following recommended PV system features:

- Fire service rooftop access along the roof perimeter and walkways throughout the rooftop area.
- PV system module placement, also, see the Zurich guidance on PV system module placement (section 4.9).
- PV system rapid shutdown (see section 4.6)

4.2. Zurich natural hazards data

Where provided, have the design documents include the Zurich natural hazards data as follows:

- Earthquake – The Zurich identified earthquake hazard level where it is high or very high
- Flood – The Zurich identified flood hazards, including fluvial (river), pluvial (runoff), and storm surge (coastal)
- Hail – The Zurich identified hail hazard level where it is medium, high, or very high
- Lightning - The Zurich identified lightning hazard level where it is high or very high
- Wind - The Zurich recommended design wind speed along with the actual design wind speed for the project

4.3. Wind, seismic, and structural evaluation

4.3.1. PV design documents – Wind and seismic resistance

Have the PV system design documents include details on the PV module securement to resist wind and seismic loads (if exposed to earthquake).

4.3.2. Structural engineer's report - Building structural capacity

Have the project structural engineer prepare a report with load calculations confirming the following:

- The proposed PV system design will resist anticipated loads associated with wind and earthquake (if exposed to earthquake).
- The building structural design, along with any required upgrades, will accommodate the minimum design loads with the proposed PV system included.
- Any assumptions used in their calculations.

Note: Where the structural engineer's report includes assumptions, supplemental reports will be needed with updated calculations based on added information that eliminates the assumptions.

4.3.3. PV array movement tracking

Have the PV system design documents specify exact distances between the corners of the PV arrays and fixed rooftop points (e.g., construction features or rooftop equipment). Have the design documents specify that the installer confirms these distances once the PV system is installed and make any adjustments on the as-built drawings.

In addition, have the PV system design documents require the installer to mark the location of each array corner using a method (e.g., paint) acceptable to the roof cover manufacturer.

The above guidance will help monitor the PV system for movement during future visual inspections.

4.3.4. Structural engineer with professional standing

Verify that the structural engineer's report is prepared by a structural engineer who has professional standing (see section 3.13).

4.4. Selection of PV system components and features

4.4.1. PV system architecture

Select a PV system that uses either microinverters, dc-to-dc converters, or string inverters as discussed below.

Microinverters are considered a Zurich Recognized Technology when listed by a Zurich Recognized Testing Laboratory. They are typically installed at each PV module. Conversion from dc to ac takes place at the module level. Microinverters may reduce the likelihood of fires by limiting rooftop direct current (dc) to the PV modules. PV system cables beyond the PV modules carry alternating current (ac).

Dc-to-dc converters (such as optimizers) are considered a Zurich Recognized Technology when listed by a Zurich Recognized Testing Laboratory. They are typically provided to control one or more PV modules.

Consider applying dc-to-dc converters as follows:

- Use the dc-to-dc controller as part of a PV system automatic shutdown in response the arc or ground fault detection at the inverter.

- Upon automatic shutdown, reduce the voltage within an array to 80 Vdc, but consult with Zurich if the reduced voltage will exceed 125 Vdc.

String inverters are considered a Zurich Recognized Technology when the inverter is listed by a Zurich Recognized Testing Laboratory. They are typically provided to control one PV array.

Consider applying string inverters as follows:

Note: The following was informed by the guidance of several PV rack manufacturers who have developed systems listed by ETL as being compliant with UL 3741, *Standard for Safety for Photovoltaic Hazard Control*.

- As with any PV system, consider the following:
 - Include at least one main ac disconnect switch that will be readily accessible to the public fire service during a fire emergency.
 - Note: The intent is to allow firefighters the ability to activate a rapid shutdown for those PV systems equipped with rapid shutdown. For further discussion on rapid shutdown, see Section 4.6.
 - Keep PV circuit cables of opposite polarity separated by at least 75 mm (3 in.) when they are exposed (not in a conduit, cable tray, or other listed enclosure).
 - Note: The intent is to help minimize the chance of a parallel arc fault between cables of opposite polarity (+ and – cables). For further discussion on parallel arc faults, see Section 2.7.3. It is understood that where cables approach and enter conduits, cable trays, or other enclosures, the cables of opposite polarity may be closer than 75 mm (3 in.).
- In addition, like the arrangement of the ETL-listed systems that are considered compliant with UL 3741, consider the following:
 - Locate the string inverter within the array boundary (within 300 mm (1 ft.) of the array). If a string inverter is receiving dc current from PV modules located in a separate array boundary, provide additional automatic dc disconnects to de-energize cables located outside of the array boundary where the string inverter is located.
 - Secure PV circuit cables routed under a row of PV modules, so they do not extend out beyond the edges of the modules forming the module row.
 - Do not allow PV circuit cables to touch conductive metal such as metal module frames or metal racks. Specifically, secure cables so there is an air gap between the cables and conductive metal such as metal module frames or metal racks.
 - Note: The ETL-listed rack manufacturers typically mention the use of cable ties like the Hellermann Tyton Cable Clip

Ties (model numbers 156-02224, 156-02226, or 156-02230).

- Secure cable ties, but do not overtighten or pinch the cables.
- Secure PV circuit cables within 150 mm (6 in.) of a connector.
- Do not allow cables to sag between clips or ties.
- Note: We anticipate that some degree of reason will need to be applied to this guideline to avoid excessive cable bend radii.
- Enclose PV circuit cables extending beyond a module row in a conduit, cable tray, or other listed enclosure.
- Note: The ETL-listed rack manufacturers typically offer an example of a suitable cable enclosure named RayTray.
- Arrange PV circuit cables to enter and exit conduit, cable tray, or other listed enclosure in a location away from firefighter exposure.
- Where PV circuit cables enter and exit a conduit, cable tray, or other listed enclosure, avoid sharp edges that may damage cable insulation.

4.4.2. Component listing and compatibility

Have the PV system design documents specify that all system components are to be listed for their intended purpose in the PV system by a Zurich Recognized Testing Laboratory.

In addition, have PV system design documents specify that all system components are to be listed explicitly by a Zurich Recognized Testing Laboratory for use together in a PV system. Of particular concern are PV circuit connectors used in PV string circuits that join PV modules to each other and their junction box (combiner box) or inverter. See section 2.8 and section 4.4.3 for further discussion on connector listings and ratings.

Zurich Recognized Testing Laboratories

Zurich Recognized Testing Laboratories are product certification bodies. They are qualified to perform self-accreditation of their product testing. Their services include product conformity certification, publication of a list of certified products, and a follow-up program to monitor the ongoing compliance of certified products.

Zurich Recognized Testing Laboratories are evaluated by qualified third-party accreditation bodies. Acceptable third-party accreditation bodies include members of the International Accreditation Forum, Inc. (see http://www.iaf.nu/articles/IAF_MEMBERS_SIGNATORIES/4)

4.4.3. PV connectors

Apply this guidance to all connectors, including Apply the guidance provided in section 2.8 to all connectors, including:

- Connectors provided with PV modules.
- Connectors provided with microinverters and dc-to-dc converters (including optimizers).
- Connectors that are field-fabricated.

The guidance in section 2.8 addresses the following topics:

- Connector listing
- Connector mating
- Connector mismatch
- Connector protection in the field
- Connectors and field-fabrication

4.4.4. PV modules

Storage and handling - Have design documents include guidance on the storage and handling of PV modules awaiting installation, including:

- Storing PV modules awaiting installation in a dry location, such as indoors or in trailers.
- Where the PV modules are stored at a remote location, provide just-in-time delivery of PV modules to the job site for installation that day.
- Avoid having PV modules outdoors with open, unmated connectors when it is raining or surfaces are wet.
- In hurricane-prone regions, having a plan to complete all wind resisting features for installed PV components once a hurricane or tropical storm watch is issued. Also, having the plan includes moving all unsecured material from the building roof to an indoor location.
- As PV modules are unpackaged, they should be installed and connectors mated with a minimum delay to reduce the chance of connector contamination by dust, debris, moisture, or water.

Unprotected connectors may be exposed to insects, dirt, or rainwater until the connectors are joined, forming watertight connections. Contaminated connectors may experience corrosion, leading to arc faults and fires.

If there is any doubt PV module connectors will be stored and handled as discussed above, have the PV manufacturer ship PV modules with each lead fitted with a protective cap.



PV wire connectors - left photo disconnected and right photo connected. (Source: ZRS)

Hail resistance - Where PV modules are being installed at a location in a hail zone rated by Zurich as medium, high, or very high, have PV system design documents specify PV modules that are certified to the highest hail testing requirements of either IEC 61730 or UL 61730.

Very high hail zones

Realize that locations in medium, high, or very high rated hail zones may be exposed to hailstorms exceeding the most challenging hail test requirements available in either IEC 61730 or UL 61730. Such areas may be found in areas such as north central Argentina, the east coast of Australia, and in the central and southeast United States. The potential for significant hail damage should be expected in such areas.

4.5. Automatic shutdown for faults

Have PV system design documents specify that the system be arranged to automatically disconnect PV modules upon detecting an arc fault, ground fault, or inverter fault.

4.6. Rapid shutdown switch

Rapid shutdown is an NFPA 70, National Electrical Code (NEC), concept that applies to PV systems on buildings. The requirement was added to NFPA 70 (NEC) for firefighter safety.

While “rapid shutdown” is an NFPA 70 (NEC) term, Zurich recommends that the PV system design documents specify that systems be arranged for manual PV system rapid shutdown via a switch accessible to the responding fire service.

The rapid shutdown function should be made part of the pre-fire plan.

Rapid shutdown additional insights

The rapid shutdown function involves a manual switch accessible to firefighters.

NFPA 70-2014 introduced the first version of rapid shutdown, and it involved reducing voltage outside the PV array to less than 30 volts (ac and dc).

NFPA 70-2017, expanded rapid shutdown to include an approach referred to as “module-level” rapid shutdown. Within 30 seconds of initiating rapid shutdown:

- The voltage within 0.3 m (1 ft.) of an array, and within the array, is not to exceed 80 volts (ac or dc)
- The voltage over 0.3 m (1 ft.) from an array is not to exceed 30 volts (ac or dc)

Examples of module-level rapid shutdown arrangements include:

- Microinverters – When the PV system main ac disconnect switch is opened, the microinverters will stop all ac output current. Rapid shutdown is achieved when the PV module connected to a microinverter does not exceed 80 Vdc.
- Dc-to-dc converters (optimizers) – When the PV system main ac disconnect switch is opened, the inverter will signal the dc-to-dc converters (optimizers) to reduce dc output to around 1 Vdc with a total string output voltage not exceeding 30 Vdc. Rapid shutdown is achieved when the PV modules attached to each dc-to-dc converter (optimizer) do not exceed 80V.

NFPA 70-2020, added the concept of PV Hazard Control System.

- PV hazard control system (PVHCS) –The PVHCS is a listed system. The NFPA 70-2020 points to UL 3741, **Standard for Safety for Photovoltaic Hazard Control**; as a test protocol that testing laboratories may apply to list PV systems as complying with the PVHCS as an option to the prescriptive NFPA 70-2017 requirement to reduce voltage within an array to less than 80 Vdc when the rapid shutdown switch is operated. The intent of the UL 3741 listed system is to incorporate added features that help protect firefighters from energized PV system components.

4.7. PV system fault monitoring

Have the PV system design documents include a list of faults that will cause the automatic shutdown of the PV system. These faults should consist of at least the following:

- Arc fault detection
- Ground fault detection
- Any inverter fault

PV system fault monitoring

As discussed in Chapter 6 (Operation), once the PV system is in operation, remote monitoring is recommended. During the design phase, specify equipment that will support remote monitoring.

4.8. PV system electrical requirement

Have the PV system design documents include specifications for:

- Surge protection features
- Bonding and grounding of all conductive, non-current-carrying system components
- Wiring and cables
- Conduit (raceway) and cable trays
- Conduit thermal expansion devices, including the make, model, and locations

4.9. PV module placement

Have PV system design documents verify the location of PV modules and PV arrays with respect to roof penetrations, firewalls, roof edges, roof elevation changes, adjacent PV arrays (PV array separation distance), fire service walkways, and roof drainage as discussed in the following subsections.

4.9.1. Distance from PV modules to roof penetrations

PV modules should not be located above or too close to roof penetrations.

Roof penetrations may allow a PV fire to spread into a building. The recommended distance between PV modules and roof penetrations may help avoid such fire spread.

Roof penetration may provide a pathway for rainwater leakage into a building. The recommended distance between PV modules and roof penetrations may provide sufficient access to roof penetrations for periodic inspection and maintenance.

Remember, fill gaps around each roof penetration using a noncombustible material such as mineral wool. See section 3.8.2 for further guidance.

[Expansion joints and seismic joints](#) – Maintain at least 600 mm (2 ft.) between PV modules and expansion or seismic joints.

Roof designs may include expansion joints to accommodate thermal expansion and contraction. In earthquake-prone regions, the joints may be aligned with building seismic separations.

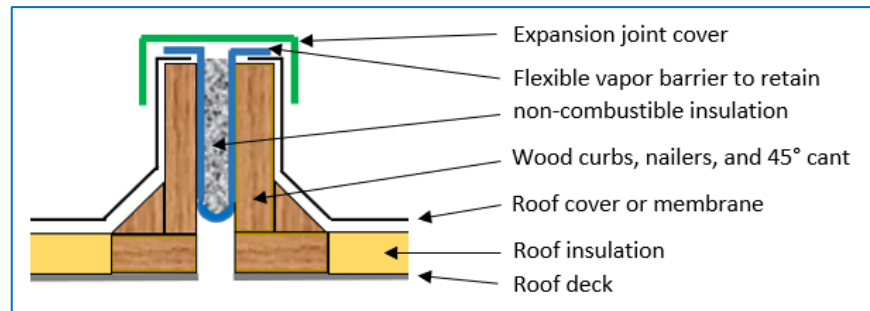

Schematic example of a low-slope roof expansion joint. (Source: ZRS)

Roof drains, vent pipes, and similar small penetrations - Maintain at least 600 mm (2 ft.) between PV modules and small penetrations such as roof drains, vent pipes, and electrical conduits. Using stainless steel or cast-iron drains, pipes, and conduits may be favorable.



An example of a roof drain on a low-slope roof adjacent to PV modules. (Source: ZRS)

Smoke & heat vents, HVAC equipment, and similar large penetrations - Maintain at least 1.2 m (4 ft.) between PV modules and larger penetrations such as smoke & heat vents, roof hatches, HVAC equipment, and skylights.

Arrange smoke and heat vents so their operation is not likely to cause damage to a PV system.

During rooftop equipment service work (e.g., for HVAC equipment), consider increasing the 1.2 m (4 ft.) distance based on equipment size and the needed workspace. Increased spacing may also reduce the shading of PV modules from rooftop equipment.



An example of a large piece of rooftop equipment adjacent to PV modules. (Source: ZRS)

4.9.2. Distance of PV systems from firewalls

All PV system components, including PV modules and PV cables, should be kept away from firewalls.

Keep PV system components at least 2.5 m (8 ft.) from fire-rated walls. Where the fire-rated wall parapet extends at least 0.5 m (18 in.) above the highest point of the PV modules, the separation distance may be reduced to 1.2 m (4 ft.).

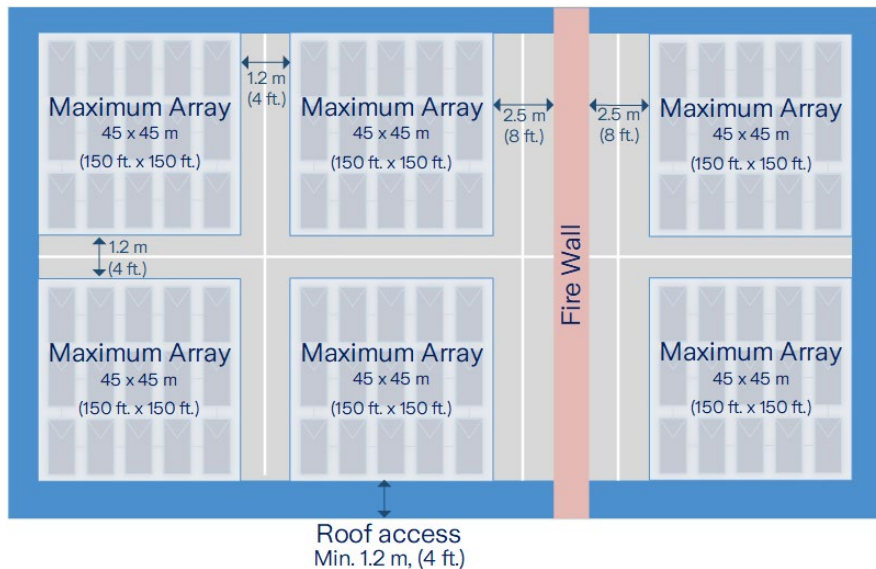

Rooftop diagram depicting the separation of a firewall from PV arrays. It also shows the PV array roof edge setback, maximum array size, and minimum array spacing. (Source: ZRS)

4.9.3. Distance of PV modules from roof edges

Keep all PV system modules at least 1.2 m (4 ft.) from roof edges. Increase this distance as required by local codes.

The PV module roof edge setback intends to provide firefighters with an initial area of access to a rooftop.



An example of a PV system roof edge setback. (Source: ZRS)

4.9.4. Distance of PV modules from roof elevation changes

Keep all PV system modules at least 5 m (15 ft.) from roof elevation changes.

Where the wall at the elevation change is fire-resistant and does not have unprotected openings, this distance may be reduced to 1.2 m (4 ft.).



An example of a separation distance between a PV system and a roof elevation change. (Source: ZRS)

4.9.5. Distance between PV arrays and PV array size

Keep PV arrays separated by walkways at least 1.2 m (4 ft.) wide and limit arrays so they are not larger than 45 m x 45 m (150 ft. x 150 ft.).



Examples of a PV array (red box) and PV system walkways (red arrows) (Source: ZRS)

4.9.6. Fire service access and support features

Provide additional walkways for firefighting purposes as required by local codes and standards.

Consult with the fire service to develop a fire service diagram providing information including the locations of:

- Fire service vehicle access points
- Roof access (stairs, perimeter PV module setbacks)
- Firefighting water supplies
- Firefighting hose connections or riser (standpipes)
- PV modules and walkways
- Normally energized wires and components
- Disconnect switches
- Rapid shutdown switches

4.9.7. Roof drainage and drains

Provide the PV system designer with a roof plan showing the arrangement of the roof drainage and the location of roof drains (see section 3.9).

Have the PV system design documents show the roof drainage and roof drains and have the design documents address the placement of PV system components so they avoid interference with the roof drainage and roof drains.

4.10. Protection systems

Protection systems include the following:

- For any PV system:
 - Rooftop fire detection connected to a fire alarm control unit that is monitored at a constantly attended location where fire alarm signals will be promptly reported to the fire service
 - PV system surge protection
- For selected PV systems:
 - Lightning protection for the building and PV system
 - Rooftop fixed fire protection

4.10.1. Rooftop fire detection

Provide a fire detection system for each rooftop PV system. Options include:

- Line-type heat detection
- Flame detection

Consult a qualified fire detection system designer to help identify the most cost-effective option.

See Appendix H Section H.3 for an outline of information to be included in an automatic fire detection plan submittal.

Fire detection device – Design and install the rooftop fire detection system in accordance with a Zurich Recognized Protection Principle such as BS EN 54 (*Fire detection and fire alarm systems*) or NFPA 72 (*National Fire Alarm Code*).

Future fire alarm technology

Zurich looks forward to reviewing potential future PV system technology that may include rooftop PV system fire detection.

For example, consider a microinverter or optimizer developed to include a fire detection capability that is listed by a Zurich Recognized Testing Laboratory for the intended purpose of detecting a rooftop PV system fire and to be applied in accordance with a Zurich Recognized Protection Principle such as BS EN 54 (*Fire detection and fire alarm systems*) or NFPA 72 (*National Fire Alarm code*).

Line-type heat detection – Line-type heat detectors include metallic wire and fiber optic sensor cables and other available types.

The metallic wire provides a fixed-temperature fire alarm signal. The fiber optic cable provides continuous temperature monitoring along the entire cable.

The wire or cable is extended along each PV module at the highest edge. The wire or cable may also be routed along cable trays.

While line-type heat detectors will be designed and installed following local codes and standards, there will likely be additional guidance from the testing laboratory that lists the product and the manufacturer who makes the product.



Example of a line-type heat detector (Source: The Protectowire Company, Inc. with permission)

Flame detection – Engage a qualified fire detection system designer to recommend a flame detector that will sense the expected radiant-emission wavelengths associated with a rooftop PV system fire and reduce the likelihood of unwanted alarms. An example is the triple IR (infrared) flame detector.

There are no prescriptive installation guidelines for flame detectors. The designer will determine the number and placement of the flame detectors monitoring the overall PV system. The number and location of flame detectors will be based on the characteristics of the selected flame detector.



Example of a triple IR flame detector (Source: Fike Corporation with permission)

4.10.2. PV system surge protection

Provide surge protection for PV systems following the PV system manufacturer's guidelines, the PV system designer's guidance, and Zurich Recognized Protection Principles such as IEC 62305, NFPA 780, or VdS 2031 (see section 3.7.4).

Power surges have several causes, including lightning discharges. Surge protection is intended to redirect power surges to the ground rather than allowing them to pass through sensitive electronics such as inverters, communication systems, and interconnecting meters. Specifically listed dc PV surge protection devices are available to protect combiner boxes, disconnects, and inverter inputs.

4.10.3. Lightning protection

Where recommended during the pre-design phase, provide a lightning protection system in accordance with a Zurich Recognized Protection Principle such as IEC 62305, NFPA 780, or VdS 2031 (see section 3.7.4).

See Appendix H Section H.5 for an outline of information to be included in a lightning protection system plan submittal.

4.10.4. Rooftop fixed fire protection

Provide a rooftop fixed fire protection system where recommended during the pre-design phase. Consult Zurich for further guidance (see section 3.8).

See Appendix H Section H.4 for an outline of information to be included in a fixed fire protection plan submittal.

4.11. Design documents

Develop PV system design documents that include:

- Design information outlined in the Appendix B checklist
- Installation information outlined in the Appendix C checklist
- Commissioning information outlined in the Appendix D checklist

4.12. Plan submittals to Zurich

Before starting work on the PV system, submit the design documents to Zurich for plan review and comment. See Appendix H for a list of information to be submitted.

Resolve all plan review comments before installation begins.

5. Installation

As a new PV system is installed and commissioned, consider the following measures to guide the installation phase. These measures aim to reduce the likelihood of losses due to collapse, fire, hail, lightning, seismic activity, or wind.

See Appendix C for a checklist of items to consider during the PV system installation.

See Appendix D for a checklist of items to consider during the PV system commissioning.

5.1. QA person qualifications and duties

Hire a qualified, independent, third-party quality assurance person to monitor the PV system installation and commissioning. This person is to verify that the PV system is installed in accordance with the design documents.

5.1.1. Qualified person

See 3.13 for a discussion on qualified persons.

5.1.2. Duties

The duties of the third-party quality assurance person should include the following:

- **Observing**
 - Observing the PV system installation and commissioning, specifically including the “golden row” (see section 2.9.2).
- **Confirming**
 - Confirming the PV system is installed and commissioned in accordance with the design documents.
- **Notifying**
 - Advising the installer, PV system owner, and building owner of any identified installation or commissioning deviations from the design documents.
- **Verifying**
 - Verifying any noted installation or commissioning deviations have been resolved. Resolution may involve rework in accordance with the design documents or allowing deviation considered to be acceptable or equivalent to the original design documents.
- **Documenting**
 - Providing documentation in a written or digital format to the installer, PV system owner, and building owner as follows:
 - Deviation reports – Documentation of deviations from the design documents involving the PV system installation or commissioning.

- Resolution reports – Documentation of the resolution to any noted installation or commissioning deviation.
- Final report - Once the installer reports that the installation and commissioning are complete, provide a report documenting any unresolved deviations or documenting that the project has been completed in accordance with the design documents along with any accepted deviations.

5.2. Installer qualifications and duties

Hire a qualified installer to install and commission the PV system.

5.2.1. Qualified person

See section 3.13 for a discussion on qualified persons.

Workers performing general tasks that do not involve electrical connections may have minimal qualifications. A qualified person should supervise them to verify that they are handling, placing, and securing PV system components in accordance with the design documents.

Workers handling electrical connections should be qualified electricians with additional training and experience installing PV systems. In particular, they should be trained and qualified to field assemble crimped and plug connectors.

Those responsible for the overall PV system installation and commissioning should possess the highest qualifications, as discussed in section 3.11.

5.2.2. Duties

The duties of the installer should include:

- **Managing**
 - Maintaining a qualified installer representative on-site to manage and supervise all PV system installation and commissioning, specifically including the “golden row” (see section 2.9.2).
- **Confirming**
 - Confirm that the PV system is installed and commissioned in accordance with the design documents.
- **Notifying**
 - Advise the third-party quality assurance person, the PV system owner, and the building owner of any necessary deviations due to job site conditions.
 - Advise the building owner of any roof damage during installation so the damage may be repaired promptly.
- **Verifying**
 - Verify deviations from the design documents are resolved (resolution may involve rework in accordance with the design documents or confirming the deviation is acceptable to or considered equivalent by the third-party quality assurance person).

- Verify that any commissioning issues are resolved within a timeframe agreed upon with the PV system owner, building owner, and the third-party quality assurance person.
- **Documenting** – Provide documentation in a written or digital format to the third-party quality assurance persons, PV system owner, and building owner as follows:
 - Final report - Once the installation and commissioning are reported as being complete, provide a report documenting the following:
 - For any noted installation deviations, document the deviation and its resolution.
 - For any noted commissioning deviations, document the deviation and its resolution.
 - Confirm that the project has been completed in accordance with the design documents, along with any accepted deviations.
 - As-built design documents - Upon completion, submit as-built design documents to the third-party quality assurance person, the PV system owner, and the building owner. Marked the documents to show any changes from the original design documents.
 - Commissioning report - Provide a completed commissioning report.

5.3. Hurricane-prone regions

In hurricane-prone regions, have a plan to complete all wind-resisting features for installed PV components once a hurricane or tropical storm watch is issued.

Also, have the plan include the moving of all unsecured material from the building roof to an indoor location.

What should be done if an existing PV system has not been commissioned or completely commissioned?

If there is no documentation of a successful PV system commissioning or if the commissioning is incomplete, consider the following actions:

- Performing an inspection of the system (see Chapter 5 and Appendix C)
- Conducting a re-commissioning of the system (see Chapter 5 and Appendix D)
- Verify the system complies with applicable local codes and the original design drawings
- Where deviations or issues are noted, retrofit, repair, or decommission the system as needed

6. Operation

The operation phase offers an opportunity to minimize the likelihood of a loss involving the PV system. Consider the measures outlined in this chapter.

6.1. Terminology

The following terms are used in this chapter and its related appendices.

Monitoring – A continuous supervision of a system, often by electronic means, to detect changes that warrant an action.

Inspection – An activity involving the visual observation of a system or its components to evaluate its apparent physical condition, serviceability, and need for testing or maintenance.

Testing – A functional activity involving the operation of a system or its components to confirm its ability to perform as intended.

Maintenance – A service activity such as cleaning, adjustment, lubrication, renewal, repair, overhaul, or replacement of a system component to maintain its performance and serviceability.

6.2. PV system monitoring

Consider establishing a process for monitoring the PV system.

6.2.1. Monitoring system

The monitoring system should provide a means to extract PV system data related to faults or trouble conditions and transmit that data to a constantly attended monitoring station where appropriate and timely action may be initiated. As a minimum, monitor the following faults:

- Arc fault
- Ground fault
- Any inverter fault

6.2.2. Cause and Effect List

Prepare a Cause and Effect list summarizing the monitored fault, trouble conditions, and intended actions. The list should include the following:

- **Conditions** – A list of monitored fault or trouble conditions.
- **Priority** – A relative priority level for each fault or trouble condition.
- Note: High-priority conditions should warrant immediate maintenance action or immediate notification of the public fire service.
- **Notification** – Establish the actions to be taken by the persons at the monitoring station for each monitored condition.
- Note – The actions should include who to notify and how fast. The timing of the notification action should align with the assigned priority level of the fault or trouble condition.

- **Response** – Establish the actions to be taken by the person notified and responding to the fault or trouble condition.
- Note - The timing of the response action should be based on the assigned priority of the monitored condition.
 - Within 24 hours of any inverter fault - Have a technician at the location for troubleshooting, and do not restore the PV system operation until the fault has been corrected
 - Within 72 hours of any arc and ground fault detection – Have a technician at the location for troubleshooting, and do not restore the PV system operation until the fault has been corrected

6.2.3. Operational log

Maintain an operational log to document the monitoring system activity.

The log should capture each signal received and the action taken. For example, for arc and ground faults, log the date and time of the fault and the action taken in response to the fault.

The log should be accessible to both the PV system owner and the building owner if they are not the same.

6.2.4. Zurich review and comment

A description of the monitoring system and a copy of the Cause and Effect list should be submitted to Zurich for review and comment.

6.3. Contractor control program - General

Develop, document, and implement a general contractor control program. The program is to include initial training (first visit to the location) and annual refresher training for each member of the contractor's staff. The training should include:

- Procedures such as escort requirements, no-smoking areas, and fire reporting procedures
- Hazards such as areas to avoid due to ignitable liquids, combustible dust, and flammable gases
- Work permitting procedures such as hot work permits or fire system impairment permits

6.4. Contractor control program – Roof access

Develop, document, and implement a program to control roof access.

Have staff escort persons to the roof (such as HVAC contractors) who are not qualified to work on PV systems.

The intent is to monitor those on the roof to help reduce the likelihood of damage to the photovoltaic system and to promptly detect and report any damage that does occur so the PV system contractor may promptly address it.

Contractors working on a roof for purposes other than the PV system may not be aware of the fire hazard that may develop if the PV system is damaged. Damage could arise from actions such as:

- Sitting on PV modules, cable trays, or other system components
- Putting or dropping tools, equipment, or other items onto PV modules or other system components
- Leaving loose sheet metal panels that may blow across the roof, impacting the PV system
- Leaving waste materials on the roof that could obstruct roof drains

6.5. Rooftop self-inspections

Expand the location self-inspection program to include rooftop self-inspections to verify that the rooftop is kept clear of vegetation and debris, especially any accumulations under or around PV systems.

Initially, conduct rooftop inspections every month.

Self-inspections are optional for months where the PV maintenance contractor has performed a post-storm, post-earthquake, or annual inspection.

Adjust the self-inspection frequency based on your experience and judgment. In other words, if your roof is not exposed to accumulations of vegetation or debris, the frequency may be extended.

At a minimum, perform a self-inspection at least two times a year at the beginning of the spring and fall seasons.

Remember, any time staff goes to the roof, it offers an opportunity to observe the condition of the rooftop and PV system. Train staff on the rooftop self-inspection objectives so they may report any issues they observe.

See Appendix E for a checklist of items to consider including in the rooftop self-inspections.

In addition to checks related to vegetation and debris, the monthly self-inspection also includes a visual review of the PV system for any signs of:

- Debris or dirt on PV modules, including bird waste
- Equipment movement, including movement due to high winds or seismic activity
- Physical damage, including broken module glass, lightning strike, or rodent damage to visible cable insulations
- Duress, including aging, deterioration, discoloration, or corrosion

Any noted issues should be documented, reported, and scheduled for prompt corrective action (or further review) by the appropriate qualified person.

6.6. PV maintenance contractor

Consider hiring a qualified contractor to provide inspections, testing, and maintenance.

6.6.1. Qualified person

Select a PV maintenance contractor who is qualified to maintain the PV system.

See section 3.13 for a discussion on qualified persons.

6.6.1. System as-built design documents

Provide the PV maintenance contractor with a copy of (or access to) all system as-built design documentation.

6.6.2. Inspections

Have the PV maintenance contractor conduct inspections of the installed PV system:

- On at least an annual basis
- After any severe storm event (such as flood, hail, lightning, sand, or wind)

Examples of severe storm events

- Flood – Flood waters that rise to elevations that inundate any portion of the PV system (typically the ground-level equipment).
- Hail – Any hail event with reports of hailstones larger than 2.5 cm (1 in.) in diameter.
- Lightning – Any case where there is a known lightning strike to the building.
- Sand – Any sandstorm event that affects the building (these could cause damage to the PV system or leave sand on the PV modules).
- Wind – Any wind event more than 65 kph (40 mph) and a self-inspection indicate PV modules have moved relative to their marking.

- After a significant earthquake event

Examples of a significant earthquake event

Any earthquake event exceeding a Modified Mercalli intensity of VI or higher (or a Richter Scale magnitude 5 or higher) and a self-inspection indicate PV modules have moved relative to their marking.

- After notification of an issue identified by the building owner

See Appendix F for a checklist of items to consider including in the rooftop PV system inspections conducted by the PV maintenance contractor.

At least annually review the PV component for product recalls.

6.6.3. Testing and maintenance

Have the PV maintenance contractor conduct testing and maintenance as required by the PV system designer and PV system component manufacturers or based upon observed needs.

See Appendix G for a checklist of testing and maintenance activities to conduct as needed.

For annual testing, include thermal imaging. See section 6.7.

6.7. Annual infrared testing

On an annual basis, conduct infrared (IR) testing. All IR testing should be done when the system is fully operational under steady-state conditions. See Appendix G, where the checklist for testing and maintenance addresses infrared testing.

6.7.1. Electrical connections IR testing

Use electrical IR testing to evaluate electrical components and wiring connections within electrical enclosures to identify loose electrical connections or failing components.

When infrared testing identifies deficiencies in connections, take corrective action promptly.

6.7.2. PV array IR testing

Use PV array IR testing to evaluate the PV modules throughout each PV array to identify temperature anomalies such as hot module junction boxes or hot cells within a module. Large rooftop systems should consider using drones to provide aerial IR imaging to find PV module and equipment failures.

Where infrared testing identifies hot spots or anomalies in equipment, further investigate the affected modules to determine if corrective action is needed.

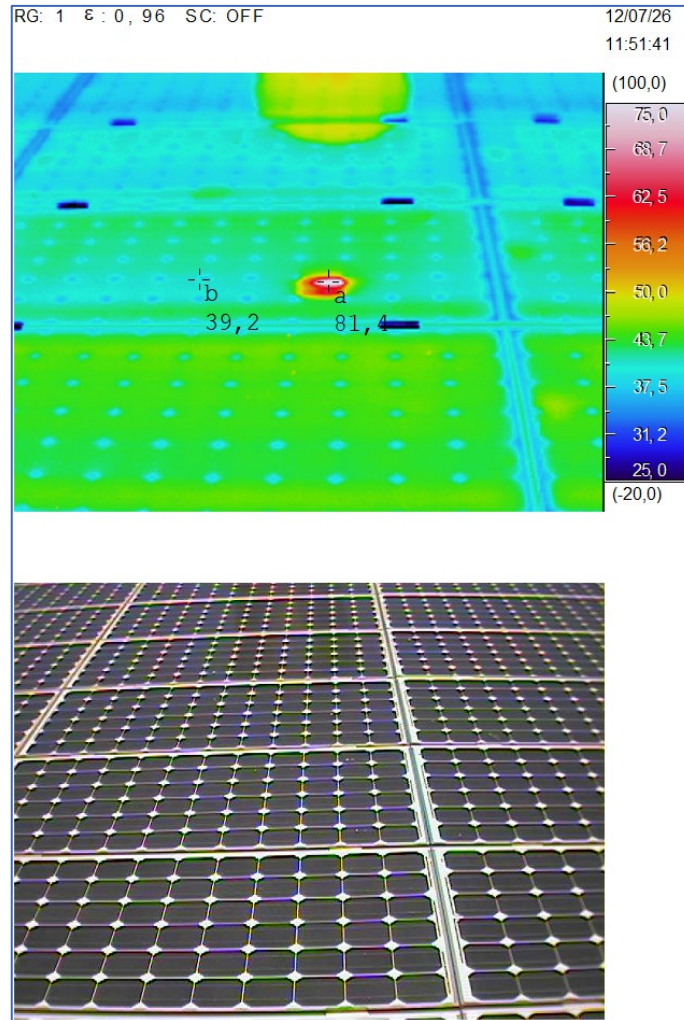

Example of PV array thermal imaging showing a relatively hotter cell in a PV module. (Source: With permission from Lutz Erbe)

6.8. Change management

Develop, document, and implement a program to manage changes to the rooftop PV system.

6.8.1. PV system component change

Use the change management program to evaluate any PV system component change (e.g., changes related to maintenance or repair) that is not a direct replacement with the same make and model of the component. The objective is to verify that the replacement component will be listed for use in PV systems and listed as being compatible with the existing PV system components.

6.8.2. PV system decommissioning

The change management program should evaluate plans to decommission the rooftop PV system. Remember that the rooftop PV modules will continue to generate power whenever they are exposed to light. PV system decommissioning should include plans to remove the PV system.

Once a PV system has been removed, verify that the roof system has been left in a serviceable condition or make repairs as needed.

6.8.3. Change review by a qualified person

The change management program should include a review of changes by a qualified person, such as the original designer or third-party quality assurance person monitoring the installation.

6.8.4. Change review by Zurich

The change management program should include submitting plans to Zurich for review and comment.

6.9. Other systems - Inspection, testing, and maintenance

Other protective systems, such as fire detection, fire protection, and lightning protection, will need their own inspection, testing, and maintenance procedures.

For fire detection and protection systems, see the Zurich white paper Inspection, testing, and maintenance (ITM) - Fixed fire protection and detection.

For lightning protection systems, consult a Zurich Recognized Protection Principle such as IEC 62305, NFPA 780, or VdS 2031 (see section 3.74).

7. Emergency response

PV systems may experience fire emergencies or faults that may lead to fire emergencies. So, consider developing response plans to address both.

7.1. Fire emergency response

7.1.1. General steps

The management of a fire emergency involves the following steps:

- **Detection** – Realizing a fire has occurred
- **Notification** – Summoning the fire service
- **Fire service response** – Fire extinguishment
- **PV system contractor response** – Electrical hazard control
- **Recovery** – The actions taken to reinstate normal operations

Detection - Responding to a rooftop PV system fire begins with fire detection. The objective is to detect the fire as soon as possible so it has the least time to spread before the fire service responds and extinguishes it.

As a PV fire spreads, the fire damage to the PV system and roof increases, the amount of firefighting water used increases, and the amount of damage inside the building below increases. So, the objective is early fire detection.

Zurich recommends an automatic rooftop fire detection system to help provide early fire detection. Otherwise, detection may be delayed until a person detects and reports the fire.

Notification – The next step is notifying the fire service once a fire is detected.

Zurich recommends monitoring the rooftop automatic fire detection system at a constantly attended location where alarms will be promptly communicated to the fire service.

But include a backup. Have your emergency procedure include a manual notification to the fire service (e.g., a telephone call).

Fire service response – Once the fire service has been notified, the objective is for them to respond and extinguish the fire. As a PV system fire will involve an electric power generating system that cannot be completely de-energized, the fire extinguishment efforts may be challenging.

Remember, actions taken by the fire service during an emergency are most effective when planned in advance. For further discussion on pre-fire planning, see section 7.1.2 below.

PV system contractor response – Once a rooftop PV fire has been extinguished, the emergency has not ended. After all, the rooftop PV system is now damaged and could cause another fire at any time. This has occurred in several fires that damaged PV arrays that were not electrically secured.

Have your emergency procedure include notification of your PV system contractor so they may respond without delay. The objective is to have

them assist the fire service during the extinguishment phase and then take further steps after extinguishment to help reduce the chance of another fire.

Recovery – The recovery phase may include several actions, such as:

- Removing damaged PV system components
- Removing additional PV system components to allow roof repairs
- Repairing the roof
- Reinstating the PV system

As the rooftop recovery is underway, remember that there will likely be additional recovery actions taking place inside the building below.

When reinstating the PV system, consider the following:

- Making repairs in accordance with the original design documents. If there will be changes:
 - Following the change management procedure discussed in section 6.8 (PV system component change)
 - Update the as-built PV system design documents to reflect all changes
- Re-commissioning the entire PV system to establish a new system baseline

Consider including a PV system fire as a scenario considered in any business continuity plan developed for the location.

7.1.2. Pre-fire planning

Invite the fire service and your PV system contractor to your location to help the fire service gather data to develop a written pre-fire plan. The planning visit should allow them to:

- Learn about the PV system hazards
 - Maximum system operating voltage
 - Rapid shutdown capabilities and voltage limitations
- Become familiar with PV system signage
- Become familiar with the PV systems arrangement, including the location of:
 - PV system rapid shutdown switches
 - PV system disconnect switches
 - Fire service rooftop access points and walkways
- Develop an emergency response plan for fires involving:
 - PV system
 - The building under the PV system

On an annual basis, consider inviting the fire service and your PV system contractor to your location so the fire service may review their pre-fire plan,

practice the operation of switches, and update their plan as needed to document any changes (e.g., building additions or other new rooftop equipment).

7.2. Fault emergency response

Section 6.2.2 recommends preparing a Cause and Effect list summarizing the fault and trouble conditions monitored by the PV system. The list would include each fault or condition's priority and needed response.

The fault emergency response procedure should target the faults that could lead to a fire. Examples may include arc faults and ground faults.

The fault emergency response procedure should be initiated by the person located at the constantly attended PV system monitoring station (see section 6.2). The response action should be performed by qualified staff of the PV maintenance contractor. The PV system's operational log should document the fault signal received and the response actions taken.

8. Summary

There are numerous benefits to installing PV systems on roofs, including the ability to generate clean energy and save costs. However, there are also risks associated with this technology that should be considered to avoid potential losses and damage.

Consider the guidance offered in this document to help reduce the chance of a loss involving a rooftop PV system as well as reducing the severity of any loss that may occur.

9. References

9.1. Zurich

Risktopic. Zurich Recognized Technologies for Property risks. Zurich, Switzerland. 2019.

9.2. Fire Protection Research Foundation

Grant, Casey C. Fire Fighter Safety and Emergency Response for Solar Power Systems, Final Report. Quincy, MA: Fire Protection Research Foundation, May 2010. Web. Web site accessed 20230712.

https://nfpa.access.preservica.com/uncategorized/IO_d9d334df-794d-44e2-b8d3-56baf44ea08f/

Wills, Rosalie, James Milke, Sara Royle and Kristin Steranka. Commercial Roof-Mounted Photovoltaic System Installation Best Practices Review and All Hazard Assessment. Quincy, MA: Fire Protection Research Foundation, 2014. Web. Web accessed 20230712. <https://www.nfpa.org/-/media/Files/News-and-Research/Fire-statistics-and-reports/Building-and-life-safety/RFCCommercialRoofMountedPhotovoltaicSystemInstallation.ashx>

9.3. International Energy Agency

IEA Photovoltaic Power Systems Programme: "Quantification of Technical Risks in PV Power Systems" (2021). Web. Web accessed 20230511.

https://iea-pvps.org/wp-content/uploads/2021/11/Report-IEA%E2%80%93PVPS-T13-23_2021-Quantification-of-Technical-Risks-in-PV-Power-Systems_final.pdf

IEA Photovoltaic Power Systems Programme Task 13: "Review on IR and EL Imaging for PV Field Applications" (2020). Web. Web accessed 20230511.

https://iea-pvps.org/wp-content/uploads/2020/01/Review_on_IR_and_EL_Imaging_for_PV_Field_Applications_by_Task_13.pdf

9.4. NFPA

NFPA 1. Fire Code. Quincy, MA; NFPA, 2021. Online.

NFPA 70. National Electrical Code®. Quincy, MA; NFPA, 2023. Online.

NFPA 497. Recommended Practice for the Classification of Flammable Liquids, Gases, or Vapors and of Hazardous (Classified) Locations for Electrical Installations in Chemical Process Areas. Quincy, MA; NFPA, 2024. Online.

NFPA 780. Standard for the Installation of Lightning Protection Systems. Quincy, MA; NFPA, 2023. Online.

9.5. TÜV Rheinland

"Technical Risks in Photovoltaic Projects, Report on Technical Risks in PV Project Development and PV Plant Operation." Cologne, Germany: TÜV Rheinland Energy GmbH, 2017. Web. Web accessed 20230717.

<https://www.tuv.com/content-media-files/master->

[content/services/products/p06-solar/solar-downloadpage/solar-bankability_d1.1_d2.1_technical-risks-in-pv-projects.pdf](#)

“Assessing Fire Risks in Photovoltaic Systems and Developing Safety Concepts for Risk Minimization”, Cologne, Germany: TÜV Rheinland Energy GmbH, 2017. Web. Web accessed 20230923.

<https://www.google.com/url?sa=t&rct=j&q=&esrc=s&source=web&cd=&cad=rja&uact=8&ved=2ahUKewiU77Htk8GBAxWBk2oFHWliDdAQFnoECBAQAQ&url=https%3A%2F%2Fwww.energy.gov%2Ffeed%2Fsolar%2Farticles%2Fassessing-fire-risks-photovoltaic-systems-and-developing-safety-concepts-risk&usq=AOvVaw2xAXY80co1jHlfADXuDsCy&opi=89978449>

9.6. VdS Schadenverhütung GmbH

VdS 3145:2017-11. "Photovoltaic systems", VdS Schadenverhütung GmbH: 2017. PDF.

VdS 6023:2023-02. "Photovoltaic systems on roofs with combustible building materials." VdS Schadenverhütung GmbH. 2023. PDF.

VdS 2234:2012-07. "Firewalls and complex partition walls." VdS Schadenverhütung GmbH. 2012. PDF.

VdS 2031. "Lightning and surge protection in electrical systems." VdS Schadenverhütung GmbH. 2012. PDF.

9.7. Other

Wirth, Harry. "Current facts about photovoltaics in Germany." Freiburg, Germany: Fraunhofer Institute for Solar Energy Systems. 2023. Web. Website accessed 20230717.

<https://www.ise.fraunhofer.de/content/dam/ise/de/documents/publications/studies/aktuelle-fakten-zur-photovoltaik-in-deutschland.pdf>

SolarEdge Commercial Power Optimizers. SolarEdge. Web. Web site accessed 20230712.

<https://www.solaredge.com/us/products/commercial/power-optimizers>

“Commercial Solar.” Enphase. Web. Web site accessed 20230712.

<https://enphase.com/installers/commercial>

C.W. Griffin and R. L. Frickless. Manual of Low-Slope Roof Systems-Fourth Edition. McGraw-Hill, 2006. Print.

“Taking ownership of your new solar project: is that in-service date realistic?”, Oslo, Norway, DNV. Web. Web site accessed 20230923.

<https://www.dnv.com/article/taking-ownership-of-your-new-solar-project-is-that-in-service-date-realistic--200188#>

Lavrova, Olga, et. al. PV Systems Reliability: Final Technical Report. Albuquerque, NM, USA: Sandia National Laboratories. 2015. Web. Web site accessed 20231005.

https://www.google.com/url?sa=t&rct=j&q=&esrc=s&source=web&cd=&cad=rja&uact=8&ved=2ahUKewjOr6v54N-BAxVolGoFHWHYDaUQFnoECBgQAQ&url=https%3A%2F%2Fwww.osti.gov%2Fservlets%2Fpurl%2F1342493&usq=AOvVaw1zn-ZzzkTVvxoKc_-Qel1x&opi=89978449

10. Selected codes and standards

The following outlines selected codes and standards by region or source that may be relevant to PV systems installed on roofs.

10.1. International

IEC 62305. Lightning Protection Standard including, Part 1: General Principles, Part 2: Risk Management, Part 3: Physical Damage to Structures and Life Hazard, and Part 4 Electrical and Electronic Systems Within Structures.

10.2. NFPA

NFPA 1-2021. Fire Code.

NFPA 70-2023. National Electrical Code®.

NFPA 497-2024. Recommended Practice for the Classification of Flammable Liquids, Gases, or Vapors and of Hazardous (Classified) Locations for Electrical Installations in Chemical Process Areas.

NFPA 780-2023. Standard for the Installation of Lightning Protection Systems.

10.3. Europe

EN 50521:2013-03-01. Connectors for photovoltaic systems - Safety requirements and tests.

EN 50548:2015-09-01. Junction boxes for photovoltaic modules.

EN 50618:2015-11. Electric cables for photovoltaic systems.

EN 61215: 2005-05. Crystalline silicon terrestrial photovoltaic (PV) modules - Design qualification and type approval.

EN 61439 (parts 1 through 7). Low-voltage switchgear and control gear assemblies.

EN 61724-1:2022-11. Photovoltaic system performance - Part 1: Monitoring.

EN 61730-1/A1:2020-12. Photovoltaic (PV) module safety qualification - Part 1: Requirements for construction.

EN 61730-2:2018-10. Photovoltaic (PV) module safety qualification - Part 2: Requirements for testing.

EN 62108:2017-08. Concentrator photovoltaic (CPV) modules and assemblies - Design qualification and type approval.

EN 62109-1:2013-09. Safety of power converters for use in photovoltaic power systems - Part 1: General requirements.

EN 62109-2:2012-04. Safety of power converters for use in photovoltaic power systems - Part 2: Particular requirements for inverters.

EN 62109-3:2019-04. Safety of power converters for use in photovoltaic power systems - Part 3: Particular requirements for electronic devices in combination with photovoltaic elements.

EN 62305-1:2011-10. Protection against lightning - Part 1: General principles.

EN 62305-2:2013-02. Protection against lightning - Part 2: Risk management.

EN 62305-2 Supplement 1:2013-02. Protection against lightning - Part 2: Risk management - Supplement 1: Lightning threat in Germany.

EN 62305-2 Supplement 2:2013-02. Protection against lightning - Part 2: Risk management - Supplement 2: Calculation assistance for assessment of risk for structures, with CD-ROM.

EN 62305-2 Supplement 3:2013-12. Protection against lightning - Part 2: Risk management - Supplement 3: Additional information for the application of DIN EN 62305-2.

EN 62305-3:2011-10. Protection against lightning - Part 3: Physical damage to structures and life hazard.

EN 62305-3 Supplement 1:2012-10. Protection against lightning - Part 3: Physical damage to structures and life hazard - Supplement 1: Additional information for the application of DIN EN 62305-3.

EN 62305-3 Supplement 2:2012-10. Protection against lightning - Part 3: Physical damage to structures and life hazard - Supplement 2: Additional information for special structures.

EN 62305-3 Supplement 3:2012-10. Protection against lightning - Part 3: Physical damage to structures and life hazard - Supplement 3: Additional information for the testing and maintenance of lightning protection systems.

EN 62305-3 Supplement 4:2008-01. Protection against lightning - Part 3: Physical damage to structures and life hazard - Supplement 4: Use of metallic roofs in lightning protection systems.

EN 62305-3 Supplement 5:2014-02. Protection against lightning - Part 3: Physical damage to structures and life hazard - Supplement 5: Lightning and overvoltage protection for photovoltaic power supply systems.

EN 62305-3 Supplement 6:2022-06. Protection against lightning - Part 3: Physical damage to structures and life hazard - Supplement 6: Additional information on the requirement for lightning protection according to DIN EN 62305-3.

EN 62305-4:2011-10. Protection against lightning - Part 4: Electrical and electronic systems within structures.

EN 62305-4 Supplement 1:2012-10. Protection against lightning - Part 4: Electrical and electronic systems within structures - Supplement 1: Sharing of the lightning current.

EN 62790:2015-03. Junction boxes for photovoltaic modules - Safety requirements and tests.

10.4. Germany

DIN VDE V 0100-551-1:2018-05. Low-voltage electrical installations.

VDE-AR-N 4105:2018-11. Generators connected to the low-voltage distribution network.

DIN VDE 0100-200:2023-06. Low voltage electrical installations - Part 200: Terms and definitions.

DIN VDE 0100-410:2018-10. Low-voltage electrical installations - Part 4-41: Protection for safety - Protection against electric shock.

DIN VDE 0100-420:2023-03. Low-voltage electrical installations - Part 4-42: Protection for safety - Protection against thermal effects.

DIN VDE 0100-430:2010-10. Low-voltage electrical installations - Part 4-43: Protection for safety - Protection against overcurrent.

DIN VDE 0100-443:2016-10. Low-voltage electrical installations - Part 4-44: Protection for safety - Protection against voltage disturbances and electromagnetic disturbances - Clause 443: Protection against transient over voltages of atmospheric origin or due to switching.

DIN VDE 0100-444:2010-10. Low-voltage electrical installations - Part 4-444: Protection for safety - Protection against voltage disturbances and electromagnetic disturbances.

DIN VDE 0100-520:2023-06. Low-voltage electrical installations - Part 5-52: Selection and erection of electrical equipment - Wiring systems.

DIN VDE 0100-531 Selection and erection of electrical equipment - switchgear and control devices.

DIN VDE 0100-534:2016-10. Low-voltage electrical installations - Part 5-53: Selection and erection of electrical equipment - Isolation, switching and control - Clause 534: Devices for protection against transient over voltages.

DIN VDE 0100-540:2012-06. Low-voltage electrical installations - Part 5-54: Selection and erection of electrical equipment - Earthing arrangements and protective conductors.

DIN VDE 0100-712:2022-10. Low voltage electrical installations - Part 7-712: Requirements for special installations or locations - Solar photovoltaic (PV) power supply systems.

DIN VDE 0105-100:2015-10. Operation of electrical installations - Part 100: General requirements.

DIN VDE 0124-100:2020-06. Grid integration of generator plants - Low-voltage - Test requirements for generator units to be connected to and operated in parallel with low-voltage distribution networks.

DIN EN 62109-1:2011-04. Safety of power converters for use in photovoltaic power systems - Part 1: General requirements.

DIN EN 62109-2:2012-04. Safety of power converters for use in photovoltaic power systems - Part 2: Particular requirements for inverters.

DIN EN 61215. Terrestrial photovoltaic (PV) modules - Design qualification and type approval.

VdS 3145:2017-11. Photovoltaic systems.

VdS 6023:2023-02. Photovoltaic systems on roofs with combustible building materials.

VdS 2234:2012-07. Firewalls and complex partition walls - Leaflet for arrangement and design.

VdS 2031:2021-02. Lightning and surge protection in electrical installations.

10.5. United States

UL 1703:2002. Standard for Flat-Plate Photovoltaic Modules and Panels

UL 1741:2021. Inverters, Converters, Controllers and Interconnection System Equipment for Use With Distributed Energy Resources

UL 2703:2015. Mounting Systems, Mounting Devices, Clamping/Retention Devices, and Ground Lugs for Use with Flat-Plate Photovoltaic Modules and Panels

UL 3741:2020. Photovoltaic Hazard Control

UL 4703:2014. Standard for Photovoltaic Wire

UL 6703:2014. Standard for Connectors for Use in Photovoltaic Systems

UL 9703:2018. Outline of Investigation for Distributed Generation Wiring Harnesses

UL 61730-1:2022. Photovoltaic (PV) Module Safety Qualification - Part 1: Requirements for Construction

UL 61730-2:2022. Photovoltaic (PV) Module Safety Qualification - Part 2: Requirements for Testing

UL 62093:21017. Balance-of-System Components for Photovoltaic Systems – Design Qualification Natural Environments

Appendix A – Pre-design checklist

The following is a checklist of items to consider during the pre-design phase of a PV system. Provide comments for items marked “No”.

A.1 Consider developing an internal corporate policy on PV systems	
A.1.1 Has a corporate policy been developed?	<input type="checkbox"/> Yes <input type="checkbox"/> No <input type="checkbox"/> NA
A.2 Rooftop PV system ownership	
A.2.1 Another party will not own the PV system.	<input type="checkbox"/> Yes <input type="checkbox"/> No <input type="checkbox"/> NA
A.3 Identify rooftop areas not to be occupied by PV systems	
A.3.1 No unoccupied areas needed for equipment or process vents?	<input type="checkbox"/> Yes <input type="checkbox"/> No <input type="checkbox"/> NA
A.3.2 No unoccupied areas needed above water-susceptible operations?	<input type="checkbox"/> Yes <input type="checkbox"/> No <input type="checkbox"/> NA
A.3.3 No unoccupied areas needed above high-hazard occupancies?	<input type="checkbox"/> Yes <input type="checkbox"/> No <input type="checkbox"/> NA
A.4 Local codes, fire service, and facilities staff special distance or spacing guidance	
A.4.1 The local codes and standards have no special guidance.	<input type="checkbox"/> Yes <input type="checkbox"/> No <input type="checkbox"/> NA
A.4.2 The local fire service has no special guidance.	<input type="checkbox"/> Yes <input type="checkbox"/> No <input type="checkbox"/> NA
A.4.3 The facilities staff have no special guidance.	<input type="checkbox"/> Yes <input type="checkbox"/> No <input type="checkbox"/> NA
A.5 Roof and electrical system reviews	
A.5.1 Has the building been reviewed by a qualified structural engineer?	<input type="checkbox"/> Yes <input type="checkbox"/> No <input type="checkbox"/> NA
A.5.2 Is the roof considered a candidate for a PV system?	<input type="checkbox"/> Yes <input type="checkbox"/> No <input type="checkbox"/> NA
A.5.3 Has the electrical system and utility system been	<input type="checkbox"/> Yes <input type="checkbox"/> No <input type="checkbox"/> NA
A.6 Review of flood, hail, lightning, and wind	
A.6.1 Zurich's flood rating has been reviewed for fluvial (river), pluvial (runoff), and storm surge (coastal) flooding.	<input type="checkbox"/> Yes <input type="checkbox"/> No <input type="checkbox"/> NA
A.6.2 Zurich's hail rating has been established.	<input type="checkbox"/> Yes <input type="checkbox"/> No <input type="checkbox"/> NA
A.6.3 Zurich's lightning rating has been established.	<input type="checkbox"/> Yes <input type="checkbox"/> No <input type="checkbox"/> NA
A.6.4 The minimum design wind speed has been identified (for global locations use CRI or local maps, and for US locations use www.hazards.atccouncil.org using ASCE 7-16 and Risk Category II or higher).	<input type="checkbox"/> Yes <input type="checkbox"/> No <input type="checkbox"/> NA
A.7 Recommended roof upgrades	
A.7.1 The proposed PV system will not affect the roof warranty?	<input type="checkbox"/> Yes <input type="checkbox"/> No <input type="checkbox"/> NA
A.7.2 Does the roof system life expectancy meet or exceed the PV system life expectancy?	<input type="checkbox"/> Yes <input type="checkbox"/> No <input type="checkbox"/> NA

Photovoltaic (PV) systems on buildings
Design, installation, and operation

A.7.3 Fill around all roof penetrations is noncombustible?	<input type="checkbox"/> Yes <input type="checkbox"/> No <input type="checkbox"/> NA
A.7.4 A thermal barrier for polyurethane insulation or a wood deck has been provided.	<input type="checkbox"/> Yes <input type="checkbox"/> No <input type="checkbox"/> NA
A.7.5 Fixed fire protection is planned for roofs with EDPM (rubber) membranes or expanded or extruded polystyrene insulations.	<input type="checkbox"/> Yes <input type="checkbox"/> No <input type="checkbox"/> NA
A.8 Green roofs	
A.8.1 The location will not have a green roof.	<input type="checkbox"/> Yes <input type="checkbox"/> No <input type="checkbox"/> NA
A.8.2 Has a green roof membrane maintenance program been developed?	<input type="checkbox"/> Yes <input type="checkbox"/> No <input type="checkbox"/> NA
A.8.3 Will extensive vegetation be kept 0.3 m (1 ft.) from the PV system? Note: Extensive vegetation is not more than 200 mm (7 in.) tall.	<input type="checkbox"/> Yes <input type="checkbox"/> No <input type="checkbox"/> NA
A.8.4 Will intensive vegetation be kept 5 m (15 ft.) from the PV system? Note: Intensive vegetation is more than 200 mm (7 in.) tall.	<input type="checkbox"/> Yes <input type="checkbox"/> No <input type="checkbox"/> NA
A.8.5 Has a qualified person determined the needed green roof soil type and depth?	<input type="checkbox"/> Yes <input type="checkbox"/> No <input type="checkbox"/> NA
A.8.6 Has a monthly vegetation inspection program been established?	<input type="checkbox"/> Yes <input type="checkbox"/> No <input type="checkbox"/> NA
A.8.7 Has a maintenance program been established?	<input type="checkbox"/> Yes <input type="checkbox"/> No <input type="checkbox"/> NA
A.9 Firewalls	
A.9.1 There are no firewalls identified.	<input type="checkbox"/> Yes <input type="checkbox"/> No <input type="checkbox"/> NA
A.9.2 Have firewall parapet heights been identified?	<input type="checkbox"/> Yes <input type="checkbox"/> No <input type="checkbox"/> NA
A.10 Roof documentation	
A.10.1 Has a layer-by-layer roof system description been prepared?	<input type="checkbox"/> Yes <input type="checkbox"/> No <input type="checkbox"/> NA
A.10.2 Has a roof drawing been prepared showing roof areas to remain unoccupied, any identified applicable local codes, local special fire service requests, penetrations, rooftop equipment, roof elevation changes, green roof areas, and firewalls?	<input type="checkbox"/> Yes <input type="checkbox"/> No <input type="checkbox"/> NA
A.11 Choosing a PV system designer	
A.11.1 Is the designer a qualified electrical engineer or electrician?	<input type="checkbox"/> Yes <input type="checkbox"/> No <input type="checkbox"/> NA
A.11.2 Does the designer have added PV-specific certifications?	<input type="checkbox"/> Yes <input type="checkbox"/> No <input type="checkbox"/> NA
A.11.3 Does the designer have relevant work experience? Note: Consider experience with commercial or industrial rooftop PV systems.	<input type="checkbox"/> Yes <input type="checkbox"/> No <input type="checkbox"/> NA
A.11.4 Does the designer have favorable references? Note: Consider references from commercial or industrial businesses, especially Fortune 500 companies. In addition, consider repeat customers.	<input type="checkbox"/> Yes <input type="checkbox"/> No <input type="checkbox"/> NA

Photovoltaic (PV) systems on buildings
Design, installation, and operation

A.12 Choosing a PV system installer	
A.12.1 Is the installer a qualified electrical engineer or electrician?	<input type="checkbox"/> Yes <input type="checkbox"/> No <input type="checkbox"/> NA
A.12.2 Does the installer have an added PV-specific certification?	<input type="checkbox"/> Yes <input type="checkbox"/> No <input type="checkbox"/> NA
A.12.3 Does the installer have relevant work experience? Note: Consider experience with commercial or industrial rooftop PV systems.	<input type="checkbox"/> Yes <input type="checkbox"/> No <input type="checkbox"/> NA
A.12.4 Does the installer have favorable references? Note: Consider references from commercial or industrial businesses, especially Fortune 500 companies. In addition, consider repeat customers.	<input type="checkbox"/> Yes <input type="checkbox"/> No <input type="checkbox"/> NA
A.13 Choosing a PV system maintenance contractor	
A.13.1 Is the maintenance contractor a qualified electrical engineer or electrician?	<input type="checkbox"/> Yes <input type="checkbox"/> No <input type="checkbox"/> NA
A.13.2 Does the maintenance contractor have an added PV-specific certification?	<input type="checkbox"/> Yes <input type="checkbox"/> No <input type="checkbox"/> NA
A.13.3 Does the maintenance contractor have relevant work experience? Note: Consider experience with commercial or industrial rooftop PV systems.	<input type="checkbox"/> Yes <input type="checkbox"/> No <input type="checkbox"/> NA
A.13.4 Does the maintenance contractor have favorable references? Note: Consider references from commercial or industrial businesses, especially Fortune 500 companies. In addition, consider repeat customers.	<input type="checkbox"/> Yes <input type="checkbox"/> No <input type="checkbox"/> NA
Comments	

Appendix B – Design documentation checklist

The following is a checklist of recommended data to be included in the PV system design documents. This data is to be submitted to Zurich for review and comment in accordance with section 4.12. Provide comments for items marked “No”.

Note: It is anticipated that separate plan submittals will be needed for:

- Roofing system upgrades in preparation for the rooftop PV system
- Fire detection systems (all rooftop PV systems)
- Lightning protection systems (when needed)
- Fire protection system (when needed)

B.1 Contact information (business name, contact name, address, telephone, email, etc.)	
B.1.1 Building owner	<input type="checkbox"/> Yes <input type="checkbox"/> No <input type="checkbox"/> NA
B.1.2 PV system owner	<input type="checkbox"/> Yes <input type="checkbox"/> No <input type="checkbox"/> NA
B.1.3 PV system designer	<input type="checkbox"/> Yes <input type="checkbox"/> No <input type="checkbox"/> NA
B.2 Building information	
B.2.1 Address	<input type="checkbox"/> Yes <input type="checkbox"/> No <input type="checkbox"/> NA
B.2.2 Latitude and longitude	<input type="checkbox"/> Yes <input type="checkbox"/> No <input type="checkbox"/> NA
B.2.3 Construction	<input type="checkbox"/> Yes <input type="checkbox"/> No <input type="checkbox"/> NA
B.2.4 Number of stories	<input type="checkbox"/> Yes <input type="checkbox"/> No <input type="checkbox"/> NA
B.2.5 Occupancy	<input type="checkbox"/> Yes <input type="checkbox"/> No <input type="checkbox"/> NA
B.2.6 Description of building fire alarm system (if provided)	<input type="checkbox"/> Yes <input type="checkbox"/> No <input type="checkbox"/> NA
B.3 Codes and standards	
B.3.1 Codes and standards – Documents specify the names and dates of the codes and standards applicable to the PV system	<input type="checkbox"/> Yes <input type="checkbox"/> No <input type="checkbox"/> NA
B.3.2. Codes and standards compliance – Documents specify the PV system is to comply with the specified codes and standards.	<input type="checkbox"/> Yes <input type="checkbox"/> No <input type="checkbox"/> NA
B.4 Zurich identified natural hazards	
B.4.1 Earthquake – Zurich identified hazard level	<input type="checkbox"/> Yes <input type="checkbox"/> No <input type="checkbox"/> NA
B.4.2 Flood – Zurich identified flood hazards that may include fluvial (river), pluvial (runoff), or storm surge (coastal), along with any associated water elevations	<input type="checkbox"/> Yes <input type="checkbox"/> No <input type="checkbox"/> NA
B.4.3 Hail - Zurich identified hazard level	<input type="checkbox"/> Yes <input type="checkbox"/> No <input type="checkbox"/> NA
B.4.4 Lightning - Zurich identified hazard level	<input type="checkbox"/> Yes <input type="checkbox"/> No <input type="checkbox"/> NA
B.4.5 Wind – Zurich identified minimum design wind speed	<input type="checkbox"/> Yes <input type="checkbox"/> No <input type="checkbox"/> NA

**Photovoltaic (PV) systems on buildings
Design, installation, and operation**

B.5 Wind design	
B.5.1 Wind uplift pressures – Calculations or wind tunnel test results have been provided to support the wind uplift pressures used in the wind design calculations.	<input type="checkbox"/> Yes <input type="checkbox"/> No <input type="checkbox"/> NA
B.5.2 Rack securement – Design details are provided showing: <ul style="list-style-type: none"> • Securement of the PV modules to the racks • Rack components and fasteners • Rack securement to the building structure (fasteners to structural elements or ballasting) 	<input type="checkbox"/> Yes <input type="checkbox"/> No <input type="checkbox"/> NA
B.5.3 Wind design calculations – Wind resistance calculations prepared by a qualified structural engineer based on the Zurich recommended minimum design wind speed design (or higher) and the calculated wind uplift loads (or loads established by wind tunnel testing) confirming each connection in the load path from the PV module to the building structure or ballast.	<input type="checkbox"/> Yes <input type="checkbox"/> No <input type="checkbox"/> NA
B.6 Earthquake design	
B.6.1 Design calculations – Earthquake design calculations prepared by a qualified structural engineer verifying that the PV system mechanical fasteners and ballast are expected to resist horizontal and vertical earthquake loads.	<input type="checkbox"/> Yes <input type="checkbox"/> No <input type="checkbox"/> NA
B.7 Structural load review	
B.7.1 Design calculations – Calculations prepared by a qualified structural engineer are provided and verify that the added PV system loads can be supported by the building structure along with any required upgrades.	<input type="checkbox"/> Yes <input type="checkbox"/> No <input type="checkbox"/> NA
B.7.2 Structural upgrades – Where the qualified structural engineer determines that structural upgrades are required to support the PV system, documentation is included confirming that the upgrades have been completed.	<input type="checkbox"/> Yes <input type="checkbox"/> No <input type="checkbox"/> NA
B.8 PV array movement tracking	
B.8.1 Design documents include exact distances between PV arrays and fixed rooftop points (e.g., construction features or rooftop equipment) to support array movement tracking.	<input type="checkbox"/> Yes <input type="checkbox"/> No <input type="checkbox"/> NA
B.8.2 The design documents require the installer to confirm the PV array distances to fixed rooftop points and include any adjustments on the as-built drawings.	<input type="checkbox"/> Yes <input type="checkbox"/> No <input type="checkbox"/> NA
B.8.3 Design documents specify that the installer is to mark the location of each array corner using a method (e.g., paint) acceptable to the roof cover manufacturer.	<input type="checkbox"/> Yes <input type="checkbox"/> No <input type="checkbox"/> NA
B.9 PV system components	
B.9.1 The PV system uses microinverters or optimizers.	<input type="checkbox"/> Yes <input type="checkbox"/> No <input type="checkbox"/> NA
B.9.2 Listing – The design documents specify independent, third-party laboratory listing of system components, including the PV modules, connectors, microinverters, optimizers, and inverters.	<input type="checkbox"/> Yes <input type="checkbox"/> No <input type="checkbox"/> NA

Photovoltaic (PV) systems on buildings
Design, installation, and operation

Note: Zurich will advise if any noted independent, third-party testing laboratory is not a Zurich Recognized Testing Laboratory.	
<p>B.9.3 Listed compatibility of optimizers and inverters – The design documents include independent, third-party laboratory documentation confirming that the selected optimizers and inverters are compatible for use together.</p> <p>Note: Zurich will advise if any noted independent, third-party testing laboratory is not a Zurich Recognized Testing Laboratory.</p>	<input type="checkbox"/> Yes <input type="checkbox"/> No <input type="checkbox"/> NA
B.9.4 Connector compatibility – Design documents specify that every set of connector halves that are to be mated are made by the same manufacturer and are the same type.	<input type="checkbox"/> Yes <input type="checkbox"/> No <input type="checkbox"/> NA
B.9.5 Connectors and field assembly – Do design documents specify that field-installed connectors will be made using manufacturer-approved tools and methods?	<input type="checkbox"/> Yes <input type="checkbox"/> No <input type="checkbox"/> NA
B.9.6 Connector dust and water tightness – Design documents specify that PV connectors are to have a rating of at least IP65 per IEC 60529, <i>Degrees of Protection Provided by Enclosures (IP Code)</i> .	<input type="checkbox"/> Yes <input type="checkbox"/> No <input type="checkbox"/> NA
<p>B.9.7 PV modules – Design document specify PV modules storage and handling guidelines, including:</p> <ul style="list-style-type: none"> • Storage in a dry location • Where stored at a remote location, delivered just in time to the job site for installation that day • Not allowing PV modules outdoors with open, unmated connectors when it is raining or surfaces are wet. • In hurricane-prone regions, having a plan to complete all wind resisting features for installed PV components once a hurricane or tropical storm watch is issued. Also, having the plan include moving all unsecured material from the building roof to an indoor location. • As PV modules are unpackaged, they are to be installed and connectors mated with a minimum delay to reduce the chance of connector contamination by dust, debris, moisture, or water 	<input type="checkbox"/> Yes <input type="checkbox"/> No <input type="checkbox"/> NA
B.9.8 PV modules hail resistance – Where the Zurich hail rating is medium, high, or very high, PV modules are specified with the highest available hail rating per IEC 61730 or UL 61730.	<input type="checkbox"/> Yes <input type="checkbox"/> No <input type="checkbox"/> NA
B.10 Automatic PV system shutdown	
B.10.1 The PV system design includes automatically disconnecting via optimizers or microinverters upon detection of arc faults or ground faults.	<input type="checkbox"/> Yes <input type="checkbox"/> No <input type="checkbox"/> NA
B.11 Rapid shutdown switch	
<p>B.11.1 The PV system design includes a manual disconnect switch for fire service use to initiate PV system shutdown so that within 30 seconds of switch operation, the system voltage does not exceed:</p> <ul style="list-style-type: none"> • 30 volts more than 0.3 m (1 ft.) beyond the arrays • 80 volts within an array or 0.3 m (1 ft.) of an array 	<input type="checkbox"/> Yes <input type="checkbox"/> No <input type="checkbox"/> NA

Photovoltaic (PV) systems on buildings
Design, installation, and operation

B.12 PV system fault monitoring	
<p>B.12.1 The PV system documentation includes:</p> <ul style="list-style-type: none"> • A list of the faults to be monitored and recorded by the system • A list of the faults that will cause automatic system shutdown 	<input type="checkbox"/> Yes <input type="checkbox"/> No <input type="checkbox"/> NA
B.13 PV system electrical requirements	
<p>B.13.1 The PV system documentation includes:</p> <ul style="list-style-type: none"> • Surge protection features • Bonding and grounding of all conductive, non-current-carrying system components • Wiring and cable specifications • Conduit (raceway) and cable tray specifications • Conduit thermal expansion devices, including the make, model, and locations • Dissimilar metals specifications – Methods to avoid corrosion 	<input type="checkbox"/> Yes <input type="checkbox"/> No <input type="checkbox"/> NA
B.14 PV modules and arrays diagrams – Diagrams including:	
B.14.1 Site plan showing location of PV system.	<input type="checkbox"/> Yes <input type="checkbox"/> No <input type="checkbox"/> NA
B.14.2 Roof areas to be kept clear of PV system components	<input type="checkbox"/> Yes <input type="checkbox"/> No <input type="checkbox"/> NA
<p>B.14.3 PV module spacing from expansion joints, seismic joints, roof drains, and other smaller roof penetrations</p> <p>Note: At least 300 mm (12 in.) except for roof drains, which is at least 600 mm (24 in.)</p>	<input type="checkbox"/> Yes <input type="checkbox"/> No <input type="checkbox"/> NA
<p>B.14.4 PV module spacing from smoke and heat vents, roof hatches, rooftop equipment, and other larger roof penetrations</p> <p>Note: At least 1.2 m (4 ft.)</p>	<input type="checkbox"/> Yes <input type="checkbox"/> No <input type="checkbox"/> NA
<p>B.14.5 PV module spacing from firewalls</p> <p>Note: Keep PV modules 2.5 m (8 ft.) from firewalls. Where the firewall parapet extends at least 0.5 m (18 in.) above the highest point of the PV modules, the separation distance may be reduced to 1.2 m (4 ft.)</p>	<input type="checkbox"/> Yes <input type="checkbox"/> No <input type="checkbox"/> NA
<p>B.14.6 PV array roof edge setbacks</p> <p>Note: At least 1.2 m (4 ft.)</p>	<input type="checkbox"/> Yes <input type="checkbox"/> No <input type="checkbox"/> NA
<p>B.14.7 PV module spacing from roof elevation changes</p> <p>Note: At least 5 m (15 ft.) from roof elevation changes, except that this distance may be reduced to 1.2 m (4 ft.) where the wall at the elevation change is fire-resistant and does not have unprotected opening.</p>	<input type="checkbox"/> Yes <input type="checkbox"/> No <input type="checkbox"/> NA
<p>B.14.8 PV array size and spacing</p> <p>Note: Keep PV arrays separated by walkways at least 1.2 m (4 ft.) wide and spaced not more than 45 m (150 ft.) apart</p>	<input type="checkbox"/> Yes <input type="checkbox"/> No <input type="checkbox"/> NA

Photovoltaic (PV) systems on buildings
Design, installation, and operation

B.14.9 PV system walkways for firefighter access provided per local code	<input type="checkbox"/> Yes <input type="checkbox"/> No <input type="checkbox"/> NA
B.14.10 Optimizer or microinverter locations	<input type="checkbox"/> Yes <input type="checkbox"/> No <input type="checkbox"/> NA
B.14.11 Junction box (combiner box) locations	<input type="checkbox"/> Yes <input type="checkbox"/> No <input type="checkbox"/> NA
B.14.12 PV string diagram	<input type="checkbox"/> Yes <input type="checkbox"/> No <input type="checkbox"/> NA
B.14.13 Cable pathways (conduits or cable trays)	<input type="checkbox"/> Yes <input type="checkbox"/> No <input type="checkbox"/> NA
B.14.14 Inverter locations	<input type="checkbox"/> Yes <input type="checkbox"/> No <input type="checkbox"/> NA
B.14.15 Disconnect locations	<input type="checkbox"/> Yes <input type="checkbox"/> No <input type="checkbox"/> NA
B.14.16 Rapid shutdown switch locations	<input type="checkbox"/> Yes <input type="checkbox"/> No <input type="checkbox"/> NA
B.14.17 Electrical room diagram	<input type="checkbox"/> Yes <input type="checkbox"/> No <input type="checkbox"/> NA
B.14.18 PV system single line diagram	<input type="checkbox"/> Yes <input type="checkbox"/> No <input type="checkbox"/> NA
B.14.19 PV system component locations with respect to roof drainage and roof drains verifying the PV system is not expected to interfere with rainwater drainage from the roof	<input type="checkbox"/> Yes <input type="checkbox"/> No <input type="checkbox"/> NA
B.14.20 PV system component locations with respect to flood hazards	<input type="checkbox"/> Yes <input type="checkbox"/> No <input type="checkbox"/> NA
B.14.21 PV system signage and labels	<input type="checkbox"/> Yes <input type="checkbox"/> No <input type="checkbox"/> NA
B.14.22 Fire service diagram providing information including: <ul style="list-style-type: none"> • Location of fire service vehicle access points • Location of roof access (stairs, perimeter PV module setbacks) • Location of firefighting water supplies • Location of firefighting hose connections or riser (standpipes) • Location of the photovoltaic modules and walkways • Location of normally energized wires and components • Location of disconnect switches • Location of rapid shutdown switches 	<input type="checkbox"/> Yes <input type="checkbox"/> No <input type="checkbox"/> NA
B.15 PV system product literature	
B.15.1 Bill of materials – A list including the make, model, and number of each system component	<input type="checkbox"/> Yes <input type="checkbox"/> No <input type="checkbox"/> NA
B.15.2 Manufacturer’s literature – Product literature for each component	<input type="checkbox"/> Yes <input type="checkbox"/> No <input type="checkbox"/> NA
B.15.3 Options – Manufacturer’s literature marked to indicate all selected options	<input type="checkbox"/> Yes <input type="checkbox"/> No <input type="checkbox"/> NA
B.16 Installation, commission, and periodic inspections	
B.16.1 Specifications for installation instructions (consider items addressed in Appendix C)	<input type="checkbox"/> Yes <input type="checkbox"/> No <input type="checkbox"/> NA
B.16.2 Specifications for commissioning instructions (consider items addressed in Appendix D)	<input type="checkbox"/> Yes <input type="checkbox"/> No <input type="checkbox"/> NA

Photovoltaic (PV) systems on buildings
Design, installation, and operation

B.16.3 Specifications for periodic inspection, testing, and maintenance instructions (consider items addressed in Appendix E, F, and G)	<input type="checkbox"/> Yes <input type="checkbox"/> No <input checked="" type="checkbox"/> NA
Comments:	

Appendix C – Installation checklist

In preparation for installation, have the installer’s representative and independent, third-party quality assurance person use the following checklist to verify practices to be implemented during the PV system installation. Provide comments for items marked “No”.

C.1 PV system installation quality assurance person duties	
<p>C.1.1 An independent, third-party quality assurance person has been hired for the project to:</p> <ul style="list-style-type: none"> • Monitor the PV system installation, specifically the “golden row” (see section 2.9.2). • Confirm that the PV system is being installed in accordance with the design documents. • Notify the installer, PV system owner, and building owner of any identified installation deviations from the design documents. • Verify that noted installation deviations have been resolved. • Document to the installer, PV system owner, and building owner any noted deviations, their resolution, and a final report when the project is complete and any deviations are resolved. 	<input type="checkbox"/> Yes <input type="checkbox"/> No <input type="checkbox"/> NA
C.2 PV system installation – Installer’s representative duties	
<p>C.2.1 A qualified installer’s representative will be on-site to:</p> <ul style="list-style-type: none"> • Manage and supervise the PV system installation and specifically manage and supervise the installation of the “golden row” (see section 2.9.2). • Confirm that the PV system is being installed in accordance with the design documents. • Notify the independent, third-party quality assurance person, PV system owner, and building owner of any identified installation deviations from the design documents. • Notify the building owner of any roof damage promptly. • Verify that noted installation deviations have been resolved. • Document the following to the independent, third-party quality assurance person, PV system owner, and building owner: <ul style="list-style-type: none"> – Any noted deviations – The resolution of any noted deviations – A final report when the project is complete and any deviations are resolved – As-built design documents 	<input type="checkbox"/> Yes <input type="checkbox"/> No <input type="checkbox"/> NA
C.3 PV system installation - General practices	
<p>C.3.1 Control of contamination and damage - Provide means to store PV system electrical components from the time they are received until installed with all electrical connections completed and enclosed to help minimize the potential for contamination and physical damage</p>	<input type="checkbox"/> Yes <input type="checkbox"/> No <input type="checkbox"/> NA
<p>C.3.2 PV module handling – Provide methods for handling PV modules to avoid damage caused by impact, falling, and bending</p>	<input type="checkbox"/> Yes <input type="checkbox"/> No <input type="checkbox"/> NA

Photovoltaic (PV) systems on buildings
Design, installation, and operation

C.3.3 Roof loads – Provide practices approved by the structural engineer to distribute PV components being stored on the roof and awaiting installation to avoid roof overloading	<input type="checkbox"/> Yes <input type="checkbox"/> No <input type="checkbox"/> NA
C.3.4 Roof damage – Notify the building owner of any damage to the roof during the PV system installation so it may be repaired promptly. Note: Roof cover repairs may need to be completed before installing the PV modules. Note: Roof repairs may need to be completed by a qualified contractor to maintain any roof warranty that may be available.	<input type="checkbox"/> Yes <input type="checkbox"/> No <input type="checkbox"/> NA
C.3.5 Component placement - Install PV system components in accordance with the design documents	<input type="checkbox"/> Yes <input type="checkbox"/> No <input type="checkbox"/> NA
C.3.6 Deviations – Where the PV system installation deviates from the design documents, resolve the deviations in a manner acceptable to the designer and third-party quality assurance person	<input type="checkbox"/> Yes <input type="checkbox"/> No <input type="checkbox"/> NA
C.3.7 As-built documents – Create as-built PV system documents to capture accepted deviations (changes)	<input type="checkbox"/> Yes <input type="checkbox"/> No <input type="checkbox"/> NA
C.3.8 Hurricane-prone regions - A plan is in place to complete all wind resisting features for installed PV components once a hurricane or tropical storm watch is issued. Also, the plan includes moving all unsecured material from the building roof to an indoor location.	<input type="checkbox"/> Yes <input type="checkbox"/> No <input type="checkbox"/> NA
C.4 PV system installation – Electrical practices	
C.4.1 Cable ends - Protect cable ends until weather-tight connections are formed	<input type="checkbox"/> Yes <input type="checkbox"/> No <input type="checkbox"/> NA
C.4.2 Cable ends - Do not allow any PV system cable ends to sit in water (e.g., rainwater) during installation	<input type="checkbox"/> Yes <input type="checkbox"/> No <input type="checkbox"/> NA
C.4.3 Cable ends - Cable ends subjected to water or other forms of contamination should not become part of the final installation	<input type="checkbox"/> Yes <input type="checkbox"/> No <input type="checkbox"/> NA
C.4.4 Cables- Install all system cables to minimize the likelihood of physical injury and exposure to sunlight by locating cables under PV modules or in conduits, cable trays, or other cable management systems	<input type="checkbox"/> Yes <input type="checkbox"/> No <input type="checkbox"/> NA
C.4.5 Cables - Handle cables during installation to avoid insulation damage (cable insulation may be damaged as they are pulled through conduit or pulled across edges or surfaces)	<input type="checkbox"/> Yes <input type="checkbox"/> No <input type="checkbox"/> NA
C.4.6 Cables - Handle cables during installation to avoid subjecting cables to a bending radius that exceeds the limits established by the cable manufacturer	<input type="checkbox"/> Yes <input type="checkbox"/> No <input type="checkbox"/> NA
C.4.7 Cables - Install cables routed under PV modules so they are not pinched between features such as PV modules and their support racks	<input type="checkbox"/> Yes <input type="checkbox"/> No <input type="checkbox"/> NA
C.4.8 Cables – Support and secure PV cables under PV modules to avoid cable flexing (e.g., due to wind) and cable abrasion (e.g., due to rubbing against adjacent materials such as a roof)	<input type="checkbox"/> Yes <input type="checkbox"/> No <input type="checkbox"/> NA
C.4.9 – Cables – Ordinary plastic tie-wraps are not used to secure or support cables.	<input type="checkbox"/> Yes <input type="checkbox"/> No <input type="checkbox"/> NA

Photovoltaic (PV) systems on buildings
Design, installation, and operation

<p>C.4.10 Cables – Provide cable loops at junction boxes (combiner boxes) to avoid transferring loads from conduits to cables (e.g., during expansion and contraction).</p>	<p><input type="checkbox"/> Yes <input type="checkbox"/> No <input type="checkbox"/> NA</p>
<p>C.4.11 Cable connectors – Support and secure PV cable connectors above sources of water such as rainwater drainage</p>	<p><input type="checkbox"/> Yes <input type="checkbox"/> No <input type="checkbox"/> NA</p>
<p>C.4.12 Cable connectors – Crimp cable connectors onto cables following manufacturer guidelines, including the use of the manufacturer’s recommended crimping tool</p>	<p><input type="checkbox"/> Yes <input type="checkbox"/> No <input type="checkbox"/> NA</p>
<p>C.4.13 Conduits - Threaded conduit fittings are avoided.</p> <p>Note: Conduit threading removes material from the conduit wall. Reduced wall thickness may also reduce corrosion resistance, increasing the likelihood of a conduit failure at the cut threads. Such failures may expose cables to abrasion, leading to electrical faults and possible fire ignition sources.</p>	<p><input type="checkbox"/> Yes <input type="checkbox"/> No <input type="checkbox"/> NA</p>
<p>C.4.14 Cable trays - Install cable tray covers so they are securely attached to resist wind loads</p>	<p><input type="checkbox"/> Yes <input type="checkbox"/> No <input type="checkbox"/> NA</p>
<p>Comments:</p>	

Appendix D – Commissioning checklist

In preparation for commissioning, have the installer’s representative and independent, third-party quality assurance person use the following checklist to verify practices to be implemented during the PV system commissioning. Provide comments for items marked “No”.

D.1 PV system installation - Quality assurance person duties	
<p>D.1.1 An independent, third-party quality assurance person has been hired for the project to:</p> <ul style="list-style-type: none"> • Monitor the PV system commissioning. • Verify that the PV system commissioning plan is appropriate for the specific installation. • Document to the installer, PV system owner, and building owner any noted commissioning issues, their resolution, and a final report when commissioning is complete and any issues are resolved. 	<input type="checkbox"/> Yes <input type="checkbox"/> No <input type="checkbox"/> NA
D.2 PV system installation – Installer’s representative duties	
<p>D.2.1 A qualified installer’s representative will be on-site to:</p> <ul style="list-style-type: none"> • Manage and supervise the PV system commissioning. • Provide a commission plan appropriate for the specific installation. • Document the following to the independent, third-party quality assurance person, PV system owner, and building owner: <ul style="list-style-type: none"> – Any commissioning issues – The resolution of any commissioning issues – A final report when commissioning is complete documenting all activities and results 	<input type="checkbox"/> Yes <input type="checkbox"/> No <input type="checkbox"/> NA
D.3 Cold commissioning practices (selected measures to reduce fire likelihood)	
D.3.1 All installation work is complete	<input type="checkbox"/> Yes <input type="checkbox"/> No <input type="checkbox"/> NA
D.3.2 Do the installed components agree with the specified materials?	<input type="checkbox"/> Yes <input type="checkbox"/> No <input type="checkbox"/> NA
D.3.3 Are the components installed according to the manufacturer's specifications?	<input type="checkbox"/> Yes <input type="checkbox"/> No <input type="checkbox"/> NA
D.3.4 Are all circuits complete, secure, protected from physical injury, and weather-tight?	<input type="checkbox"/> Yes <input type="checkbox"/> No <input type="checkbox"/> NA
D.3.5 Are all non-current-carrying metal parts bonded and grounded?	<input type="checkbox"/> Yes <input type="checkbox"/> No <input type="checkbox"/> NA
D.3.6 Are all system components mounted securely and show no signs of physical damage?	<input type="checkbox"/> Yes <input type="checkbox"/> No <input type="checkbox"/> NA
D.3.7 Are all required labels installed?	<input type="checkbox"/> Yes <input type="checkbox"/> No <input type="checkbox"/> NA
D.3.8 Are all building penetrations weather-tight using a listed firestopping material?	<input type="checkbox"/> Yes <input type="checkbox"/> No <input type="checkbox"/> NA
D.3.9 Are photovoltaic module leads supported to avoid transmitting loads to the PV module junction boxes?	<input type="checkbox"/> Yes <input type="checkbox"/> No <input type="checkbox"/> NA

Photovoltaic (PV) systems on buildings
Design, installation, and operation

D.3.10 Are photovoltaic module leads supported to avoid flexing when exposed to wind?	<input type="checkbox"/> Yes <input type="checkbox"/> No <input type="checkbox"/> NA
D.3.11 Are photovoltaic module leads supported to avoid contact with the roof?	<input type="checkbox"/> Yes <input type="checkbox"/> No <input type="checkbox"/> NA
D.3.12 Is all wiring protected from sharp edges and pinching?	<input type="checkbox"/> Yes <input type="checkbox"/> No <input type="checkbox"/> NA
D.3.13 Is wiring protected with conduit or other suitable means when passing between module rows or beyond the PV modules and array?	<input type="checkbox"/> Yes <input type="checkbox"/> No <input type="checkbox"/> NA
D.3.14 Has the polarity of each string been verified?	<input type="checkbox"/> Yes <input type="checkbox"/> No <input type="checkbox"/> NA
D.3.15 Has the open circuit voltage of each string been measured and recorded?	<input type="checkbox"/> Yes <input type="checkbox"/> No <input type="checkbox"/> NA
D.3.16 Has the short-circuit current for each string been measured and recorded?	<input type="checkbox"/> Yes <input type="checkbox"/> No <input type="checkbox"/> NA
D.3.17 Has the insulation for each circuit been tested and recorded? (Note: This testing intends to identify any cable insulations damaged during installation so they may be corrected and provide reference values for future ground fault troubleshooting.)	<input type="checkbox"/> Yes <input type="checkbox"/> No <input type="checkbox"/> NA
D.4 Hot commissioning practices (selected measures to reduce fire likelihood)	
D.4.1 Has electrical infrared testing been completed for junction boxes, inverters, and other electrical enclosures? (Note: This testing intends to identify hot spots due to conditions such as loose connections.)	<input type="checkbox"/> Yes <input type="checkbox"/> No <input type="checkbox"/> NA
D.4.2 Has PV array infrared testing been completed for the PV modules? (Note: This testing intends to identify PV modules that are hotter than the surrounding modules. This may involve an entire module or parts of a module. Investigate hot spots to identify any need for corrective action.)	<input type="checkbox"/> Yes <input type="checkbox"/> No <input type="checkbox"/> NA
D.4.3 Have ground, arc, inverter, and any other faults detected by the PV system been tested to verify appropriate actions (automatic shutdown) and signaling to the remote monitoring points?	<input type="checkbox"/> Yes <input type="checkbox"/> No <input type="checkbox"/> NA
D.5 Owner documentation and training	
D.5.1 Has a complete set of system as-built documentation been provided to the PV system and building owner?	<input type="checkbox"/> Yes <input type="checkbox"/> No <input type="checkbox"/> NA
D.5.2 Has owner education been provided to selected staff? (Note: The training should include system operation, system disconnect sequence, system monitoring data, maintenance practices, fault response practices, and emergency response practices.)	<input type="checkbox"/> Yes <input type="checkbox"/> No <input type="checkbox"/> NA
D.5.3 Has emergency and maintenance contact information been provided?	<input type="checkbox"/> Yes <input type="checkbox"/> No <input type="checkbox"/> NA
Comments:	

Appendix E – Rooftop self-inspection checklist

The following is an outline of rooftop self-inspection activities for use by the building owner to monitor the rooftop once the PV system is operating. Provide comments for items marked “No”.

E.1 Rooftop self-inspection	
E.1.1 No rooftop vegetation or debris observed?	<input type="checkbox"/> Yes <input type="checkbox"/> No <input type="checkbox"/> NA
E.1.2 No debris or dirt on the PV modules, including bird waste?	<input type="checkbox"/> Yes <input type="checkbox"/> No <input type="checkbox"/> NA
E.1.3 No signs of PV system component movement (e.g., movement due to high winds or seismic activity)? Note: The corners of each PV array should be marked (see section 4.3.3)	<input type="checkbox"/> Yes <input type="checkbox"/> No <input type="checkbox"/> NA
E.1.4 No visual signs of loose PV system components, including cables, conduit, modules, etc.?	<input type="checkbox"/> Yes <input type="checkbox"/> No <input type="checkbox"/> NA
E.1.5 No visual signs of PV modules needing cleaning (e.g., dirt, bird dropping, snow)?	<input type="checkbox"/> Yes <input type="checkbox"/> No <input type="checkbox"/> NA
E.1.6 No visual signs of PV system component damage, including broken module glass, lightning strikes, or rodent damage to visible cable insulations?	<input type="checkbox"/> Yes <input type="checkbox"/> No <input type="checkbox"/> NA
E.1.7 No visual signs of PV system components showing duress, including aging, deterioration, discoloration, or corrosion.	<input type="checkbox"/> Yes <input type="checkbox"/> No <input type="checkbox"/> NA
E.1.8 Lightning protection components (where provided) are secure and in place.	<input type="checkbox"/> Yes <input type="checkbox"/> No <input type="checkbox"/> NA
E.1.9 Roof surface materials (where used) such as stone ballast and pavers are in place with the design depth.	<input type="checkbox"/> Yes <input type="checkbox"/> No <input type="checkbox"/> NA
Comments:	

Appendix F – PV maintenance contractor inspection checklist

The following is a checklist of items to consider in any annual, post-storm, or post-earthquake inspection checklist used by the PV system contractor selected to maintain the operating PV system. Provide comments for items marked “No”.

F.1 General	
F.1.1 No PV system components recalled	<input type="checkbox"/> Yes <input type="checkbox"/> No <input type="checkbox"/> NA
F.1.2 No rooftop vegetation or debris observed?	<input type="checkbox"/> Yes <input type="checkbox"/> No <input type="checkbox"/> NA
F.1.3 No shading issues have developed. Note: Shading may develop due to the growth of trees, other vegetation, or new buildings or structures. New sources of shading should be evaluated for mitigation. Mitigation may involve pruning vegetation or modifying the arrangement of PV modules (an action that should involve change management).	<input type="checkbox"/> Yes <input type="checkbox"/> No <input type="checkbox"/> NA
F.1.4 No signs of PV system component movement (e.g., movement due to high winds or seismic activity)?	<input type="checkbox"/> Yes <input type="checkbox"/> No <input type="checkbox"/> NA
F.1.5 No need to remark the PV array corners Note: Maintain marking at each array corner using a method (e.g., paint) acceptable to the roof cover manufacturer. This may help monitor the PV system for movement during future visual inspections	<input type="checkbox"/> Yes <input type="checkbox"/> No <input type="checkbox"/> NA
F.1.6 No protective layers (such as concrete pavers or gravel) have been moved to allow maintenance work and not replaced.	<input type="checkbox"/> Yes <input type="checkbox"/> No <input type="checkbox"/> NA
F.1.7 System performance is normal (report system data such as the voltage, current, power, etc., as well as the location temperature and humidity)	<input type="checkbox"/> Yes <input type="checkbox"/> No <input type="checkbox"/> NA
F.2 PV modules	
F.2.1 PV modules clean (e.g., no dirt, bird dropping, snow)?	<input type="checkbox"/> Yes <input type="checkbox"/> No <input type="checkbox"/> NA
F.2.2 PV modules do not have broken glass?	<input type="checkbox"/> Yes <input type="checkbox"/> No <input type="checkbox"/> NA
F.2.3 PV modules are not showing discoloration?	<input type="checkbox"/> Yes <input type="checkbox"/> No <input type="checkbox"/> NA
F.2.4 PV modules are securely attached to their supports?	<input type="checkbox"/> Yes <input type="checkbox"/> No <input type="checkbox"/> NA
F.3 Cables	
F.3.1 Cables are secure?	<input type="checkbox"/> Yes <input type="checkbox"/> No <input type="checkbox"/> NA
F.3.2 Cables are intact?	<input type="checkbox"/> Yes <input type="checkbox"/> No <input type="checkbox"/> NA
F.3.3 Cables show no signs of physical damage, including rodent damage.	<input type="checkbox"/> Yes <input type="checkbox"/> No <input type="checkbox"/> NA
F.3.4 Cables show no signs of corrosion?	<input type="checkbox"/> Yes <input type="checkbox"/> No <input type="checkbox"/> NA
F.3.5 Cables show no signs of discoloration or overheating.	<input type="checkbox"/> Yes <input type="checkbox"/> No <input type="checkbox"/> NA
F.3.6 Cables show no signs of contact with the roof surface.	<input type="checkbox"/> Yes <input type="checkbox"/> No <input type="checkbox"/> NA
F.4 Cable supports	

Photovoltaic (PV) systems on buildings
Design, installation, and operation

F.4.1 Cable supports are secure?	<input type="checkbox"/> Yes <input type="checkbox"/> No <input type="checkbox"/> NA
F.4.2 Cable supports are intact?	<input type="checkbox"/> Yes <input type="checkbox"/> No <input type="checkbox"/> NA
F.4.3 Cables supports are not damaging cable insulations?	<input type="checkbox"/> Yes <input type="checkbox"/> No <input type="checkbox"/> NA
F.5 Circuit connections and connectors (visible)	
F.5.1 Connections and connectors are secure?	<input type="checkbox"/> Yes <input type="checkbox"/> No <input type="checkbox"/> NA
F.5.2 Connections and connectors are intact?	<input type="checkbox"/> Yes <input type="checkbox"/> No <input type="checkbox"/> NA
F.5.3 Connections and connectors are weather-tight?	<input type="checkbox"/> Yes <input type="checkbox"/> No <input type="checkbox"/> NA
F.5.4 Connections and connectors show no signs of physical damage.	<input type="checkbox"/> Yes <input type="checkbox"/> No <input type="checkbox"/> NA
F.5.5 Connections and connectors show no signs of discoloration or overheating.	<input type="checkbox"/> Yes <input type="checkbox"/> No <input type="checkbox"/> NA
F.6 Cable trays, conduits, and cable management systems	
F.6.1 Cable trays, conduits, and cable management systems are secure?	<input type="checkbox"/> Yes <input type="checkbox"/> No <input type="checkbox"/> NA
F.6.2 Cable trays, conduits, and cable management systems are intact?	<input type="checkbox"/> Yes <input type="checkbox"/> No <input type="checkbox"/> NA
F.6.3 Cable trays, conduits, and cable management systems show no signs of corrosion.	<input type="checkbox"/> Yes <input type="checkbox"/> No <input type="checkbox"/> NA
F.6.4 Cable trays, conduits, and cable management systems are intact?	<input type="checkbox"/> Yes <input type="checkbox"/> No <input type="checkbox"/> NA
F.7 Equipment grounding	
F.7.1 Equipment grounding is secure?	<input type="checkbox"/> Yes <input type="checkbox"/> No <input type="checkbox"/> NA
F.7.2 Equipment grounding is intact?	<input type="checkbox"/> Yes <input type="checkbox"/> No <input type="checkbox"/> NA
F.7.3 Equipment grounding shows no signs of physical damage.	<input type="checkbox"/> Yes <input type="checkbox"/> No <input type="checkbox"/> NA
F.7.4 Equipment grounding shows no signs of discoloration or overheating.	<input type="checkbox"/> Yes <input type="checkbox"/> No <input type="checkbox"/> NA
F.8 Inverters	
F.8.1 Inverters are secure?	<input type="checkbox"/> Yes <input type="checkbox"/> No <input type="checkbox"/> NA
F.8.2 Inverters show no signs of physical damage.	<input type="checkbox"/> Yes <input type="checkbox"/> No <input type="checkbox"/> NA
F.8.3 Inverters show no signs of discoloration or overheating.	<input type="checkbox"/> Yes <input type="checkbox"/> No <input type="checkbox"/> NA
F.8.4 Inverters show no signs of overheating.	<input type="checkbox"/> Yes <input type="checkbox"/> No <input type="checkbox"/> NA
F.8.5 Inverter cooling fans operating?	<input type="checkbox"/> Yes <input type="checkbox"/> No <input type="checkbox"/> NA
F.9 Switches	
F.9.1 Disconnect and rapid shutdown switches are secure?	<input type="checkbox"/> Yes <input type="checkbox"/> No <input type="checkbox"/> NA
F.9.2 Disconnect and rapid shutdown switches show no signs of physical damage.	<input type="checkbox"/> Yes <input type="checkbox"/> No <input type="checkbox"/> NA
F.9.3 Disconnect and rapid shutdown switches show no signs of corrosion or discoloration.	<input type="checkbox"/> Yes <input type="checkbox"/> No <input type="checkbox"/> NA

Photovoltaic (PV) systems on buildings
Design, installation, and operation

F.10 Other PV system components	
F.10.1 Other equipment is secure?	<input type="checkbox"/> Yes <input type="checkbox"/> No <input type="checkbox"/> NA
F.10.2 Other equipment is weathertight as needed?	<input type="checkbox"/> Yes <input type="checkbox"/> No <input type="checkbox"/> NA
F.10.3 Other equipment shows no signs of physical damage?	<input type="checkbox"/> Yes <input type="checkbox"/> No <input type="checkbox"/> NA
F.10.4 Other equipment shows no signs of corrosion?	<input type="checkbox"/> Yes <input type="checkbox"/> No <input type="checkbox"/> NA
F.11 Signage	
F.11.1 Signs are in place?	<input type="checkbox"/> Yes <input type="checkbox"/> No <input type="checkbox"/> NA
F.11.2 Signs are legible?	<input type="checkbox"/> Yes <input type="checkbox"/> No <input type="checkbox"/> NA
F.12 Points where the PV system penetrates the building	
F.12.1 Firestopping is intact	<input type="checkbox"/> Yes <input type="checkbox"/> No <input type="checkbox"/> NA
Comments:	

Appendix G - PV maintenance contactor testing and maintenance checklist

The following is a checklist of annual testing and periodic maintenance items for the PV system contractor to consider as they maintain the operating PV system. Provide comments for items marked “No”.

G.1 Annual testing	
G.1.1 Electrical infrared testing completed for electrical enclosures? Note: Electrical infrared testing evaluates electrical components and wiring connections to identify loose electrical connections and failing components.	<input type="checkbox"/> Yes <input type="checkbox"/> No <input type="checkbox"/> NA
G.1.2 No electrical infrared testing issues identified?	<input type="checkbox"/> Yes <input type="checkbox"/> No <input type="checkbox"/> NA
G.1.3 PV array infrared testing completed for the PV modules and PV arrays? Note: PV array infrared testing evaluates PV modules to identify temperature anomalies, such as hot module junction boxes or hot cells within a module. Notes hot spots will need further investigation to determine if an actual concern is present.	<input type="checkbox"/> Yes <input type="checkbox"/> No <input type="checkbox"/> NA
G.1.4 No PV array infrared testing issues identified?	<input type="checkbox"/> Yes <input type="checkbox"/> No <input type="checkbox"/> NA
G.1.5 DC disconnect switches have been operated ten times? Note: This activity is intended to mechanically wipe corrosion from internal switch contacts/)	<input type="checkbox"/> Yes <input type="checkbox"/> No <input type="checkbox"/> NA
G.1.6 Rapid shutdown switches have been tested to verify their function.	<input type="checkbox"/> Yes <input type="checkbox"/> No <input type="checkbox"/> NA
G.1.7 Arc fault and ground fault devices setpoint have been calibrated?	<input type="checkbox"/> Yes <input type="checkbox"/> No <input type="checkbox"/> NA
G.1.8 Arc fault and ground fault devices setpoint have been tested?	<input type="checkbox"/> Yes <input type="checkbox"/> No <input type="checkbox"/> NA
G.1.9 PV system surge protection devices are functional?	<input type="checkbox"/> Yes <input type="checkbox"/> No <input type="checkbox"/> NA
G.1.10 Remote fault monitoring is provided for the PV system.	<input type="checkbox"/> Yes <input type="checkbox"/> No <input type="checkbox"/> NA
G.1.11 Have ground, arc, inverter, and any other faults detected by the PV system been tested to verify appropriate actions (automatic shutdown) and signaling to the remote monitoring points?	<input type="checkbox"/> Yes <input type="checkbox"/> No <input type="checkbox"/> NA
G.2 Periodic maintenance	
G.2.1 Troubleshooting is provided when arc, ground, or inverter faults are detected.	<input type="checkbox"/> Yes <input type="checkbox"/> No <input type="checkbox"/> NA
G.2.2 PV module replacement is performed as needed due to aging or damage. Note: Damage may be due to hailstorms, sandstorms, or movement associated with earthquakes or wind. If the modules can be replaced with the same make and model, complete the maintenance and document the action taken. If the same PV module make and model is unavailable, follow the change management process to verify an acceptable replacement. Disconnect the involved PV modules until the replacement PV modules are installed.	<input type="checkbox"/> Yes <input type="checkbox"/> No <input type="checkbox"/> NA

Photovoltaic (PV) systems on buildings
Design, installation, and operation

<p>G.2.3 PV systems are serviced as needed when PV system components have moved (e.g., due to wind or seismic activity).</p> <p>Note: PV system movement may apply stress to PV modules, junction boxes, combiner boxes, PV system cables, or other system components. The maintenance objective is to relieve any stresses, restore the components to their original location, identify any components that need to be replaced, restore the system, and test the system.</p>	<p><input type="checkbox"/> Yes <input type="checkbox"/> No <input type="checkbox"/> NA</p>
<p>G.2.4 Roof protective layers (such as concrete pavers or gravel) that have been moved are restored to their original position.</p> <p>Note: Protective layers such as concrete pavers or gravel may be needed to help minimize the PV system fire hazard to the building. They need to be placed back in their original position once maintenance work is complete.</p>	<p><input type="checkbox"/> Yes <input type="checkbox"/> No <input type="checkbox"/> NA</p>
<p>G.2.5 PV module shading issues are corrected?</p> <p>Note: Shading may develop due to the growth of trees, other vegetation, or new buildings or structures. New sources of shading should be evaluated for mitigation. Mitigation may involve pruning vegetation or modifying the arrangement of PV modules (an action that should involve change management).</p>	<p><input type="checkbox"/> Yes <input checked="" type="checkbox"/> No <input type="checkbox"/> NA</p>
<p>G.2.6 Cable connections checked for torque at all terminations?</p>	<p><input type="checkbox"/> Yes <input type="checkbox"/> No <input type="checkbox"/> NA</p>
<p>G.2.7 Electrical enclosures cleaned internally?</p>	<p><input type="checkbox"/> Yes <input type="checkbox"/> No <input type="checkbox"/> NA</p>
<p>G.2.8 Inverter filters are clean or replaced as needed?</p>	<p><input type="checkbox"/> Yes <input type="checkbox"/> No <input type="checkbox"/> NA</p>
<p>Comments:</p>	

Appendix H – PV system plan submittal checklists

The following checklist outlines the information to include as part of a document set submitted to Zurich for review and comment.

H.1 Photovoltaic system design documents	
<p>Include the following information as part of a document set submitted to Zurich for review and comment or to be shared with a third-party quality assurance person for use during their review of a new or existing PV system.</p> <p>In addition, the as-built information in this checklist should be maintained for use by the:</p> <ul style="list-style-type: none"> • PV system and building owner. • PV system maintainer. • Public fire service (for pre-fire planning and emergency response). 	
H.1.1 Contact information – Designer, developer, engineer, building owner.	<input type="checkbox"/> Yes <input type="checkbox"/> No <input type="checkbox"/> NA
H.1.2 Site plan – Diagram of the building, site, and adjacent roads to locate and identify the project.	<input type="checkbox"/> Yes <input type="checkbox"/> No <input type="checkbox"/> NA
H.1.3 Scope of work – Location address and specific roof areas(s) involved.	<input type="checkbox"/> Yes <input type="checkbox"/> No <input type="checkbox"/> NA
H.1.4 Array layout – Diagram of roof area occupied by the PV system components as well as unoccupied roof areas including roof edge setbacks (size and location), walkways (size and location), rooftop obstructions (e.g., expansion joints, seismic joints, roof drains, vent pipes, gas lines, HVAC, satellite dishes, skylights, and other rooftop features).	<input type="checkbox"/> Yes <input type="checkbox"/> No <input type="checkbox"/> NA
H.1.5 Fire service access plan.	<input type="checkbox"/> Yes <input type="checkbox"/> No <input type="checkbox"/> NA
H.1.6 Bill of materials – Make, model, and number of all system components.	<input type="checkbox"/> Yes <input type="checkbox"/> No <input type="checkbox"/> NA
H.1.7 Product literature – PV modules including: <ul style="list-style-type: none"> • Test laboratories listing the product. • Make and type of connectors. • Hail rating of the selected product. 	<input type="checkbox"/> Yes <input type="checkbox"/> No <input type="checkbox"/> NA
H.1.8 Product literature – Dc-to-dc converters including: <ul style="list-style-type: none"> • Test laboratories listing the product. • Make and type of connectors. 	<input type="checkbox"/> Yes <input type="checkbox"/> No <input type="checkbox"/> NA
H.1.9 Product literature – Inverters including: <ul style="list-style-type: none"> • Test laboratories listing the product. • Ability to support remote monitoring for inverter, arc, and ground faults. 	<input type="checkbox"/> Yes <input type="checkbox"/> No <input type="checkbox"/> NA
H.1.10 Product literature – PV module racking including: <ul style="list-style-type: none"> • Any test laboratory listing the product. 	<input type="checkbox"/> Yes <input type="checkbox"/> No <input type="checkbox"/> NA
H.1.11 Electrical notes including: <ul style="list-style-type: none"> • Codes and standards (applicable to the project). 	<input type="checkbox"/> Yes <input type="checkbox"/> No <input type="checkbox"/> NA

Photovoltaic (PV) systems on buildings
Design, installation, and operation

<ul style="list-style-type: none"> • Conductor, cable tray, and conduit specifications. • List if diagram symbols. 	
H.1.12 General notes	<input type="checkbox"/> Yes <input type="checkbox"/> No <input type="checkbox"/> NA
<p>H.1.13 Electrical plans including:</p> <ul style="list-style-type: none"> • Location and routing of cables and equipment. • String diagrams including module level power electronics (where applied). • Cable protection from physical injury and UV light (cable placed under PV modules, in conduits, or in other coverings). • Cable arrangement to avoid contact with grounded metal parts. • Cable arrangement to separate dc cables of different polarity when not in a conduit, cable tray, or other enclosure. • Single line diagrams. • Bonding and grounding details. • Support and securement of conduits, cable trays, and inverter racks. • Rapid shutdown notes and information (where provided). 	<input type="checkbox"/> Yes <input type="checkbox"/> No <input type="checkbox"/> NA
H.1.13 Signage	<input type="checkbox"/> Yes <input type="checkbox"/> No <input type="checkbox"/> NA
<p>H.1.14 PV module racking drawings including:</p> <ul style="list-style-type: none"> • Module securement. • Rack elements. • Rack securement against wind and earthquake loads (ballast and mechanical securement). 	<input type="checkbox"/> Yes <input type="checkbox"/> No <input type="checkbox"/> NA

H.2 Structural engineering report	
<p>H.2.1 Structural loads.</p> <p>Note: Calculations to verify the added PV system loads can be supported by the building including snow loads, where exposed.</p>	<input type="checkbox"/> Yes <input type="checkbox"/> No <input type="checkbox"/> NA
<p>H.2.2 Structural upgrades.</p> <p>Note: Calculations to verify the added PV system loads can be supported by the building along with recommended structural upgrades, if any.</p>	<input type="checkbox"/> Yes <input type="checkbox"/> No <input type="checkbox"/> NA
<p>H.2.3 Wind loads</p> <p>Note: Calculations to verify each connection in the load path from the PV module to the building structure or ballast will withstand the calculated wind uplift loads or loads established by wind tunnel testing. The calculations are to be based on the Zurich recommended minimum design wind speed design or higher.</p>	<input type="checkbox"/> Yes <input type="checkbox"/> No <input type="checkbox"/> NA
<p>H.2.4 Earthquake loads</p> <p>Note: Calculations to verify the PV system will be secured against anticipated horizontal and vertical earthquake loads, where exposed.</p>	<input type="checkbox"/> Yes <input type="checkbox"/> No <input type="checkbox"/> NA

Photovoltaic (PV) systems on buildings
Design, installation, and operation

H.3 Automatic fire alarm system	
This is for the rooftop PV system fire detection system.	
H.3.1 Bill of materials.	<input type="checkbox"/> Yes <input type="checkbox"/> No <input type="checkbox"/> NA
H.3.2 Manufacturer's literature on each component including: <ul style="list-style-type: none"> • Model number. • Selected options. • Internal wiring diagram. • Product approvals, certifications, and listings. 	<input type="checkbox"/> Yes <input type="checkbox"/> No <input type="checkbox"/> NA
H.3.3 Point-to-point wiring diagram showing the interconnection of each system component.	<input type="checkbox"/> Yes <input type="checkbox"/> No <input type="checkbox"/> NA
H.3.4 Placement drawing showing the physical location of each system component.	<input type="checkbox"/> Yes <input type="checkbox"/> No <input type="checkbox"/> NA
H.3.5 Description of wiring methods. Specifically, the type of wire used and the arrangement of physical protection where needed.	<input type="checkbox"/> Yes <input type="checkbox"/> No <input type="checkbox"/> NA
H.3.6 Description of the electrical supervision of system wiring.	<input type="checkbox"/> Yes <input type="checkbox"/> No <input type="checkbox"/> NA
H.3.7 Description of the on primary and secondary power supplies.	<input type="checkbox"/> Yes <input type="checkbox"/> No <input type="checkbox"/> NA
H.3.8 Back-up battery calculations.	<input type="checkbox"/> Yes <input type="checkbox"/> No <input type="checkbox"/> NA

H.4 Automatic deluge water spray system	
This relates to the rooftop PV systems installed on roofs with polystyrene insulation	
H.4.1 All data required by the applicable Zurich Recognized Protection Principle (e.g., EN, NFPA, or VdS).	<input type="checkbox"/> Yes <input type="checkbox"/> No <input type="checkbox"/> NA
H.4.2 Piping drawings including: <ul style="list-style-type: none"> • Pipe • Fittings • Valves • Nozzles 	<input type="checkbox"/> Yes <input type="checkbox"/> No <input type="checkbox"/> NA
H.4.3 Manufacturer's literature for all system components that includes: <ul style="list-style-type: none"> • Verification of product approvals, certifications, and listings. • Outline of special listing requirements (e.g., flow and pressure requirements for the selected nozzles). • Friction loss data (e.g., for pipe, backflow preventers, meters, etc.). 	<input type="checkbox"/> Yes <input type="checkbox"/> No <input type="checkbox"/> NA
H.4.4 Hydraulic calculations	<input type="checkbox"/> Yes <input type="checkbox"/> No <input type="checkbox"/> NA
H.4.5 Water supply information including the source, the source volume, and a flow test with date and location.	<input type="checkbox"/> Yes <input type="checkbox"/> No <input type="checkbox"/> NA
H.4.6 Earthquake bracing calculations for installations located in identified seismic zones.	<input type="checkbox"/> Yes <input type="checkbox"/> No <input type="checkbox"/> NA

Photovoltaic (PV) systems on buildings
Design, installation, and operation

H.5 Lightning protection	
This relates to rooftop PV system installed in areas where lightning rates High or Very High as determined by Zurich.	
H.5.1 Bill of materials.	<input type="checkbox"/> Yes <input type="checkbox"/> No <input type="checkbox"/> NA
H.5.2 Manufacturer's literature on each component including model number; selected options; and product approvals, certifications, and listings.	<input type="checkbox"/> Yes <input type="checkbox"/> No <input type="checkbox"/> NA
H.5.3 Placement drawing showing the physical location of each system component.	<input type="checkbox"/> Yes <input type="checkbox"/> No <input type="checkbox"/> NA
H.5.4 Drawings showing attachments and securement for air terminals, masts, conductors, etc.	<input type="checkbox"/> Yes <input type="checkbox"/> No <input type="checkbox"/> NA
H.5.5 Point-to-point wiring diagram showing the interconnection of each system component including air terminals, masts, conductors, bonding conductors, and ground electrodes.	<input type="checkbox"/> Yes <input type="checkbox"/> No <input type="checkbox"/> NA
H.5.6 Drawings confirming the zones of protection.	<input type="checkbox"/> Yes <input type="checkbox"/> No <input type="checkbox"/> NA

The Zurich Services Corporation
Zurich Resilience Solutions | Risk Engineering
1299 Zurich Way, Schaumburg, IL 60196-056
800.982.5964 www.zurichna.com

This is a general description of (insurance) services such as risk engineering or risk management services by Zurich Resilience Solutions which is part of the Commercial Insurance business of Zurich Insurance Group, and does not represent or alter any insurance policy or service agreement. Such (insurance) services are provided to qualified customers by affiliated companies of Zurich Insurance Company Ltd, including but not limited to Zurich American Insurance Company, 1299 Zurich Way, Schaumburg, IL 60196, USA, The Zurich Services Corporation, 1299 Zurich Way, Schaumburg, IL 60196, USA, Zurich Insurance plc, Zurich House, Ballsbridge Park, Dublin 4, Ireland, Zurich Commercial Services (Europe) GmbH, Platz der Einheit, 2, 60327 Germany, Zurich Management Services Limited, The Zurich Centre, 3000b Parkway, Whiteley, Fareham, Hampshire, PO15 7JZ, UK, Zurich Insurance Company Ltd, Mythenquai 2, 8002 Zurich, Switzerland, Zurich Australian Insurance Limited, ABN 13 000 296 640, Australia.

The opinions expressed herein are those of Zurich Resilience Solutions as of the date of the release and are subject to change without notice. This document has been produced solely for informational purposes. All information contained in this document has been compiled and obtained from sources believed to be reliable and credible but no representation or warranty, express or implied, is made by Zurich Insurance Company Ltd or any of its affiliated companies (Zurich Insurance Group) as to their accuracy or completeness. This document is not intended to be legal, underwriting, financial, investment or any other type of professional advice. Zurich Insurance Group disclaims any and all liability whatsoever resulting from the use of or reliance upon this document. Nothing express or implied in this document is intended to create legal relations between the reader and any member of Zurich Insurance Group.

Certain statements in this document are forward-looking statements, including, but not limited to, statements that are predictions of or indicate future events, trends, plans, developments or objectives. Undue reliance should not be placed on such statements because, by their nature, they are subject to known and unknown risks and uncertainties and can be affected by numerous unforeseeable factors. The subject matter of this document is also not tied to any specific service offering or an insurance product nor will it ensure coverage under any insurance policy.

This document may not be distributed or reproduced either in whole, or in part, without prior written permission of Zurich Insurance Company Ltd, Mythenquai 2, 8002 Zurich, Switzerland. No member of Zurich Insurance Group accept any liability for any loss arising from the use or distribution of this document. This document does not constitute an offer or an invitation for the sale or purchase of securities in any jurisdiction.

In the United States, Risk Engineering services are provided by The Zurich Services Corporation.
Zurich Resilience Solutions

©2024 The Zurich Services Corporation. All rights reserved.

